

BM6x Antenna information

Preface:

This document describes the PCB antenna design for the BM6x BLUETOOTH module.

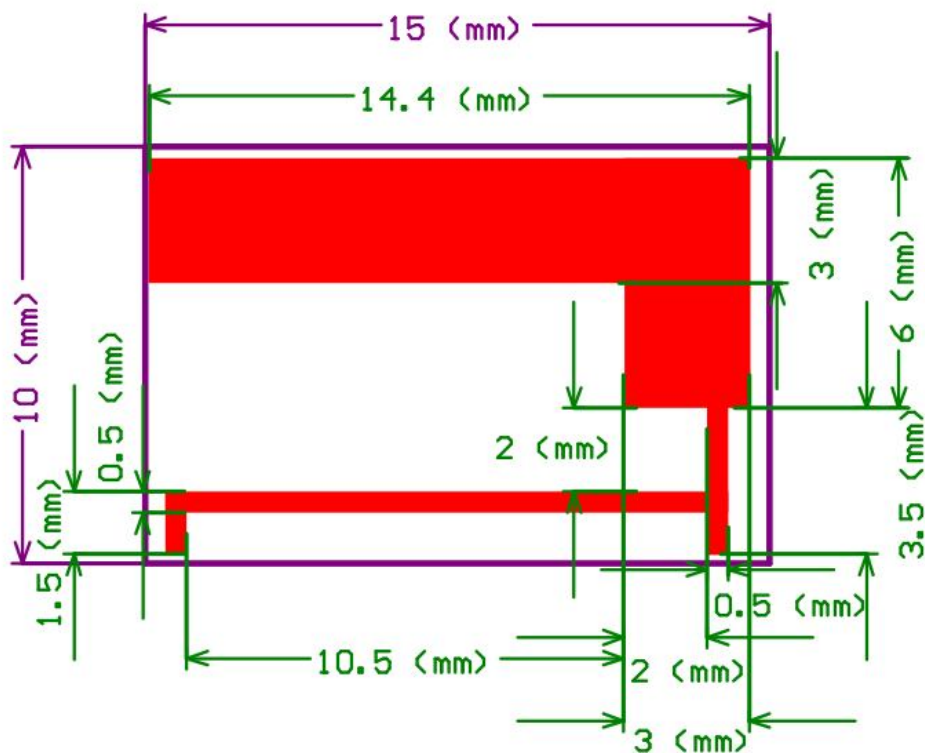
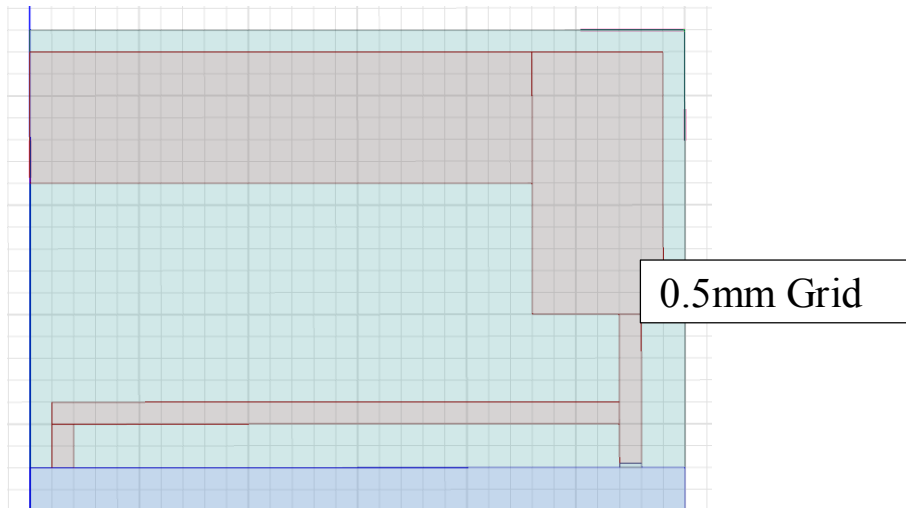
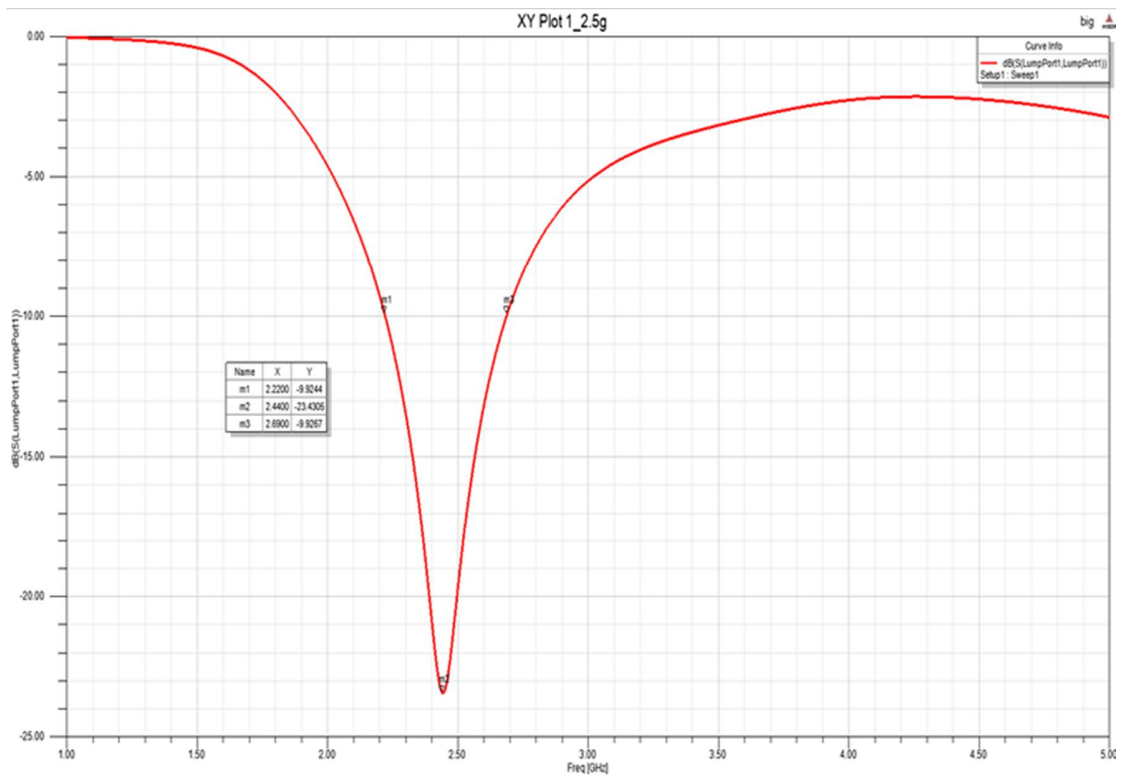
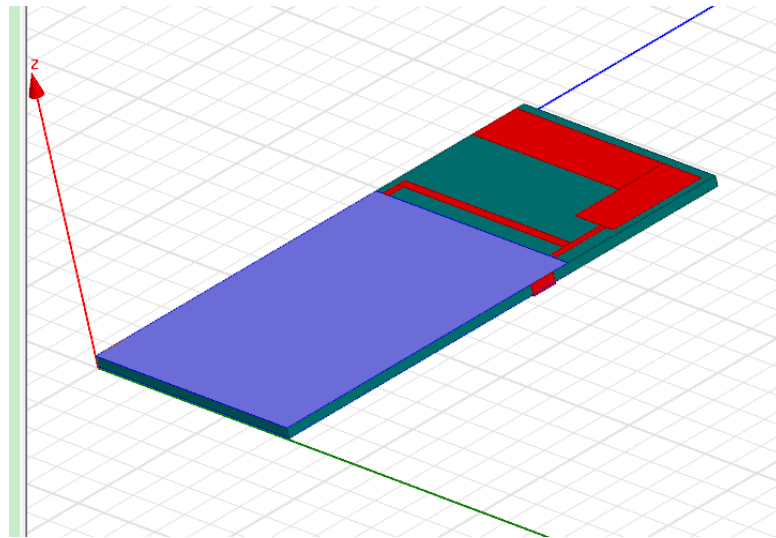

Simulation of the PCB antenna:



The S22 simulation result, the bandwidth of this PCB antenna design could be up to 500MHz

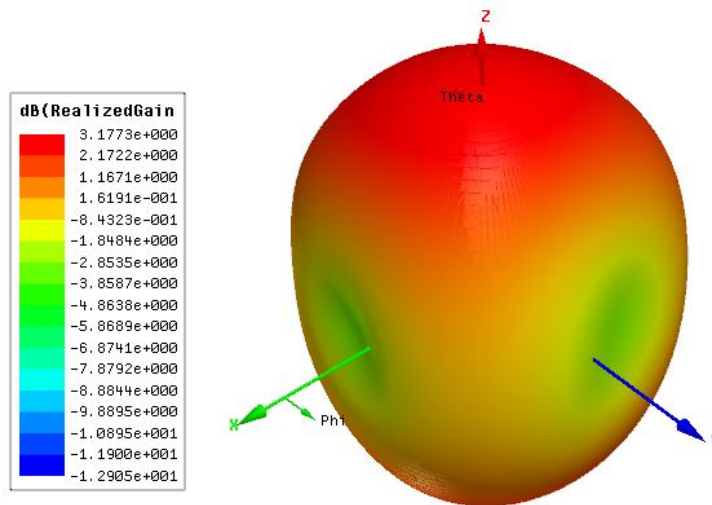

Simulation of the radiation pattern

Simulation result review:

- From the simulation result, the antenna resonates could cover BLUETOOTH spec, and bandwidth is good enough.
- The antenna has been verified in simulation and also fine tuning on the actual module PCB
- The simulation result is based on a substrate thickness of 0.6mm (module) and mother board is 1.6 mm.
- If the mother board size has any deviation, the result in significant antenna performance difference

Real Measurement

1. 3D Radiation pattern based on DUT

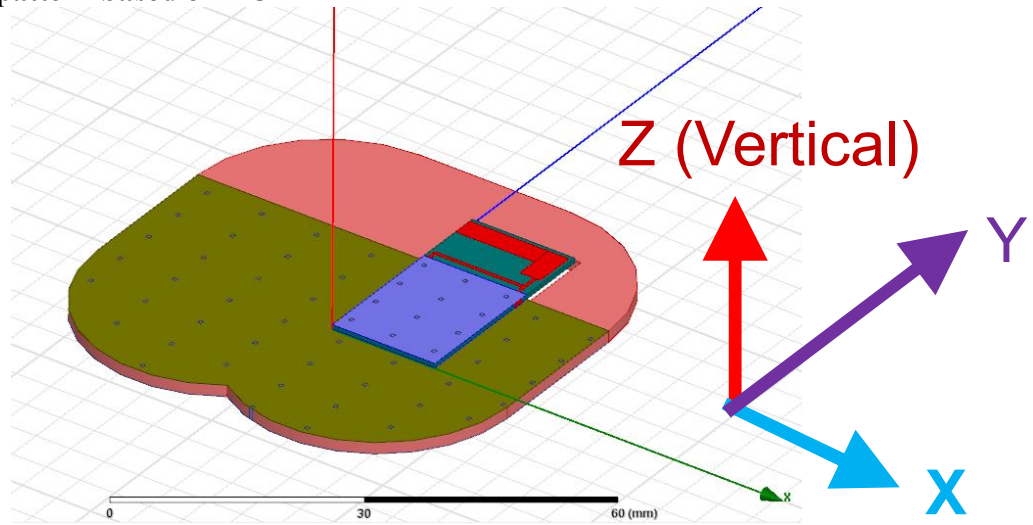

S22 measurement

The measurement result: the bandwidth of the antenna could be up to 800MHz, and could cover BLUETOOTH spec

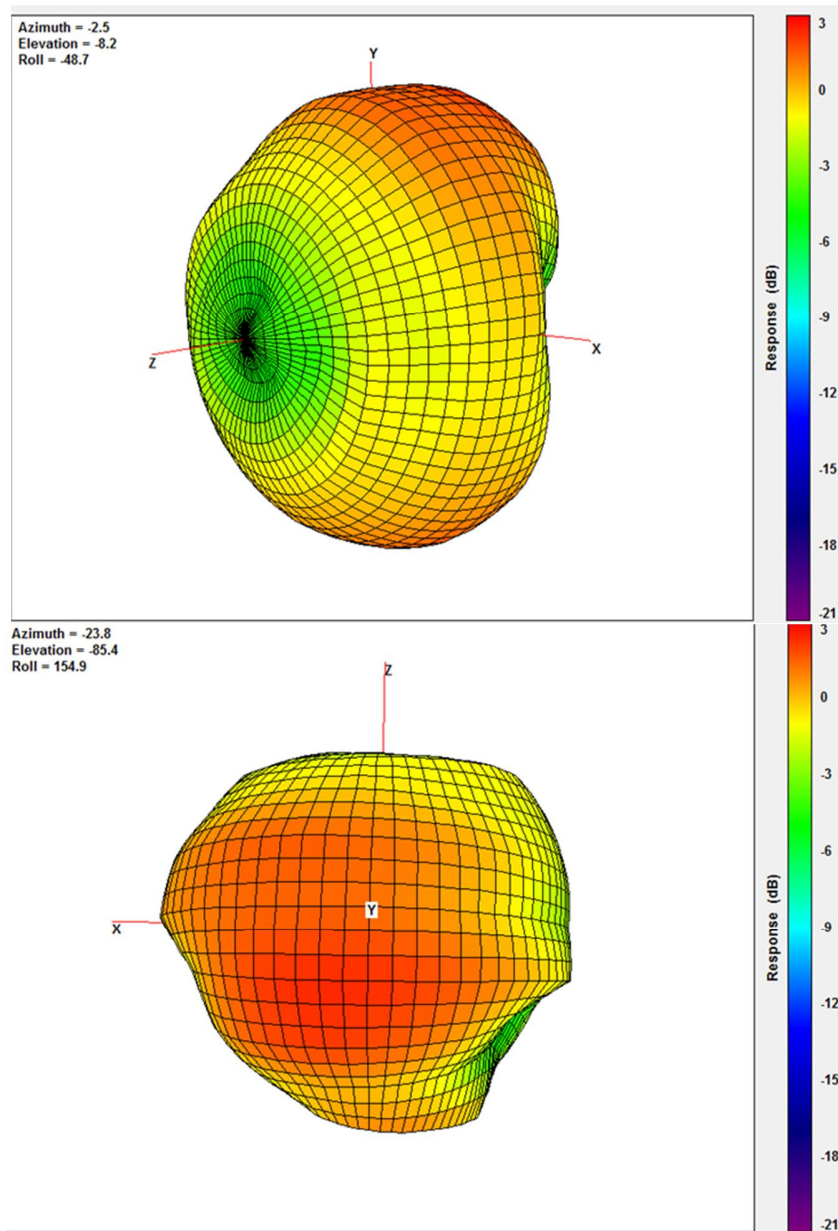

3D pattern scan in antenna lab, out-sourcing

Frequency (MHz)	2400	2440	2480
Ant. Port Input Pwr. (dBm)	0	0	0
Tot. Rad. Pwr. (dBm)	-1.342	-1.189	-1.244
Efficiency (%)	73.41	76.05	75.09
Gain (dBi)	1.927	1.904	1.781

The antenna efficiency could be up to 75%, with antenna gain 1.927dBi