

东莞市创芯微电子科技有限公司
Dongguan Chuangxin Microelectronics
Technology Co., Ltd

承认书

SPECIFICATION FOR APPROVAL

客户名称

CUSTOMER NAME: 世威

产品名称

PRODUCT NAME: 2.4G Onboard antenna

客户料号

CUSTOMER P/N: R1319A

	供应商 supplier	客户 customer
制作 CHECKED BY:	张鸿达	
审核 APPROVED BY:	彭军法	
日期 DATE:	2024/4/23	

1.规格表 Specification Table

产品主要技术参数

Main technical specifications of the product

频率范围 (Mhz) Frequency Range	2400-2500
特性阻抗 (Ω) Characteristic Impedance	50
增益 (dBi) Avg Gain	-1.41
输出电压驻波比 Output voltage standing wave ratio (VSWR)	≤ 3.8
极化方式 Polarization mode	线极化 Linear

2.尺寸图 size

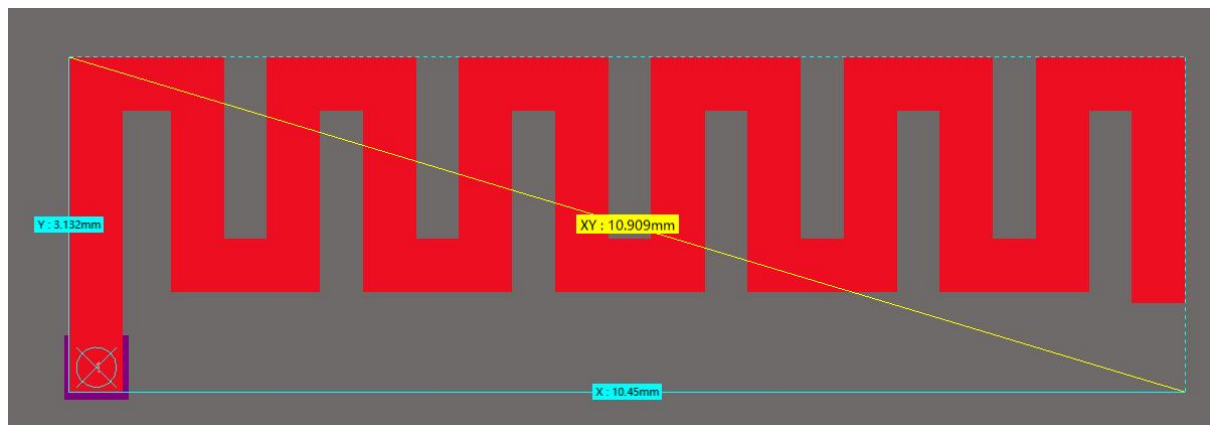

尺寸: 3.132mm*10.45mm

3.测试报告 test report (Only for prototype testing report)

3.1: 网络分析仪测试报告 Network analyzer report



3.2: 暗室 2D、3D 整机数据 Dark room 2D and 3D machine data

3.2.1 效率及增益 Efficiency and gain

Frequency (MHz)	2400	2450	2500
Avg. Gain (dBi)	-1.32	-1.03	-1.9
Peak Gain (dBi)	0.8	1.0	0.1
Efficiency (%)	37.72	40.4	28

3.2.2 有源测试报告 Active test report

耳机 headset				
	头模 headform		自由 free	
channel	TRP	TIS	TRP	TIS
0	2.13	-89.12	3.86	-91.24
39	3.68	-89.92	4.23	-91.47
78	0.98	-86.18	1.06	-86.80

3.2.3 匹配电路 Matching circuit

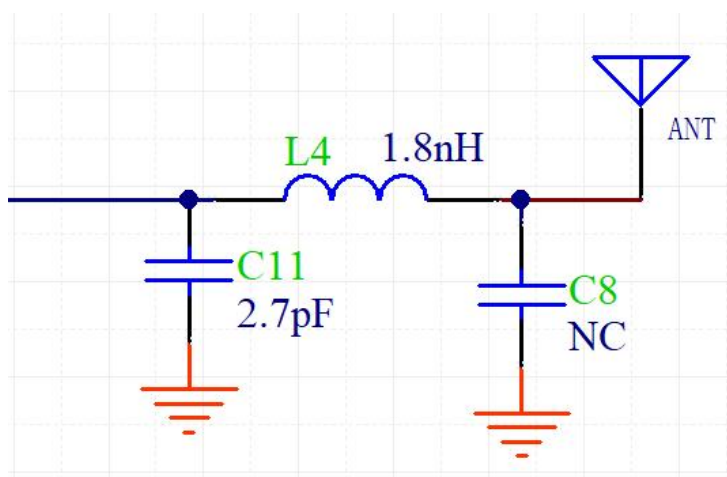

3.2.4 2D/3D 场型图 Field pattern diagram

