

Shenzhen Hetuo Technology Co., Ltd

Building 1202B, Building C 6, Hengfeng industrial city, Hezhou, xixiang, Baoan District, Shenzhen City

Sample Approved Sheet

Antenna Type: FPC Antenna

Hetuo (R1328-R) Acknowledgment

Customer Name Dongguan Shui Wo Electronic Technology Co. , Ltd.

Client Type R1328

Brand HT-R1328-R

Hetuo Judgment Audit Team

Formulate	Check	Ratify	Acknowledge the book completion time
Liyaona	Huxuewen	Daitingting	2024.9.14

(Ruihe) Judgment Audit Team

Acknowledgement Number _____

Proving time

acknowledge	check	ratify	Acknowledge the book completion time

Project Review Three acknowledgements Specifications/drawings

examining report Specimen PCS Safety standard HSF

Appraisal report Accept

Conditional acceptance

Refuse

Confidential Information

Items	Date	Version	The revised notes	Notes
1	2024. 9. 14	A0	For the first time	
2				

1. Antenna picture

The report mainly provides the test status of the electrical properties parameters of **HT-R1328 -R**.
The **HT-R1328 -R** antenna is a **BT** Band . The antenna Picture and assembly are shown below.



Antenna picture & assembly picture

2. Antenna Test Equipment Introduction

Test of antenna input characteristics using Agilent E5071C and Agilent 5062A vector network analyzer; The radiation pattern of the antenna are tested using the Satimo starlab 3D near field Anechoic Chamber , and the instrument is used to agilent8960 E5515 and Agilent E4438C. The test coordinates of the darkroom are as follows:



图4 3D微波暗室测试坐标系 (back view)

Coordinate system for 3D microwave darkroom testing

3. Electrical Specification

3-2 Passive S11 parameter

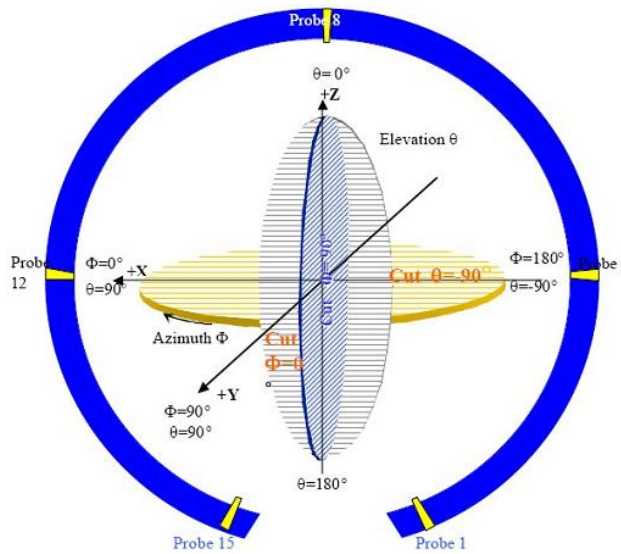
Measuring Method is a 50Ω coaxial cable is connected to the antenna. Then this cable is connected to a network analyzer to measure the S11 parameter, Keeping this fixture away from metal at least 20cm.

VSWR

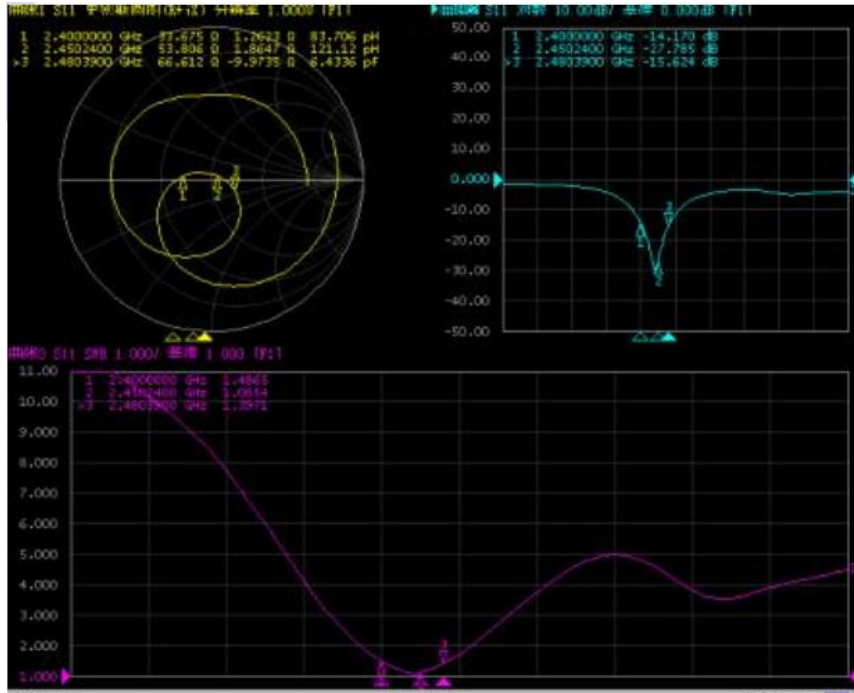

3-3 Antenna Matching Network

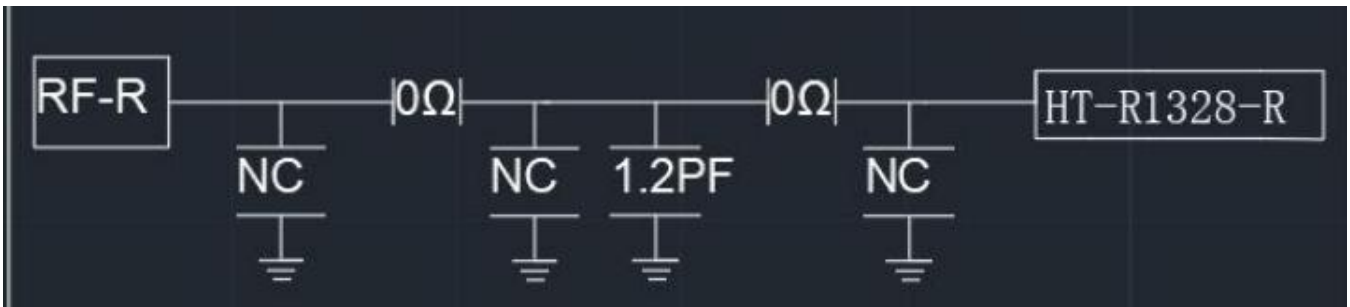

Frequency ID	1	2	3	4	5	6	7	8	9	10	11
Frequency (MHz)	2400.0	2410.0	2420.0	2430.0	2440.0	2450.0	2460.0	2470.0	2480.0	2490.0	2500.0
Efficiency (dBi)	-5.60	-5.38	-5.28	-5.09	-5.07	-4.91	-5.00	-4.83	-4.94	-5.10	-5.20
Gain (dBi)	-2.29	-1.94	-1.76	-1.92	-1.58	-1.23	-1.15	-0.53	-0.68	-1.22	-1.13
Efficiency (%)	27.57	28.94	29.63	30.95	31.11	32.31	31.62	32.91	32.03	30.91	30.23
Directivity (dB)	3.31	3.44	3.53	3.17	3.49	3.67	3.85	4.30	4.26	3.88	4.06
Peak Gain Position (Theta)	135.00	90.00	135.00	120.00	90.00	0.00	90.00	90.00	90.00	90.00	90.00
Peak Gain Position (Phi)	120.00	0.00	135.00	15.00	135.00	30.00	15.00	15.00	15.00	15.00	15.00
Efficiency ThetaPol (%)	10.01	10.47	10.77	11.35	11.49	12.20	12.51	13.83	14.35	14.40	14.58
Efficiency PhiPol (%)	17.56	18.47	18.86	19.59	19.62	20.10	19.10	19.07	17.67	16.51	15.66
Upper Hem. Efficiency (%)	14.91	15.46	15.90	16.48	16.80	17.46	17.58	18.39	18.06	17.22	16.67
Lower Hem. Efficiency (%)	12.66	13.48	13.73	14.47	14.32	14.84	14.03	14.52	13.97	13.69	13.57

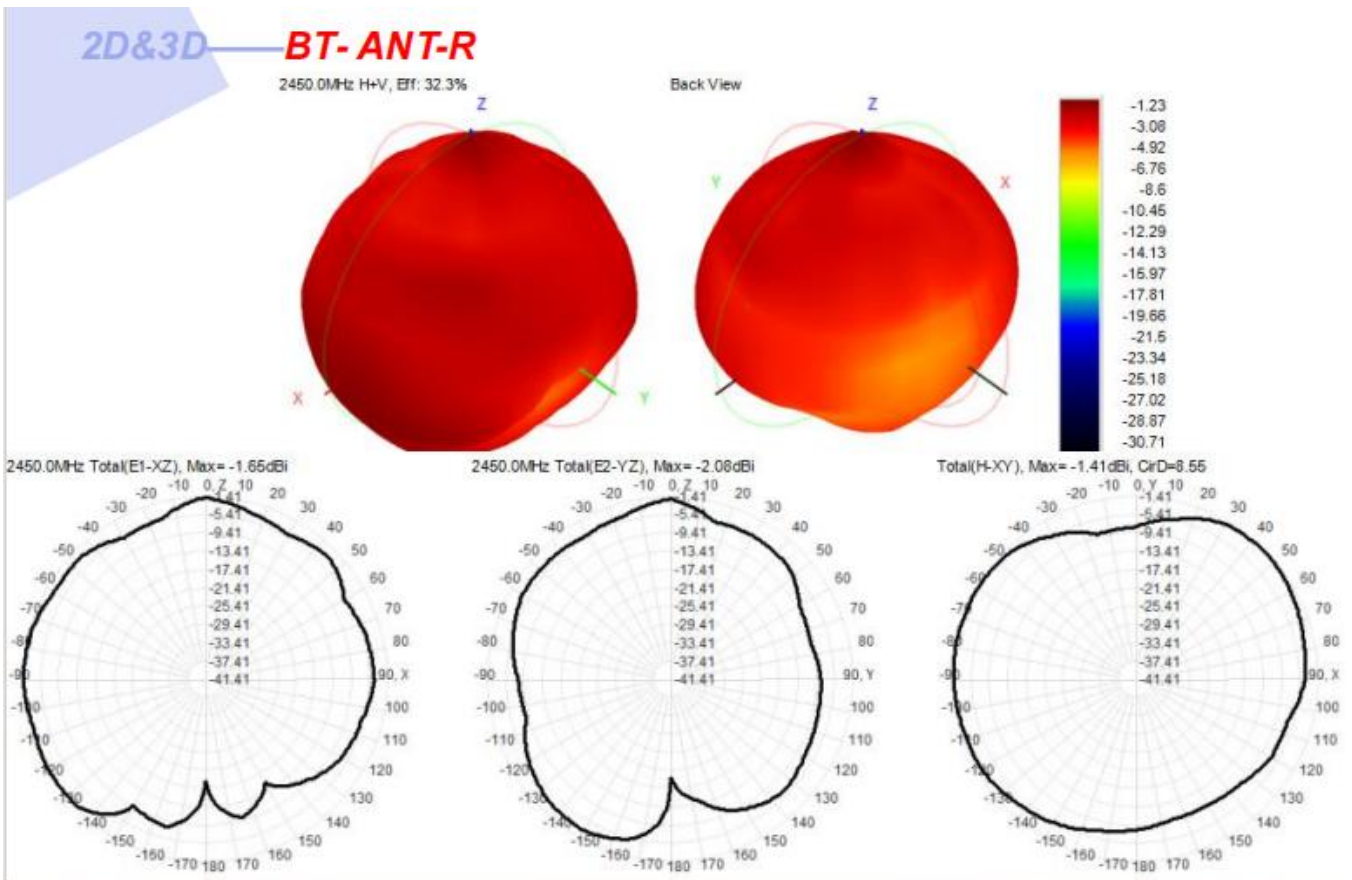
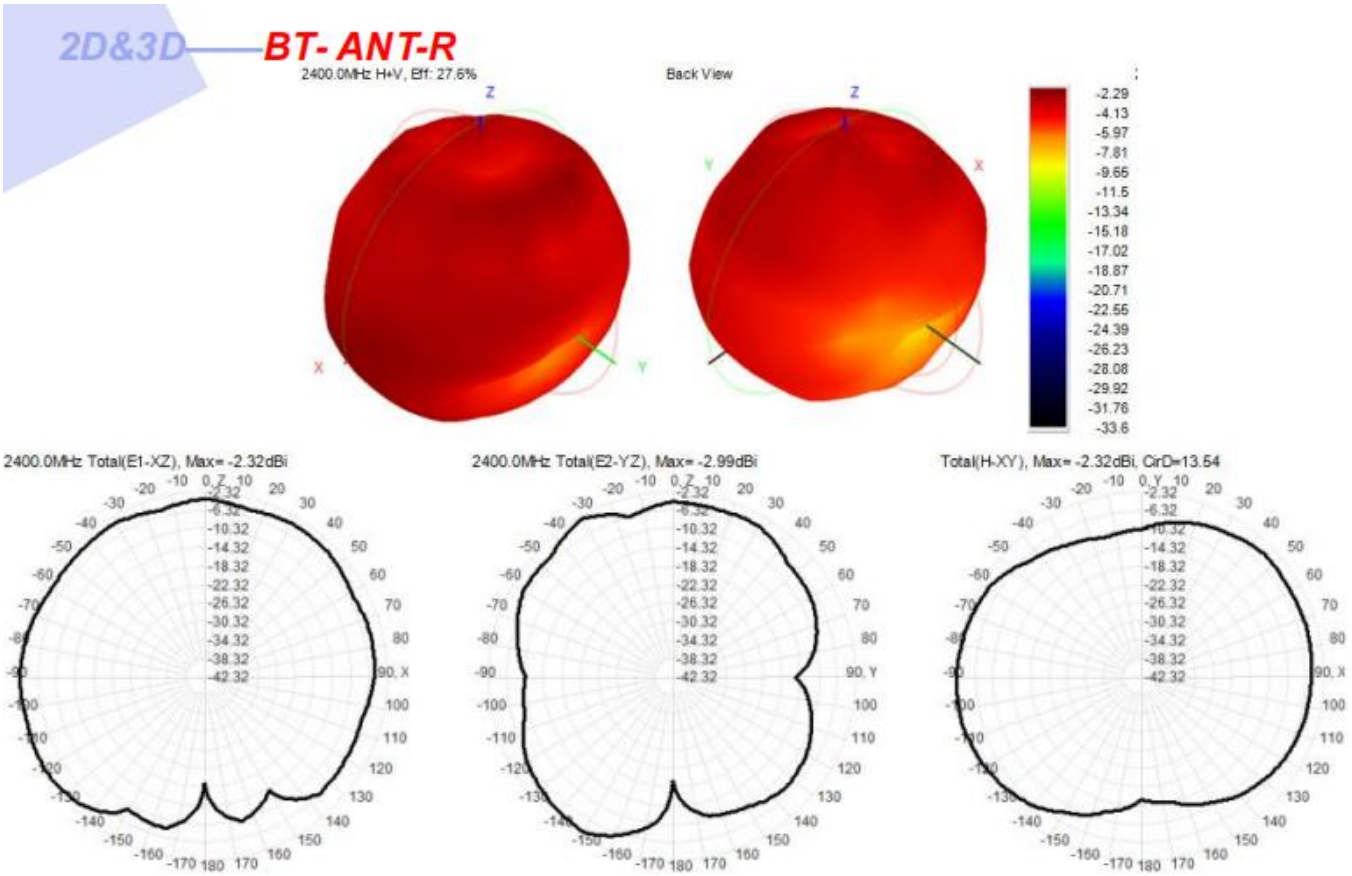

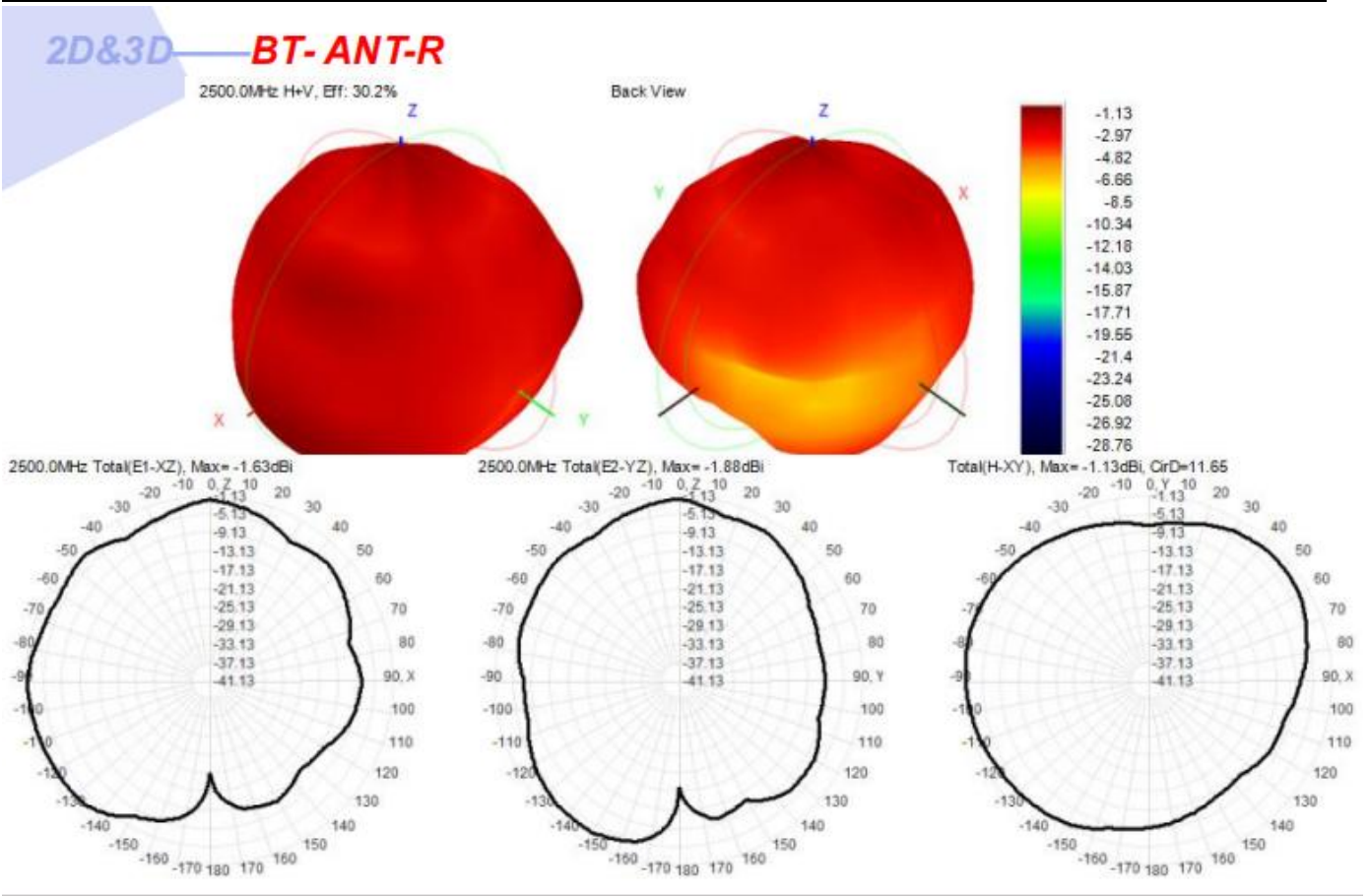

OTA DATA(R)--自由空间1#

Test Equipment:	R&S CMW500			
Test Condition:				
Band	Wireless Protocol	Channel	TRP(dBm)	TIS(dBm)
BT		0	3.23	-87.94
		39	3.85	-87.65
		78	3.15	-87.35

OTA DATA(R)--头模

Test Equipment:	R&S CMW500			
Test Condition:				
Band	Wireless Protocol	Channel	TRP(dBm)	TIS(dBm)
BT		0	1.21	-84.45
		39	1.43	-84.64
		78	1.54	-84.28

4. Mechanical Specification:

Mechanical Configuration (Unit: mm)

The appearance of the antenna is according to drawing Figure 8

MODIFICATION	
NO.	DATE
DESCRIPTION	BY / CHECKED
	217.00

Adhesive backing area

背胶面区域

背胶纸切断线位

Cutting line position of adhesive paper

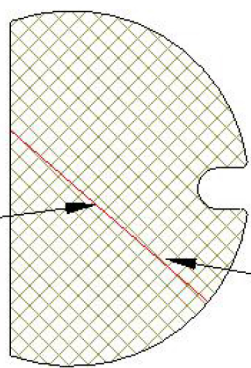
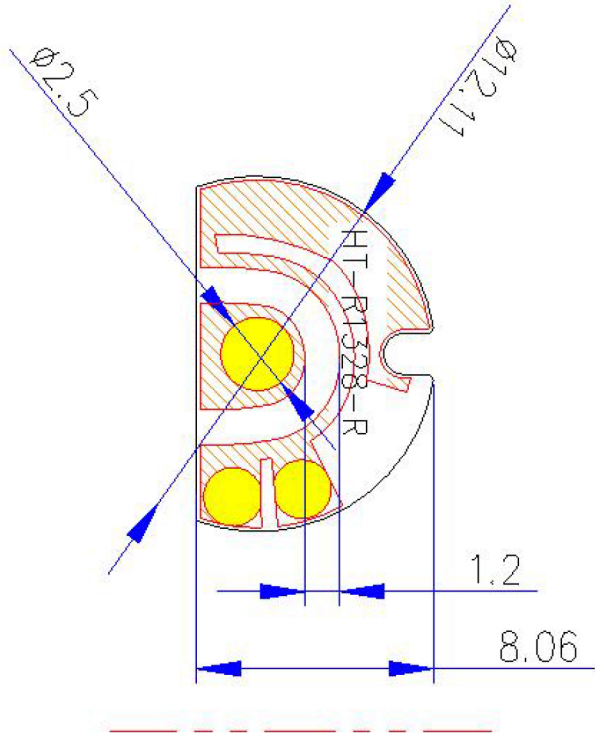

PART NUMBER		REV		DATE		BY		CHK	
HT-R1328-R	1.1								
<p>THIS NUMBER AND ASSOCIATION OF THE PART OF ADHESIVE BACKING IS FOR IDENTIFICATION PURPOSES ONLY AND SHALL NOT BE PRESENTED IN FORM AS THE INDICATED IN THE DRAWING.</p>									
<p>UNIT: MILLIMETER</p>									
<p>SCALE: 1:1</p>									
<p>PROJECT NO.: HT-20220620001-R1328</p>									
<p>DATE: 2022.06.10</p>									
<p>SHEET: 1 OF 1</p>									