

**IEEE 802.11 a/b/g/n/ac/ax 2T/2R+ Bluetooth V2.1/4.2/5.2
USB2.0/3.0 Module**

Model Number:WXT28M2511
(MediaTek : MT7921AU)

Wifi module

客户认可 Custom Approval Section		
Custom Name		
Department		
Approval		Date:

拟制 DESIGN	审核 CHECK	批准 APPROVAL
张森林	秦楠	高照
2022-12-21	2022-12-21	2022-12-21

惠州高盛达科技有限公司
HUIZHOU GAOSHENGDA TECHNOLOGY CO.,LTD

广东省惠州市三栋镇惠南科技园金达路 2 号
No. 2 Jinda Road, Sandong Town, HUIZHOU, CHINA



PRODUCTS SPECIFICATION

WXT28M2511

Document revision history

Revision	Date	Approved by	Remarks
Version 1.0	2022-09-26		Draft
Version 1.1	2022-12-21		增加 2.4G 最大吞吐量



PRODUCTS SPECIFICATION

WXT28M2511

目录

目录.....	3
1. General Description	4
2. Features.....	4
3.Application Diagrams.....	5
3.1 Functional Block Diagram.....	5
3.2 General Requirements.....	5
3.2.1 IEEE 802.11b Section	5
3.2.2 IEEE 802.11g Section	6
3.2.3 IEEE 802.11a Section	6
3.2.4 IEEE 802.11n Section	7
3.2.5 IEEE 802.11ac Section	8
3.2.6 IEEE 802.11ax Section	8
3.2.7 Bluetooth Section.....	9
4.Electrical and Thermal Characteristics	9
4.1Temperature Limit Ratings.....	9
4.2General Section	9
4.3 Software	9
4.4 EEPROM Information.....	10
4.5 DC Characteristics.....	10
5. Mechanical Dimensions	10
6. Component preparation	12
7. Interface Timing Specification	12
Appendix 1: SMTconnector	12



1. General Description

This document is to specify the product requirements for 802.11a/b/g/n/ac/ax and Bluetooth USB Module. This Card is based on MediaTek MT7921 chipset. It is a complete dual-band (2.4GHz and 5GHz) WIFI 2 x2 MIMO MAC/PHY/Radio System-on-a-Chip. This module provides a high level of integration with a dual-stream IEEE 802.11ax MAC/ base band /radio. The WLAN operation supports 20MHz, 40MHz and 80MHz channels for data rates up to 1201Mbps. It is also backward compliant with IEEE 802.11a standard from 5.15~5.825GHz wideband and IEEE 802.11b/g standard from 2.4~2.5GHz. It can be used to provide up to 54Mbps for IEEE 802.11a and IEEE 802.11g, 11Mbps for IEEE 802.11b and 300Mbps for IEEE 802.11n. The Bluetooth part supports latest 5.2.

With seamless roaming, fully interoperability and advanced security with WEP standard, 802.11 a/b/g/n/ac USB 2.0 Module offers absolute interoperability with different vendors 802.11a/b/g/n/ac. Access Points through the wireless LAN.

2. Features

- Compatible with IEEE 802.11a standard to provide wireless 54Mbps data rate
- Compatible with IEEE 802.11b standard to provide wireless 11Mbps data rate
- Compatible with IEEE 802.11g standard to provide wireless 54Mbps data rate
- Compatible with IEEE 802.11n standard to provide wireless 300Mbps data rate
- Compatible with IEEE 802.11ac standard to provide wireless 866.7Mbps data rate.
- Compatible with IEEE 802.11ax standard to provide wireless 1201Mbps data rate.
- Operation at 2.4~2.5GHz and 5.15~5.825GHz frequency band to meet worldwide regulations.
- Support MU-MIMO RX .
- Bluetooth specification 2.1+EDR
- Bluetooth 5.2 Low Energy (LE)
- IEEE 802.11 d/e/h/i/j/k/m/r/v/w support
- Security support for WPA/WPA2/WPA3 personal, WPS 2.0, WAPI
- Drivers support Win10, Win8, Win7, XP, Linux
- High speed USB 2.0 interface
- High speed USB 3.0 interface
- HSF compliant

3. Application Diagrams

3.1 Functional Block Diagram

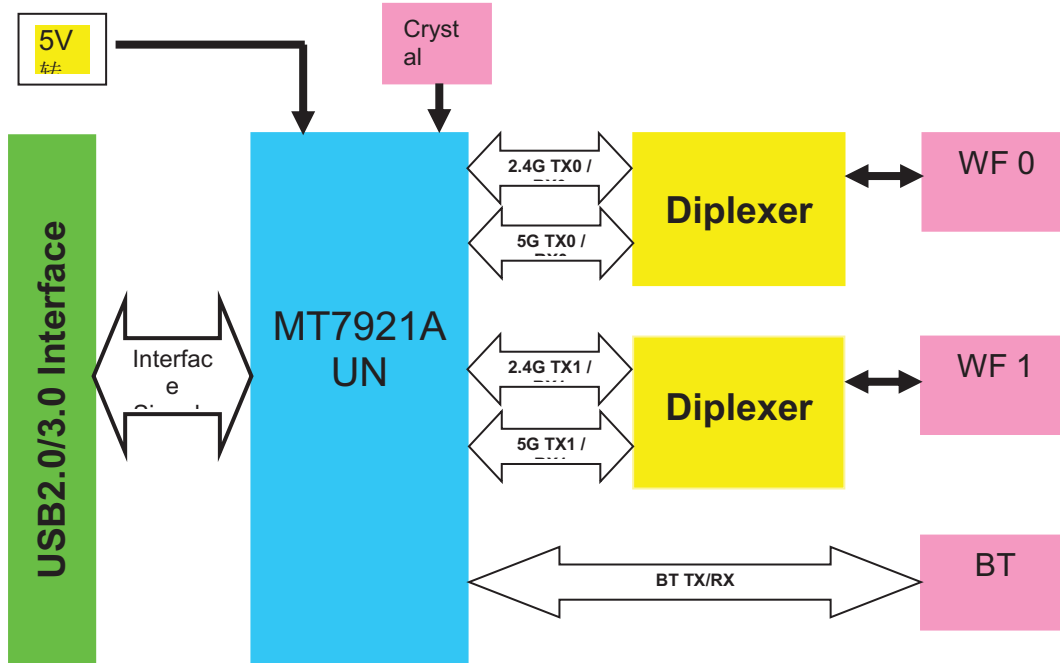

3.2 General Requirements

3.2.1 IEEE 802.11b Section

	Feature	Detailed Description
3.2.1.1	Standard	<ul style="list-style-type: none"> IEEE 802.11b
3.2.1.2	Radio and Modulation Schemes	<ul style="list-style-type: none"> DQPSK , DBPSK and CCK with DSSS
3.2.1.3	Operating Frequency	<ul style="list-style-type: none"> 2400 ~ 2483.5MHz ISM band
3.2.1.4	Channel Numbers	<ul style="list-style-type: none"> 13 channels for Worldwide
3.2.1.5	Data Rate	<ul style="list-style-type: none"> at most 11Mbps
3.2.1.6	Media Access Protocol	<ul style="list-style-type: none"> CSMA/CA with ACK
3.2.1.7	Transmitter Output Power at Antenna Connector	<ul style="list-style-type: none"> Typical RF Output Power at each RF chain, and at room Temp. 25°C 1J±F dBm at 11Mbps
3.2.1.8	Receiver Sensitivity at Antenna Connector	<ul style="list-style-type: none"> Typical Sensitivity at each RF chain. @Frame (1000-byte PDUs) Error Rate<8% at room Temp 25°C -83 dBm for 11Mbps



PRODUCTS SPECIFICATION

WXT28M2511

3.2.2 IEEE 802.11g Section

	Feature	Detailed Description
3.2.2.1	Standard	<ul style="list-style-type: none"> IEEE 802.11g
3.2.2.2	Radio and Modulation Type	<ul style="list-style-type: none"> QPSK , BPSK , 16QAM ,64QAM with OFDM
3.2.2.3	Operating Frequency	<ul style="list-style-type: none"> 2400 ~ 2483.5MHz ISM band
3.2.2.4	Channel Numbers	<ul style="list-style-type: none"> 13 channels for Worldwide
3.2.2.5	Data Rate	<ul style="list-style-type: none"> at most 54Mbps
3.2.2.6	Media Access Protocol	<ul style="list-style-type: none"> CSMA/CA with ACK
3.2.2.7	Transmitter Output Power at Antenna Connector	<ul style="list-style-type: none"> Typical RF Output Power at each RF chain, at room Temp. 25°C 14±F dBm at 54Mbps
3.2.2.8	Receiver Sensitivity at Antenna Connector	<ul style="list-style-type: none"> Typical Sensitivity at each RF chain. @Frame (1000-byte PDUs) Error Rate<10% at room Temp 25°C -71 dBm for 54Mbps

3.2.3 IEEE 802.11a Section

	Feature	Detailed Description
3.2.3.1	Standard	<ul style="list-style-type: none"> IEEE 802.11a
3.2.3.2	Radio and Modulation Type	<ul style="list-style-type: none"> QPSK , BPSK , 16QAM ,64QAM with OFDM
3.2.3.3	Operating Frequency	<ul style="list-style-type: none"> 5.15~5.25GHz 5.25~5.35GHz 5.47~5.725GHz 5.725~5.825GHz
3.2.3.4	Data Rate	<ul style="list-style-type: none"> at most 54Mbps
3.2.3.5	Media Access Protocol	<ul style="list-style-type: none"> CSMA/CA with ACK
3.2.3.6	Transmitter Output Power at Antenna Connector	<ul style="list-style-type: none"> Typical RF Output Power at each RF chain, at room Temp. 25°C 14±F dBm at 54Mbps
3.2.3.7	Receiver Sensitivity at Antenna Connector	<ul style="list-style-type: none"> Typical Sensitivity at each RF chain. @Frame (1000-byte PDUs) Error Rate<10% at room Temp 25°C -71 dBm for 54Mbps



PRODUCTS SPECIFICATION

WXT28M2511

3.2.4 IEEE 802.11n Section

	Feature	Detailed Description	
3.2.4.1	Standard	<ul style="list-style-type: none"> IEEE 802.11n 	
3.2.4.2	Radio and Modulation Type	<ul style="list-style-type: none"> BPSK , QPSK , 16QAM ,64QAM with OFDM 	
3.2.4.3	Operating Frequency	<ul style="list-style-type: none"> 2.4GHz :2400 ~ 2483.5MHz for ISM band 5GHz : 5.15~5.25GHz; 5.25~5.35GHz; 5.47~5.725GHz; 5.725~5.825GHz; 	
3.2.4.4	Data Rate	at most 300 Mbps	
3.2.4.5	Media Access Protocol	<ul style="list-style-type: none"> CSMA/CA with ACK 	
3.2.4.6	Transmitter Output Power at Antenna Connector	<ul style="list-style-type: none"> Typical RF Output Power at each RF chain,and at roomTemp. 25°C 	
		<ul style="list-style-type: none"> 2.4GHz Band/HT20 14±FdBm at MCS7 	<ul style="list-style-type: none"> 2.4GHz Band/HT40 14±FdBm at MCS7
		<ul style="list-style-type: none"> 5GHz Band/HT20 13±FdBm at MCS7 	<ul style="list-style-type: none"> 5GHz Band/HT40 13±FdBm at MCS7
3.2.4.7	Receiver Sensitivity at Antenna Connector	Typical Sensitivity at each RF chain. @Frame(1000-byte PDUs)Error Rate=10% and at room Temp. 25°C	
		2.4GHz Band/HT20 <ul style="list-style-type: none"> -68dBm at MCS7 	2.4GHz Band/HT40 <ul style="list-style-type: none"> -66dBm at MCS7
		5GHz Band/HT20 <ul style="list-style-type: none"> -68dBmat MCS7 	5GHz Band/HT40 <ul style="list-style-type: none"> -66dBm at MCS7



PRODUCTS SPECIFICATION

WXT28M2511

3.2.5 IEEE 802.11ac Section

	Feature	Detailed Description				
3.2.5.1	Standard	<ul style="list-style-type: none"> IEEE 802.11ac 				
3.2.5.2	Radio and Modulation Type	<ul style="list-style-type: none"> QPSK , BPSK , 16QAM ,64QAM,256QAM with OFDM 				
3.2.5.3	Operating Frequency	<ul style="list-style-type: none"> 5GHz : 5.15~5.25GHz; 5.25~5.35GHz; 5.47~5.725GHz; 5.725~5.825GHz; 				
3.2.5.4	Data Rate	<ul style="list-style-type: none"> at most 866.7 Mbps 				
3.2.5.5	Media Access Protocol	<ul style="list-style-type: none"> CSMA/CA with ACK 				
3.2.5.6	Transmitter Output Power at Antenna Connector	<ul style="list-style-type: none"> Typical RF Output Power at each RF chain, at room Temp. 25°C 1 8 ± 1dBm HT80 at MCS9 				
3.2.5.7	Receiver Sensitivity at Antenna Connector	Typical Sensitivity at each RF chain. @Frame(1000-byte PDU)Error Rate<10% at room Temp 25°C				
		<table border="1"> <tr> <td>5GHz Band / HT20</td> <td>5GHz Band / HT40</td> </tr> <tr> <td> <ul style="list-style-type: none"> -64dBm at MCS8 </td> <td> <ul style="list-style-type: none"> -58dBm at MCS9 </td> </tr> </table>	5GHz Band / HT20	5GHz Band / HT40	<ul style="list-style-type: none"> -64dBm at MCS8 	<ul style="list-style-type: none"> -58dBm at MCS9
		5GHz Band / HT20	5GHz Band / HT40			
<ul style="list-style-type: none"> -64dBm at MCS8 	<ul style="list-style-type: none"> -58dBm at MCS9 					
<table border="1"> <tr> <td>5GHz Band / HT80</td> <td></td> </tr> <tr> <td> <ul style="list-style-type: none"> -55dBm at MCS9 </td> <td></td> </tr> </table>	5GHz Band / HT80		<ul style="list-style-type: none"> -55dBm at MCS9 			
5GHz Band / HT80						
<ul style="list-style-type: none"> -55dBm at MCS9 						

3.2.6 IEEE 802.11ax Section

	Feature	Detailed Description				
3.2.6.1	Standard	<ul style="list-style-type: none"> IEEE 802.11ax 				
3.2.6.2	Radio and Modulation Type	<ul style="list-style-type: none"> QPSK , BPSK , 16QAM ,64QAM,256QAM, 1024QAM 				
3.2.6.3	Operating Frequency	<ul style="list-style-type: none"> 2G: 2400 ~ 2483.5MHz ISM band 5GHz : 5.15~5.25GHz; 5.25~5.35GHz; 5.47~5.725GHz; 5.725~5.825GHz; 				
3.2.6.4	Data Rate	<ul style="list-style-type: none"> 2.4G: at most 573.5 Mbps 5G: at most 1201 Mbps 				
3.2.6.5	Media Access Protocol	<ul style="list-style-type: none"> CSMA/CA with ACK 				
3.2.6.6	Transmitter Output Power at Antenna Connector	<ul style="list-style-type: none"> Typical RF Output Power at each RF chain, at room Temp. 25°C 1 6 ± 1dBm HT80 at MCS11 				
3.2.6.7	Receiver Sensitivity at Antenna Connector	Typical Sensitivity at each RF chain. @Frame(1000-byte PDU)Error Rate<10% at room Temp 25°C				
		<table border="1"> <tr> <td>2GHz Band / HT20</td> <td>2GHz Band / HT40</td> </tr> <tr> <td> <ul style="list-style-type: none"> -57dBm at MCS11 </td> <td> <ul style="list-style-type: none"> -55dBm at MCS11 </td> </tr> </table>	2GHz Band / HT20	2GHz Band / HT40	<ul style="list-style-type: none"> -57dBm at MCS11 	<ul style="list-style-type: none"> -55dBm at MCS11
		2GHz Band / HT20	2GHz Band / HT40			
		<ul style="list-style-type: none"> -57dBm at MCS11 	<ul style="list-style-type: none"> -55dBm at MCS11 			
<table border="1"> <tr> <td>5GHz Band / HT20</td> <td>5GHz Band / HT40</td> </tr> <tr> <td> <ul style="list-style-type: none"> -57dBm at MCS11 </td> <td> <ul style="list-style-type: none"> -55dBm at MCS11 </td> </tr> </table>	5GHz Band / HT20	5GHz Band / HT40	<ul style="list-style-type: none"> -57dBm at MCS11 	<ul style="list-style-type: none"> -55dBm at MCS11 		
5GHz Band / HT20	5GHz Band / HT40					
<ul style="list-style-type: none"> -57dBm at MCS11 	<ul style="list-style-type: none"> -55dBm at MCS11 					
<table border="1"> <tr> <td>5GHz Band / HT80</td> <td></td> </tr> <tr> <td> <ul style="list-style-type: none"> -53dBm at MCS11 </td> <td></td> </tr> </table>	5GHz Band / HT80		<ul style="list-style-type: none"> -53dBm at MCS11 			
5GHz Band / HT80						
<ul style="list-style-type: none"> -53dBm at MCS11 						



PRODUCTS SPECIFICATION

WXT28M2511

3.2.7 Bluetooth Section

Feather		Description	
General specification			
Bluetooth standard	Bluetooth V2.1/4.2/5.2		
Frequency band	2402MHz-2480MHz		
Channel Numbers	79 channels for BDR+EDR 40 channels for BLE		
Modulation	GFSK, $\pi/4$ -DQPSK and 8DPSK		
RF specification			
	Min (dBm)	Type (dBm)	Max (dBm)
BDR Output Power		9	
BLE Output Power		5	
Sensitive @BER=0.1% FOR GFSK(1Mbps)		-86	
Sensitive @BER=0.01% FOR $\pi/4$ -DQPSK(2Mbps)		-86	
Sensitive @BER=0.01% FOR 8DPSK(3Mbps)		-80	
Maximum input level	GFSK(1Mbps) -20dBm		
	$\pi/4$ -DQPSK(2Mbps) -20dBm		
	8DQPSK(3Mbps) -20dBm		
Sensitive @PER=30.8% FOR BLE		-90	

4. Electrical and Thermal Characteristics

4.1 Temperature Limit Ratings

Parameter	Minimum	Maximum	Units
Storage Temperature	-40	+80	C
Ambient Operating Temperature	0	70	C
Junction Temperature	0	125	C

4.2 General Section

	Feature	Detailed Description
4.2.1	Antenna Type	<ul style="list-style-type: none"> WIFI&BT: PCB Antenna
4.2.2	Operating Voltage	<ul style="list-style-type: none"> 5V\pm10%
4.2.3	Current Consumption	<ul style="list-style-type: none"> <300mA@RX <2000mA@TX
4.2.4	Form Factor and Interface	<ul style="list-style-type: none"> High Speed USB3.0/USB2.0 Interface

4.3 Software

Driver	Win10,Win8,Win7, XP, Linux, MAC
Security	64/128-bits WEP, WPA, WPA2

4.4 EEPROM Information BT

Vendor ID	0E8D
Product ID	7961

WiFi

Reg Domain	Worldwide 2.4G/5G Read from registry; Control by driver
Vendor ID	0E8D
Product ID	7961

4.5 DC Characteristics

Symbol	Parameter	Min	TYPE	Max	Unit
V_{IL}	Input Low Voltage	-0.3		$V_{DD3.3} * 0.25$	V
V_{IH}	Input High Voltage	$V_{DD3.3} * 0.625$		$V_{DD3.3} + 0.3$	V
V_{OL}	Output Low Voltage	-0.3		0.4	V
V_{OH}	Output High Voltage	$V_{DD3.3} - 0.4$		$V_{DD3.3} + 0.3$	V

5. Mechanical Dimensions

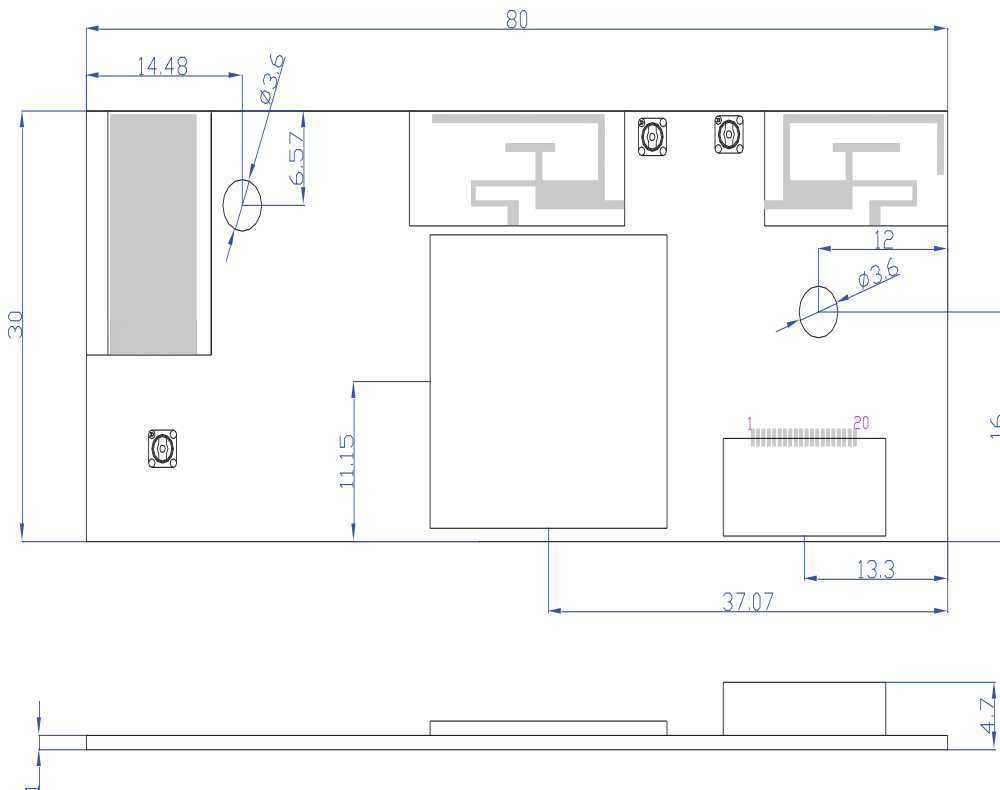



PRODUCTS SPECIFICATION

WXT28M2511

Pin	Symbol	DESCRIPTION	I/O
1	GND	GND	-
2	GND	GND	-
3	GND	GND	-
4	USB3_TX-	USB3.0	O
5	USB3_TX+	USB3.0	O
6	GND	GND	-
7	USB3_RX-	USB3.0	I
8	USB3_RX+	USB3.0	I
9	GND	GND	-
10	GND	GND	-
11	D+	USB Communication signal USB-DP)	I/O
12	D-	USB Communication signal USB-DM	I/O
13	GND	GND	-
14	GPI01	BT/WIFI wake up host (内有10K电阻上拉到3.3V), 低电平有效	O
15	RESET	Reset controlled by main SOC (内有10K电阻上拉到3.3V), 低电平有效	I
16	5V	Power supply	-
17	5V	Power supply	-
18	5V	Power supply	-
19	5V	Power supply	-
20	5V	Power supply	-

尺寸误差范围:

长度(mm)	误差(mm)
0-5	±0.15
5-10	±0.20
10-50	±0.30
>50	±0.40

6. Component preparation

物料名称/ Type	供应商品牌/ Manufacturer
晶振/ Crystal oscillator	晶宝时频 CREC/加高 HARMONY
电阻/ Resistance	华新科 Walsin /国巨 Yageo
WIFI 芯片/IC	MTK
电容/ Capacitance	Murata (村田) /华新科 Walsin/国巨 Yageo
电感/ Inductance	Murata (村田) /奇力新 CHILISIN
功率电感	风华科技/佳邦/奇力新
印制板/PCB	富智祥/科翔/宝信欣旺/凌航达
双工器/IC	华新科/ ACX/佳利
降压管	拓尔微电子/Fiti Power/蕊源
SMT connector	昶通

7. Interface Timing Specification

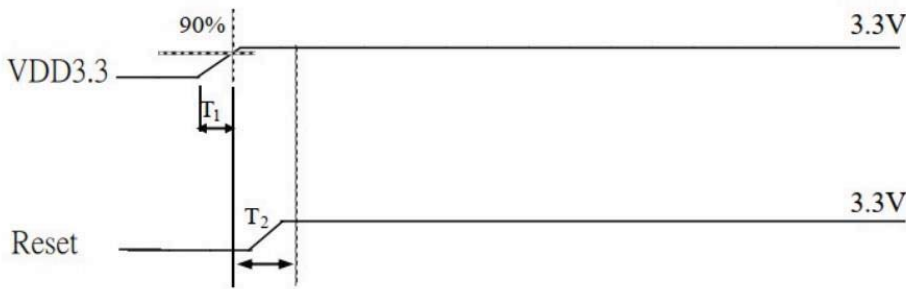

The typical timing range

	Unit	Min	Typical	Max
T ₁	ms	0.25	2	5
T ₂	ms	1	--	--

Note: T₂ must be asserted after VDD3.3 ready

**Appendix 1:
SMTconnector**

<p>禁止使用1级环境管理物质 Non-use Warranty for level 1 Prohibited Substances in Product. HF(Halogen Free)</p>	<p>版本 ISSUE A/0</p> <p>变更通知单号 ECN NO NEW RELEASE</p> <p>变更内容 DESCRIPTION NEW RELEASE</p> <p>日期 DATE 2017.12.13</p>	<p>NOTES: MATERIAL: INSULATOR: LCP PLASTIC. UL 94V-0 COLOR : NATURE COVER: THERMO-PLASTIC COLOR:BLACK TERMINAL: PHOSPHOR COPPER. CONTACT: COPPER ALLOY</p> <p>SPECIFICATION: CURRENT RATING: 0.5A 50V AC/DC CONTACT RESISTANCE: 30mΩ MAX INSULATION RESISTANCE: 100MΩ MIN AT 50V DC OPERATING TEMPERATURE RANGE: -40° C TO +85° C WITHSTANDING VOLTAGE:500V AC/minute</p> <p>料号编排说明:F050 47 - 20P - Z. 产品分类码 F050:FPC 0.5Pitch 产品系列码 47:前掀式6.0宽 Pin位码 20P:20Pin</p> <p>电镀 Z: 锌锡区被雾锡80~160u"; 接触区镀金1u"Min; 底层全区打镍底50~100u".</p> <p>NOTES 1: Lot No : 9 02 19 01 A 01. Year of manufacturing(年) (9:2019 Year, 0:2020 Year) Month of manufacturing(月) Date of manufacturing(日) Assembly machine no.(装配机台号) Time of manufacturing(班别) A: Daytime(白班), B: Night(夜班) Reel Number (盘号)</p>																																																																							
<p>① DIM A±0.15 ② DIM B±0.1 ③ 0.50±0.05 ④ 0.20±0.03 ⑤ ⑥ DIM D±0.2 ⑦ ⑧ ⑨ ⑩ ⑪ DIM C±0.03 ⑫ ⑬ ⑭ ⑮ ⑯ ⑰ ⑱</p>	<p>⑲ 0.63±0.15 ⑳ 0.63±0.15 ㉑ ㉒ ㉓ ㉔ ㉕ ㉖</p>	<p>P. C. B Layout</p> <table border="1" style="margin-left: auto; margin-right: auto;"> <tr> <th>PIN NO.</th> <th>DIM A</th> <th>DIM B</th> <th>DIM C</th> <th>DIM D</th> </tr> <tr> <td>20</td> <td>14.90</td> <td>9.50</td> <td>10.55</td> <td>15.10</td> </tr> <tr> <td>24</td> <td>16.90</td> <td>11.50</td> <td>12.55</td> <td>17.10</td> </tr> </table>	PIN NO.	DIM A	DIM B	DIM C	DIM D	20	14.90	9.50	10.55	15.10	24	16.90	11.50	12.55	17.10																																																								
PIN NO.	DIM A	DIM B	DIM C	DIM D																																																																					
20	14.90	9.50	10.55	15.10																																																																					
24	16.90	11.50	12.55	17.10																																																																					
<table border="1" style="width:100%; border-collapse: collapse;"> <tr> <td>5</td> <td>右接地片</td> <td>1</td> <td>COPPER ALLOY</td> <td>雾锡</td> <td>冲压件</td> </tr> <tr> <td>4</td> <td>左接地片</td> <td>1</td> <td>COPPER ALLOY</td> <td>雾锡</td> <td>冲压件</td> </tr> <tr> <td>3</td> <td>端子</td> <td>**</td> <td>PHOSPHOR COPPER</td> <td>半金锡</td> <td>冲压件</td> </tr> <tr> <td>2</td> <td>掀盖</td> <td>1</td> <td>GLASS FILLED THERMO-PLASTIC</td> <td>黑色</td> <td>成型件</td> </tr> <tr> <td>1</td> <td>塑胶主体</td> <td>1</td> <td>GLASS FILLED THERMO-PLASTIC</td> <td>白色</td> <td>成型件</td> </tr> <tr> <td>项次</td> <td>名称</td> <td>数量</td> <td>材质</td> <td>电镀(或颜色)</td> <td>备注</td> </tr> </table>	5	右接地片	1	COPPER ALLOY	雾锡	冲压件	4	左接地片	1	COPPER ALLOY	雾锡	冲压件	3	端子	**	PHOSPHOR COPPER	半金锡	冲压件	2	掀盖	1	GLASS FILLED THERMO-PLASTIC	黑色	成型件	1	塑胶主体	1	GLASS FILLED THERMO-PLASTIC	白色	成型件	项次	名称	数量	材质	电镀(或颜色)	备注	<table border="1" style="width:100%; border-collapse: collapse;"> <tr> <td colspan="2">C*T 东莞市昶通通讯科技有限公司</td> <td colspan="2">CONNECTOR Dongguan Changtong Communication Technology CO., Ltd</td> </tr> <tr> <td>品名</td> <td>FPC 0.5Pitch 2.0H</td> <td>类型</td> <td>业务图</td> </tr> <tr> <td>TITLE</td> <td>6.0mm wide connector</td> <td>TYPE</td> <td>F05047-**P-Z</td> </tr> <tr> <td>制 图</td> <td>钟超红2017.12.13</td> <td>产品料号</td> <td></td> </tr> <tr> <td>DESIGNER</td> <td>X.X ±0.25</td> <td>PRODUCT P/N</td> <td></td> </tr> <tr> <td>审 核</td> <td>X.XX ±0.15</td> <td>材 质</td> <td></td> </tr> <tr> <td>CHECKED</td> <td>龙以彪2017.12.13</td> <td>ANGLE</td> <td></td> </tr> <tr> <td>核 准</td> <td>龙以彪2017.12.13</td> <td>投影方法</td> <td>比例</td> </tr> <tr> <td>APPROVED</td> <td></td> <td>PROJECTION</td> <td>SCALE 1:1 张次 1/3</td> </tr> </table>	C*T 东莞市昶通通讯科技有限公司		CONNECTOR Dongguan Changtong Communication Technology CO., Ltd		品名	FPC 0.5Pitch 2.0H	类型	业务图	TITLE	6.0mm wide connector	TYPE	F05047-**P-Z	制 图	钟超红2017.12.13	产品料号		DESIGNER	X.X ±0.25	PRODUCT P/N		审 核	X.XX ±0.15	材 质		CHECKED	龙以彪2017.12.13	ANGLE		核 准	龙以彪2017.12.13	投影方法	比例	APPROVED		PROJECTION	SCALE 1:1 张次 1/3
5	右接地片	1	COPPER ALLOY	雾锡	冲压件																																																																				
4	左接地片	1	COPPER ALLOY	雾锡	冲压件																																																																				
3	端子	**	PHOSPHOR COPPER	半金锡	冲压件																																																																				
2	掀盖	1	GLASS FILLED THERMO-PLASTIC	黑色	成型件																																																																				
1	塑胶主体	1	GLASS FILLED THERMO-PLASTIC	白色	成型件																																																																				
项次	名称	数量	材质	电镀(或颜色)	备注																																																																				
C*T 东莞市昶通通讯科技有限公司		CONNECTOR Dongguan Changtong Communication Technology CO., Ltd																																																																							
品名	FPC 0.5Pitch 2.0H	类型	业务图																																																																						
TITLE	6.0mm wide connector	TYPE	F05047-**P-Z																																																																						
制 图	钟超红2017.12.13	产品料号																																																																							
DESIGNER	X.X ±0.25	PRODUCT P/N																																																																							
审 核	X.XX ±0.15	材 质																																																																							
CHECKED	龙以彪2017.12.13	ANGLE																																																																							
核 准	龙以彪2017.12.13	投影方法	比例																																																																						
APPROVED		PROJECTION	SCALE 1:1 张次 1/3																																																																						

FCC Statement

This device complies with part 15 of the FCC rules. Operation is subject to the following two conditions: (1) this device may not cause harmful interference, and (2) this device must accept any interference received, including interference that may cause undesired operation.

Changes or modifications not expressly approved by the party responsible for compliance could void the user's authority to operate the equipment.

NOTE: This equipment has been tested and found to comply with the limits for a Class B digital device, pursuant to part 15 of the FCC Rules. These limits are designed to provide reasonable protection against harmful interference in a residential installation. This equipment generates uses and can radiate radio frequency energy and, if not installed and used in accordance with the instructions, may cause harmful interference to radio communications. However, there is no guarantee that interference will not occur in a particular installation. If this equipment does cause harmful interference to radio or television reception, which can be determined by turning the equipment off and on, the user is encouraged to try to correct the interference by one or more of the following measures:

- Reorient or relocate the receiving antenna.
- Increase the separation between the equipment and receiver.
- Connect the equipment into an outlet on a circuit different from that to which the receiver is connected.
- Consult the dealer or an experienced radio/TV technician for help important announcement

Important Note:

Radiation Exposure Statement

This equipment complies with FCC radiation exposure limits set forth for an uncontrolled environment. This equipment should be installed and operated with minimum distance 20cm between the radiator and your body.

This transmitter must not be co-located or operating in conjunction with any other antenna or transmitter.

Country Code selection feature to be disabled for products marketed to the US/Canada.

This device is intended only for OEM integrators under the following conditions:

1. The antenna must be installed such that 20 cm is maintained between the antenna and users, and
2. The transmitter module may not be co-located with any other transmitter or antenna,
3. For all products market in US, OEM has to limit the operation channels in CH1 to CH11 for 2.4G band by supplied firmware programming tool. OEM shall not supply any tool or info to the end-user regarding to Regulatory Domain change. (if modular only test Channel 1-11)

As long as the three conditions above are met, further transmitter testing will not be required. However, the OEM integrator is still responsible for testing their end-product for any additional compliance requirements required with this module installed.

Important Note:

In the event that these conditions cannot be met (for example certain laptop configurations or co-location with another transmitter), then the FCC authorization is no longer considered valid and the FCC ID cannot be used on the final product. In these circumstances, the OEM integrator will be responsible for re-evaluating the end product (including the transmitter) and obtaining a separate FCC authorization.

End Product Labeling

The final end product must be labeled in a visible area with the following" Contains

FCC ID: **2A94K-WXT28M2511**"

Manual Information to the End User

The OEM integrator has to be aware not to provide information to the end user regarding how to install or remove this RF module in the user's manual of the end product which integrates this module.

The end user manual shall include all required regulatory information/warning as show in this manual.

Integration instructions for host product manufacturers according to KDB 996369 D03 OEM Manual v01

2.2 List of applicable FCC rules

CFR 47 FCC PART 15 SUBPART C has been investigated. It is applicable to the modular transmitter

2.3 Specific operational use conditions

This module is stand-alone modular. If the end product will involve the Multiple simultaneously transmitting condition or different operational conditions for a stand-alone modular transmitter in a host, host manufacturer have to consult with module manufacturer for the installation method in end system.

2.4 Limited module procedures

Not applicable

2.5 Trace antenna designs

Not applicable

2.6 RF exposure considerations

This equipment complies with FCC radiation exposure limits set forth for an uncontrolled environment. This equipment should be installed and operated with minimum distance 20cm between the radiator & your body.

2.7 Antennas

This radio transmitter **FCC ID:2A94K-WXT28M2511** has been approved by Federal Communications Commission to operate with the antenna types listed below, with the maximum permissible gain indicated. Antenna types not included in this list that have a gain greater than the maximum gain indicated for any type listed are strictly prohibited for use with this device.

Antenna No.	Type of antenna:	Gain of the antenna (Max.)	Frequency range:
2.4GWiFi	PCB Antenna	ANT0:2.93dBi ANT1:3.27dBi	2412-2462MHz
5GWLAN	PCB Antenna	ANT0:3.72dBi ANT1:3.86dBi	5180-5825MHz
BLE&BT	PCB Antenna	2dBi	2402-2480MHz

2.8 Label and compliance information

The final end product must be labeled in a visible area with the following" Contains **FCC ID:2A94K-WXT28M2511**".

2.9 Information on test modes and additional testing requirements

Host manufacturer is strongly recommended to confirm compliance with FCC requirements for the transmitter when the module is installed in the host.

2.10 Additional testing, Part 15 Subpart B disclaimer

Host manufacturer is responsible for compliance of the host system with module installed with all other applicable requirements for the system such as Part 15 B.