

TEST REPORT

Report No.: BCTC2408633035-5E

Applicant: Acer India PVT Limited

Product Name: Tablet

Test Model: Acer Iconia Tab iM10-22

Tested Date: 2024-08-07 to 2024-09-13

Issued Date: 2024-09-13

Shenzhen BCTC Testing Co., Ltd.



FCC ID: 2A94K-IM10-22

Product Name: Tablet

Trademark: 

Model/Type reference: Acer Iconia Tab iM10-22
Acer One T10-22L

Prepared For: Acer India PVT Limited

Address: Acer India PVT Limited, 6th Floor, Embassy Heights, No.13, Magrath Road,
Bangalore, 560025, India

Manufacturer: Acer India PVT Limited

Address: RS No.38/2, Sedarapet Village Villianur Commune, Pondicherry 605111

Prepared By: Shenzhen BCTC Testing Co., Ltd.

Address: 1-2/F., Building B, Pengzhou Industrial Park, No.158, Fuyuan 1st Road,
Zhancheng, Fuhai Subdistrict, Bao'an District, Shenzhen, Guangdong, China

Sample Received Date: 2024-08-07

Sample tested Date: 2024-08-07 to 2024-09-13

Issue Date: 2024-09-13

Report No.: BCTC2408633035-5E

Test Standards: FCC CFR Title 47 Part 2
FCC CFR Title 47 Part22 Subpart H
FCC CFR Title 47 Part24 Subpart E
ANSI/ TIA/ EIA-603-D-2010
FCC KDB 971168 D01 Power Meas. License Digital Systems v03v01

Test Results: PASS

Remark: This is GSM radio test report.

Tested by:

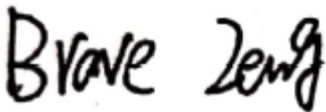

Brave Zeng/ Project Handler

Approved by:



Zero Zhou/Reviewer

The test report is effective only with both signature and specialized stamp. This result(s) shown in this report refer only to the sample(s) tested. Without written approval of Shenzhen BCTC Testing Co., Ltd, this report can't be reproduced except in full. The tested sample(s) and the sample information are provided by the client.

Table Of Content

	Page
Test Report Declaration	
1. Version	4
2. Test Summary	5
3. Measurement Uncertainty	6
4. Product Information And Test Setup	7
4.1 Product Information.....	7
4.2 Test Setup Configuration	8
4.3 Support Equipment	8
4.5 Test Mode	9
5. Test Facility And Test Instrument Used.....	10
5.1 Test Facility.....	10
5.2 Test Instrument Used.....	10
6. RF Output Power.....	12
6.1 Block Diagram Of Test Setup.....	12
6.2 Limit	13
6.3 Test procedure.....	14
6.4 Test Result.....	14
7. Peak-to-average Ratio(PAR) of Transmitter.....	18
7.1 Block Diagram Of Test Setup.....	18
7.2 Limit	18
7.3 Test procedure.....	18
7.4 Test Result.....	18
8. Emission Bandwidth	29
8.1 Block Diagram Of Test Setup.....	29
8.2 Limit	29
8.3 Test procedure.....	29
8.4 Test Result.....	29
9. Out of Band Emissions at Antenna Terminal.....	40
9.1 Block Diagram Of Test Setup.....	40
9.2 Limit	40
9.3 Test procedure.....	40
9.4 Test Result.....	40
10. Spurious Radiated Emissions.....	56
10.1 Block Diagram Of Test Setup.....	56
10.2 Limit	57
10.3 Test procedure.....	57
10.4 Test Result.....	58
11. Frequency Stability.....	59
11.1 Block Diagram Of Test Setup.....	59
11.2 Limit	59
11.3 Test procedure.....	59
11.4 Test Result.....	60
12. EUT Photographs.....	61
13. EUT Test Setup Photographs.....	62

(Note: N/A Means Not Applicable)

1. Version

Report No.	Issue Date	Description	Approved
BCTC2408633035-5E	2024-09-13	Original	Valid

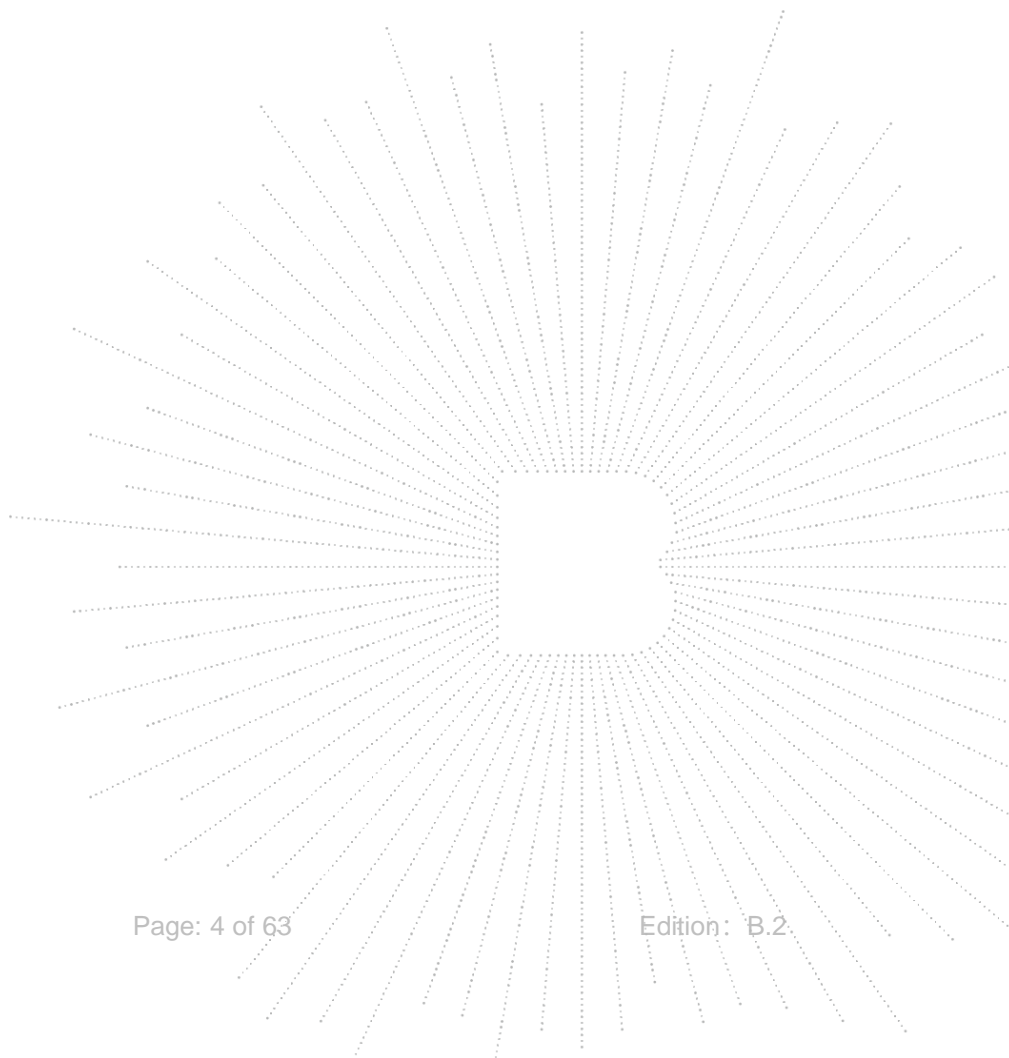

2. Test Summary

The Product has been tested according to the following specifications:

No.	Test Parameter	Clause No.	Results
1	RF Exposure	§1.1307,§2.1093	PASS
2	RF Output Power	§22.913 (a), §24.232 (c),	PASS
3	Peak-to-average Ratio(PAR) of Transmitter	§24.232(d),§22.913,	PASS
4	Emission Bandwidth	§22.917 (b), §24.238(b),	PASS
5	Spurious Emissions at Antenna Terminal	§22.917 (a), §24.238 (a),	PASS
6	Spurious Radiation Emissions	§22.917 (a), §24.238 (a),	PASS
7	Out of Band Emissions	§22.917 (a), §24.238 (a),	PASS
8	Frequency Stability	§22.355, §24.235,	PASS

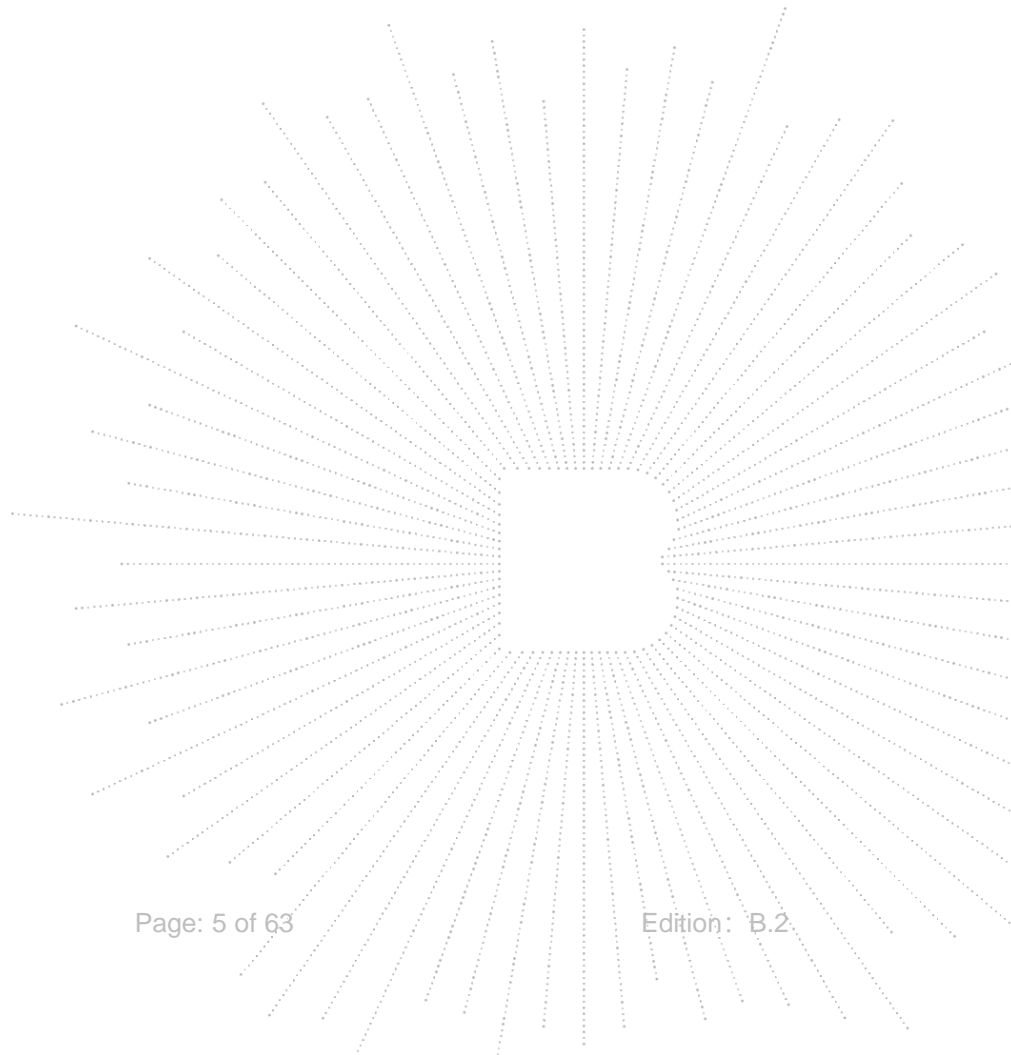

3. Measurement Uncertainty

Where relevant, the following measurement uncertainty levels have been estimated for tests performed on the Product as specified in CISPR 16-4-2. This uncertainty represents an expanded uncertainty expressed at approximately the 95% confidence level using a coverage factor of $k=2$.

No.	Item	Uncertainty
1	3m chamber Radiated spurious emission(30MHz-1GHz)	U=4.3dB
2	3m chamber Radiated spurious emission(9KHz-30MHz)	U=3.7dB
3	3m chamber Radiated spurious emission(1GHz-18GHz)	U=4.5dB
4	3m chamber Radiated spurious emission(18GHz-40GHz)	U=3.34dB
5	Conducted Emission (150kHz-30MHz)	U=3.20dB
6	Conducted Adjacent channel power	U=1.38dB
7	Conducted output power uncertainty Above 1G	U=1.576dB
8	Conducted output power uncertainty below 1G	U=1.28dB
9	humidity uncertainty	U=5.3%
10	Temperature uncertainty	U=0.59°C

4. Product Information And Test Setup

4.1 Product Information

Model/Type Reference:	Acer Iconia Tab iM10-22 Acer One T10-22L
Model Differences:	All the model are the same circuit and RF module, except model names.
Hardware Version:	N/A
Software Version:	N/A
Operation Frequency:	GSM/GPRS/EGPRS 850: TX: 824~849MHz; RX: 869~894MHz; GSM/GPRS/EGPRS 1900: TX:1850~1910MHz; RX:1930~1990MHz;
GPRS Class:	Class 12
Max RF Output Power:	GSM/GPRS/EGPRS 850: 32.71 dBm, GSM/GPRS/EGPRS 1900: 29.12 dBm
Type of Modulation:	GSM with GMSK Modulation GSM/GPRS 850: 254GXW EGPRS 850:252G7W
Type of Emission:	GSM/GPRS 1900: 249KGXW EGPRS 1900:244KG7W
Antenna installation:	Internal antenna GSM850: 1.86 dBi GSM1900: 0.11 dBi
Antenna Gain:	Remark: <input type="checkbox"/> The antenna gain of the product comes from the antenna report provided by the customer, and the test data is affected by the customer information. <input checked="" type="checkbox"/> The antenna gain of the product is provided by the customer, and the test data is affected by the customer information.
Connecting I/O Port(s)	Please refer to the User's Manual
Ratings:	DC 9V from adapter/DC 3.8V from battery Model: TPD-203A120167VF01
Adapter Information:	Input: 100-240V~50/60Hz 0.6A USB-C Output: 5.0V ===3.0A or 9.0V ===2.22A or 12.0V ===1.67A

4.2 Test Setup Configuration

See test photographs attached in *EUT TEST SETUP PHOTOGRAPHS* for the actual connections between Product and support equipment.

4.3 Support Equipment

No.	Device Type	Brand	Model	Series No.	Note
E-1	Tablet		Acer Iconia Tab iM10-22	N/A	EUT
E-2	Adapter	N/A	TPD-203A120167 VF01	N/A	Auxiliary

Item	Shielded Type	Ferrite Core	Length	Note
C-1	N/A	N/A	1M	DC cable unshielded

Notes:

1. All the equipment/cables were placed in the worst-case configuration to maximize the emission during the test.
2. Grounding was established in accordance with the manufacturer's requirements and conditions for the intended use.

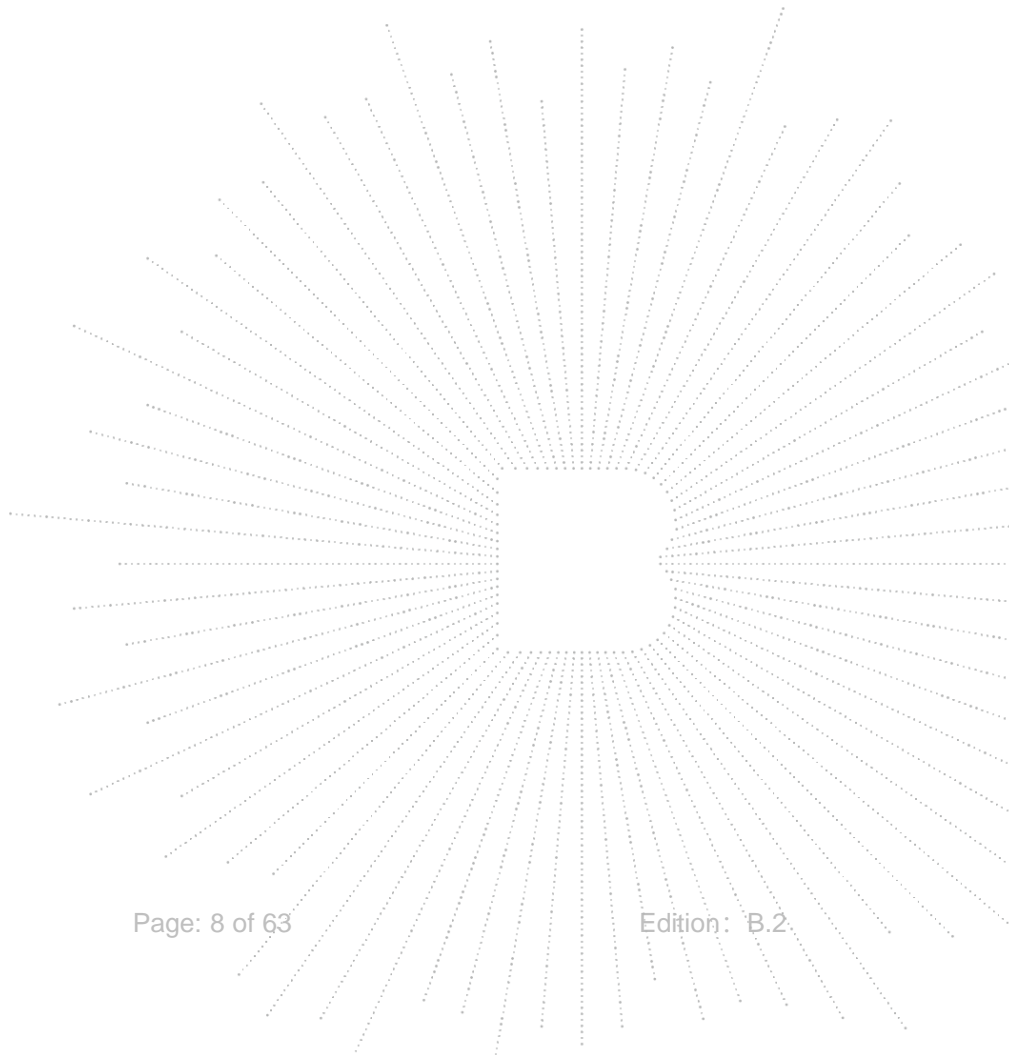

4.5 Test Mode

Testing Configure			
Support Band	Support Standard	Channel Frequency	Channel Number
GSM 850	GSM/GPRS/EGPRS	824.2 MHz	128
		836.6 MHz	190
		848.8 MHz	251
PCS 1900	GSM/GPRS/EGPRS	1850.2 MHz	512
		1880.0 MHz	661
		1909.8 MHz	810

Note 1: Both the SIM 1 and SIM 2 were tested, the worst mode is the SIM 1, the data recording in the report.

EUT Cable List and Details

Cable Description	Length (M)	Shielded/Unshielded	With Core/ Without Core
/	/	/	/
/	/	/	/

Auxiliary Equipment List and Details

Description	Manufacturer	Model	Serial Number
/	/	/	/

Special Cable List and Details

Cable Description	Length (M)	Shielded/Unshielded	With Core/ Without Core
/	/	/	/

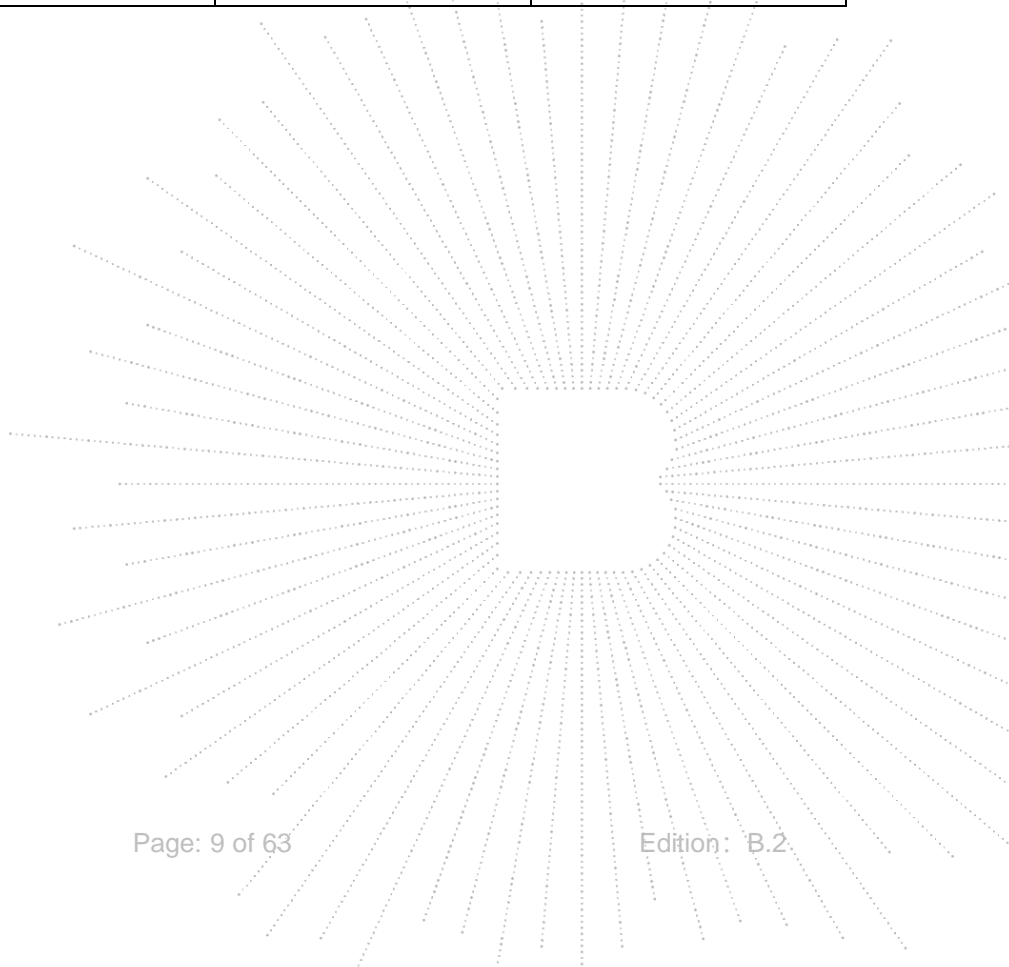

5. Test Facility And Test Instrument Used

5.1 Test Facility

All measurement facilities used to collect the measurement data are located at Shenzhen BCTC Testing Co., Ltd. Address:1-2/F., Building B, Pengzhou Industrial Park, No.158, Fuyuan 1st Road, Zhancheng, Fuhai Subdistrict, Bao'an District, Shenzhen, Guangdong, China. The site and apparatus are constructed in conformance with the requirements of ANSI C63.4 and CISPR 16-1-1 other equivalent standards.

FCC Test Firm Registration Number: 712850

A2LA certificate registration number is: CN1212

ISED Registered No.: 23583

ISED CAB identifier: CN0017

5.2 Test Instrument Used

RF Conducted Test					
Equipment	Manufacturer	Model#	Serial#	Last Cal.	Next Cal.
Power meter	Keysight	E4419	\	May 16, 2024	May 15, 2025
Power Sensor (AV)	Keysight	E9300A	\	May 16, 2024	May 15, 2025
Signal Analyzer20kHz-26.5GHz	Keysight	N9020A	MY49100060	May 16, 2024	May 15, 2025
Spectrum Analyzer9kHz-40GHz	R&S	FSP40	100363	May 16, 2024	May 15, 2025
Radio frequency control box	MAIWEI	MW100-RFCB	\	\	\
Software	MAIWEI	MTS 8310	\	\	\

Radiated Emissions Test (966 Chamber01)					
Equipment	Manufacturer	Model#	Serial#	Last Cal.	Next Cal.
966 chamber	ChengYu	966 Room	966	May 16, 2024	May 15, 2025
Receiver	R&S	ESR3	102075	May 16, 2024	May 15, 2025
Receiver	R&S	ESRP	101154	May 16, 2024	May 15, 2025
Amplifier	Schwarzbeck	BBV9744	9744-0037	May 16, 2024	May 15, 2025
TRILOG Broadband Antenna	Schwarzbeck	VULB9163	942	May 21, 2024	May 20, 2025
Loop Antenna(9KHz-30MHz)	Schwarzbeck	FMZB1519B	00014	May 21, 2024	May 20, 2025
Amplifier	SKET	LAPA_01G18 G-45dB	SK2021040901	May 16, 2024	May 15, 2025
Horn Antenna	Schwarzbeck	BBHA9120D	1541	May 21, 2024	May 20, 2025
Amplifier(18G Hz-40GHz)	MITEQ	TTA1840-35-HG	2034381	May 16, 2024	May 15, 2025
Horn Antenna(18G Hz-40GHz)	Schwarzbeck	BBHA9170	00822	May 21, 2024	May 20, 2025
Spectrum Analyzer9kHz-40GHz	R&S	FSP40	100363	May 16, 2024	May 15, 2025
Software	Frad	EZ-EMC	FA-03A2 RE	\	\

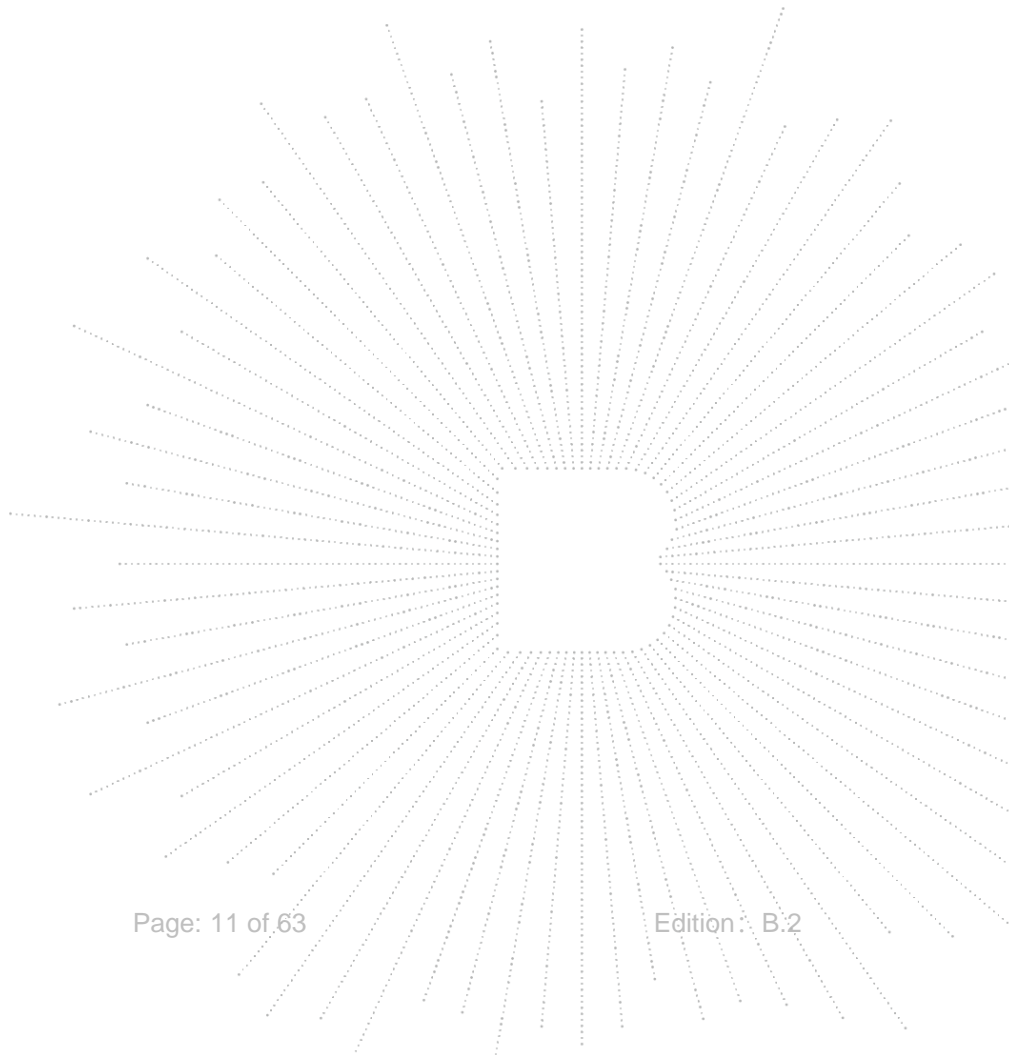

6. RF Output Power

6.1 Block Diagram Of Test Setup

Conducted output power test method:

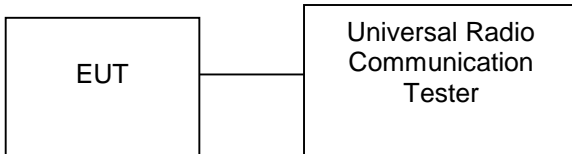

Radiated power test method:

(A) Radiated Emission Test-Up Frequency Below 30MHz

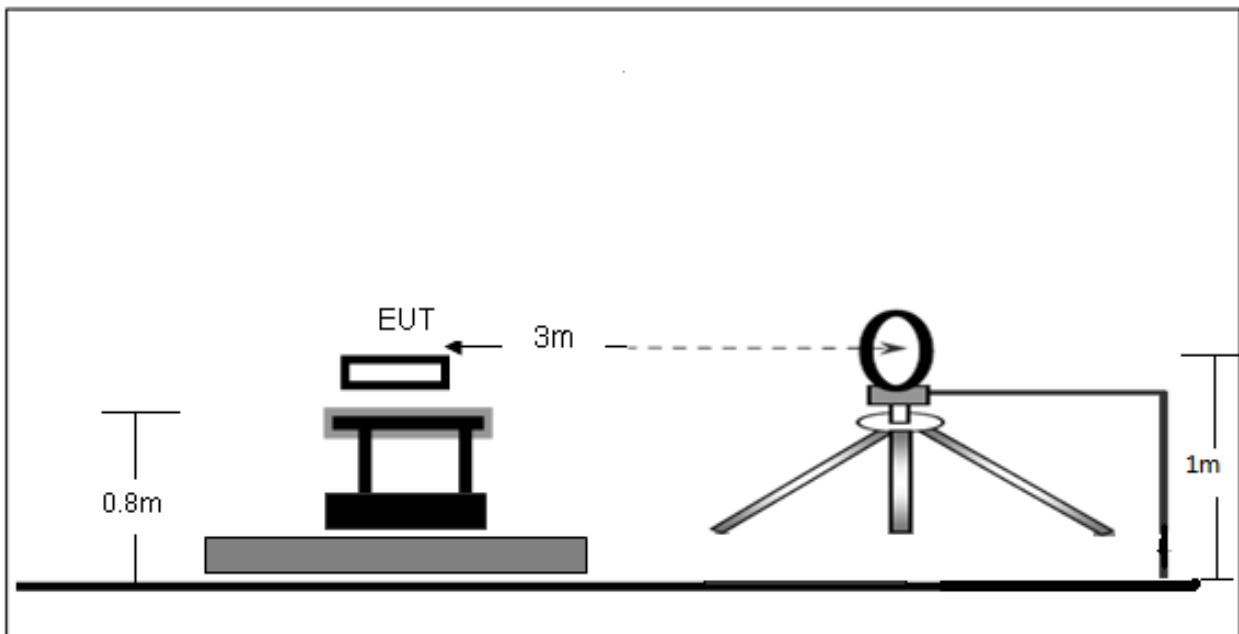

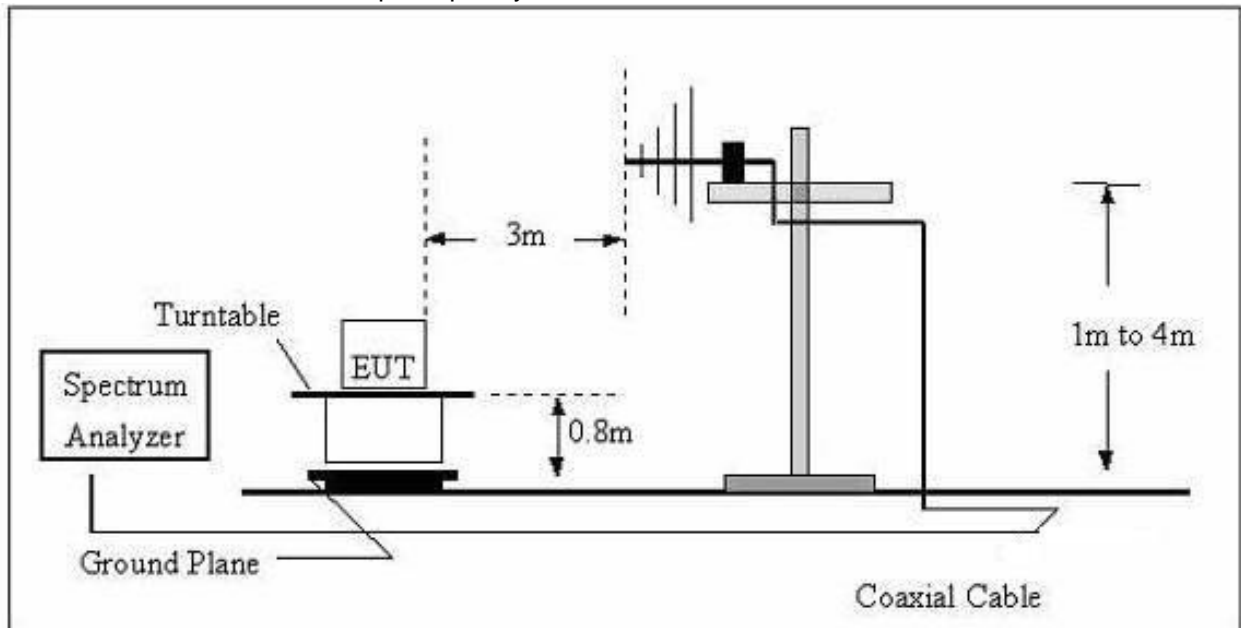
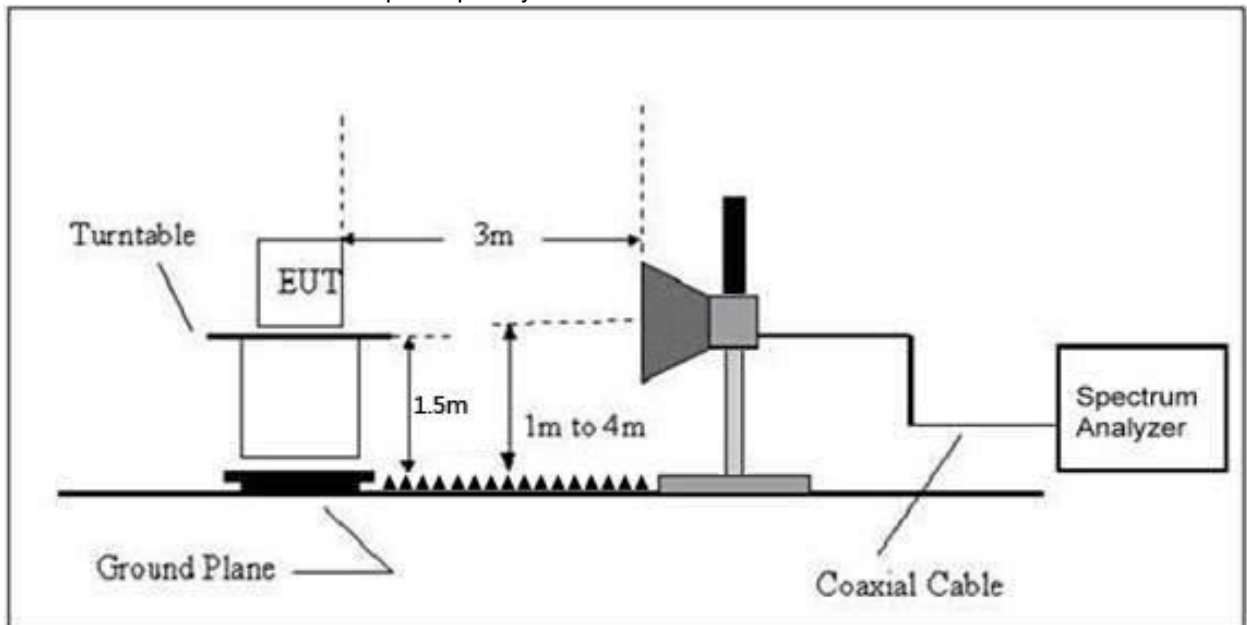
(B) Radiated Emission Test-Up Frequency 30MHz~1GHz

(C) Radiated Emission Test-Up Frequency Above 1GHz

6.2 Limit

According to §22.913(a)(2), The ERP of mobile and portable stations transmitters and auxiliary test transmitters must not exceed 7 Watts.

According to §24.232 (c), Mobile and portable stations are limited to 2 watts EIRP and the equipment must employ a means for limiting power to the minimum necessary for successful communications.

According to §27.50(d)(4), Fixed, mobile, and portable (hand-held) stations operating in the 1710-1755 MHz band and mobile and portable stations operating in the 1695-1710 MHz and 1755-1780 MHz bands are limited to 1 watt EIRP.

6.3 Test procedure

Radiated power test method:

1. The setup of EUT is according with per ANSI/TIA Standard 603D and ANSI C63.4-2014 measurement procedure.
2. The measurement antenna was placed at a distance of 3 meters from the EUT. During the tests, the antenna height and polarization as well as EUT azimuth were varied in order to identify the maximum level of emissions from the EUT. The test was performed by placing the EUT on 3-orthogonal axis.
3. The frequency range up to tenth harmonic of the fundamental frequency was investigated.
4. Remove the EUT and replace it with substitution antenna. A signal generator was connected to the substitution antenna by a non-radiating cable. The absolute levels of the spurious emissions were measured by the substitution.

6.4 Test Result

ERP For GSM Mode GSM850

Frequency (MHz)	Polar (H/V)	Height (Meter)	Table (Degree)	Reading Level (dBm)	Correct Factor (dB)	Measurement (dBm)	FCC Part 22H Limits (dBm)	Result
Low Channel								
824.2	H	1.5	0	56.42	-26.29	30.13	38.45	PASS
824.2	V	1.5	0	54.84	-26.29	28.55	38.45	PASS
Middle Channel								
836.6	H	1.5	0	55.46	-26.35	29.11	38.45	PASS
836.6	V	1.5	0	54.68	-26.35	28.33	38.45	PASS
High Channel								
848.8	H	1.5	0	55.83	-26.42	29.41	38.45	PASS
848.8	V	1.5	0	55.41	-26.42	28.99	38.45	PASS

EIRP For GSM Mode PCS1900

Frequency (MHz)	Polar (H/V)	Height (Meter)	Table (Degree)	Reading Level (dBm)	Correct Factor (dB)	Measurement (dBm)	FCC Part 24E Limits (dBm)	Result
Low Channel								
1850.2	H	1.5	0	55.91	-26.93	28.98	33.00	PASS
1850.2	V	1.5	0	54.82	-26.93	27.89	33.00	PASS
Middle Channel								
1880	H	1.5	0	54.78	-26.86	27.92	33.00	PASS
1880	V	1.5	0	54.63	-26.86	27.77	33.00	PASS
High Channel								
1909.8	H	1.5	0	54.83	-26.80	28.03	33.00	PASS
1909.8	V	1.5	0	54.99	-26.80	28.19	33.00	PASS

ERP For GPRS Mode GSM850

Frequency (MHz)	Polar (H/V)	Height (Meter)	Table (Degree)	Reading Level (dBm)	Correct Factor (dB)	Measurement (dBm)	FCC Part 22H Limits (dBm)	Result
Low Channel								
824.2	H	1.5	0	55.24	-26.29	28.95	38.45	PASS
824.2	V	1.5	0	54.98	-26.29	28.69	38.45	PASS
Middle Channel								
836.6	H	1.5	0	55.49	-26.35	29.14	38.45	PASS
836.6	V	1.5	0	55.23	-26.35	28.88	38.45	PASS
High Channel								
848.8	H	1.5	0	55.49	-26.42	29.07	38.45	PASS
848.8	V	1.5	0	54.83	-26.42	28.41	38.45	PASS

EIRP For GPRS Mode PCS1900

Frequency (MHz)	Polar (H/V)	Height (Meter)	Table (Degree)	Reading Level (dBm)	Correct Factor (dB)	Measurement (dBm)	FCC Part 24E Limits (dBm)	Result
Low Channel								
1850.2	H	1.5	0	55.29	-26.93	28.36	33.00	PASS
1850.2	V	1.5	0	54.64	-26.93	27.71	33.00	PASS
Middle Channel								
1880	H	1.5	0	55.12	-26.86	28.26	33.00	PASS
1880	V	1.5	0	55.11	-26.86	28.25	33.00	PASS
High Channel								
1909.8	H	1.5	0	55.79	-26.80	28.99	33.00	PASS
1909.8	V	1.5	0	55.39	-26.80	28.59	33.00	PASS

ERP For EGPRS Mode GSM850

Frequency (MHz)	Polar (H/V)	Height (Meter)	Table (Degree)	Reading Level (dBm)	Correct Factor (dB)	Measurement (dBm)	FCC Part 22H Limits (dBm)	Result
Low Channel								
824.2	H	1.5	0	55.56	-26.29	29.27	38.45	PASS
824.2	V	1.5	0	54.77	-26.29	28.48	38.45	PASS
Middle Channel								
836.6	H	1.5	0	55.22	-26.35	28.87	38.45	PASS
836.6	V	1.5	0	54.83	-26.35	28.48	38.45	PASS
High Channel								
848.8	H	1.5	0	55.64	-26.42	29.22	38.45	PASS
848.8	V	1.5	0	54.85	-26.42	28.43	38.45	PASS

EIRP For EGPRS Mode PCS1900

Frequency (MHz)	Polar (H/V)	Height (Meter)	Table (Degree)	Reading Level (dBm)	Correct Factor (dB)	Measurement (dBm)	FCC Part 24E Limits (dBm)	Result
Low Channel								
1850.2	H	1.5	0	55.98	-26.93	29.05	33.00	PASS
1850.2	V	1.5	0	55.76	-26.93	28.83	33.00	PASS
Middle Channel								
1880	H	1.5	0	55.73	-26.86	28.87	33.00	PASS
1880	V	1.5	0	55.31	-26.86	28.45	33.00	PASS
High Channel								
1909.8	H	1.5	0	55.22	-26.80	28.42	33.00	PASS
1909.8	V	1.5	0	54.99	-26.80	28.19	33.00	PASS

Correction Factor= S.G. Power - Cable loss + Antenna Gain- SPA. Reading

Max. Conducted Output Power

For Cellular Band (GSM850)

Band	GSM850		
Channel	128	190	251
Frequency(MHz)	824.2	836.6	848.8
GSM	32.50	32.55	32.69
GPRS Slot -1	32.52	32.56	32.71
GPRS Slot -2	31.63	31.67	31.8
GPRS Slot -3	29.67	29.72	29.89
GPRS Slot -4	28.52	28.59	28.73
EGPRS Slot -1	25.69	25.32	25.62
EGPRS Slot -2	24.7	24.2	24.42
EGPRS Slot -3	22.03	21.86	21.79
EGPRS Slot -4	20.53	20.24	20.33

For PCS Band (GSM1900)

Band	GSM1900		
Channel	512	661	810
Frequency(MHz)	1850.2	1880	1909.8
GSM	29.02	29.11	28.89
GPRS Slot -1	29.03	29.12	28.9
GPRS Slot -2	28.08	28.17	28
GPRS Slot -3	26.07	26.17	26.09
GPRS Slot -4	24.94	25.08	24.99
EGPRS Slot -1	25.05	24.41	24.42
EGPRS Slot -2	23.74	23.24	22.87
EGPRS Slot -3	20.99	20.58	20.16
EGPRS Slot -4	19.61	19.36	18.77

7. Peak-to-average Ratio(PAR) of Transmitter

7.1 Block Diagram Of Test Setup

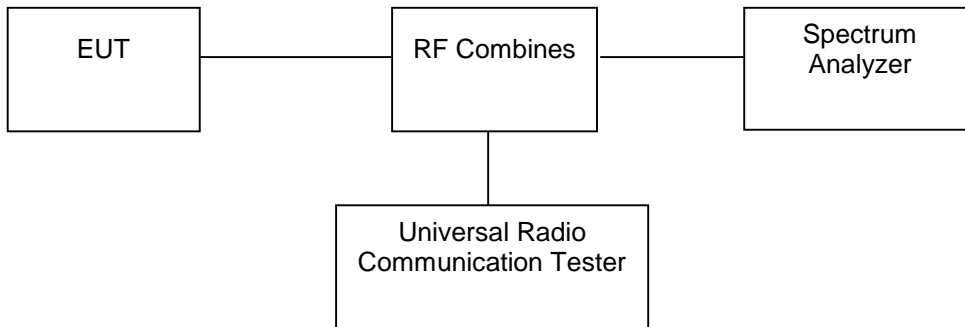

7.2 Limit

According to §24.232(d), Power measurements for transmissions by stations authorized under this section may be made either in accordance with a Commission-approved average power technique or in compliance with paragraph (e) of this section. In both instances, equipment employed must be authorized in accordance with the provisions of §24.51. In measuring transmissions in this band using an average power technique, the peak-to-average ratio (PAR) of the transmission may not exceed 13 dB.

According to §27.50(B), the peak-to-average power ratio (PAPR) of the transmitter output power must not exceed 13 dB. The PAPR measurements should be made using either an instrument with complementary cumulative distribution function (CCDF) capabilities to determine that PAPR will not exceed 13 dB for more than 0.1 percent of the time or other Commission approved procedure. The measurement must be performed using a signal corresponding to the highest PAPR expected during periods of continuous transmission.

7.3 Test procedure

The RF output terminal of the transmitter was connected to the input of the spectrum analyzer via a suitable attenuation. The RBW of the spectrum analyzer was set to 30kHz and the peak-to-average ratio (PAR) of the transmission was recorded. Record the maximum PAPR level associated with a probability of 0.1%.

7.4 Test Result

Band	Channel	Frequency (MHz)	Result (dB)	high Limit (dB)	Verdict
GSM850	128	824.2	2.68	13.00	PASS
GSM850	190	836.6	2.67	13.00	PASS
GSM850	251	848.8	2.68	13.00	PASS
GPRS850	128	824.2	2.72	13.00	PASS
GPRS850	190	836.6	2.70	13.00	PASS
GPRS850	251	848.8	2.71	13.00	PASS
EGPRS850	128	824.2	10.97	13.00	PASS
EGPRS850	190	836.6	9.06	13.00	PASS
EGPRS850	251	848.8	8.92	13.00	PASS

GSM850 Channel=128

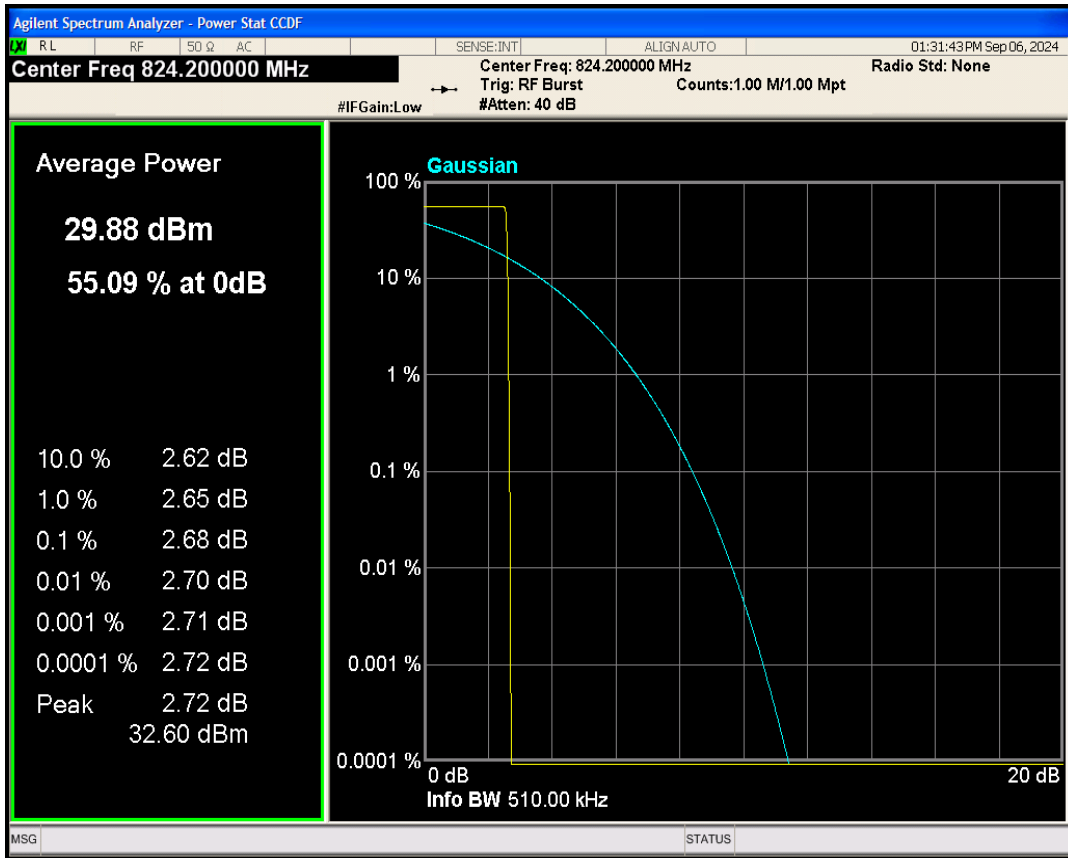

GSM850 Channel=190

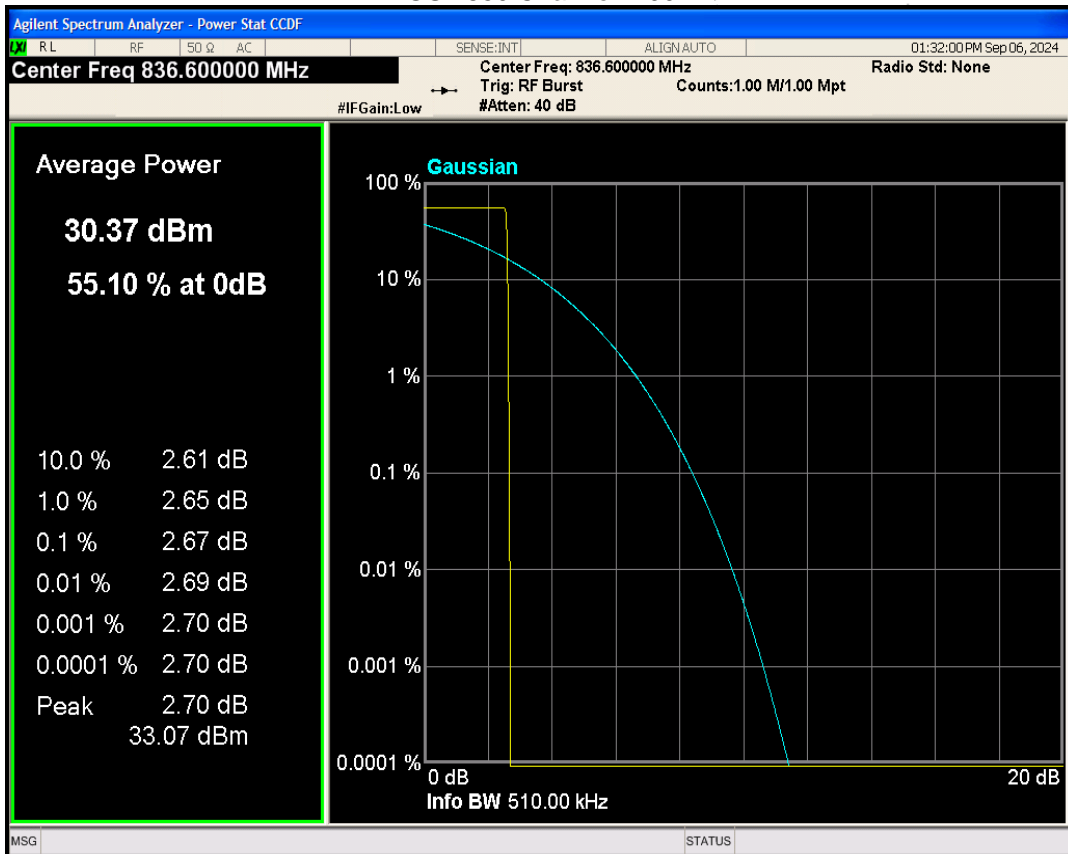

GSM850 Channel=251

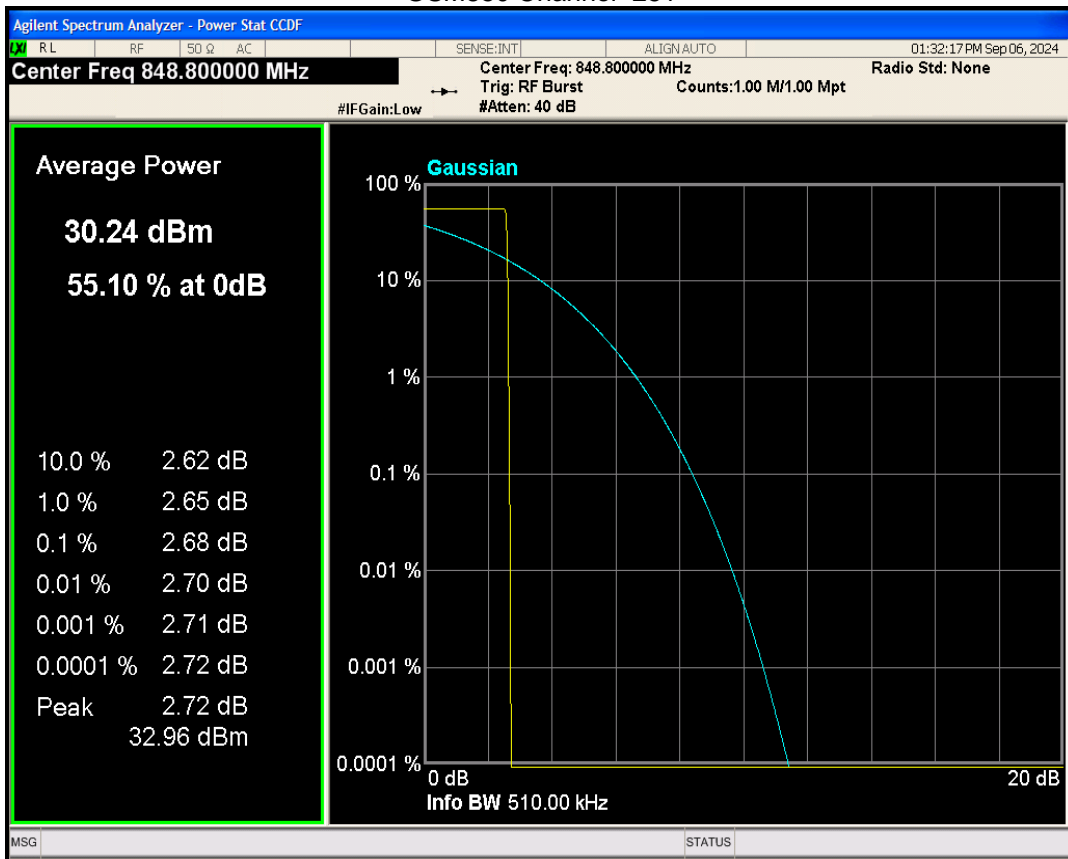

GPRS850 Channel=128

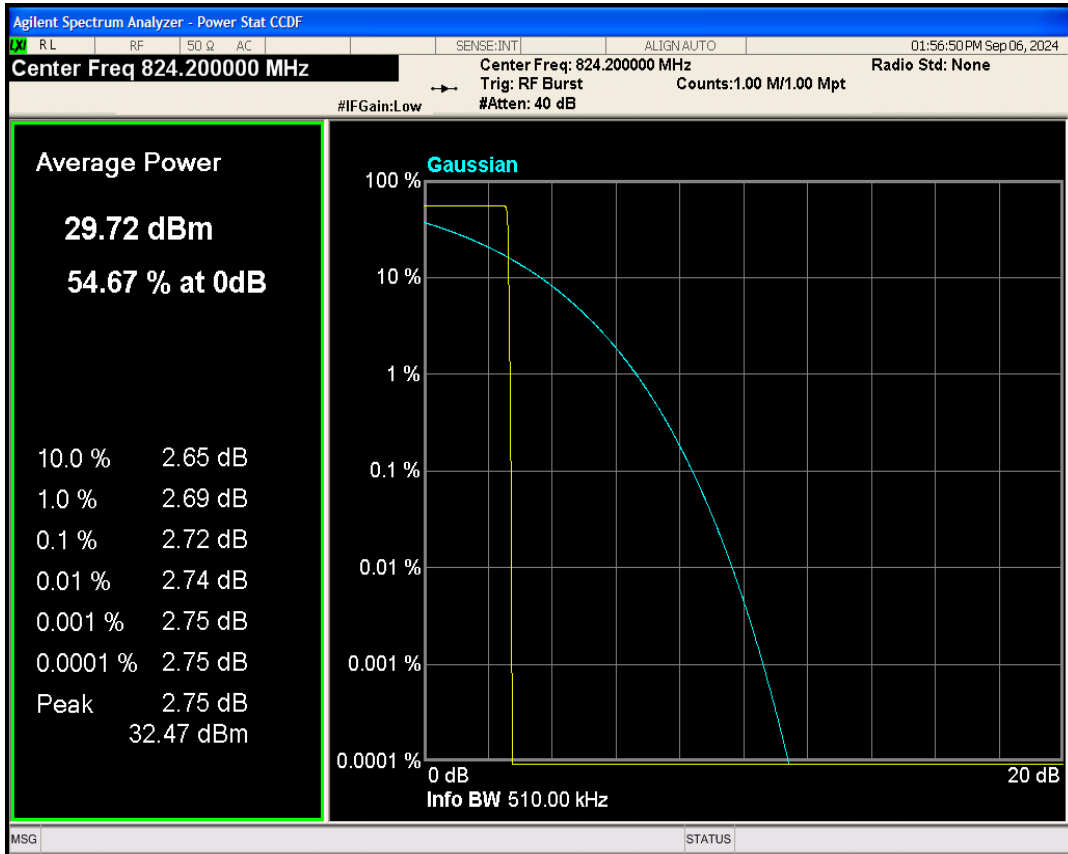

GPRS850 Channel=190

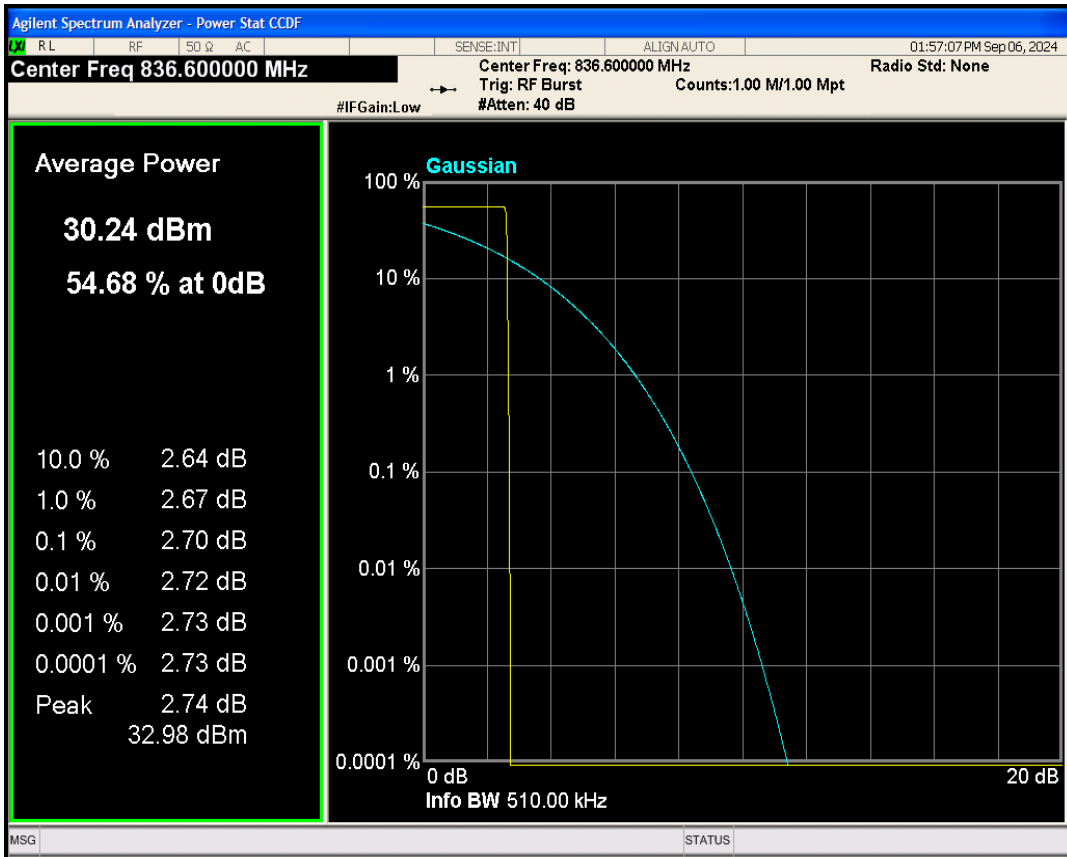

GPRS850 Channel=251

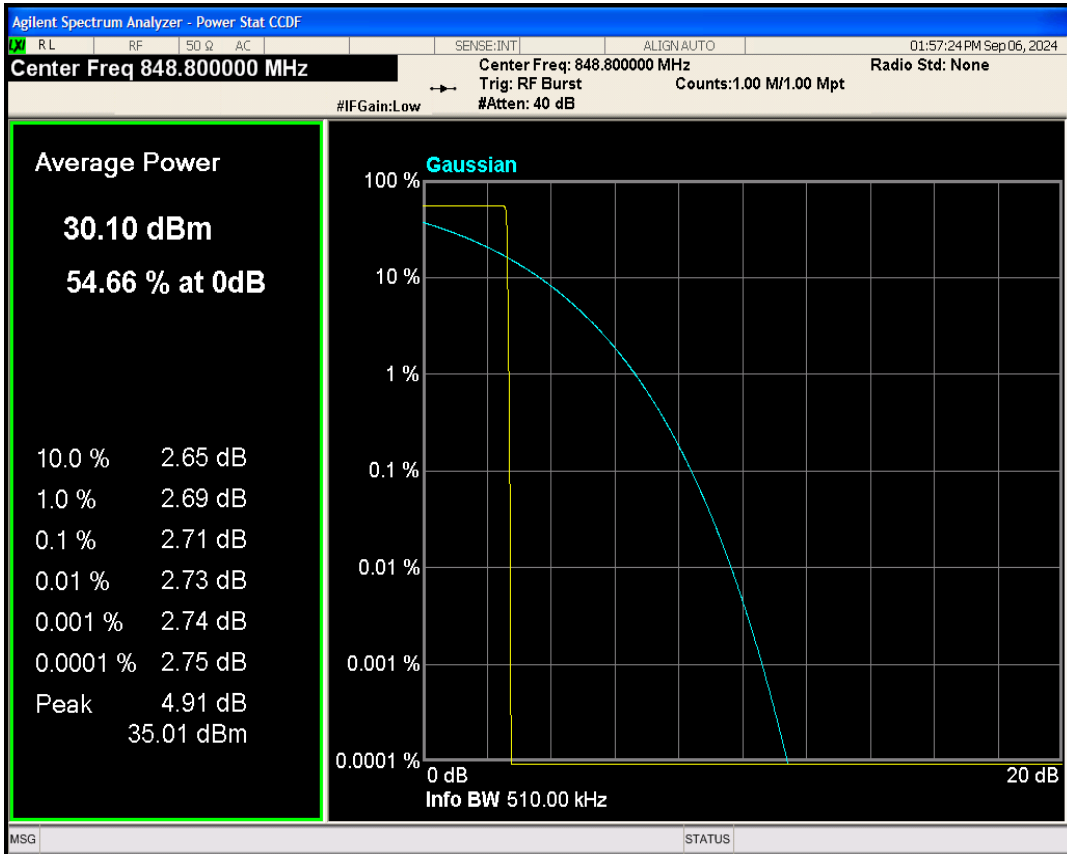

EGPRS850 Channel=128

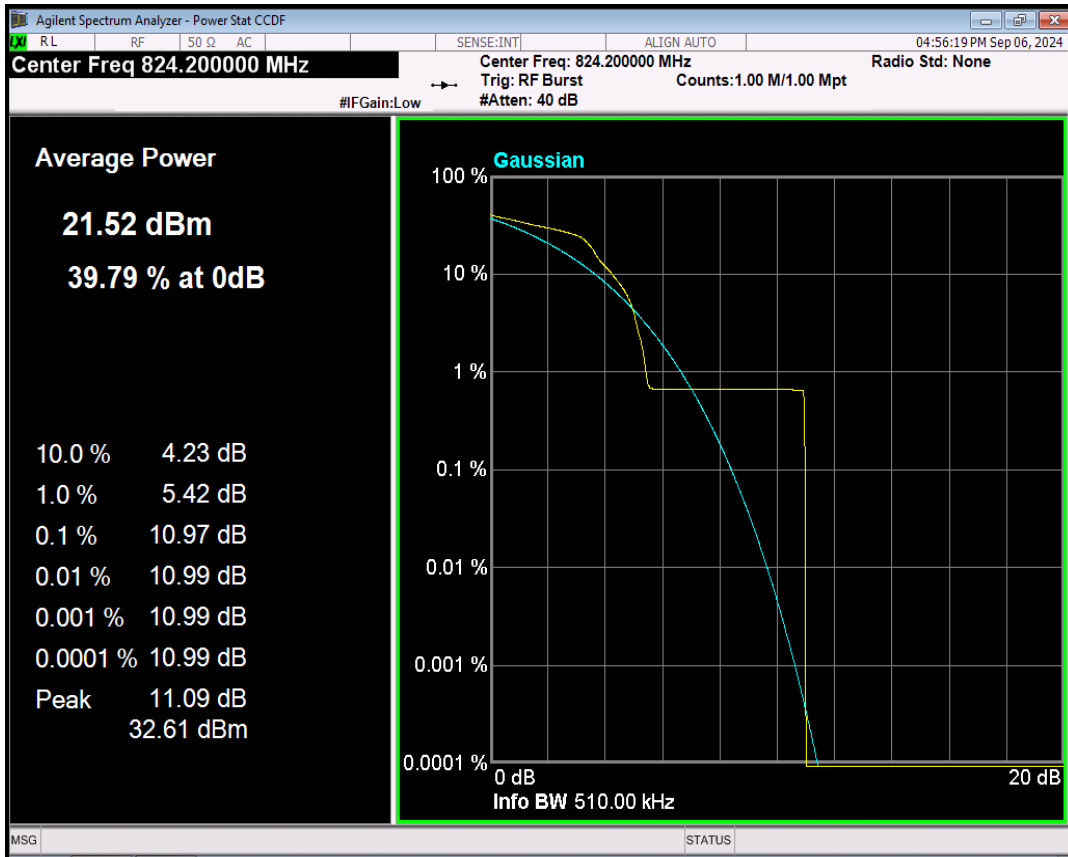

EGPRS850 Channel=190

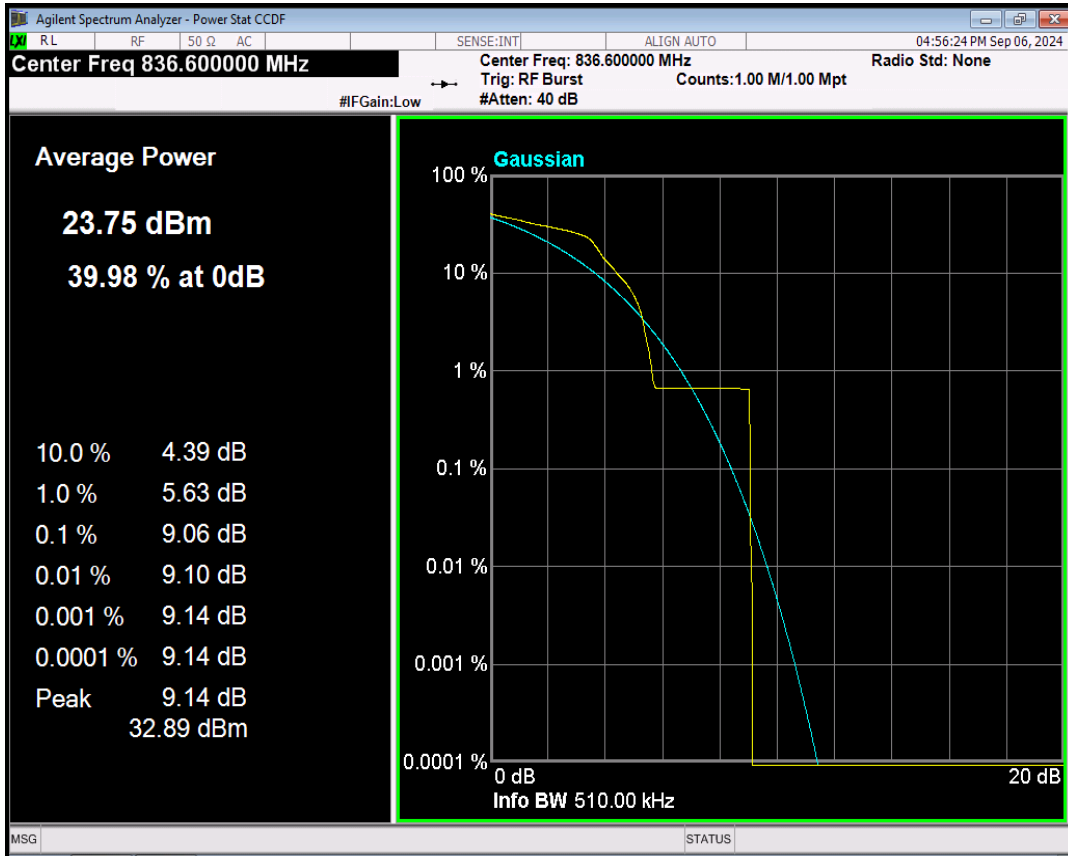

EGPRS850 Channel=251



Band	Channel	Frequency (MHz)	Result (dB)	high Limit (dB)	Verdict
GSM1900	512	1850.2	2.68	13.00	PASS
GSM1900	661	1880	2.66	13.00	PASS
GSM1900	810	1909.8	2.66	13.00	PASS
GPRS1900	512	1850.2	2.71	13.00	PASS
GPRS1900	661	1880	2.71	13.00	PASS
GPRS1900	810	1909.8	2.71	13.00	PASS
EGPRS1900	512	1850.2	5.90	13.00	PASS
EGPRS1900	661	1880	6.23	13.00	PASS
EGPRS1900	810	1909.8	5.85	13.00	PASS

GSM1900 Channel=512

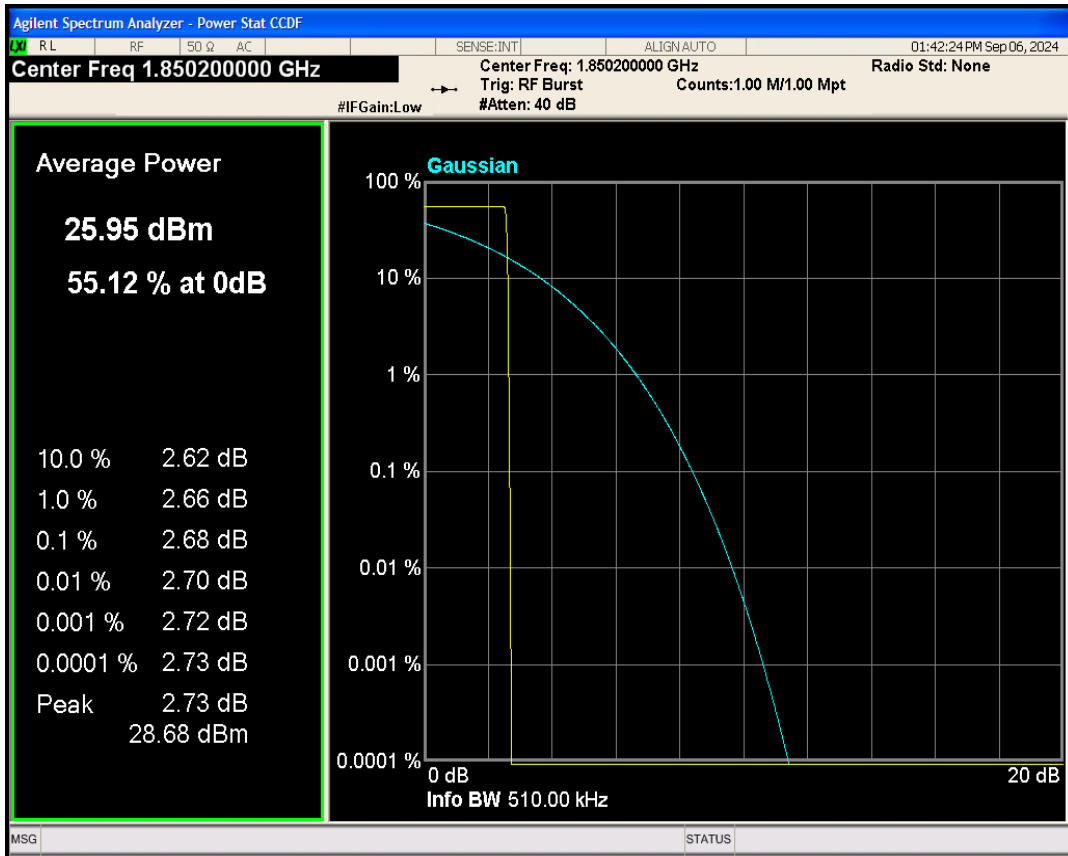

GSM1900 Channel=661

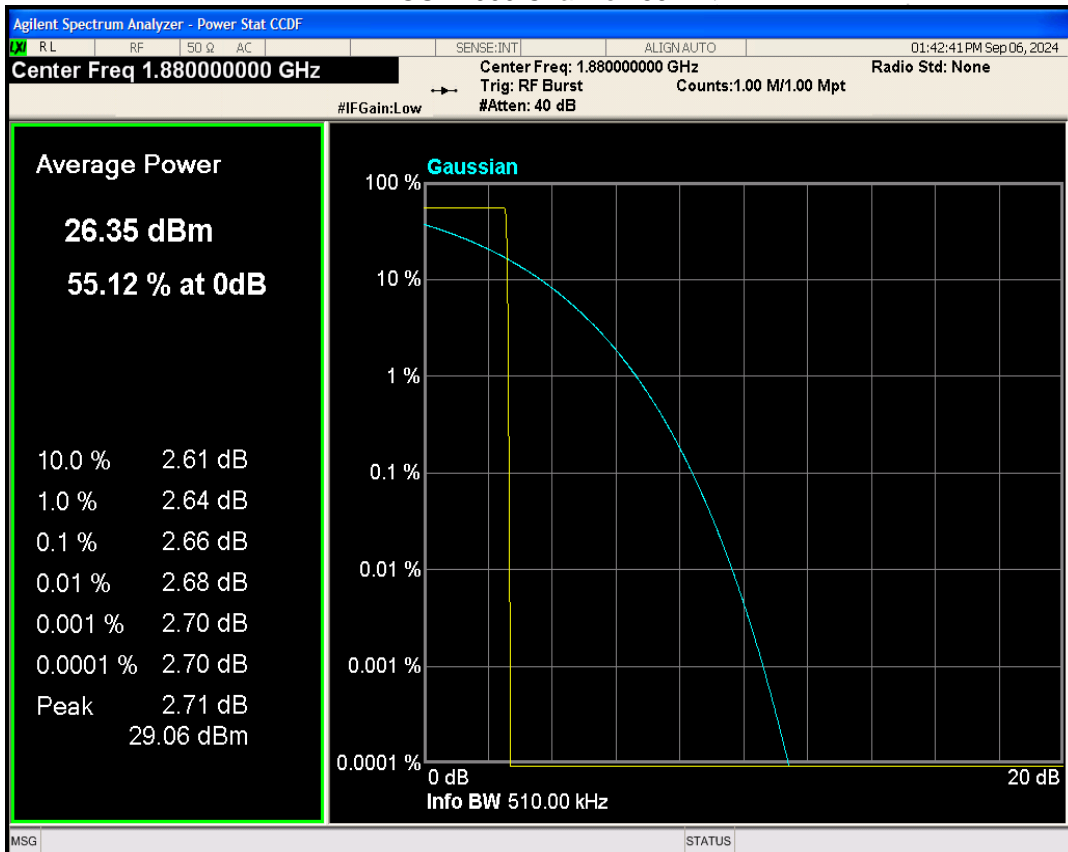

GSM1900 Channel=810

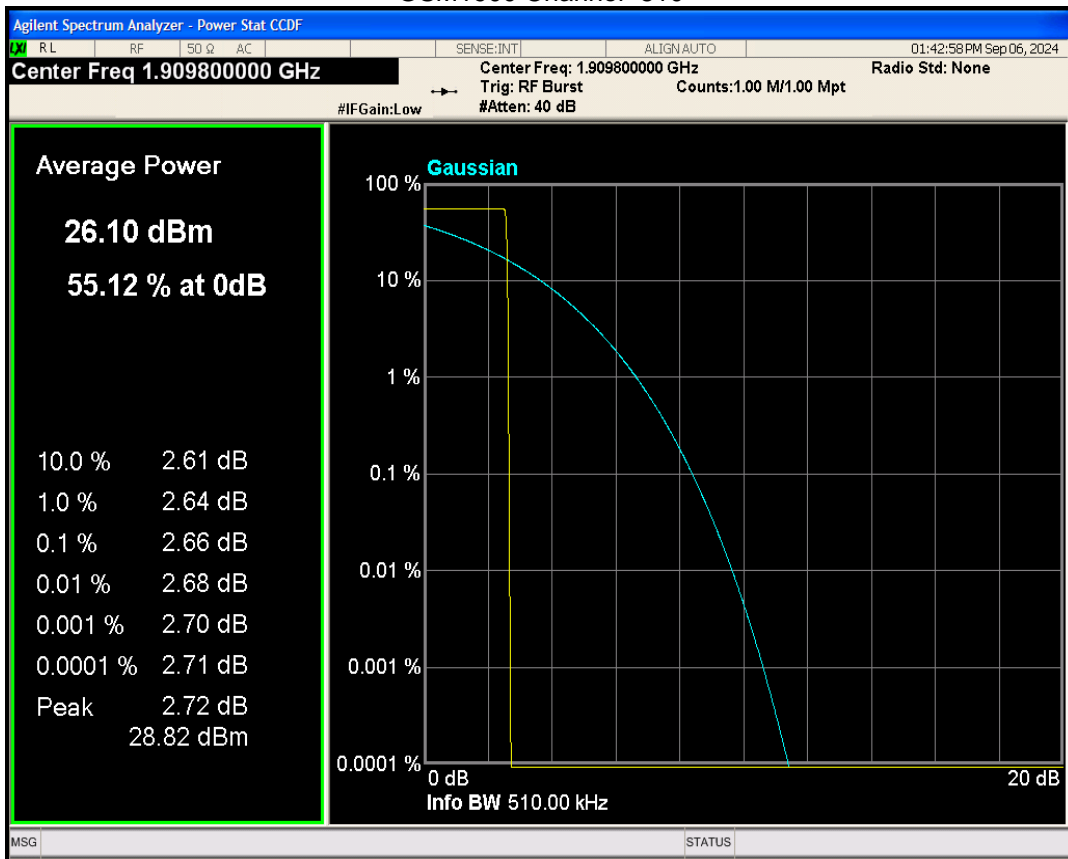

GPRS1900 Channel=512

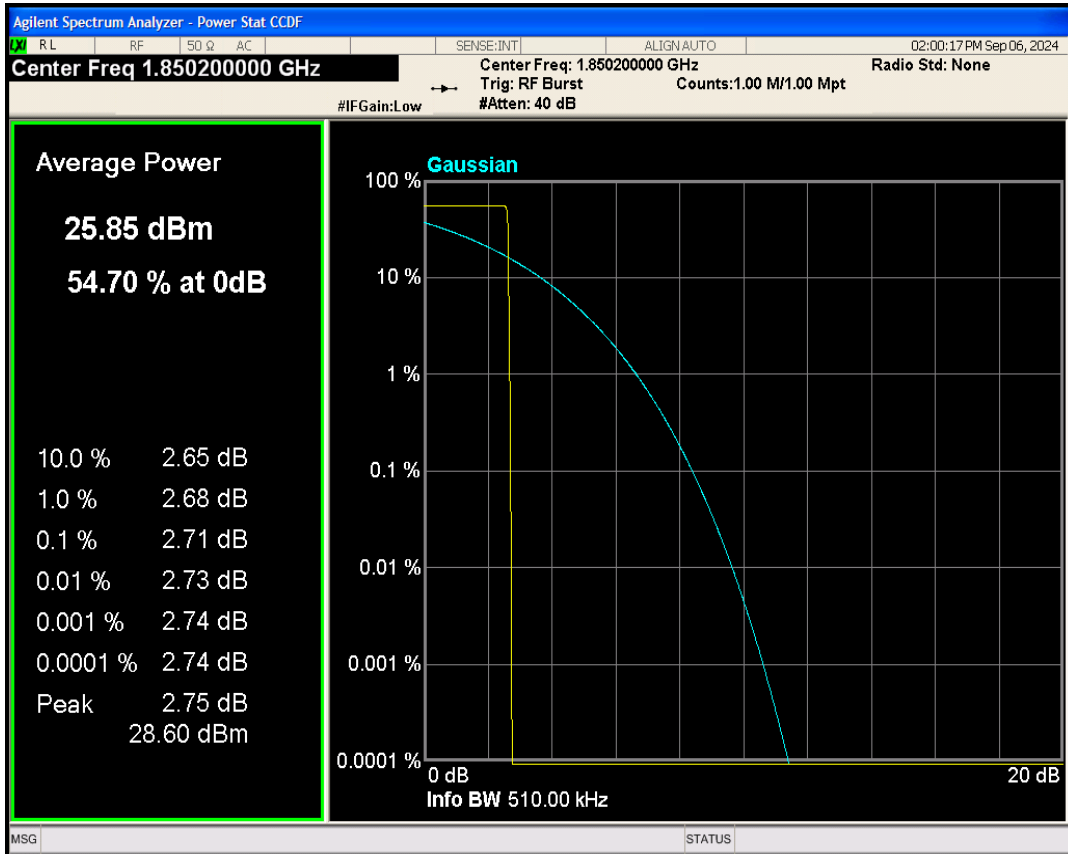

GPRS1900 Channel=661

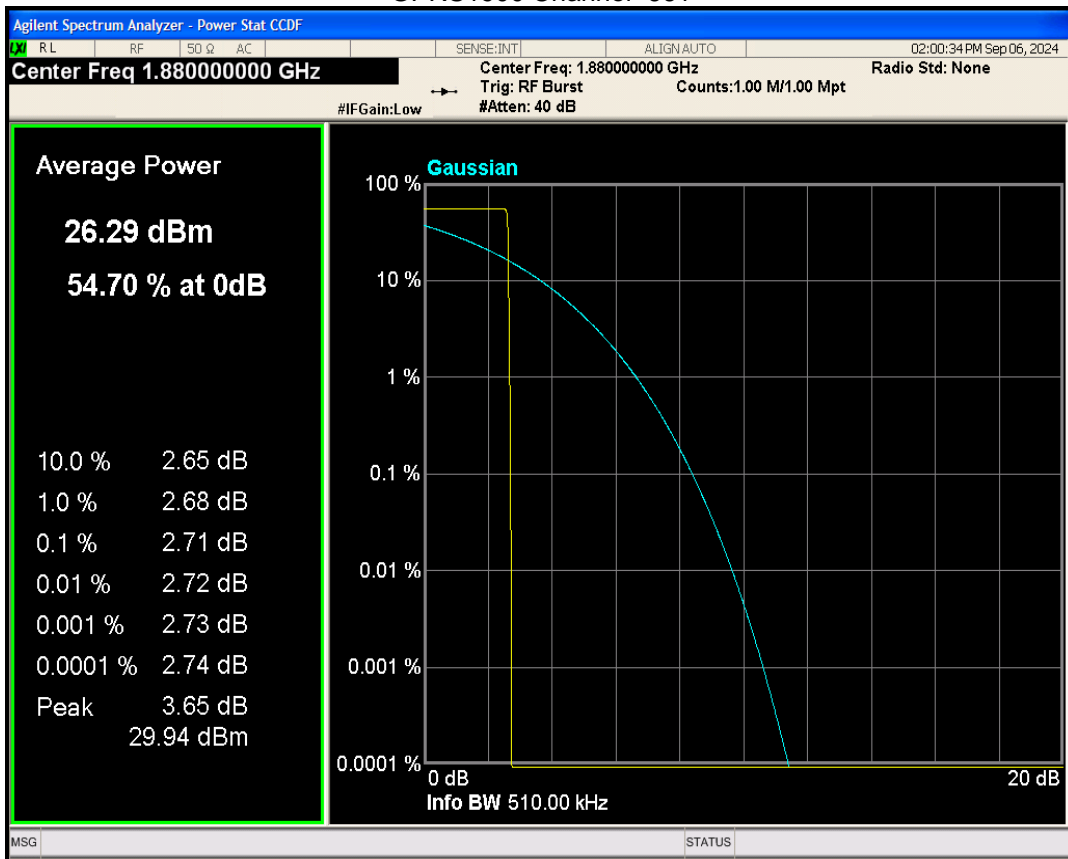

GPRS1900 Channel=810

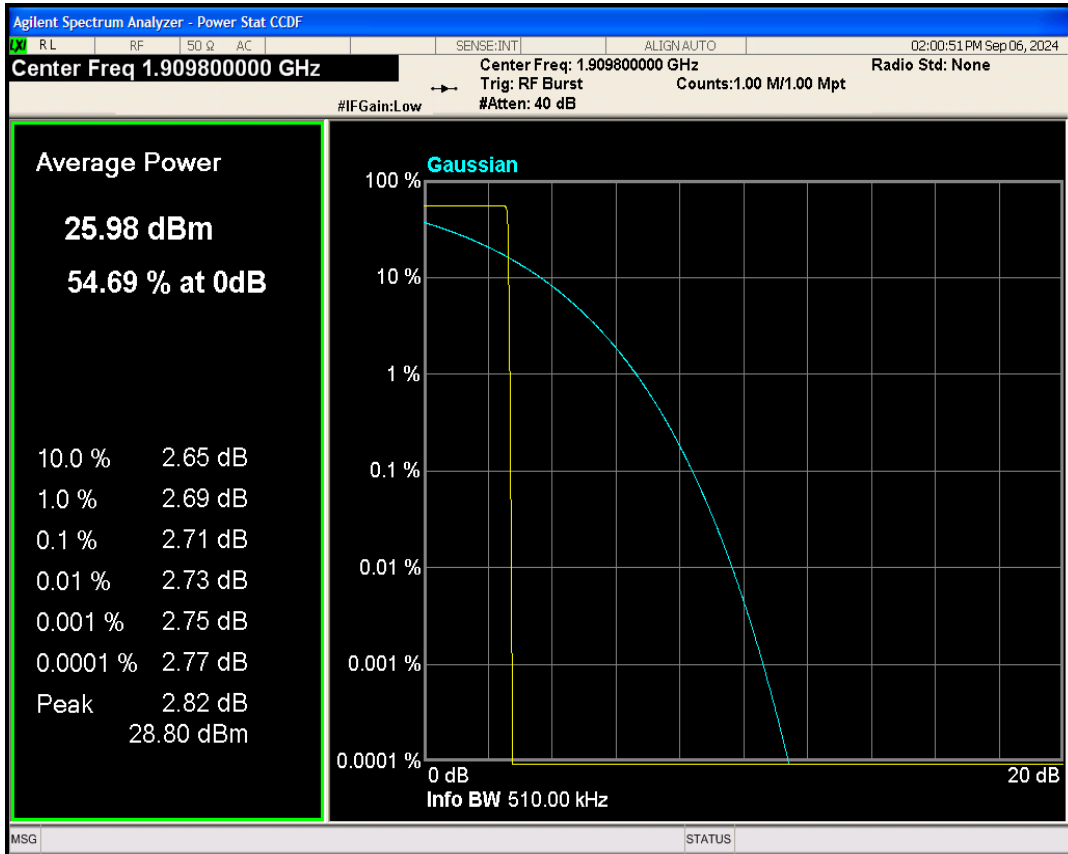

EGPRS1900 Channel=512

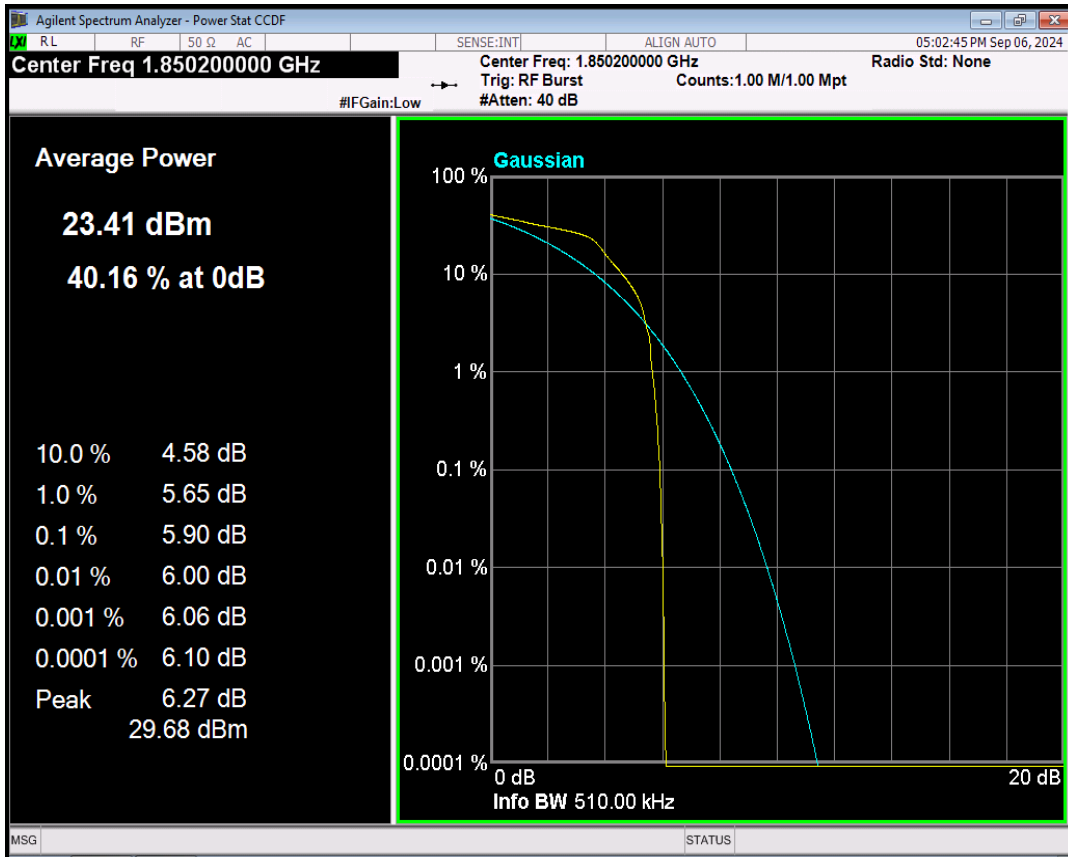

EGPRS1900 Channel=661

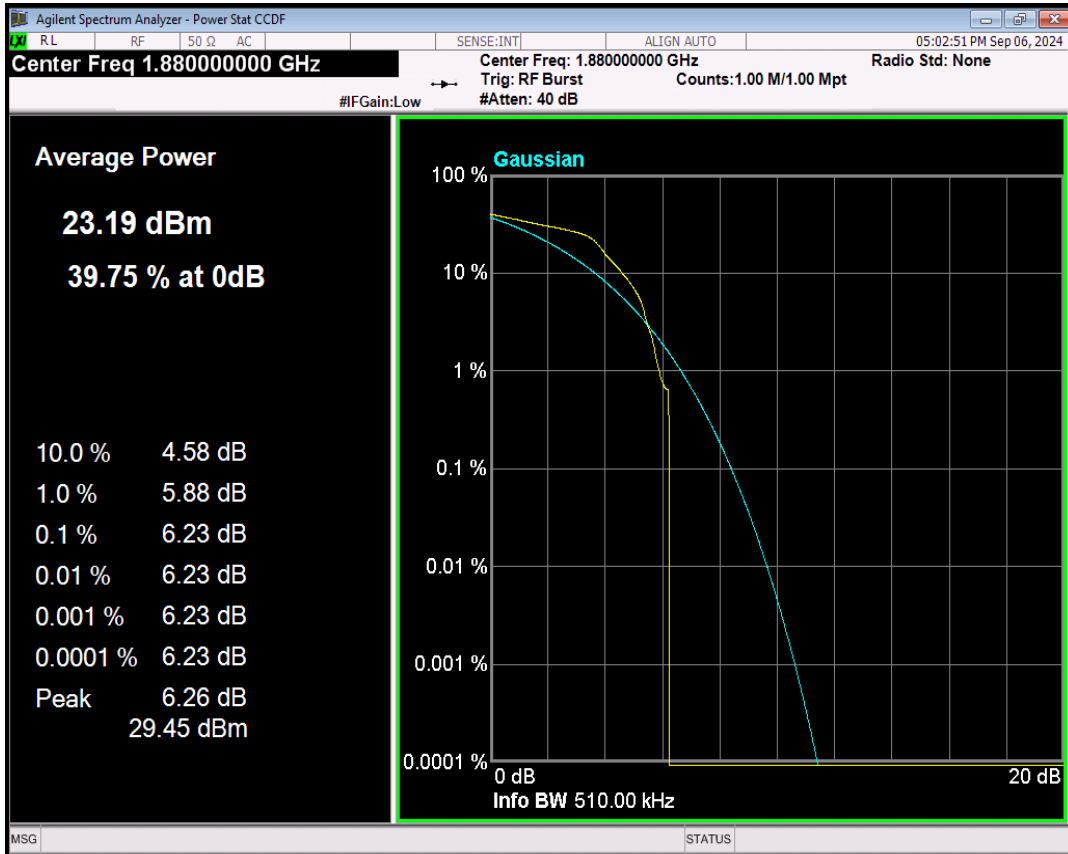

EGPRS1900 Channel=810

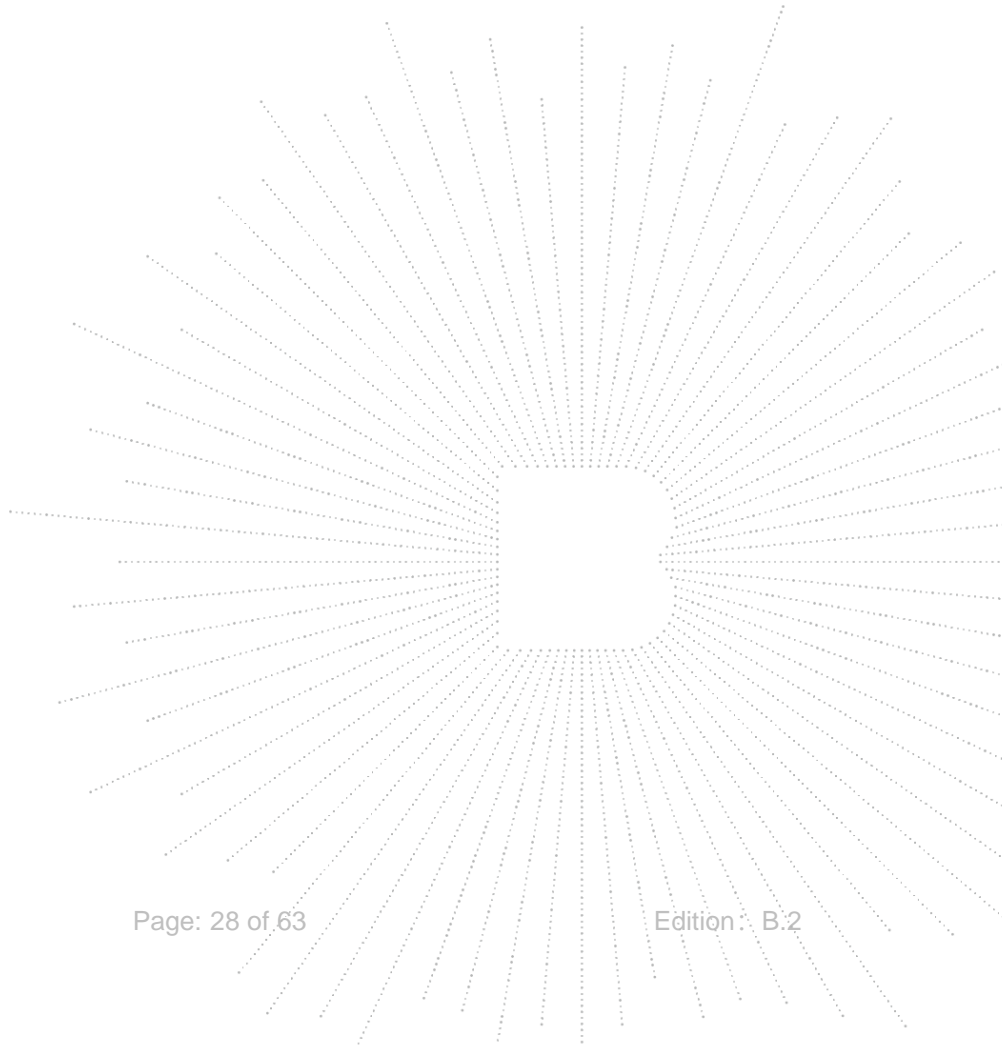
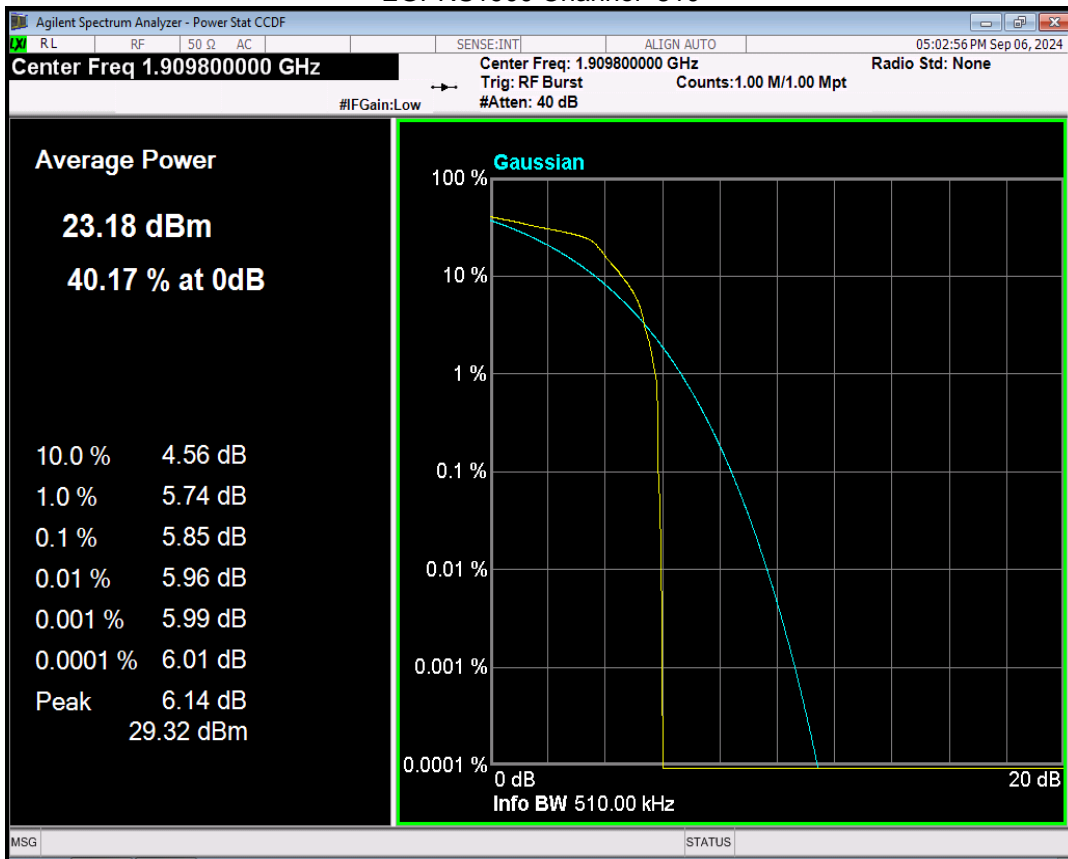

8. Emission Bandwidth

8.1 Block Diagram Of Test Setup

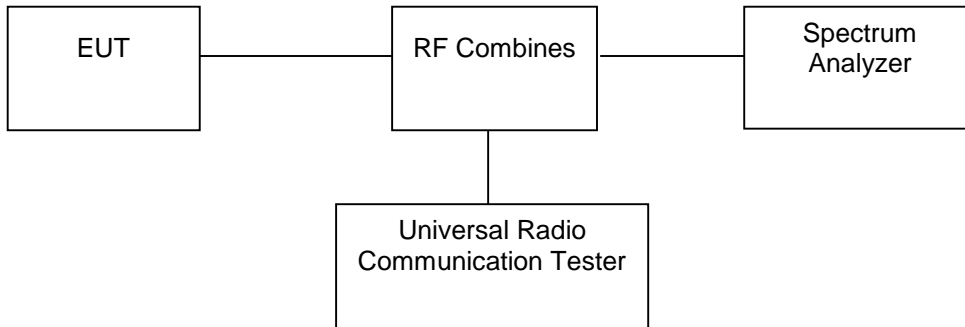

8.2 Limit

According to §22.917(b), The emission bandwidth is defined as the width of the signal between two points, one below the carrier center frequency and one above the carrier center frequency, outside of which all emissions are attenuated at least 26 dB below the transmitter power.

According to §24.238(b), The emission bandwidth is defined as the width of the signal between two points, one below the carrier center frequency and one above the carrier center frequency, outside of which all emissions are attenuated at least 26 dB below the transmitter power.

According to §27.53, The emission bandwidth is defined as the width of the signal between two points, one below the carrier center frequency and one above the carrier center frequency, outside of which all emissions are attenuated at least 26 dB below the transmitter power.

8.3 Test procedure

The RF output terminal of the transmitter was connected to the input of the spectrum analyzer via a suitable attenuation. The RBW of the spectrum analyzer was set to 10kHz for GSM mode and 100kHz for WCDMA mode, VBW shall be at least 3 times the RBW, and the 26dB bandwidth was recorded.

8.4 Test Result

Band	Channel	Frequency (MHz)	99% OBW (kHz)	-26dB EBW (kHz)	Verdict
GSM850	128	824.2	247.405	317.123	PASS
GSM850	190	836.6	243.230	312.357	PASS
GSM850	251	848.8	245.132	314.834	PASS
GPRS850	128	824.2	253.981	319.182	PASS
GPRS850	190	836.6	243.537	312.909	PASS
GPRS850	251	848.8	245.129	321.234	PASS
EGPRS850	128	824.2	251.602	298.237	PASS
EGPRS850	190	836.6	246.930	298.142	PASS
EGPRS850	251	848.8	242.032	297.629	PASS

GSM850 Channel=128

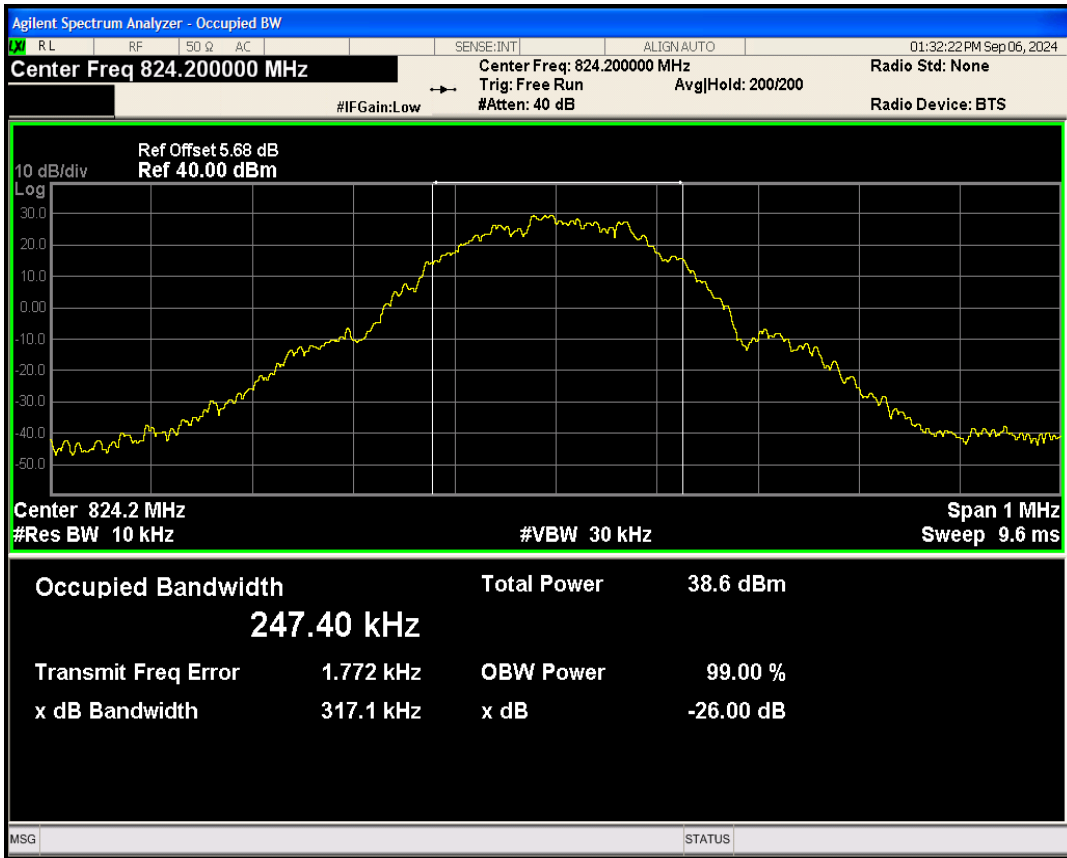

GSM850 Channel=190

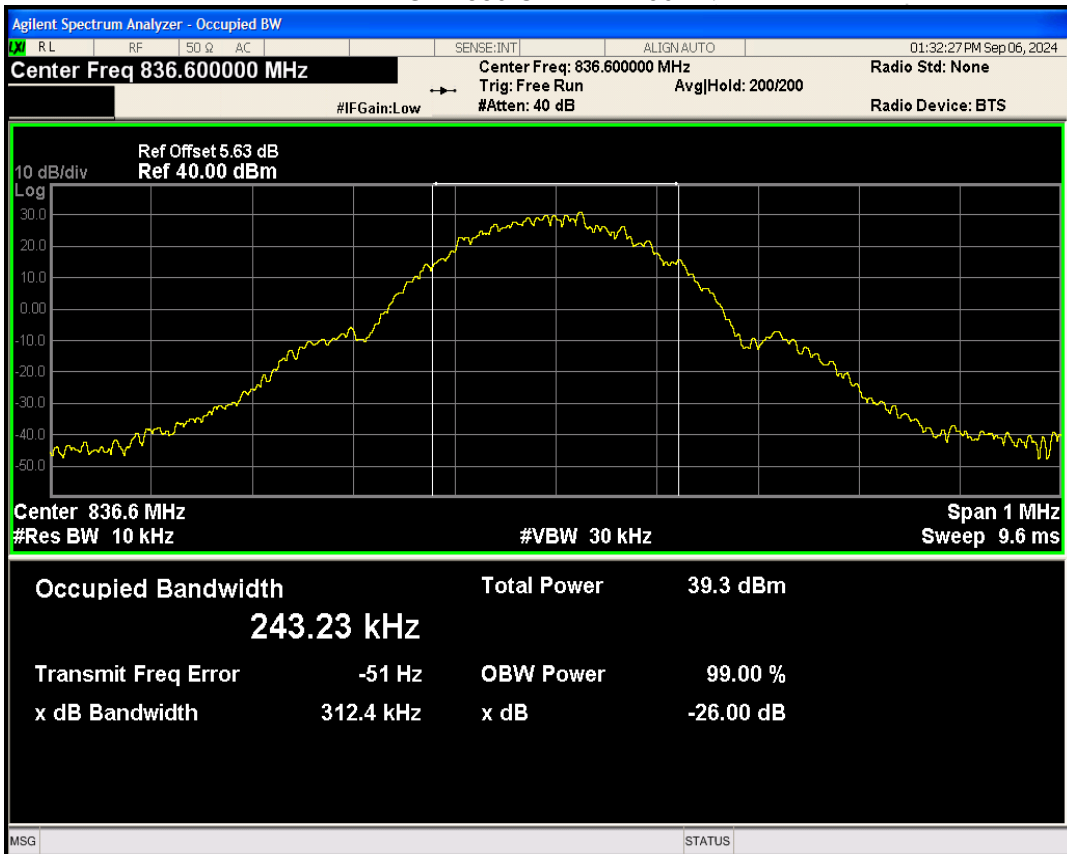

GSM850 Channel=251

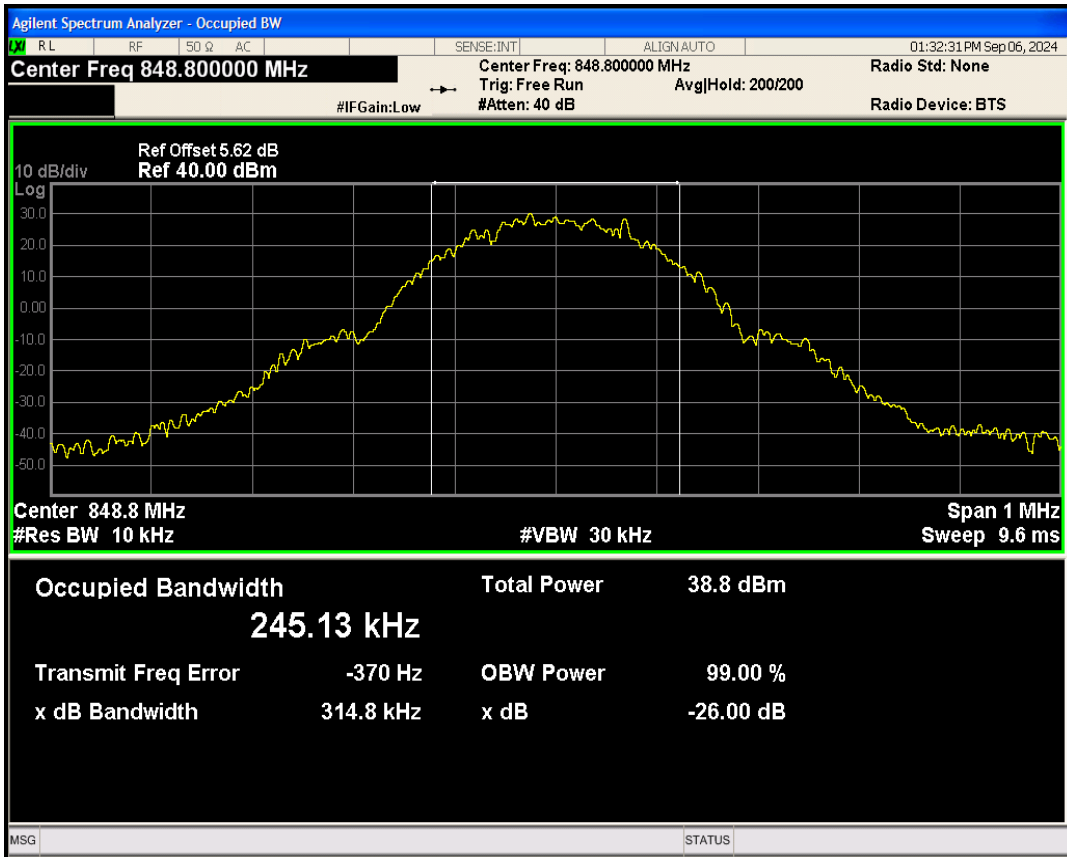

GPRS850 Channel=128

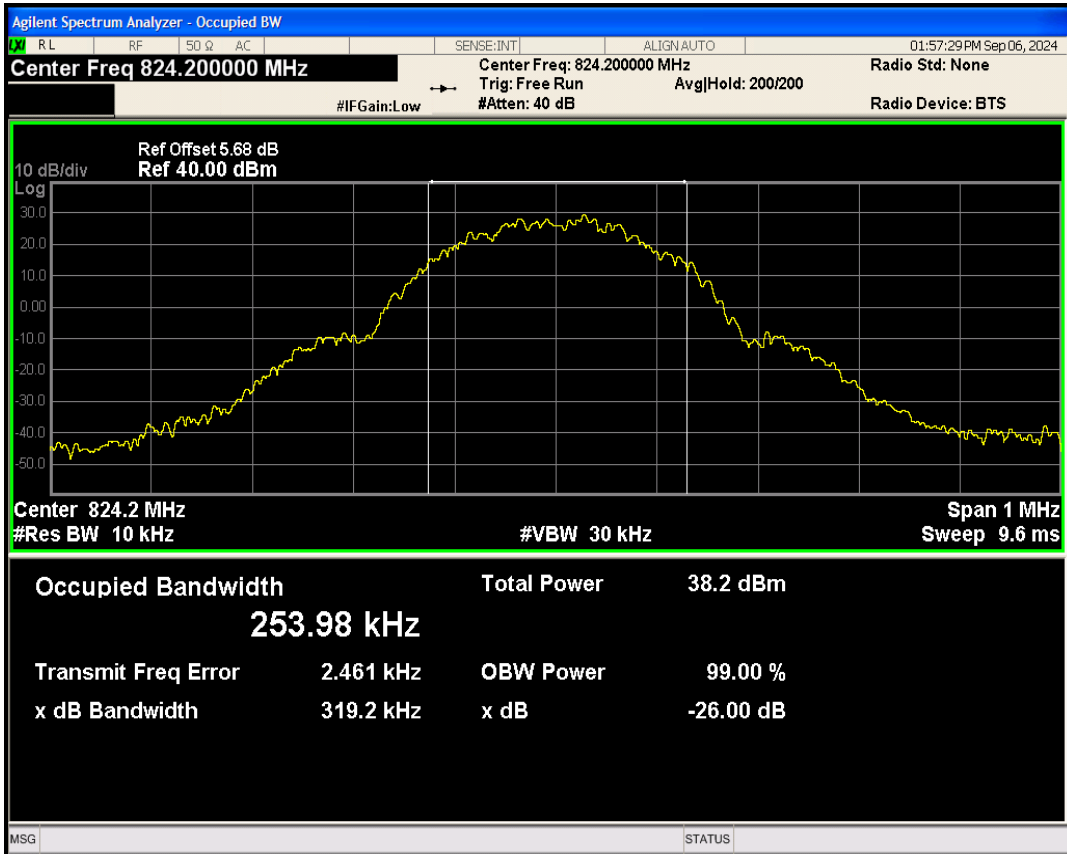

GPRS850 Channel=190

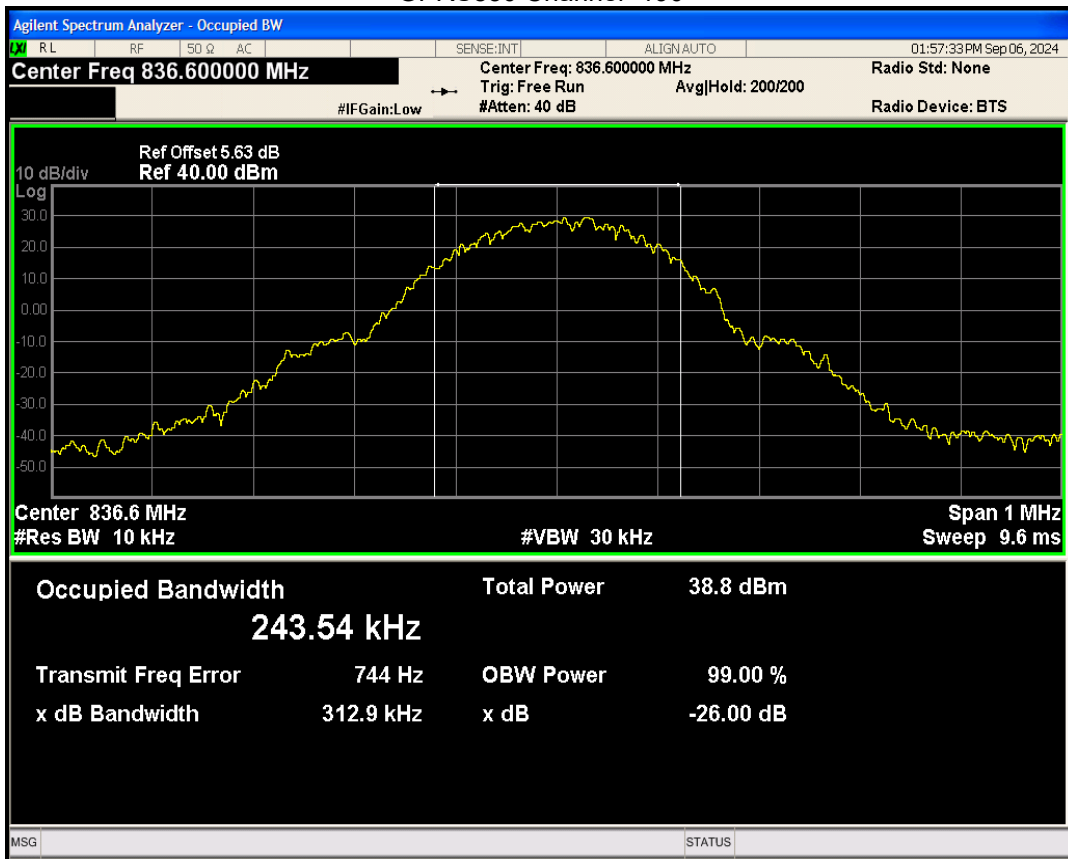

GPRS850 Channel=251

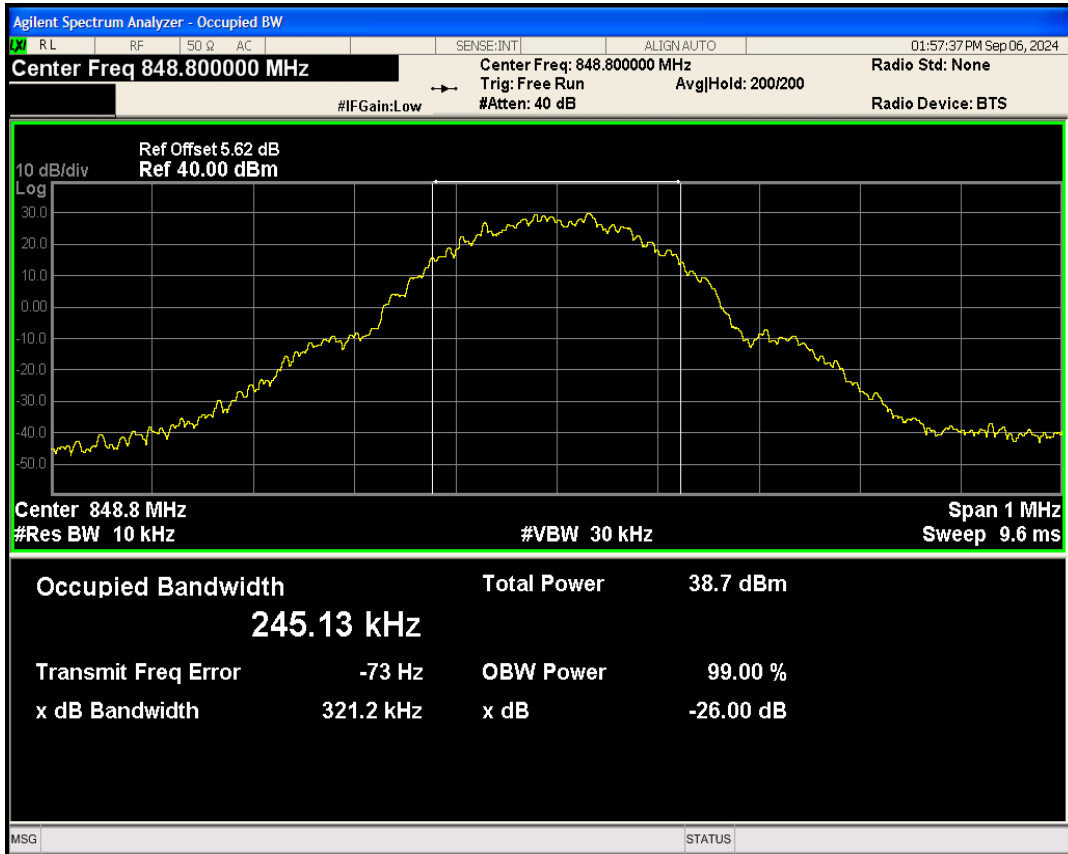

EGPRS850 Channel=128

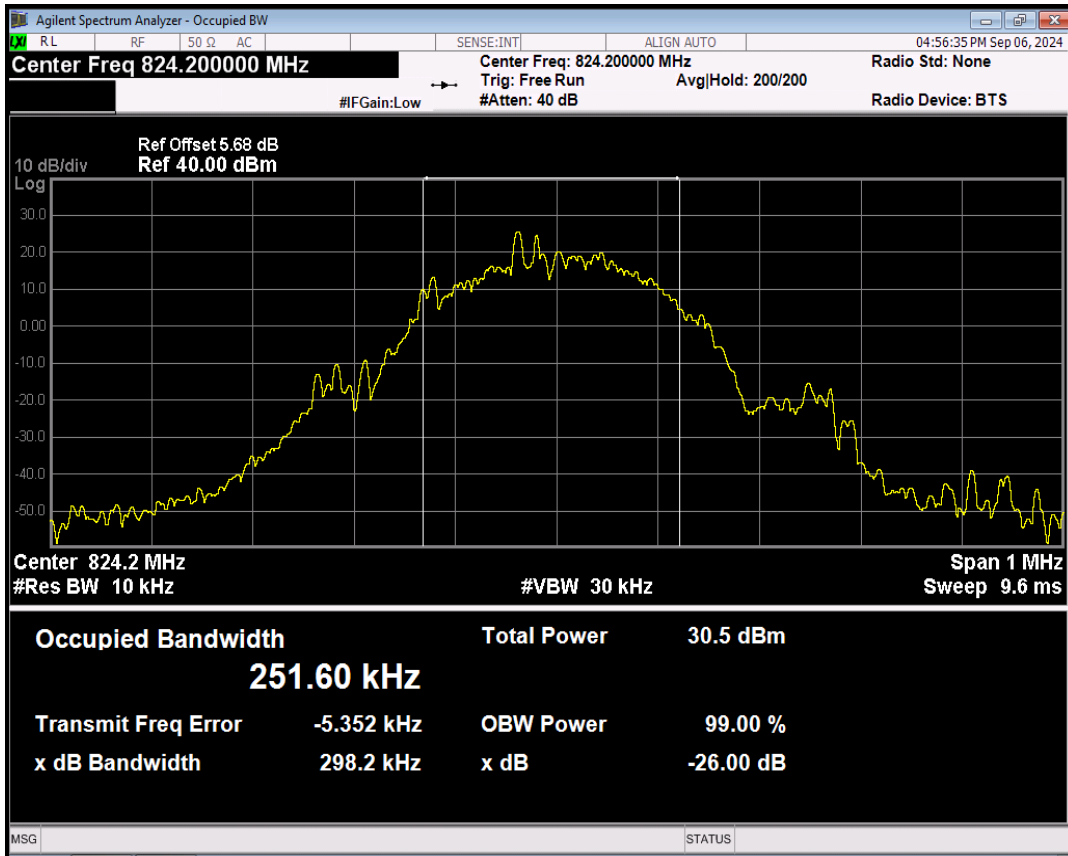

EGPRS850 Channel=190

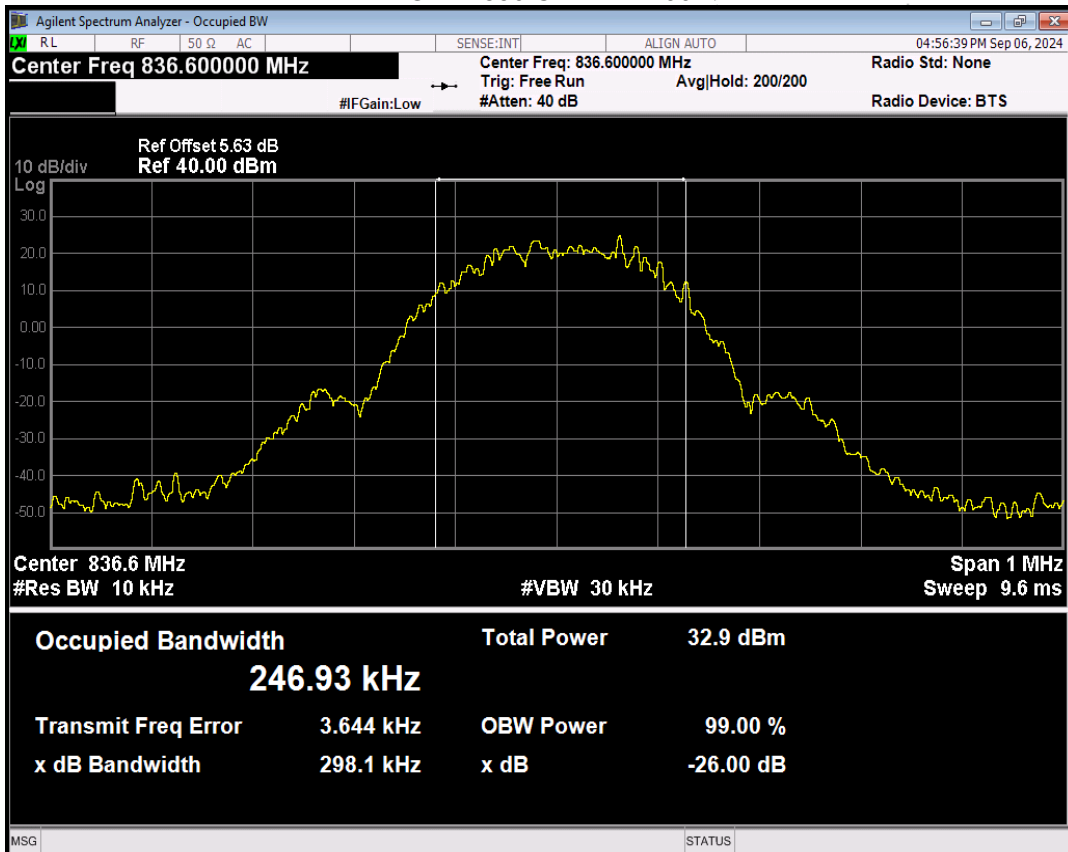

EGPRS850 Channel=251

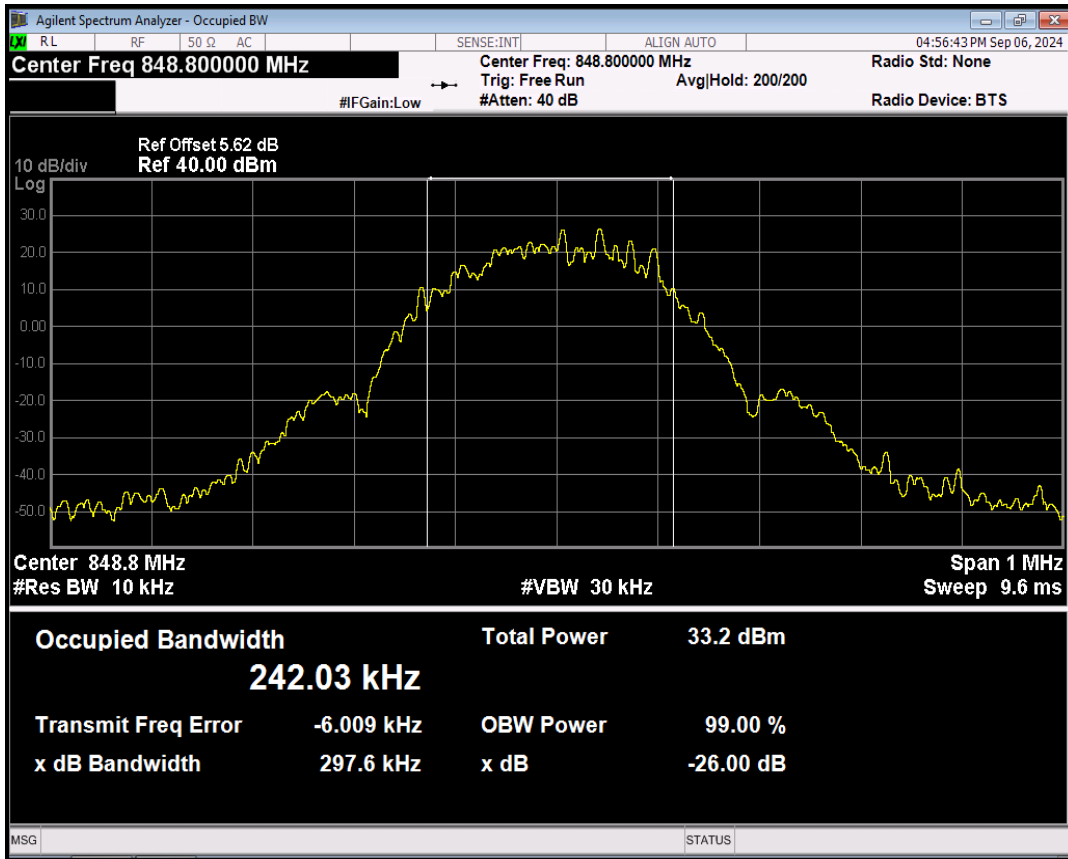

Band	Channel	Frequency (MHz)	99% OBW (kHz)	-26dB EBW (kHz)	Verdict
GSM1900	512	1850.2	245.490	318.729	PASS
GSM1900	661	1880	246.069	307.655	PASS
GSM1900	810	1909.8	248.389	320.297	PASS
GPRS1900	512	1850.2	248.548	317.798	PASS
GPRS1900	661	1880	248.130	310.501	PASS
GPRS1900	810	1909.8	248.665	317.877	PASS
EGPRS1900	512	1850.2	244.506	304.981	PASS
EGPRS1900	661	1880	244.397	302.678	PASS
EGPRS1900	810	1909.8	243.856	303.858	PASS

GSM1900 Channel=512

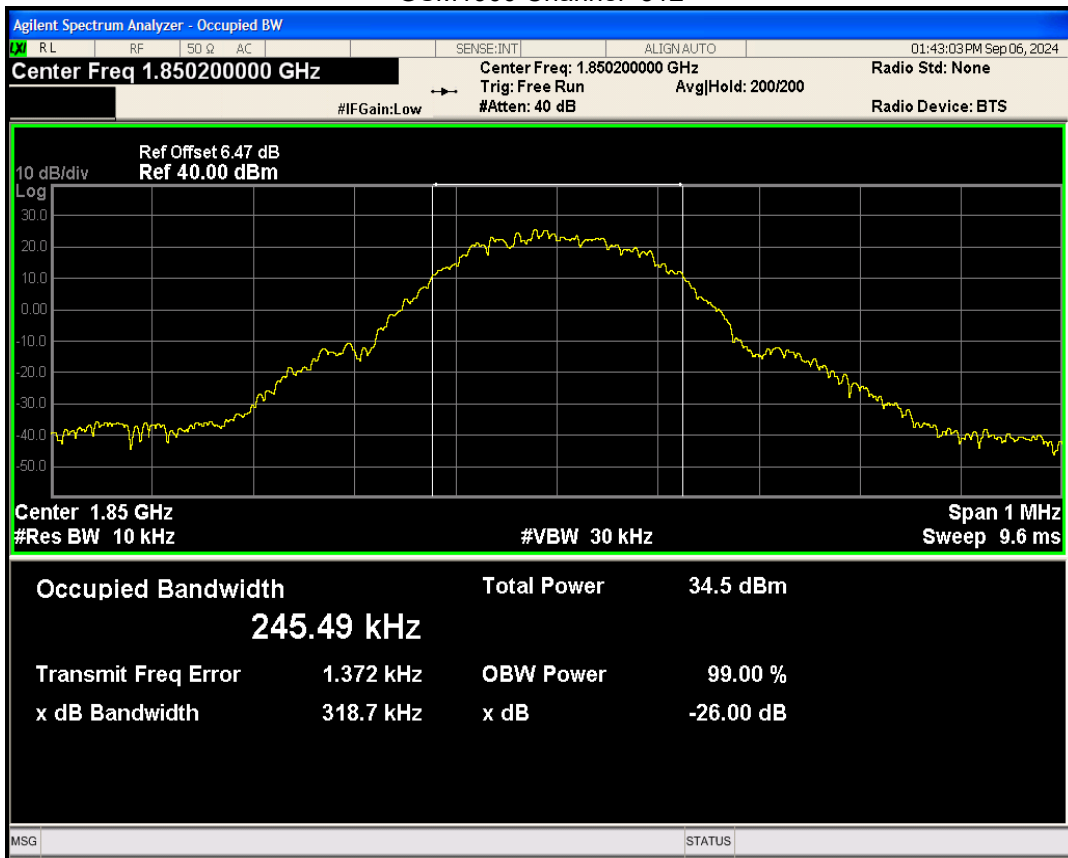

GSM1900 Channel=661

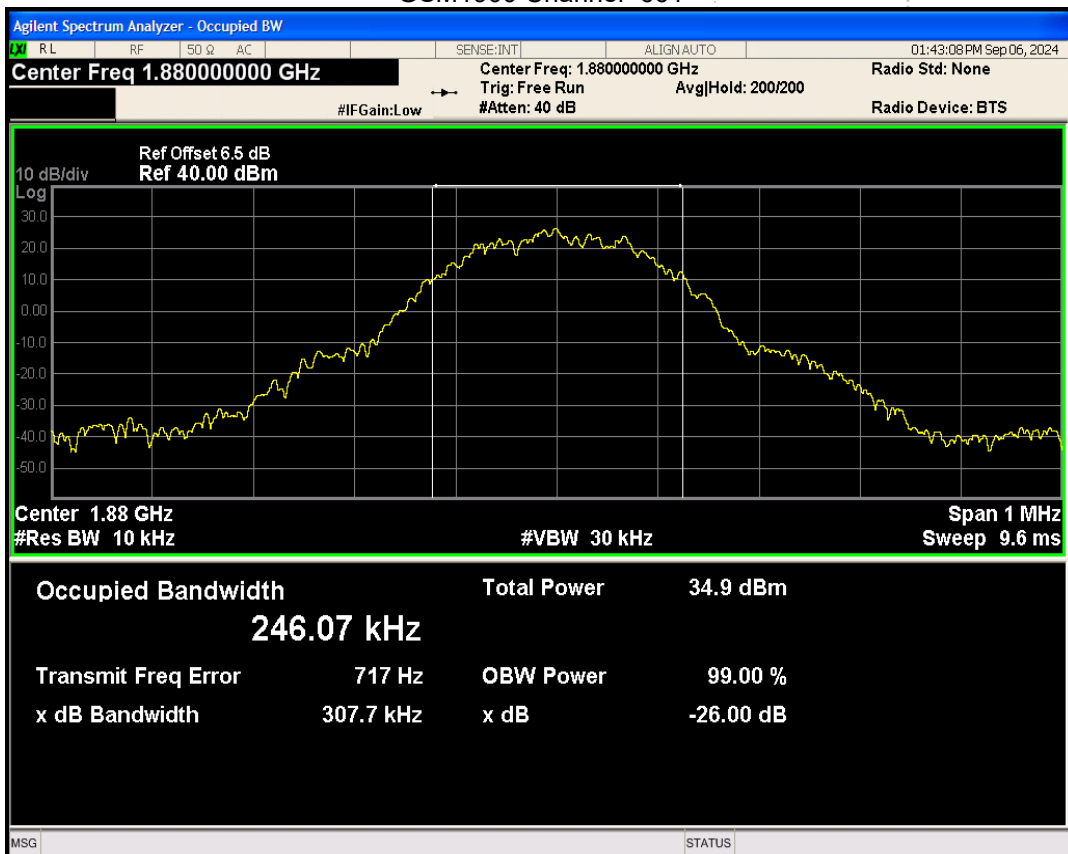

GSM1900 Channel=810

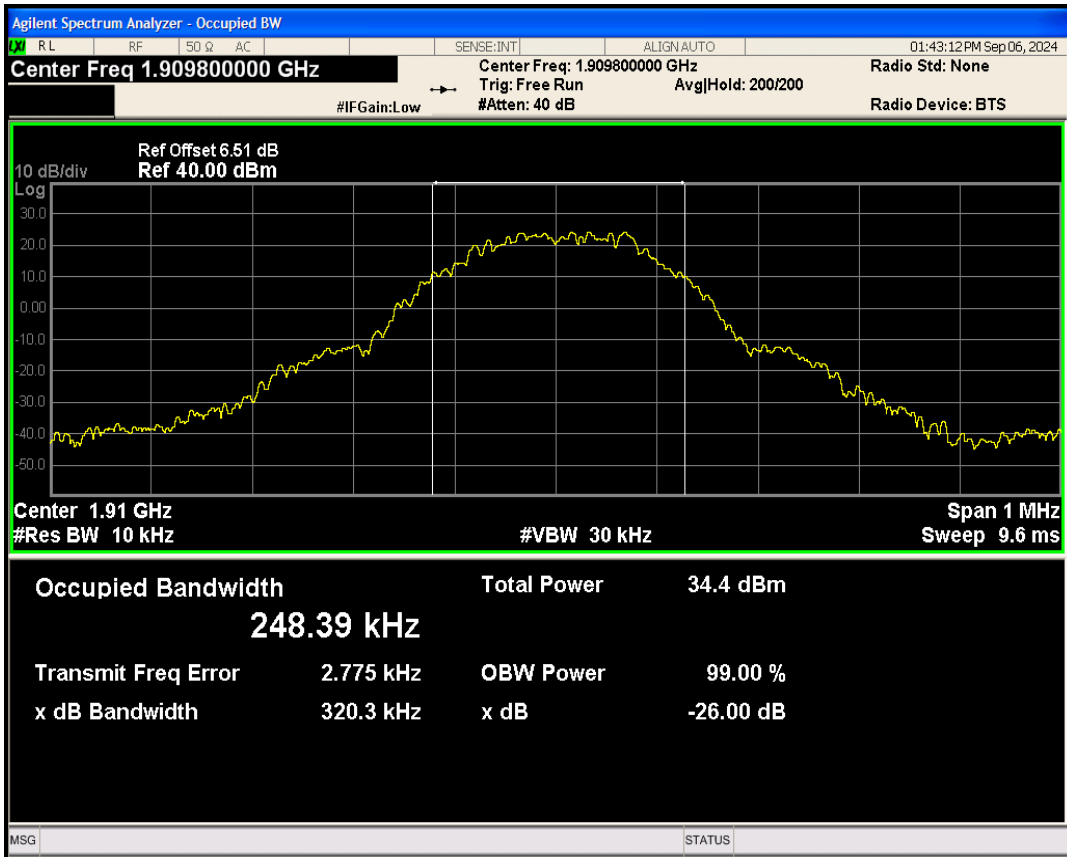

GPRS1900 Channel=512

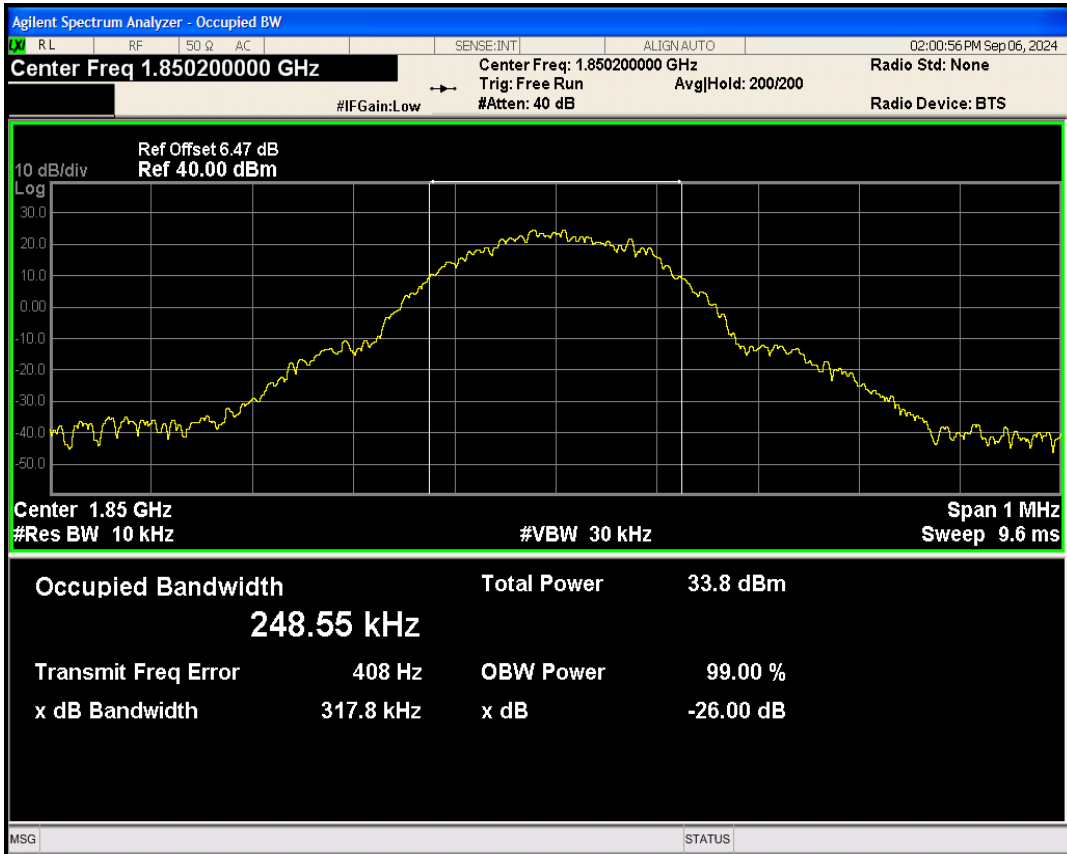

GPRS1900 Channel=661

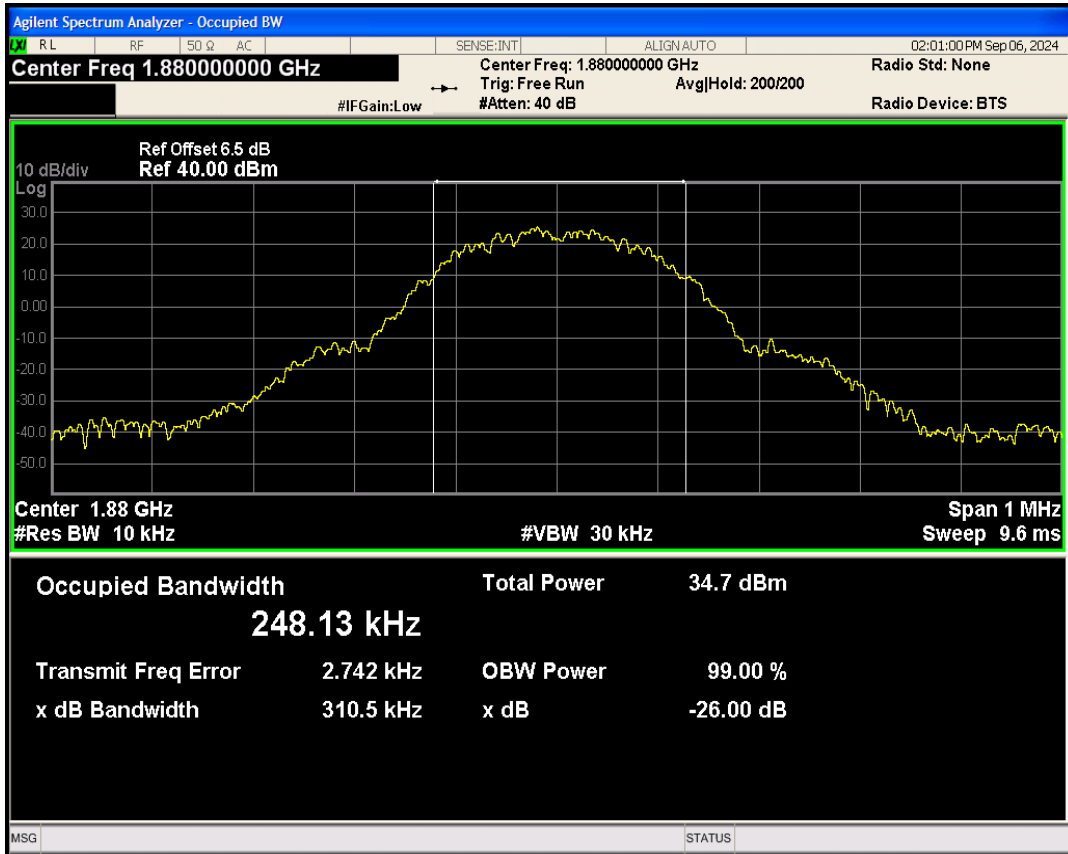
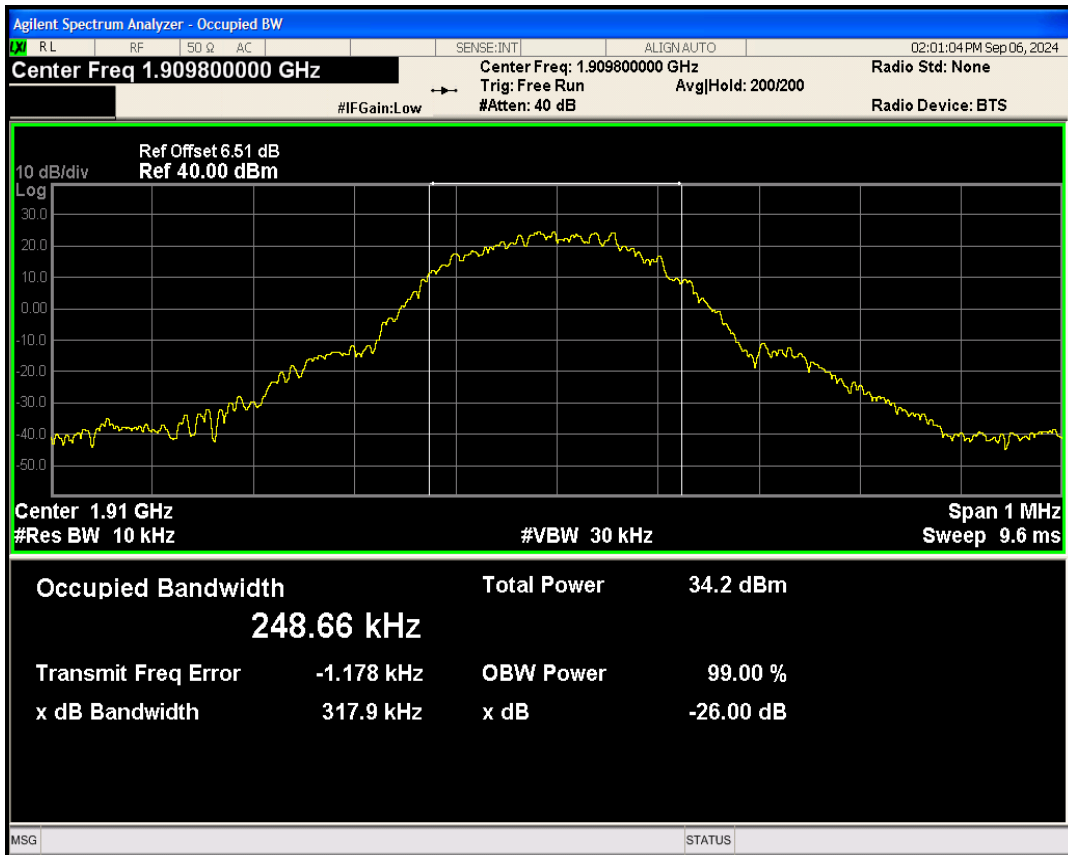
GPRS1900 Channel=810

EGPRS1900 Channel=512

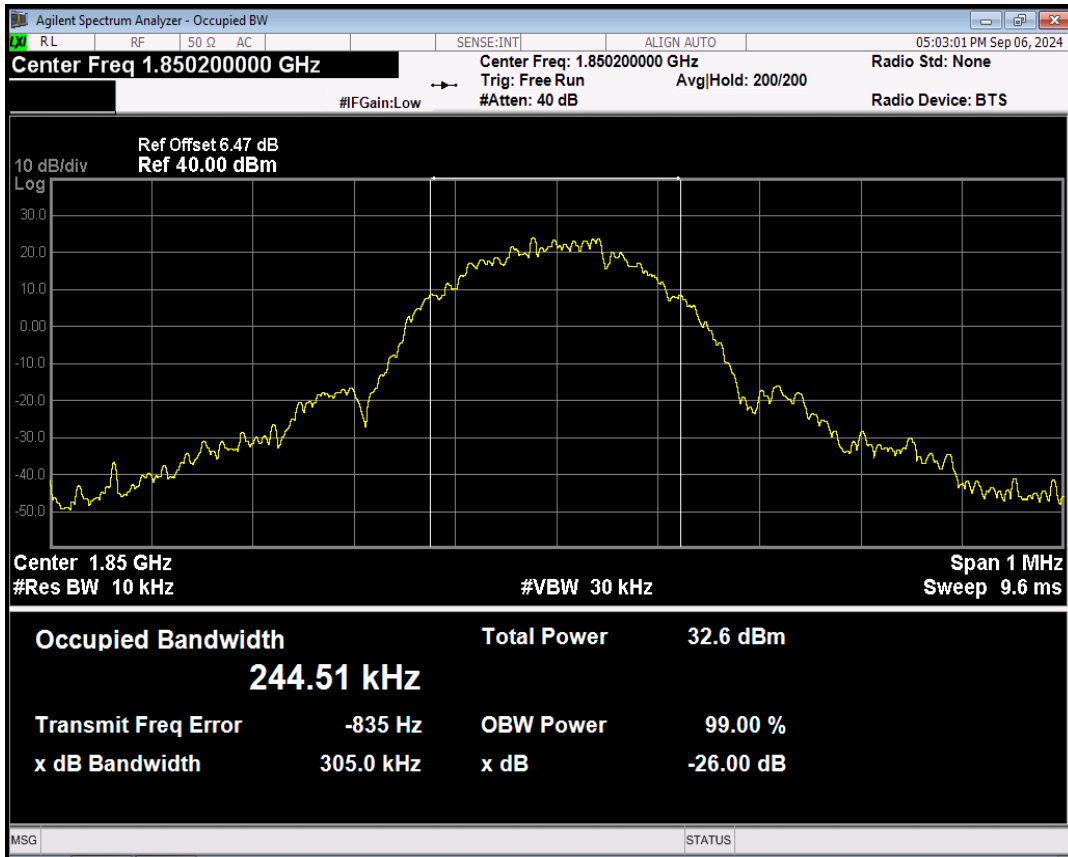

EGPRS1900 Channel=661

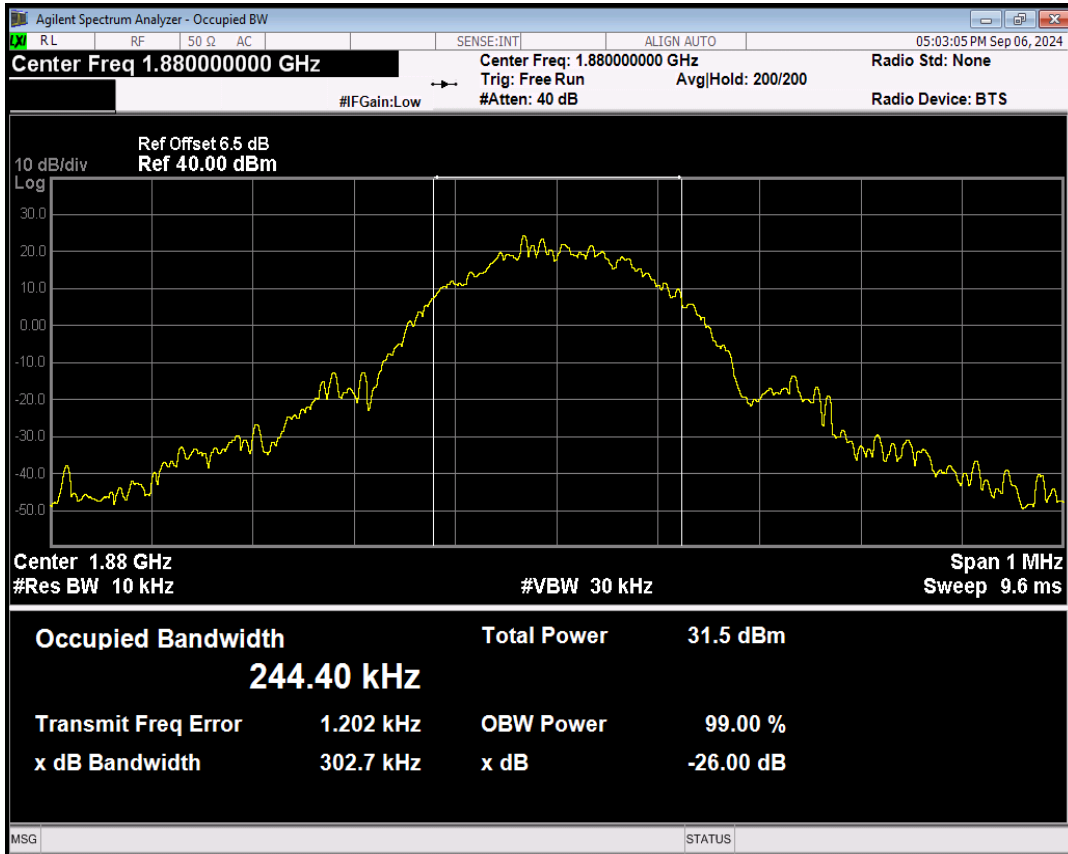

EGPRS1900 Channel=810

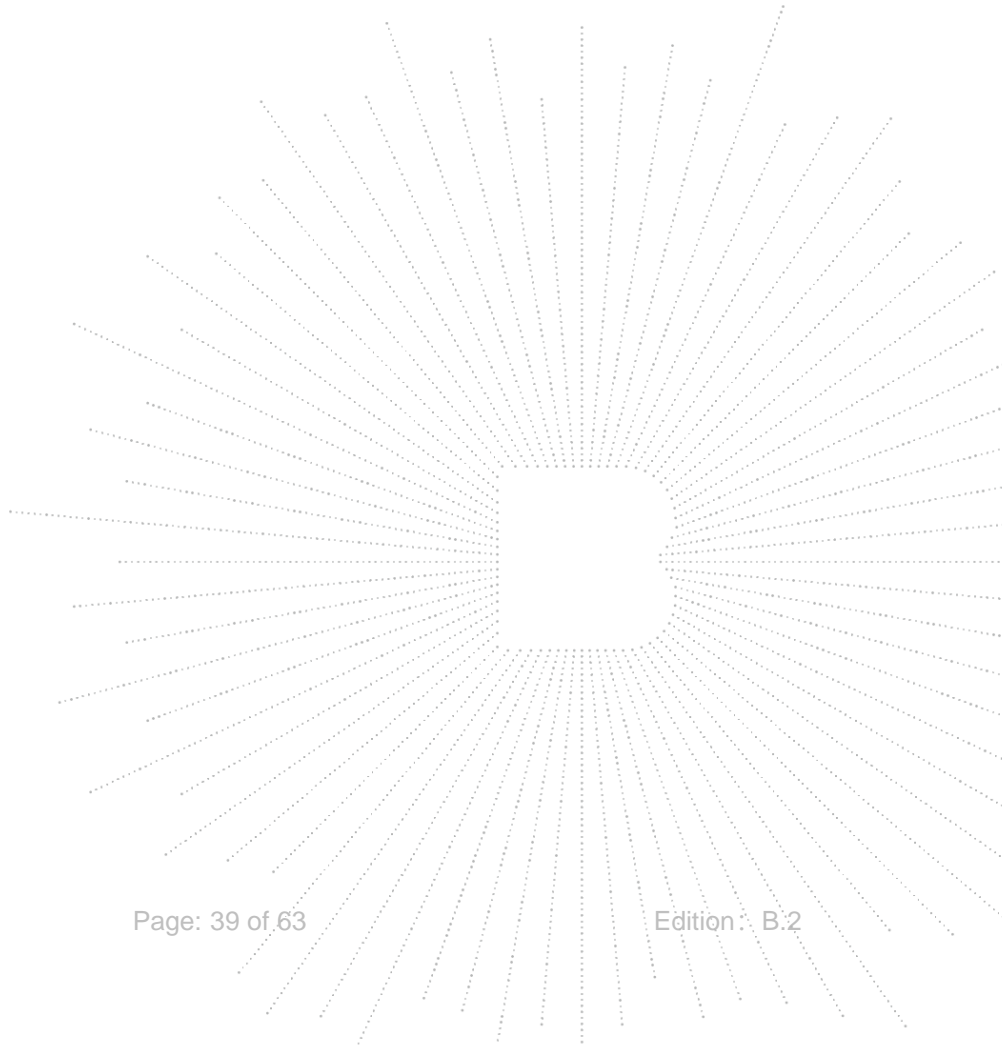
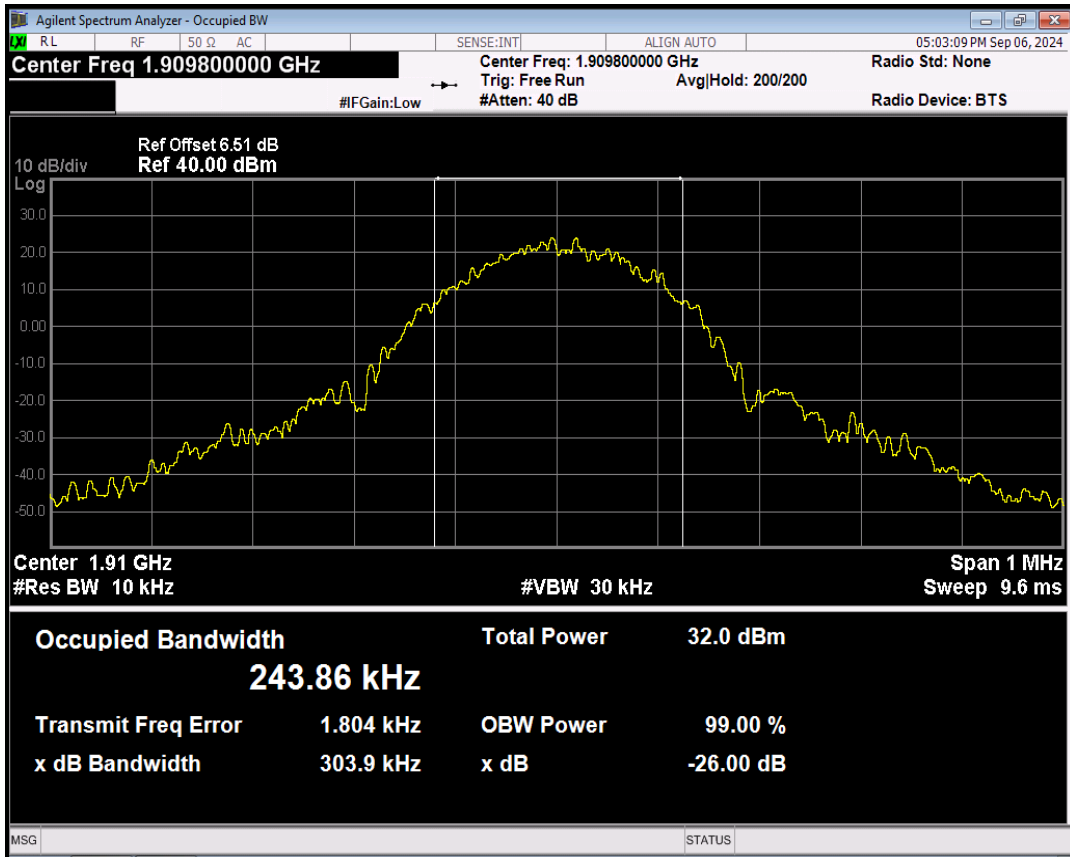

9. Out of Band Emissions at Antenna Terminal

9.1 Block Diagram Of Test Setup

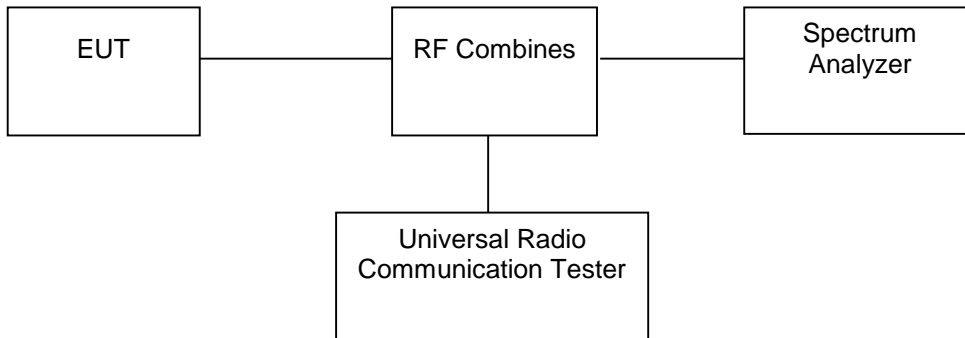

9.2 Limit

According to §22.917(a), the power of any emissions outside of the authorized operating frequency ranges must be attenuated below the transmitting power (P) by a factor of at least $43 + 10 \log(P)$ dB.

According to §24.238(a), the power of any emissions outside of the authorized operating frequency ranges must be attenuated below the transmitting power (P) by a factor of at least $43 + 10 \log(P)$ dB.

According to §27.53 (h), the power of any emission outside a licensee's frequency block shall be attenuated below the transmitter power (P) in watts by at least $43 + 10 \log_{10}(P)$ dB.

9.3 Test procedure

The RF output terminal of the transmitter was connected to the input of the spectrum analyzer via a suitable attenuation. The RBW of the spectrum analyzer was set to 100kHz and 1MHz for the scan frequency from 30MHz to 1GHz and the scan frequency from 1GHz to up to 10th harmonic. At the edge of the authorized Frequency block/band: RBW set 1%-5%OBW.

9.4 Test Result

GSM1900 Channel=512

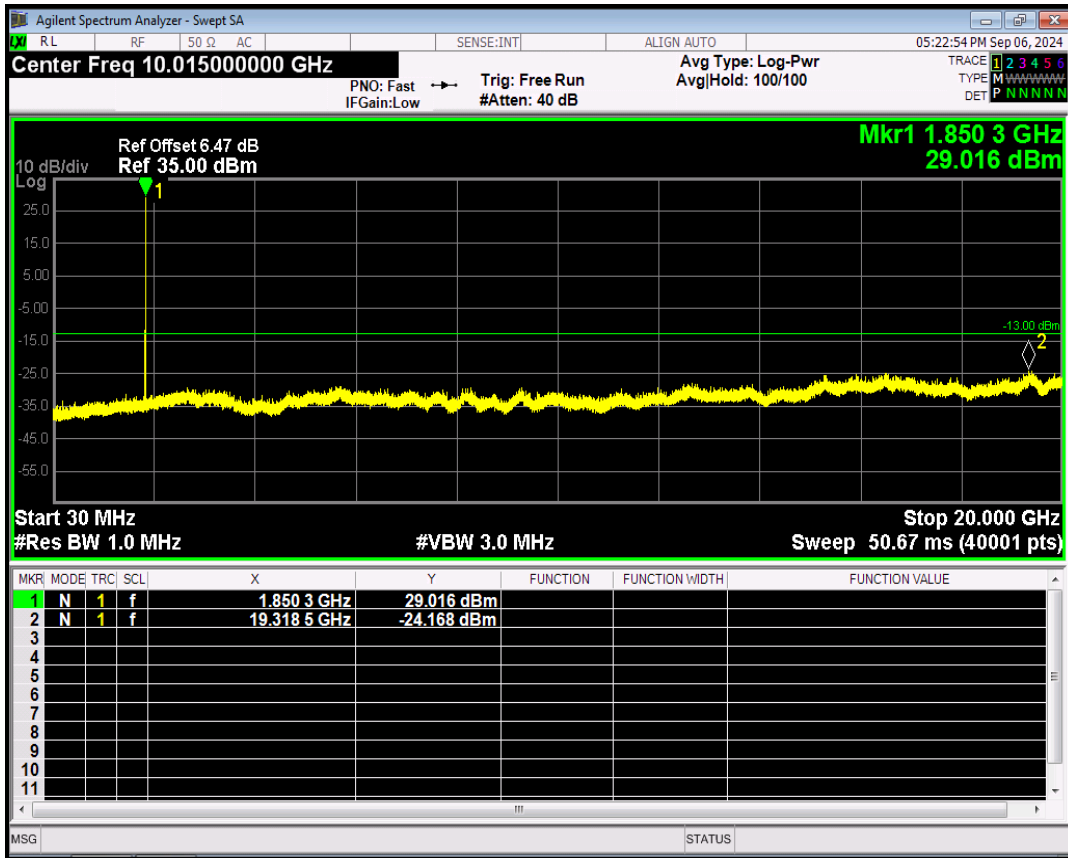

GSM1900 Channel=661

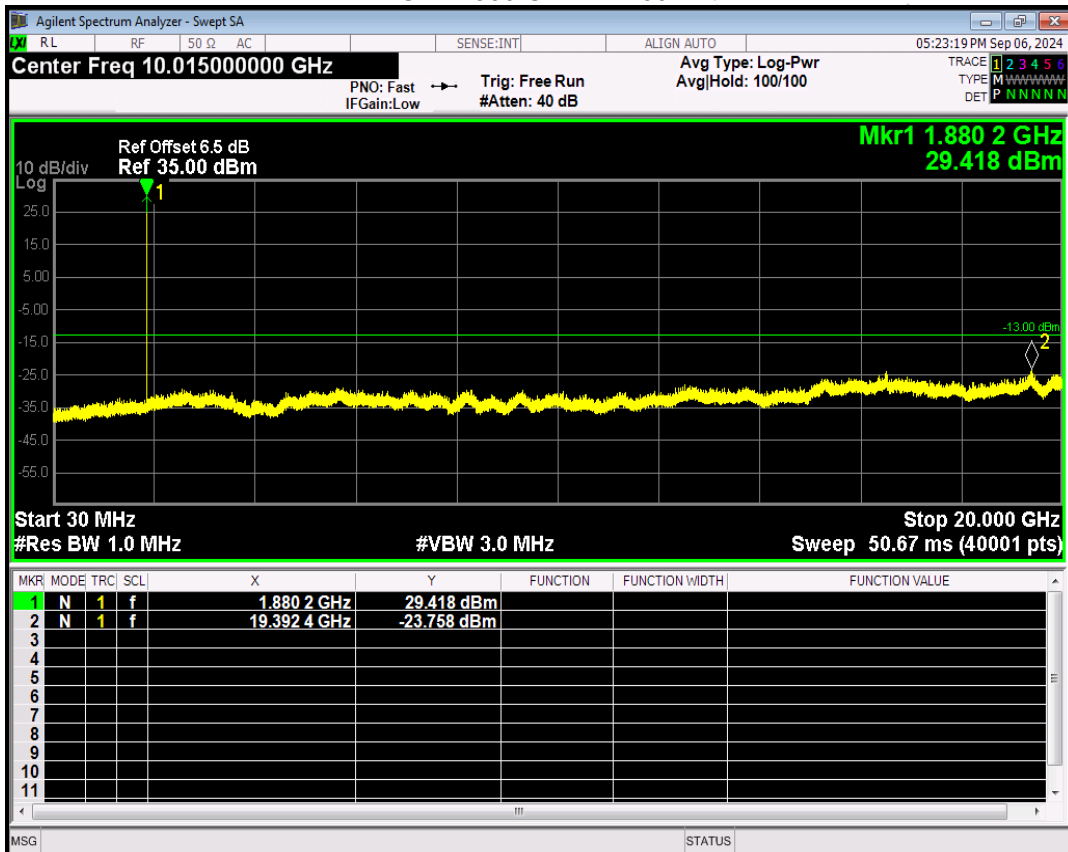

GSM1900 Channel=810

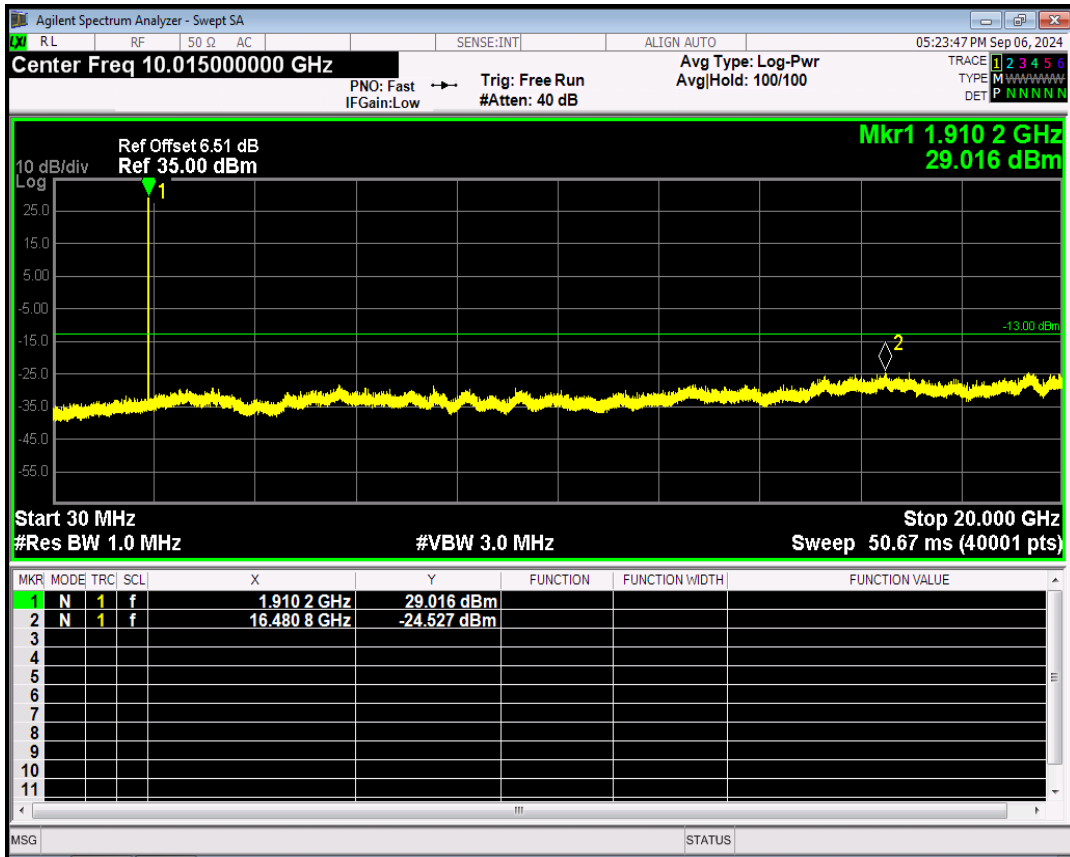

GSM850 Channel=128

