

EasyScan™ M10
User
Manual

EPiC

<http://www.epiclidar.cn>

Wuhan Eleph-Print Tech Co., Ltd

EasyScan™ M10
Handheld 3D Laser Scanning
System

User Manual

Catalog

1 Product Introduction	1
1.1 Product Overview	1
1.2 Technical Specification	2
2 Product Configuration	3
2.1 Scanner	3
2.2 Mainframe	3
2.3 Battery	4
2.4 Cable	5
2.5 Backpack Kit	5
3 Installation & Disassembly	6
3.1 Installation Preparation	6
3.2 Installation & Disassembly	7
4 Operation	12
4.1 Device Startup	12
4.2 Camera Operation	12
4.3 Device Connection	12
4.4 Device Power-off	12
4.5 Battery Charging	13
5 Data Collection	14
5.1 Operation Software Installation	14
5.2 Software Startup	17
5.3 Software Interface	17
5.4 Parameter Settings	18
5.5 Data Collection	18
5.6 Data Transfer	18
6 Appendix	19
6.1 Routine Maintenance	19

1 Product Introduction

1.1 Product Overview

The M10 is a handheld SLAM 3D laser scanning system independently developed by Wuhan Eleph-Print Tech Co., Ltd. Its designed based on the concept of making a highly lightweight and user-friendly laser scanner with integrating multiple technologies such as multi-line LiDAR, imaging, and inertial navigation acquisition, angle measuring sensor, etc. to ensure rapid and effective acquisition of high-precision true-color point clouds under any circumstances, which redefines the development direction of handheld SLAM 3D laser scanners in industry.

With its compact and lightweight design,fast and efficient performance, the M10 can be widely used in building facade surveying, accident scene investigation, stack volume calculation, interior renovation, underground space scanning, planar elevation profile drawing, digital park, and other fields.

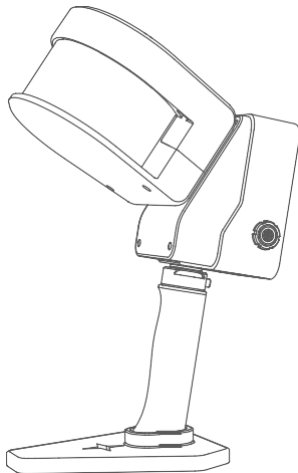

1.2 Technical Specification

		Technical Specification
M10 Technical Specification	Weight (handheld part only) ①	≤1.8Kg
	Size	L182 × W82 × D290(mm)
	Power Consumption	20W(Typical)
	Power Supply	18~20V DC
	Continuous Operation Duration	4h(single battery)
	Memory Storage	USB flash 64GB
	Operating Temp.②	-10°C-50°C
	Storage Temp.	-20°C-60°C
	Supported Platform	Handheld/ Backpack
	Max. Scanning Distance	120m
Laser Scanning Unit	Laser Class	Class 1
	FoV	260°Cx360°C
	Laser Length	905nm
	Scanning Rate	320,000pts/s
	Relevant Accuracy③	2cm
	Absolute Accuracy	5cm
Camera Unit (Backpack)	FoV	360°
	Resolution	18MP

Note:

①Overall weight:2.74kg and Mainframe 0.94kg included.

②Testing temp. 25°~27°.

③The ranging accuracy may be affected by the distance of the target object, environmental temperature, and target object reflectivity. The typical values are the average measurements of each channel within a range of 0.5m to 70m, at an outdoor environmental temperature of 30°C and a target object reflectivity of 50%.

2 Product Configuration

M10 has 2 versions, standard version and advanced version.

Standard version includes handheld scanner,mainframe,battery, cable,USB flash,etc.

Advanced version includes handheld scanner, mainframe, battery, cable,panoramic camera kit,USB flash,GNSS kit, backpack frame kit,etc.

2.1 Scanner

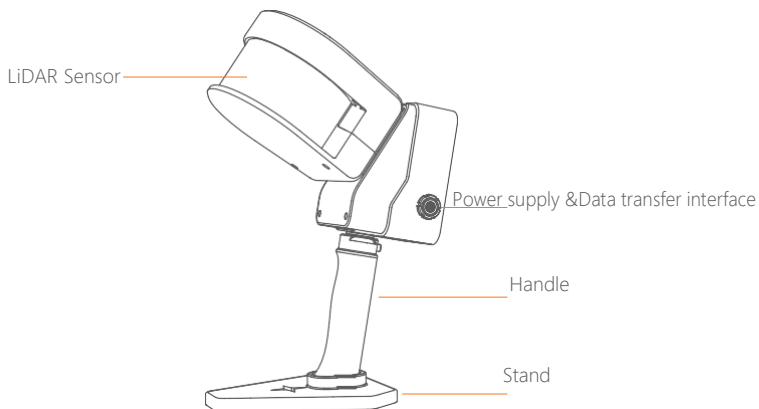

Pic. 2-1 M10 product configuration

2.2 Mainframe

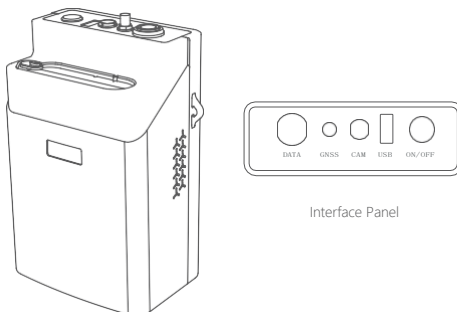

Pic. 2-2 M10 Mainframe

2.3 Battery

The M10 system is powered by a lithium battery, as shown in the following picture,

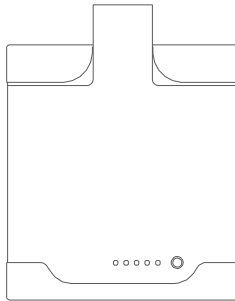

Pic. 2-4 M10 battery

Warning:

- Do not immerse the battery in liquid (such as water, seawater, etc.). When not in use, the battery should be placed in a cool and dry environment.
- Do not place the battery near high temperature sources (such as fire, heater, etc.) or use it nearby.
- Do not hit, compress, throw, or step on the battery.

2.3.1 Battery Power on

When the battery is in the off state, press the power button once briefly and then press and hold the power button for more than 2 seconds to turn on the battery. When the battery is turned on, the power indicator light will be constantly red and the battery level indicator light will display the current battery level.

2.3.2 Battery Power off

When the battery is in the on state, press the power button once briefly and then press and hold the power button for more than 2 seconds to turn off the battery. After the battery is turned off, all indicator lights will go out.

2.4 Power cable & Data transfer cable

The M10 is equipped with 3 cables, one data transfer cable, one camera cable and one GNSS cable, as shown in the following figure,



Pic. 2-5 Data transfer cable



Pic. 2-6 Camera cable



Pic. 2-7 GNSS cable

Data transfer cable: Used for connection between Scanner and Mainframe

Camera cable: Used for connection between camera and Mainframe

GNSS cable: Used for connection between M10 antenna and Mainframe

Note:

The above cable is a directional connecting cable. When connecting, make sure that the positioning pin (red dot indicator on the connector) is facing upward.

Warning:

The above cable is a system-specific cable. Please do not mix or use other cables to connect equipment;

2.5 Backpack Frame Kit

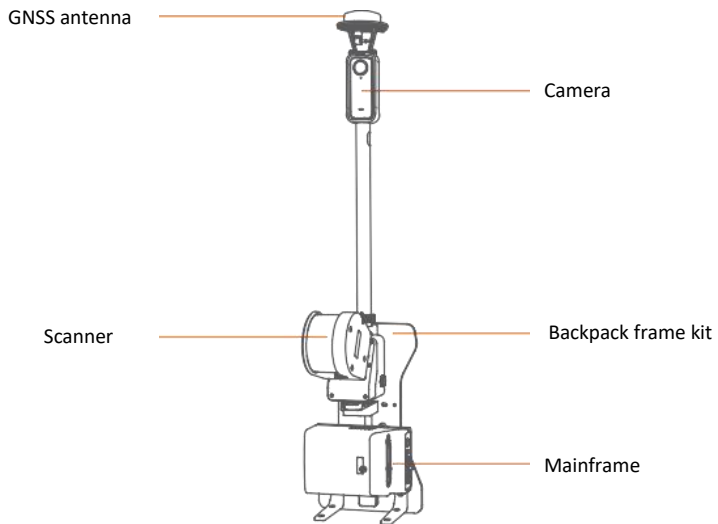

3 Installation and Disassembly

3.1 Installation Preparation

Before installation, check out the following configuration list to ensure the completeness of system.

Configuration list of standard version as below,

Type	No.	Item	Unit	Qty.
Device	1	M10 scanner	PCS	1
	2	Mainframe	PCS	1
	3	Battery	PCS	2
	4	Charger	PCS	1
Cables	1	Power supply&Data transfer cable	PCS	1
Others	1	Dongle	PCS	1
	2	《M10 user manual》	PCS	1
	3	《M10 configuration list》	PCS	1
	4	《Qualified card》	PCS	1
	5	《Warranty card》	PCS	1

Configuration list of advanced version as below,

Type	No.	Item	Unit	Qty.
Device	1	M10 Scanner	PCS	1
	2	Mainframe	PCS	1
	3	Battery	PCS	2
	4	Charger	PCS	1
	5	Backpack frame kit	PCS	1
	6	Panoramic camera kit	PCS	1
	7	GNSS kit	PCS	1
	8	Shoulder strap	PCS	1
Cables	1	Power supply&Data transfer cable	PCS	1
	2	Camera cable	PCS	1
	3	GNSS cable	PCS	1
Others	1	Dongle	PCS	1
	2	《M10 user manual》	PCS	1
	3	《M10 configuration list》	PCS	1

4	《Qualified card》	PCS	1
5	《Warranty card》	PCS	1

3.2 M10 Installation and Disassembly

Warning:

- When installing M10 system equipment, please handle it with care to protect the equipment.
- When installing or dismantling the equipment, please ensure that it is in the off state to avoid damaging the equipment due to live operation.
- After dismantling the equipment, please put each component back into the packaging box according to its designated location and check if everything is complete.

3.2.1 Battery Installation

Make sure that the battery is turned off. Insert the battery into the built-in battery compartment in the direction shown by the arrow, gently push it to the bottom, and then rotate the buckle to secure the battery.

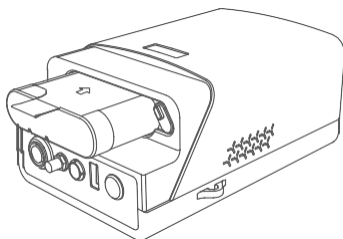

Pic. 3-1 Battery Installation

Warning:

- The battery used by the M10 system has a specific installation direction. Please pay attention to the installation direction of the battery when installing it.
- When installing the battery, please handle it gently to avoid excessive force causing damage to the device.

3.2.2 Battery Disassembly

Make sure the M10 system is turned off, push the latch to open the battery compartment, and remove the battery from the compartment in the direction indicated by the arrow.

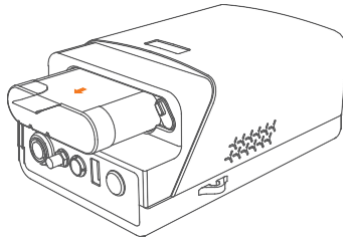

Pic. 3-2 Battery Disassembly

3.2.3 Installation of Scanner Handle

Make sure the M10 system is turned off, align the handle quick-mounting groove with the quick-mounting slider at the bottom of the scanner, and insert the handle into the quick-mounting slider. At the same time, the button on the handle quick-mounting groove will pop out, then it means its a successful installation.

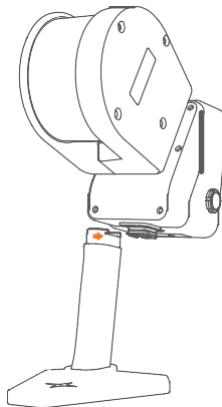

Pic 3-3 Installation of Scanner handle

3.2.4 Disassembly of Scanner Handle

Ensure that the M10 system is turned off. Press and hold the quick-mount slider button, and move the electric handle in the direction of the slider to remove it.

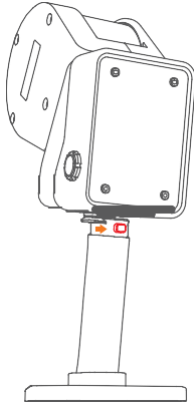

Pic. 3-4 Scanner handle

3.2.5 Installation of Scanner and Backpack frame kit

Make sure the M10 system is turned off, remove the handle, align the quick-mount slider at the bottom of the scanner with the slot on the backpack, insert the scanner into the slot, and when the quick-mount slider button pops out, it means installation is successful.

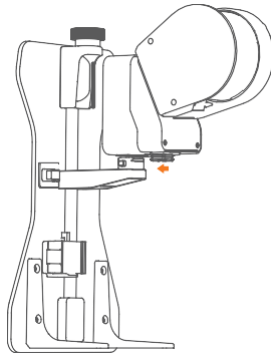

Pic. 3-5 Installation of Scanner and Backpack frame kit

3.2.6 Disassembly of Scanner and Backpack frame kit

Make sure the M10 system is turned off, hold down the quick-mount slider button, and move the scanner in the direction of the arrow to detach it."

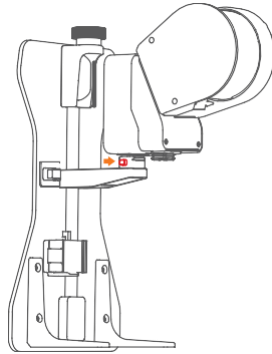

Pic. 3-6 Disassembly of Scanner and Backpack frame kit

3.2.7 Installation of Mainframe and Backpack frame kit

Make sure the quick-release slider on the mainframe is in the unlocked position, press the latch, place the mainframe horizontally so that the quick-release slider on the mainframe aligns with the quick-release slider on the backpack, insert it into the slider slot, release the latch, and installation is complete.

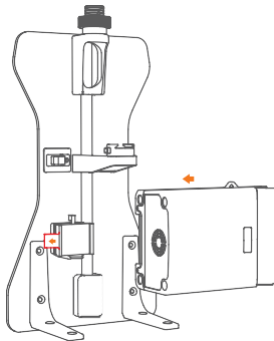

Pic. 3-7 Installation of Mainframe and Backpack frame kit

3.2.8 Disassembly of Mainframe and Backpack frame kit

Make sure that the quick-install sliding groove of the mainframe is in the unlocked state. Press the buckle and move the mainframe along the direction of the arrow to complete the disassembly of the mainframe.

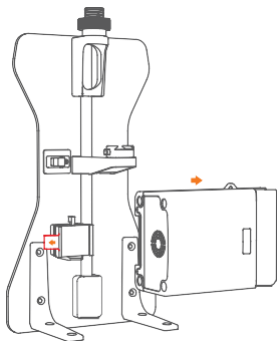

Pic. 3-7 Disassembly of Mainframe and Backpack frame kit

4 Operation

4.1 System Startup

After completing the device installation steps described in section 3.2, you can start using the M10 system. To do so, turn on the battery and wait for 2 seconds, then press the power button on the M10 mainframe. The indicator light will turn on and the device will start.

Once the indicator light turns on, you can search for the "M10" WiFi hotspot using your phone or tablet. This means that the system has started up normally.

Note: Please be patient during the initialization period of the system, which typically takes less than a minute after startup.

4.2 Camera Operation

Once the M10 system is powered on, long press the camera power button for 3 seconds.

4.3 Connection with Mainframe

The M10 system provides wireless connection options

1. Use a mobile phone or tablet to search for WiFi hotspots and find the WiFi access point named "M10-xxxxx".
2. Join the "M10" hotspot using the password "12345678", and set the wireless network IP acquisition method to be automatically.

Note: The IP of the M10 system is 192.168.0.110

4.4 Mainframe Power off

When the system stops collecting data and the data transmission is complete, the device can be turned off by clicking the 'Shutdown' button on the software, as shown in the following picture.

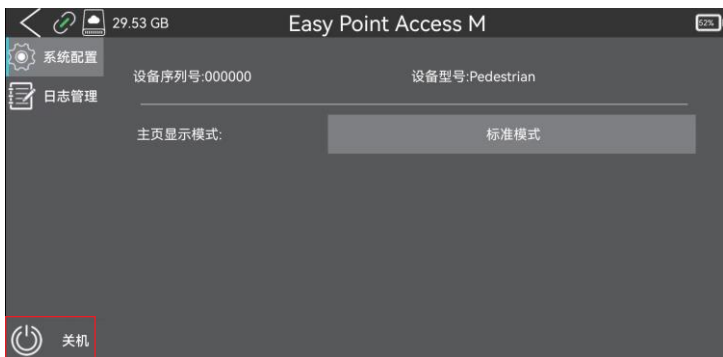

Pic. 4-1 System Shutdown

When the M10 mainframe indicator is off, turn off the battery, then the system is fully shut down.

- Warning:
- Do not directly power off the mainframe before it has fully shut down to prevent equipment damage.
- When transporting the device after it has been turned off, please remove the battery from the battery compartment and place it in a dedicated battery box or in the battery slot of the device packaging box.

4.5 Battery Charging

The M10 system equipment's lithium battery is charged using a specialized charger, as shown in the following image

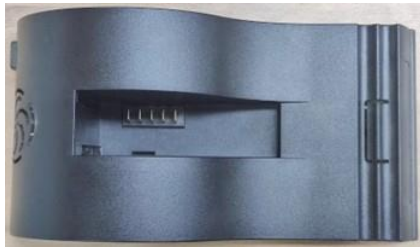

Pic. 4-2 M10 charger

WARNING:

- Please discharge the battery to around 50% capacity if it is not used for more than 10 days.
- If the battery is idle for a long time, please charge and discharge it once every three months or so to maintain battery activity.

5 Data Collection

5.1 Operation Software Installation

Insert the USB flash drive into the PC. Copy the "Easy Point Access M xxx.apk" installation package from the USB flash drive to the PC. Connect your phone to the PC using a USB cable and copy the installation package to the "download" folder on your phone. Finally, access the "download" folder on your phone, select the installation package and click "install".



Pic. 5-1 Operation Software Installation

And authorize the required permissions for the software in the pop-up permission dialog box. If you do not authorize them, some functions of the software may not be available. Click "Continue Installation" and wait for the software to finish installing.

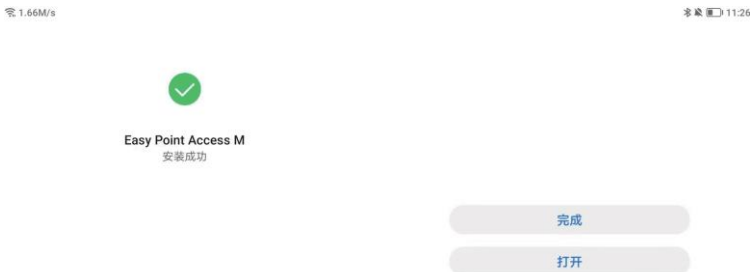

Pic. 5-2 Operation Software Installation

Note: The recommended platform are Android 10, 11, and 12, as well as HarmonyOS 3.0.
Examples of compatible devices are as follows:

1 · Tablet PC Honor 7



2 · Tablet PC XIAOXIN 2022



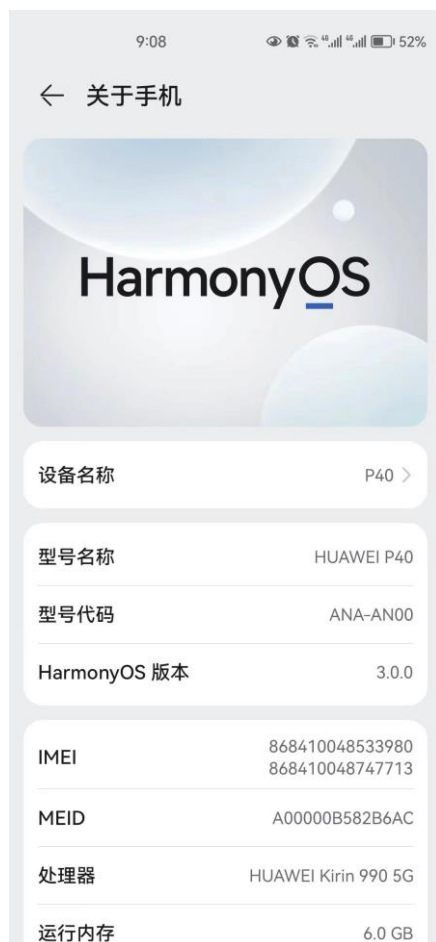

Pic. 5-4 Recommended configuration of phone

5.2 Operation Software Startup

Power on and wait for 30 seconds. The device ID is M10XXXX (XXXX represents the device SN)

The initial password for WIFI is 12345678. Open the app on your mobile device."

5.3 Operation Software Interface

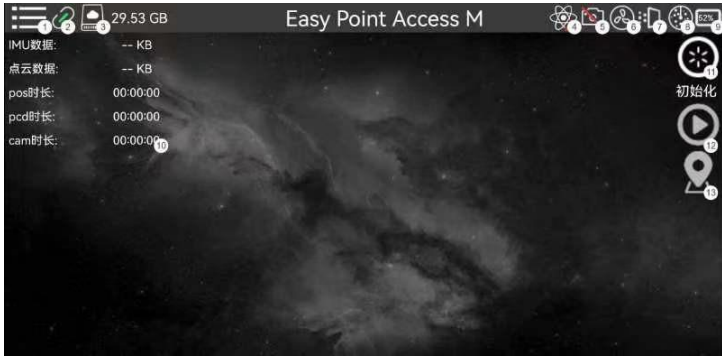

Pic. 5-5 Software Interface

- 1.Set button, click to enter the settings interface.
- 2.Display device connection status, with changes between connected and disconnected states.
- 3.Display remaining storage space on USB drive.
- 4.Display satellite signal status, with indication of whether there is or is not a satellite signal.
- 5.Display camera connection status, with changes between connected and disconnected states.
- 6.Display POS collection status, using animation during the collection process to indicate that collection is in progress.
- 7.Display motor rotation status, using animation during rotation to indicate that rotation is in progress.
- 8.Display point cloud collection status, using animation during collection to indicate that collection is in progress.
- 9.Display battery level status, with real-time display of battery percentage. Low

battery will be indicated with a prompt to recharge.

10.Display data growth for all data collected during the collection process.

11.Initialization button, click to begin initialization and device starts collecting POS.

12.Start collection button, click to begin collecting point clouds.

13.Mark button, click to mark a point.

5.4 Parameters Settings

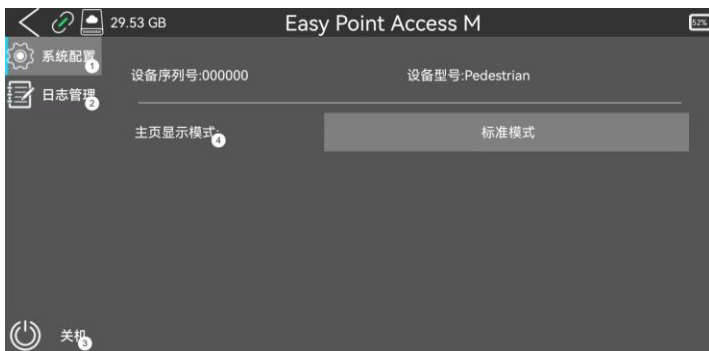

Pic. 5-6 Parameters Settings

- ① Device collection mode setting
- ② View data collection log
- ③ Shutdown button, click to turn off the device
- ④ Home display mode setting, standard mode has real-time point cloud display, while simple mode does not

5.5 Data Collection

After setting up the data acquisition parameters, return to the main interface and click the "Initialization" button first. The device will start collecting POS data. Wait for initialization to complete (30 seconds), then click the "Start Collection" button to automatically begin collecting point cloud data. If you need image data, remain stationary for 10 seconds and then click the camera button to take timed shots. After collecting all the point cloud data, all data will be stored in the corresponding folder according to the specified format.

When all station data has been collected, remove the USB drive and copy the collected data to a computer. Then, use post-processing software to perform data processing.

5.6 Data Copy

Remove the USB drive from the device, insert it into the computer, open the USB drive, and name the folder after the date when the data was collected. Each folder should contain point cloud and image data.

6 Appendix

6.1 Routine Maintenance

- ① When using the equipment, please handle it gently and avoid knocking it;
- ② After the laser equipment has finished collecting, the laser protection cover should be put on to prevent scratches on the laser lens;
- ③ In daily use, pay attention to protecting it and avoid scratching its appearance. If there is dust, use a dust-free cloth dipped in clean water to gently wipe it;
- ④ After using the device, it is necessary to remove the accessories and put the mainframe and accessories into the packaging box.

6.2 Common Troubleshooting

After turning on the camera, it shuts down immediately, which may be because the camera has not been charged for a long time and the battery is low. Opening the device and charging the camera for about 10 minutes will allow it to start up normally.

If the camera does not take pictures during use, please manually turn on the camera.

If the U disk is plugged and unplugged multiple times during the collection process, it may cause the laser scanner's configuration parameters to be reset to factory settings. If this happens, please contact the after-sales personnel for remote setting of the scanner. After successful setting, it will not affect the normal use of the device.

FCC Warning

This device complies with part 15 of the FCC Rules. Operation is subject to the following two conditions: (1) This device may not cause harmful interference, and (2) this device must accept any interference received, including interference that may cause undesired operation.

Any Changes or modifications not expressly approved by the party responsible for compliance could void the user's authority to operate the equipment.

Note: This equipment has been tested and found to comply with the limits for a Class B digital device, pursuant to part 15 of the FCC Rules. These limits are designed to provide reasonable protection against harmful interference in a residential installation. This equipment generates uses and can radiate radio frequency energy and, if not installed and used in accordance with the instructions, may cause harmful interference to radio communications. However, there is no guarantee that interference will not occur in a particular installation. If this equipment does cause harmful interference to radio or television reception, which can be determined by turning the equipment off and on, the user is encouraged to try to correct the interference by one or more of the following measures:

- Reorient or relocate the receiving antenna.
- Increase the separation between the equipment and receiver.
- Connect the equipment into an outlet on a circuit different from that to which the receiver is connected.
- Consult the dealer or an experienced radio/TV technician for help.

This equipment should be installed and operated with minimum distance 20cm between the radiator & your body.