

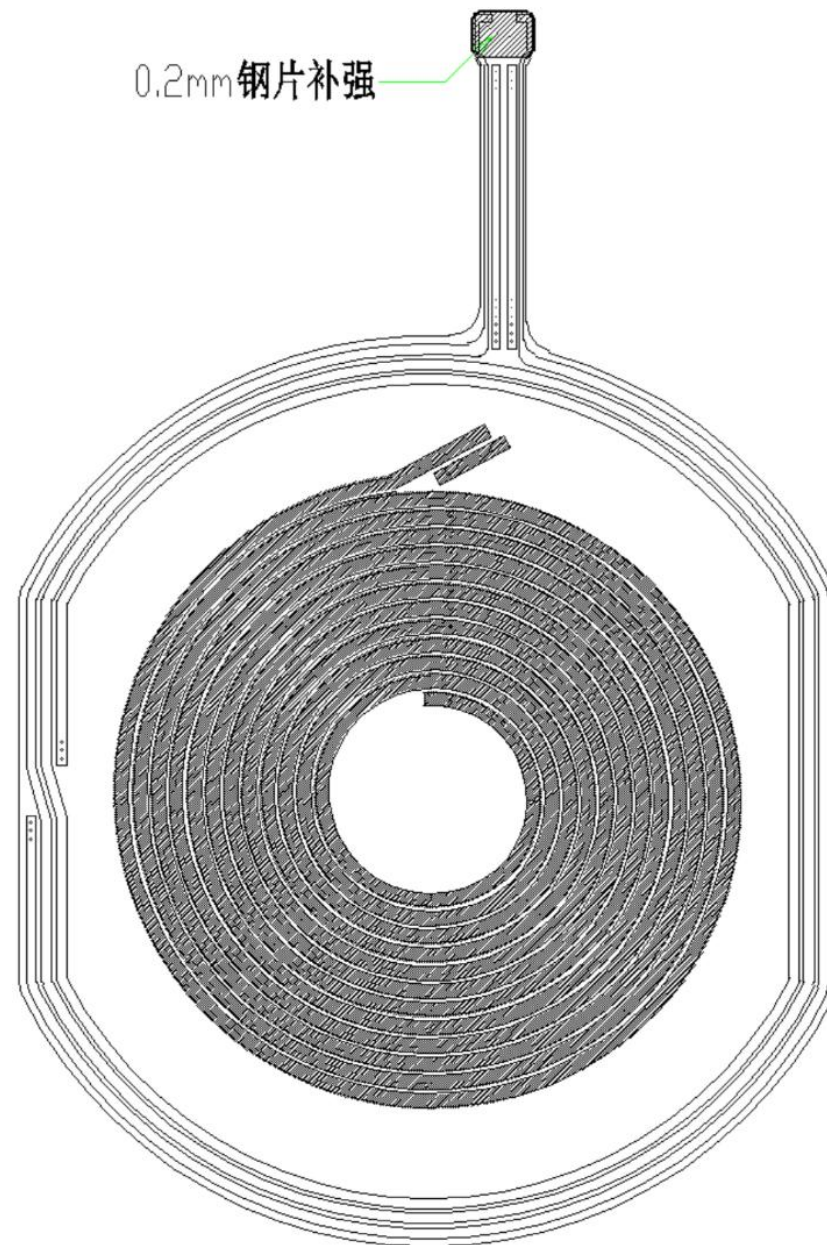

3100 - NFC天线调试报告 V2.0

- 线圈尺寸: 60mm×54mm
 - 线圈+铁氧体总厚度: 0.40mm
 - 天线版本: V1.0
- 线宽0.7mm 线距0.3mm 3圈



线圈参数

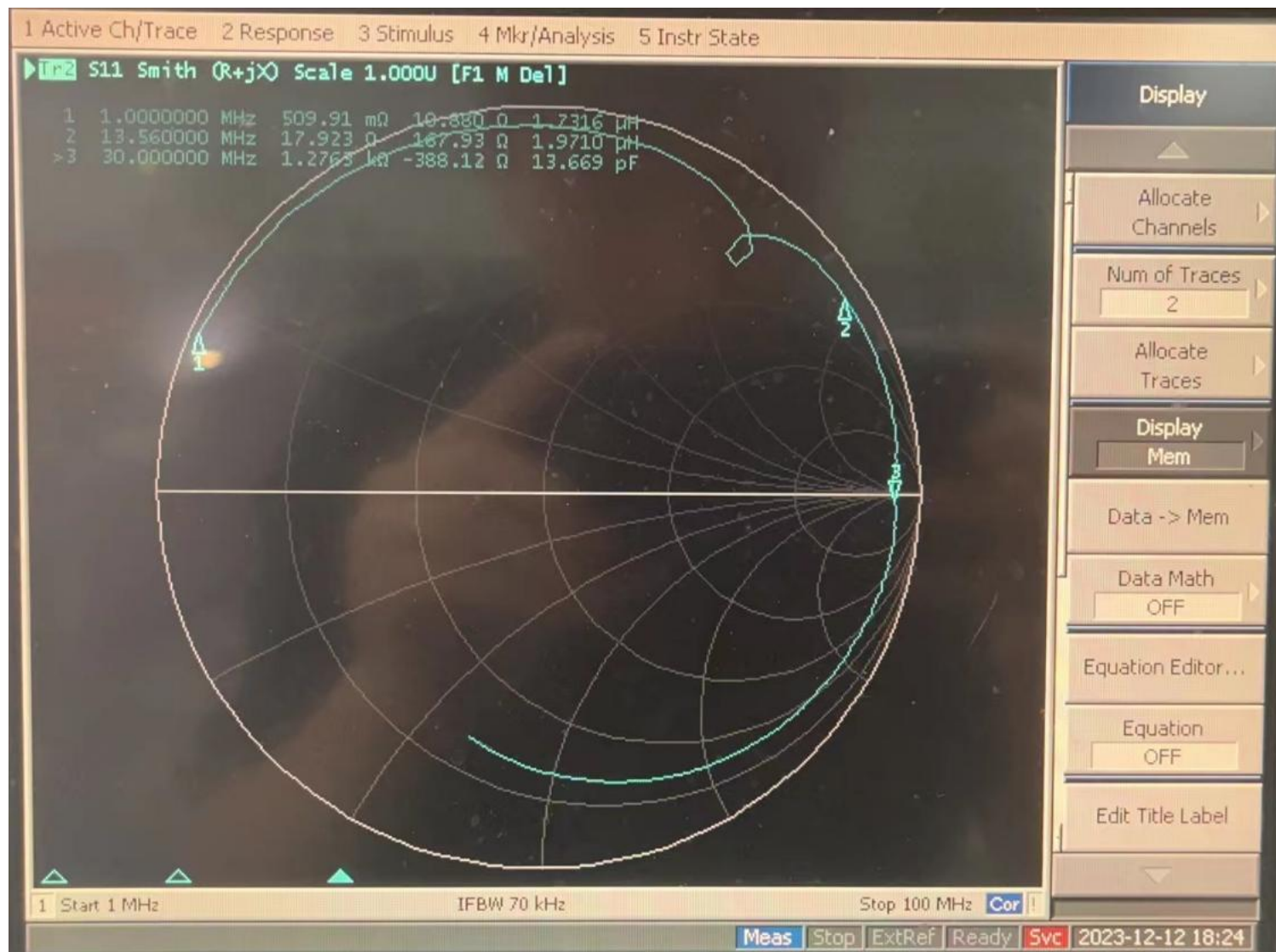

阻抗参数	
RP(Ω) 13.56Mhz	17.92
Rs(Ω) @1MHz	0.51
La(μH)@13.56M Hz	1.97
电抗X(Ω)	8.9
Fra(MHz)	30.0

目前测试环境：

- 基于客户提供的整机进行NFC天线设计和匹配调试，整机环境下测试单独天线史密斯图计算匹配。

Smith Chart



电路图

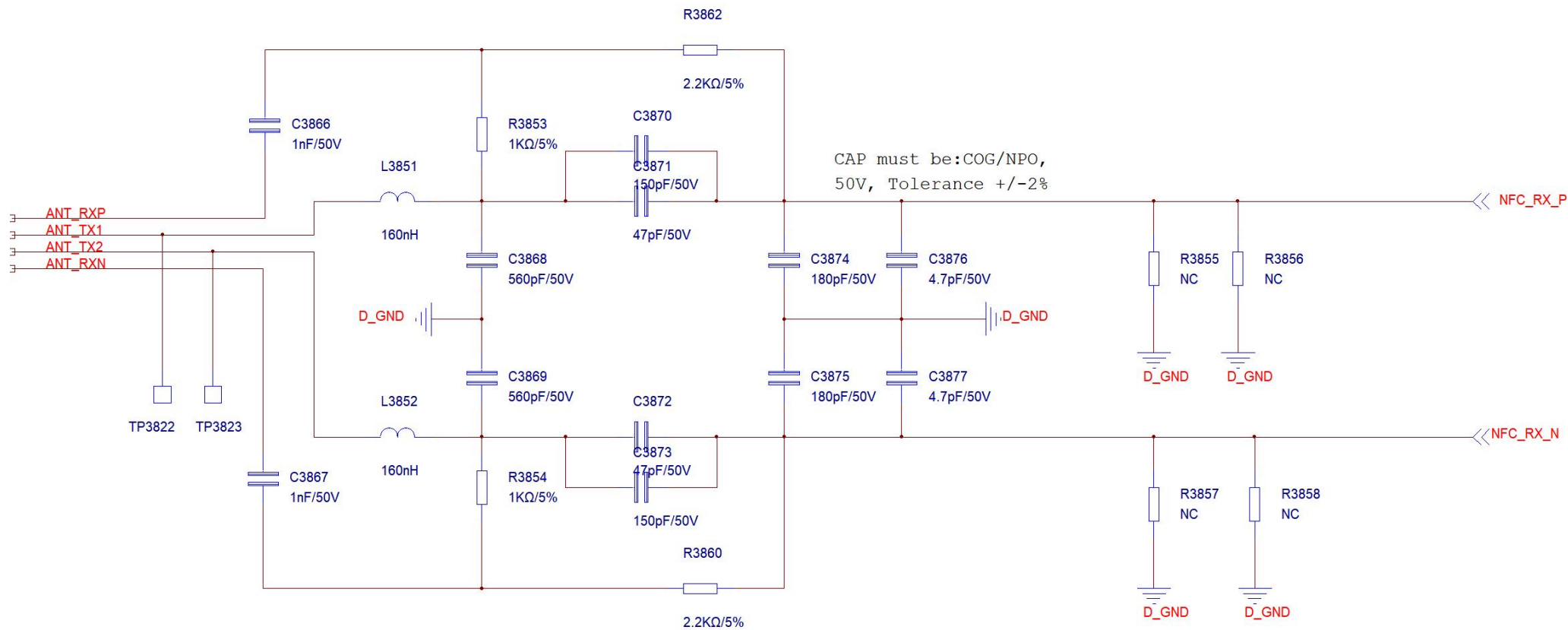

匹配电路

元器件	大小	位号	型号	料号
Lo	160nH	L2002+L2003	0603电感	
C0	680pF	C3868+C3869	0402电容	CC0402FRNPO9BN681
Cs1	82PF	C3871+C3871	0402电容	CC0402FRNPO9BN820
Cs2	4.0PF	C3870+C3873	0201电容	CC0201CRNPO9BN4R0
Cp1	100PF	C3876+C3877	0402电容	CC0402FRNPO9BN101
Cp2	15PF	C3874+C3875	0402电容	CC0402FRNPO9BN150

注：红色为匹配改动项，
黑色为贴片状态无改动



NFC天线测试设备

- NFC Forum Tag
 - ✓Type 1 tag (Topaz)
 - ISO14443 Type A, 96byte memory, 106kbit/s data rate
 - ✓Type 2 tag (Mifare Ultralight)
 - ISO14443 Type A, 48byte memory, 106kbit/s data rate
 - ✓Type 3 tag (Felica)
 - Sony Felica, 2kbyte memory, 212kbit/s data rate
 - ✓Type 4 tag (Mifare Desfire)
 - ISO14443 Type A/B, 32kbyte memory, 106-424kbit/s
 - ✓Type 5 tag
 - ISO15693



项目	3100	
分类	测试设备	测试结果 (mm)
读卡器模式通讯距离	T1T (Topaz-512)	≤40
	T2T(Mifare Ultralight)	≥40
	T3T(Felica)	≥40
	T4T(Mifare Desfire)	≥20
	T5T (ISO 15693)	≤38

Thank you

