



# Owner's Manual

## Legacy Series

305 LP, 500 ASM, 750 ASM, 1000 ASM, 1600 ASM  
Automated Power Bundle



**IMPORTANT: READ THIS MANUAL IN  
ENTIRETY BEFORE OPERATING**

# Table of Contents

<b>General Safety</b>	<b>5</b>
Safety Instructions	5
<b>Quick-Start Installation</b>	<b>6</b>
<b>Detailed Installation Instructions</b>	<b>6</b>
1. Mount the Sprayer	6
2. Charge the Battery	6
3. Assemble the Boom	7
4. Assemble and Install Boom Hoses	10
5. Connect to Sprayer Via Bluetooth	10
6. Connect Sprayer to WiFi	11
7. Pair Remote to Sprayer	11
8. Install the Antenna	12
<b>Product Overview</b>	<b>13</b>
Remote Controls Overview	15
Specifications	17
Attachments and Accessories	17
<b>Before Operation</b>	<b>18</b>
Before Operation Safety	18
Fuel Specifications	19
Filling the Fuel Tank	19
Side Boom Nozzle Positions	19
Center Boom Nozzle Positions	20
Sprayer Control Box Light Modes	21
Navigation the VSI Spray Control App	23
Understanding Sprayer Valve Positions	27
<b>During Operation</b>	<b>29</b>
During Operation Safety	29
Starting the Engine	29
Using the Sprayer	30
<b>After Operation</b>	<b>30</b>
After Operation Safety	30
<b>Maintenance</b>	<b>31</b>
Recommended Maintenance Schedule(s)	31
Maintenance Safety	31
Lubrication	32
Lubricating the Machine	32

Engine Maintenance	32
Engine Safety	32
Engine Oil Specification	32
Checking the Engine-Oil Level	33
Changing the Engine Oil	33
Checking the Air-Filter Elements	33
Servicing the Air Cleaner	34
Cleaning the Foam Air-Filter Element	34
Cleaning the Paper Air-Filter Element	34
Assembling the Air Filter Elements	35
Servicing the Spark Plug	35
Fuel System Maintenance	35
Cleaning the Sediment Cup	36
Electrical System Maintenance	36
Electrical System Safety	36
Replacing the Fuses	36
Charging the Battery	36
Charging the Remote	37
Sprayer System Maintenance	37
Inspecting the Tank Straps	37
Inspecting the Hoses	38
Pump Maintenance	38
Inspecting the Pump	38
Cleaning	38
Washing the Machine	38
Rinsing the Tank	38
Draining the Pump	38
Conditioning the Sprayer System	38
<b>Storage</b>	<b>39</b>
Storage Safety	39
Prepare the Machine for Storage	39
<b>Regulatory Statements</b>	<b>39</b>
FCC Statements	39
FCC Radiation Exposure Statement	40
ISED Statements	40
ISED RF Exposure Statement	40



# Introduction

This machine is a dedicated ice-control spray system and is intended to be used by trained operators for spraying ice-control solutions on residential or commercial properties. Using this equipment improperly or for purposes other than its intended use may prove dangerous to you and others. You are responsible for operating the equipment properly and safely.

Read this manual carefully to learn how to operate and maintain your equipment safely.

A digital version of this manual that can be accessed on the VSI Spray Control app (“Getting Started/FAQ” button on the Profile” tab).

If service, parts, or additional information is needed please contact VSI Technical Service (1-507-252-3033) for more information.

## General Safety

This product is capable of causing personal injury. Always follow all safety instructions to avoid personal injury.

- Read and understand the contents of this *Operator’s Manual* before starting the engine.
- Use your full attention while operating the machine. Do not engage in any activity that causes distractions; otherwise, injury or property damage may occur.
- Use appropriate personal protective equipment (PPE) to guard against contact with chemicals.
- Do not put your hands or feet near moving components of the machine.
- Do not operate the machine without all guards and other safety protective devices in place and in proper working order on the machine.

- Keep clear of any discharge area of the sprayer nozzles and spray area. Keep bystanders and children out of the operating area.
- Never allow children to operate the machine.
- Shut off the engine, remove the key, wait for all movement to stop, and allow the machine to cool before adjusting, servicing, cleaning, or storing it.

Improperly using or maintaining this machine can result in injury. To reduce the potential for injury, comply with these safety instructions and always pay attention to the safety alert symbol. Failure to comply with these instructions may result in personal injury or death.

## Safety Instructions

- Read the *Operator’s Manual*.
- All operators should be training before operating the machine.
- Wear hearing protection.
- Wear eye protection.
- Do not enter the tank.
- Remove the key and read the *Operator’s Manual* before performing maintenance.
- Do not put flammable liquids in the tank.
- Turn off the sprayer, shut off the machine, and remove the key before leaving the machine or performing maintenance.
- Stay away from moving parts; keep all guards and shields in place.
- Only lift an empty tank; do not lift the tank when full.
- Keep bystanders away while operating the machine.

# Quick-Start Installation

Follow the steps below to mount and install the sprayer for use.

1. Mount the Sprayer - Securely mount the sprayer and tank (if separate) to the truck.
2. Charge the Battery.
3. Assemble the Boom.
4. Assemble and Install the Boom Hoses.
5. Connect to the Sprayer via Bluetooth.
6. Connect Sprayer to WiFi.
7. Pair the Remote to Sprayer.
8. Install the Antenna.

- 1.3. Secure the sprayer to the truck using straps or chains connected to the tie-down points.

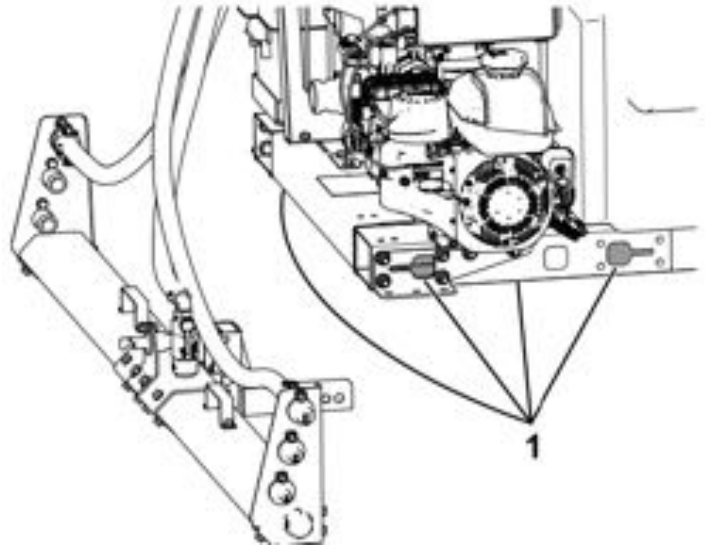

## Detailed Installation Instructions

### 1. Mount the Sprayer

- 1.1. Open the truck's tailgate (if equipped).
- 1.2. Using the forklift pockets on the sprayer, lift the machine on the vehicle bed. **NOTE: only lift an empty tank, do not lift the tank when full of liquids.**

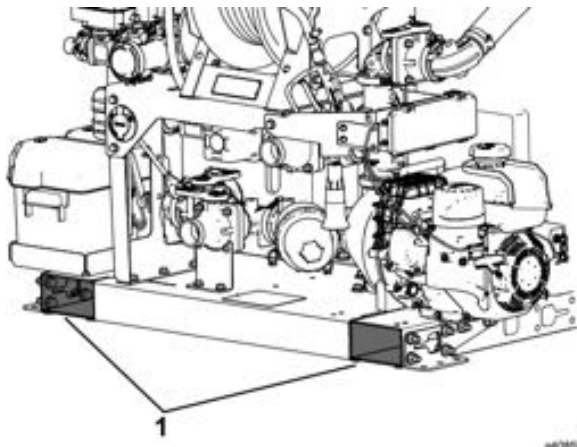

**Note:** If your vehicle has a stainless or powder-coated bed, it is recommended to add rubber mats under the length of the skid to prevent the machine from sliding on smooth surfaces.

### 2. Charge the Battery

The battery is not fully charged when you purchase the sprayer. Using the onboard battery tender and AC plug port, charge the battery until fully charged before using the sprayer for the first time. See *Charging the Battery* later in this manual.

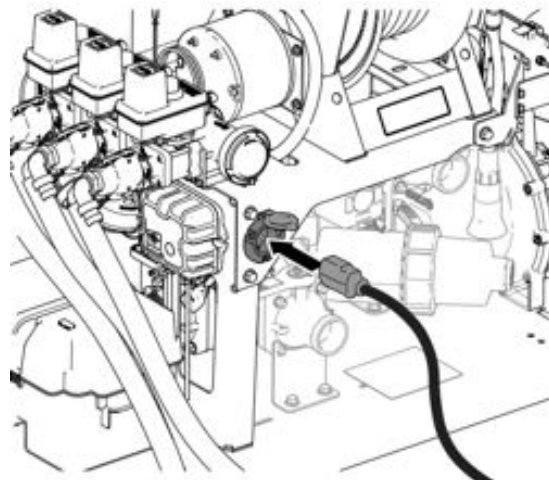

### 3. Assemble the Boom

The Legacy sprayer comes standard with an 84” Legacy Boom. This boom will come in two (2) boxes.

#### Tools Needed for Assembly

- Pipe Wrench
- Impact Driver
- Thread Sealant
- 9/16” Socket
- 9/16” Wrench
- Hose Cutter



#### Box 1: 84” Boom Shroud w/Pipe

**Box Dimensions: 47”L x 5”W x 3”H**

This box includes the following parts:

- 1 84” Boom Pipe Drivers Side
- 1 84” Boom Pipe Passenger Side
- 1 84” Boom Shroud Drivers Side
- 1 84” Boom Shroud Passenger Side



#### Box 2: Legacy Master Kit

**Box Dimensions: 24”L x 24”W x 7”H**

This box includes the following parts:

Parts for assembly of boom hose sections (See *Section 4: Assemble and Install Boom Hoses*):

- 25’ 1” EPDM Rubber Hose
- 6 1” Hose Clamps
- 2 1” Straight Barb Camlock Coupler (100C)
- 4 1” 90\* Barb Camblocks (100D w/ HB100-90)

Parts for assembly of the boom and hitch receiver:

- 1 Hitch Hardware Kit
- 1 Boom Hitch Receiver
- 1 Boom Side Height Adjustment Bracket
- 1 Boom Hardware Kit
- 1 Boom Handle
- 1 Center Boom Support
- 1 Center Fan Nozzle Holder
- 1 Boom Stainless Steel Coupling
- 1 Drivers Side Nozzle Mount
- 1 Passenger Side Nozzle Mount
- 1 Male Camlock Coupler (100A)
- 2 Boom Pipe Caps (CAP100)
- 1 Center Fan Boom Nozzle
- 2 Large Side Boom Spray Nozzle
- 2 Medium Side Boom Spray Nozzle
- 2 Small Side Boom Spray Nozzle



View a video of this boom assembly process on our YouTube channel:

<https://www.youtube.com/watch?v=gHtMyaZNYhM>



3.1. Pair the *84" Boom Shroud Drivers Side* and *84" Boom Shroud Passenger Side* using the *Center Boom Support*. Fasten together using hex bolts (3/8" x 1"), washers, and lock nuts.

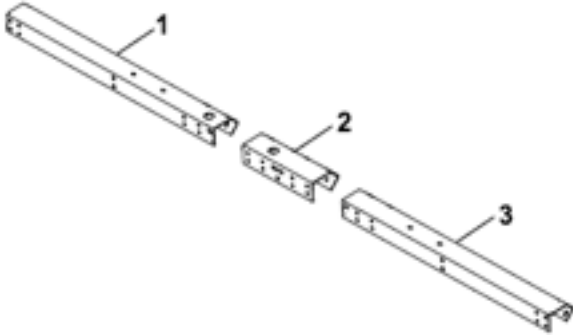

3.2. Install the *Boom Side Height Adjustment Bracket* using the Grade 8 "gold" hex bolts (1/2" x 1 1/4"), washers, and lock nuts.

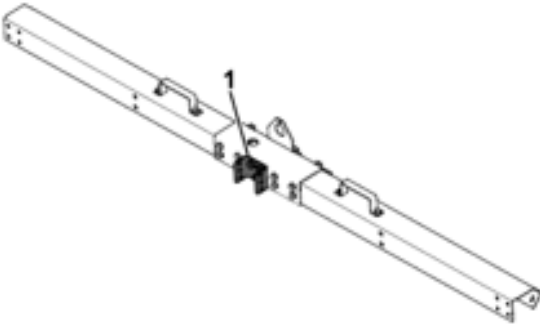

3.3. Install the *Boom Handle* (Qty: 2) on the shrouds. Fasten with hex bolts (3/8" x 1"), washers, and lock nuts.

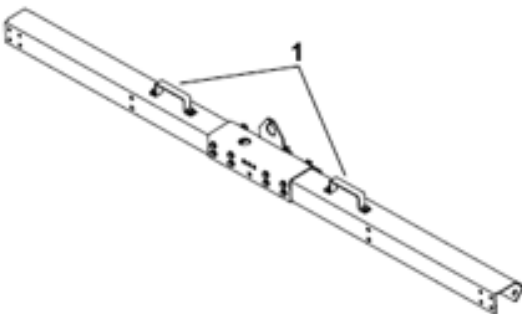

3.4. Install the *Passenger Side Nozzle Mount* on the end of the shroud. Fasten with hex bolts (3/8" x 1"), washers, and lock nuts.

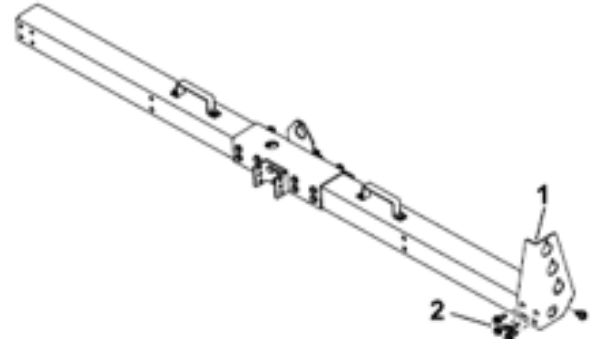

3.5. Install the *Center Fan Nozzle Holder* on the center of the *Center Boom Support*. Fasten using the already utilized hex bolts, washers, and lock nuts.

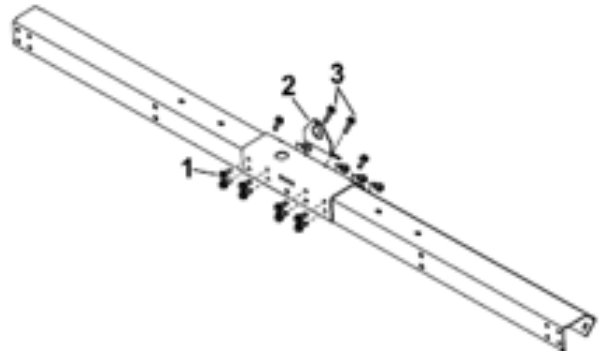

3.6. Using a bench vice (or multiple pipe wrenches) and thread sealant, thread together the *84" Boom Pipe Drivers Side* and *84" Boom Pipe Passenger Side* utilizing the *Boom Stainless Steel Coupling*. **Take care to ensure that all holes in the boom pipes are aligned in the same orientation.**

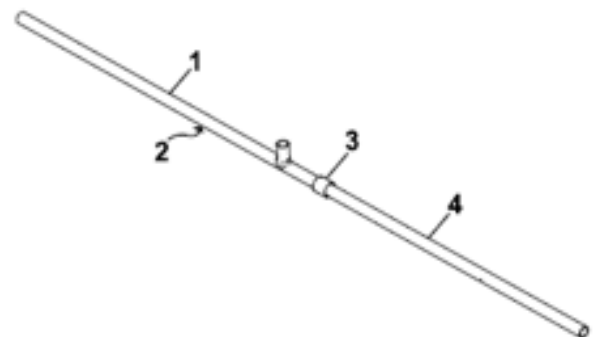

3.7. Insert the assembled boom pipe into the boom shrouds, lining up the riser with the hole in the middle of the shroud. Then install the *84" Boom Shroud Drivers Side* in a manner similar to Step 4 previously.

3.8. Using a pipe wrench and thread sealant, thread the *Boom Pipe Caps (CAP100)* on each end of the exposed boom pipe. **Be careful to not overtighten to avoid cracking.**

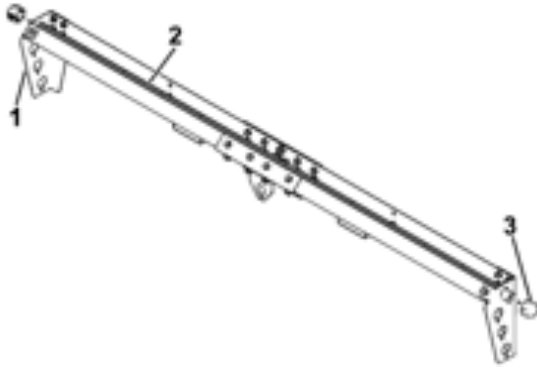

3.9. Using a pipe wrench and thread sealant, thread the *Male Camlock Coupler (100A)* onto the top of the exposed boom pipe riser. **Be careful to not overtighten to avoid cracking.**

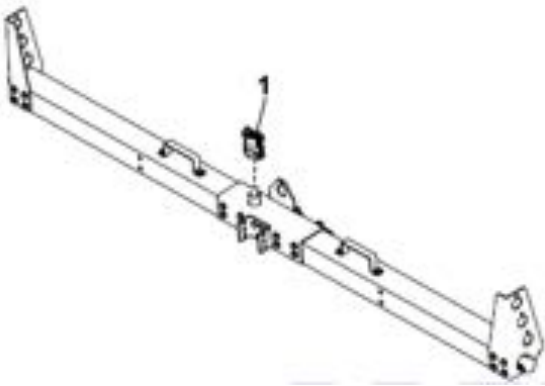

3.10. Install the *Center Fan Boom Nozzle* fed from the outside towards the mass of the boom, fastening with hex bolt ( $3/8" \times 1 \frac{1}{4}"$ ), washers, and lock nut. Install the *Large Side Boom Spray Nozzle (Qty: 2)*, the *Medium Side Boom Spray Nozzle (Qty: 2)*, and the *Small Side Boom Spray Nozzle (Qty: 2)* fed from the outside towards the mass of the boom, fastening with hex bolt ( $3/8" \times 1 \frac{1}{4}"$ ), washers, and lock nut. The largest nozzle should be in

the highest position and the smallest nozzle should be in the lowest position.

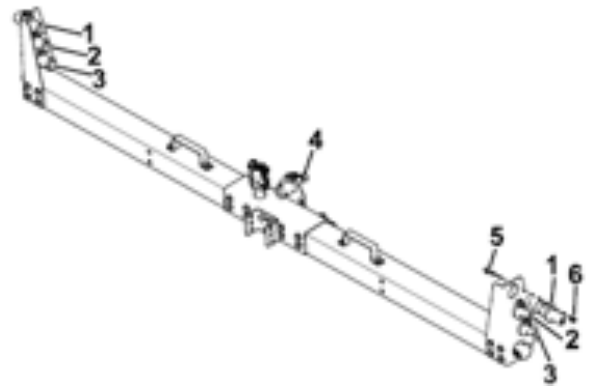

3.11. Install the *Boom Hitch Receiver* to the *Boom Side Height Adjustment Bracket*, fastening with hex bolts ( $1/2" \times 4 \frac{1}{4}"$ ), washers, and locknuts. This hitch receiver is adjustable so that the boom pipe is approximately 18" to 24" off the ground when installed on the truck. Adjust mounting height as necessary.

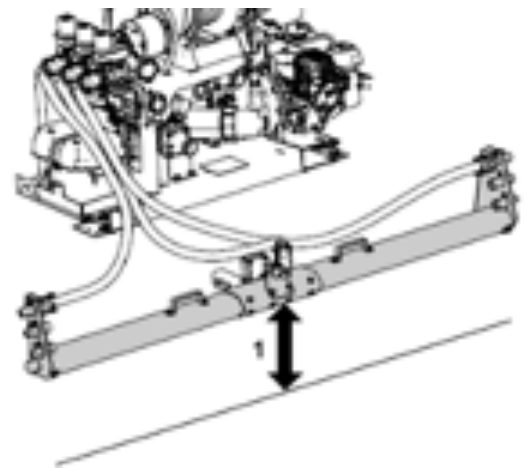
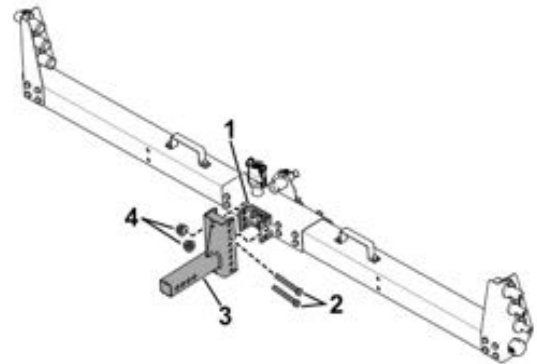

## 4. Assemble and Install Boom Hoses

- 4.1. Hold the 1" EPDM Rubber Hose (Qty: 25) from the electric solenoid valve position to boom nozzle to ensure proper length. Cut the hose section as needed.

Note: when looking at the electric solenoid valves, the left-most valve (#1 in Figure) should connect to the driver side boom nozzle, the middle electric solenoid valve (#2 in Figure) should connect to the center of the boom, and the right-most electric solenoid valve (#3 in Figure) should connect to the passenger side boom nozzle.

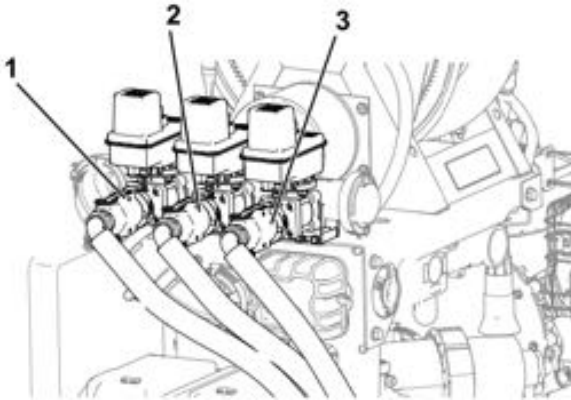

- 4.2. Using the hose clamps insert and fasten the camlock hose barbs into the cut hoses.

Note: the driver side boom hose should have one (1) 1" *Straight Barb Camlock Coupler (100C)* and one (1) 1" 90° *Barb Camlocks (100D with HB100-90)*. The center boom hose should have two (2) 1" 90° *Barb Camlocks (100D with HB100-90)*. And the passenger side boom hose should have one (1) 1" *Straight Barb Camlock Coupler (100C)* and one (1) 1" 90° *Barb Camlocks (100D with HB100-90)*.

- 4.3. Connect the assembled boom hoses to the electric solenoid valves and boom nozzles using the camlocks.

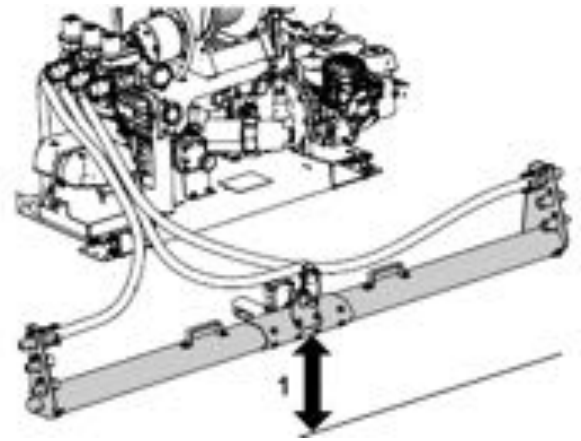

## 5. Connect to Sprayer Via Bluetooth

To begin using the machine, you must first download the **VSI Spray Control App** from either the Apple App store or Google Play store onto your phone or tablet.

- 5.1. Ensure the sprayer engine key is in the ON position.

**Note:** The engine key can remain in this ON position all the time without draining the battery.

- 5.2. Once downloaded, open the app, read the liability prompt, press *OK*, and click on the **DETAILS** tab on the bottom of the app screen.

- 5.3. Turn on the power switch on the sprayer control box. As the circuit board starts up you will hear relays clicking. If you do not hear this and there are no lights on inside the box please check your battery for sufficient charge. After a few seconds press the "Connect" button on your phone.

**Note:** An LED on the computer inside the box will indicate the charge level of the battery on the sprayer; Green (Full), Yellow (Half), and Red (Low).

- 5.4. All sprayers within Bluetooth range will appear. Select the sprayer you are wanting to connect to (The default name is the serial number of the sprayer).

**Note:** The serial number can be found on the side of the control box.

5.5. The app is now connected to the sprayer and has control over the unit.

**Note:** No other devices can connect to a unit that is actively paired to a device.

5.6. If desired, rename the sprayer through the **DETAILS** page in the app.

## 6. Connect Sprayer to WiFi

The sprayer uses WiFi to search for new firmware releases that may come out to increase performance and reliability of the system. The sprayer will search for active WiFi networks once per day for 5 minutes. If the sprayer has already recently connected to the WiFi, is in range of WiFi, and if an update is available the sprayer will automatically update.

Connect to WiFi after you first purchase the sprayer. You can also do a prompted connection at any point in time by following these connection steps:

6.1. Ensure you are already connected to the sprayer via Bluetooth connection.

6.2. Click on the **STATUS** tab at the bottom of the app screen. Connect the sprayer to the nearest WiFi to where the sprayer will be stationed or most often parked.

6.3. If you know the network credentials they can be entered manually. Otherwise you can select **SCAN FOR WIFI NETWORKS**. A list of available networks will be displayed.

**Note:** The sprayer can only connect to **2.4GHZ** networks, **5G** networks are **not** compatible.

6.4. Select the network that you wish to connect and enter the password for the network. Verify the security setting of the network. You will be prompted with either a successful connection or a failed connection. The sprayer will store the credentials for the last ten (10) WiFi connections entered.

## 7. Pair Remote to Sprayer

7.1. On the remote, press and hold the power button to turn on the remote.

**Note:** A light will be displayed which will indicate the charge level of the remote; Green (Full), Yellow (Half), and Red (Low).

7.2. With a smartphone and tablet connected to the sprayer via Bluetooth, go to the **STATUS** page on the app and select **PAIR WITH REMOTE**. If this button is not showing first select **SCAN FOR WIFI NETWORKS**. Follow the onscreen instructions after hitting **PAIR WITH REMOTE**.

7.3. The app will ask you to hold down the **RUN/HOLD** button on the remote for five (5) seconds until the pairing is verified. If pairing fails, repeat this procedure.

Once the remote is paired, it will be connected to the serial number of the sprayer that was used to connect. Remotes can be interchanged by going through this pairing procedure again.

## 8. Install the Antenna

8.1. Attach the antenna to the antenna mount. Unscrew the nut from the antenna. Put the threaded end of the antenna through the mount. Screw the nut back on the antenna to secure it to mount.

8.2. Connect one end of the coaxial to the bottom of the sprayer control box.

8.3. Route the cable to the driver's side of the machine and as close to the driver's cab as possible.

8.4. Connect the other end of the coaxial cable to the antenna.

8.5. Connect to the sprayer and check the BLE RSSI signal strength. Adjust positioning of antenna as needed to maximize signal strength.

# Product Overview

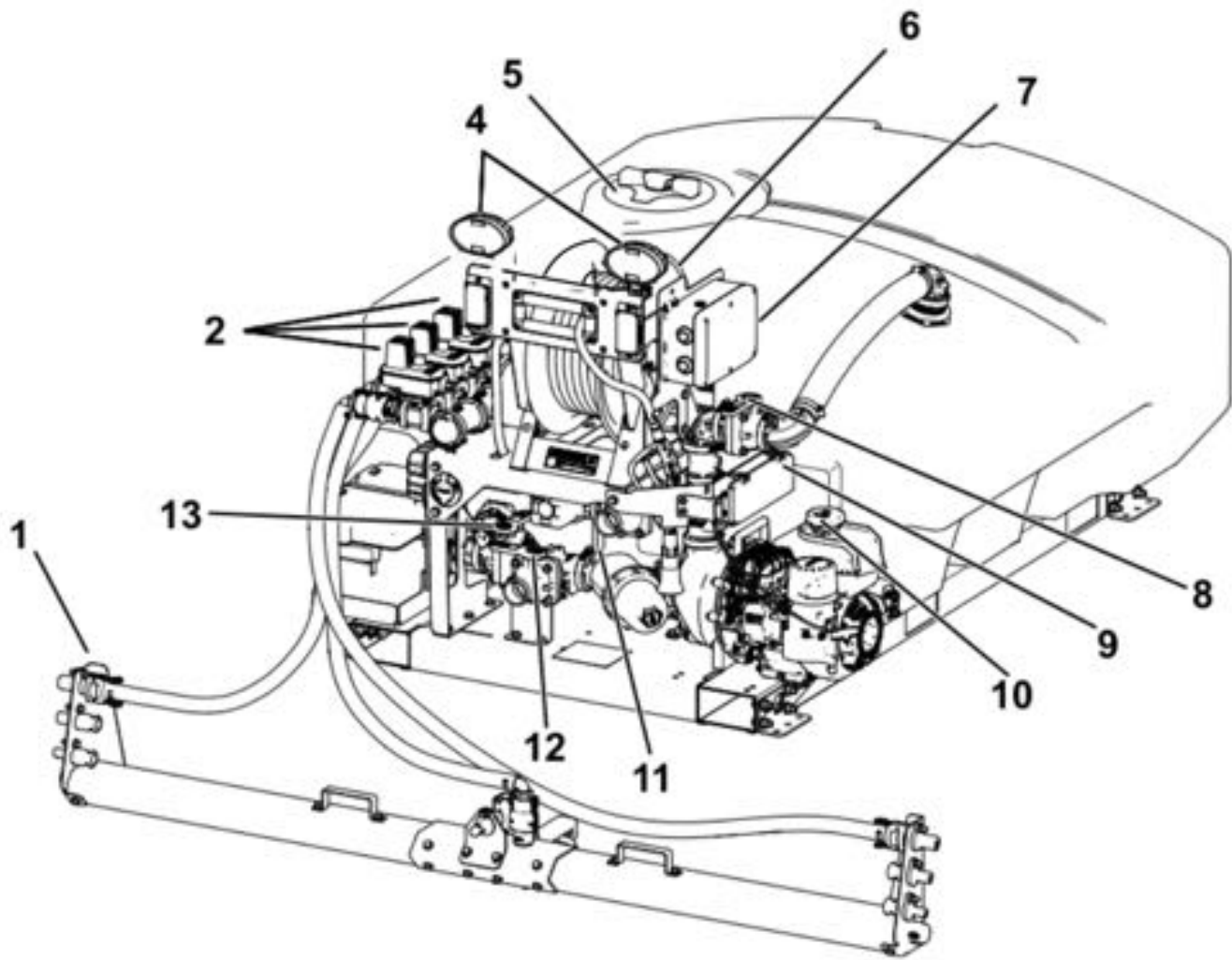

- 1. Pile Driver Boom
- 2. Electric Boom Valves
- 4. Work Lights
- 5. Tank Cover
- 6. Hose Reel
- 7. Sprayer Control Box

- 8. Bypass Valve
- 9. Total Control Box
- 10. Fuel Cap
- 11. Pump-Out Valve
- 12. Fill Valve
- 13. Tank Valve

## Pile Driver Boom

The three-lane Pile Driver Boom offers the ability to spray over 30 feet wide with precision.

Each section of the boom is controlled via the VSI Spray App by pressing the *Boom Section Control* buttons the **SPRAY** tab in accordance with the boom section you want to activate/deactivate. If damage occurs to any part of the boom, contact VSI for replacement parts.

## Total Control Box

The total control box contains actuators that control the throttle and choke of the engine. It is important to keep the choke and throttle mechanisms lubricated and clean so that the total control system can function properly. Take caution not to damage the linkage cables from the box to the engine.

## Flowmeter

The flowmeter is the green device in-line with the plumbing on the pressure side of the pump. This vital instrument tracks the flow rate and volume going to the hose reel and spray boom sections. This real-time reading tells the sprayer GPS rate-control system to increase or decrease the flow rate to the boom based on your speed by opening or closing the proportioning valve. The figure below shows the flowmeter as viewed from the back of the spray unit.

**Note:** The magnetic flowmeters used do not require recalibration due to the use of different brine blends.

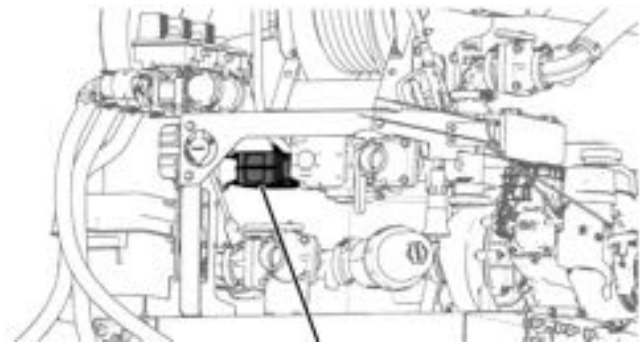

## Proportional Valve

The proportioning valve is what regulates the flow to the spray boom based on GPS speed inputs when spraying in *AUTO* mode. Or in *MANUAL* mode the proportioning valve regulates the flow to the spray boom based on user inputs for desired gallons per minute.

The figure below shows the proportional valve as viewed from the back of the sprayer. The viewing glass panel indicates full flow (arrow pointing all the way counter clockwise, 9 o'clock position) or closed (all the way clockwise, 12 o'clock position).

**Note:** Check your Proportional Valve Setting on the **SETTINGS** tab of the VSI Spray App to match the yellow or red proportional valve equipped on the sprayer.

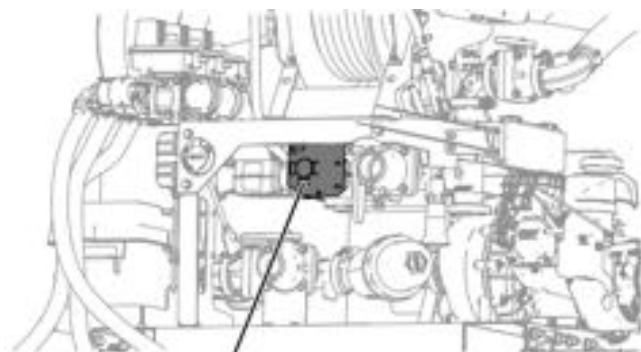

## Filter

Each sprayer is equipped with a filter right before the inlet to the pump. Inside the filter housing is a reusable stainless steel 30 mesh filter.

If you suspect the filter is clogged:

1. Close the tank valve and loosen the collar around the filter housing.
2. Pull the outer housing off and remove the filter.
3. Rinse the filter clean and place it back in the housing.

## Remote Controls Overview

The remote operates in three (3) different configurations.

1. Smartphone/tablet connected to sprayer and remote in conjunction,
2. Only remote connected to sprayer, and
3. Remote wired via emergency backup harness

### Configuration Option 1

#### Smartphone/Tablet Connected to Sprayer and Remote in Conjunction

With a smartphone or tablet connected to the sprayer via Bluetooth, the remote replaces the need to use the touch screen on your device. This configuration allows the operator a tangible feel of turning the boom sections on and off on the remote.

Normal use of this configuration consists of the smartphone or tablet mounted on a holder in the vehicle to monitor settings and the spray display; the remote is then used to signal boom sections and engine control.

**Note:** The display on the **SPRAY** tab of the VSI Spray App is identical (and updated) when using the remote or the app controls.

### Configuration Option 2

#### Only Remote Connected to Sprayer

The remote is able to control the sprayer in situations where a smartphone or tablet are not connected.

In this configuration the remote will default the sprayer settings to 100 GPA (gallons per acre) and function in the *Auto* mode.

### Configuration Option 3

#### Remote Wired Via Emergency Backup Harness

In an emergency situation (dead battery on sprayer, damaged components, smartphone issues, etc.), use the wired emergency backup configuration. The remote in this wired configuration will still signal the three (3) boom sections along with the engine throttle and choke controls. All other functions of control are disabled.

Store the emergency harness in the vehicle and install it only when needed.

Connect the harness of the ten-pin plug (located on the back of the sprayer control box) and route the cable through an open window of the truck. Plug the other end of the harness into the auxiliary power port (cigarette lighter) on the truck and plug the flat ten-pin plug into the bottom of the remote (you will need to remove the rubber plug on the bottom of the remote to access this plug).

If this emergency backup harness is connected to the box while the sprayer control box power switch is on, the control box will turn off all functions and go into sleep mode. You will not be able to operate the sprayer with a smart device until the backup harness is disconnected.



**Note:** A 10 foot extension harness is also supplied and can be used when the 25 foot harness is not long enough to reach the cab of the truck.

## Controls

The sprayer remote controls many of the same features as the VSI Spray App. With the remote you are able to control boom sections independently, utilize the Run/Hold feature, control engine throttle and choke position, electric start, engine kill switch, and rewind the hose reel.

1. Run/Hold button- prevents boom section functions from being activated unintentionally
2. Right boom valve - on/off
3. Center boom valve- on/off
4. Engine choke- up
5. Engine throttle- up
6. Hose reel rewind- momentary on
7. Engine throttle- down
8. Engine choke- down
9. Left boom valve- on/off
10. Remote power- on/off

Holding button 4 (Engine choke- up) and button 8 (Engine choke- down) together will engage the engine remote start.

Holding button 5 (Engine throttle- up) and button 7 (Engine throttle- down) together will engage the engine kill switch.



# Specifications

**Note:** Specifications and design are subject to change without notice.

Check with local laws and regulations to ensure your truck is not overloaded when equipped with a sprayer and liquid.

## Machine Specifications

Description	APB	305 LP	500 ASM	750 ASM	1000 ASM	1600 ASM
Length (inches)	25	74	102	108	110	156
Width (inches)	48	61	60	70	80	74
Height (inches)	46	43	50	57	67	63
Weight (Empty)	432	843 lbs	966 lbs	1127 lbs	1,200 lbs	2,122 lbs
Weight (Full)*	NA	4,070 lbs	6,256 lbs	9,062 lbs	11,780 lbs	19,050 lbs
Capacity	NA	305 Gal	500 Gal	750 Gal	1,000 Gal	1,600 Gal

**\*Note:** Weight when full is based on 10.58 lbs per gallon of carrying capacity. Actual weight per gallon will vary based on material carried

## Attachments and Accessories

A selection of VSI approved attachments and accessories are available for use with the sprayer to enhance and expand its capabilities. Contact VSI for further information.

To ensure optimum performance and continued safety certification of the machine, use only genuine VSI replacement parts and accessories. Replacement parts and accessories made by other manufacturers could be dangerous, and such use could void the product warranty.

# Operation

## *Before Operation*

### Before Operation Safety

#### General Safety

- Never allow children or untrained people to operate or service the sprayer. Local regulations may restrict the age of the operator. The owner is responsible for training all operators and mechanics.
- Become familiar with the safe operation of the equipment, operator controls, and safety signs.
- Shut off the engine, remove the key (if equipped), wait for all movement to stop, and allow the machine to cool before adjusting, servicing, cleaning, or storing it.
- Know how to shut off the engine on the sprayer quickly.
- Check that safety switches and shields are attached and functioning properly. Do not operate the sprayer unless they are functioning properly.
- Before operating the sprayer, inspect it to ensure that the components and fasteners are in good working condition. Replace worn or damaged components and fasteners.
- Ensure that all fluid line connectors are tight and that all hoses are in good condition before applying pressure to the system.

#### Fuel Safety

- Use extreme care in handling fuel. It is flammable and its vapors are explosive.
- Extinguish all cigarettes, cigars, pipes, and other sources of ignition.
- Use only an approved fuel container.
- Do not remove the fuel cap or fill the fuel tank while the engine is running or hot.

- Do not add or drain the fuel in an enclosed space.
- Do not store the machine or fuel container where there is an open flame, spark, or pilot light, such as on a water heater or other appliance.
- If you spill fuel, do not attempt to start the engine; avoid creating any source of ignition until the fuel vapors have dissipated.

#### Chemical Safety

Chemical substances used in the sprayer system may be hazardous and toxic to you, bystanders, and animals, and they may damage plants, soil, and other property.

- Read the information on each chemical. Refuse to operate or work on the sprayer if this information is not available.
- Verify that there is an adequate supply of clean water and soap nearby, and immediately wash off any chemicals that contact you.
- Carefully read and follow the chemical warning labels and safety data sheets (SDSs) for all chemicals used, and protect yourself according to the chemical manufacturer's recommendations.
- Always protect your body while using chemicals. Use the appropriate personal protective equipment (PPE) to guard against contact with chemicals, such as eye protection and/or face shield and chemical-resistant gloves.
- Obtain proper training before using or handling chemicals.
- Use the correct chemical for the job.
- Follow the chemical manufacturer's instructions for safely applying the chemical. Do not exceed the recommended system application pressure.
- Do not fill, calibrate, or clean the machine while people, especially children, or pets are in the area.

- Do not clean spray nozzles by blowing through them or placing them in your mouth.
- Always wash your hands and other exposed areas as soon as possible after working with chemicals.
- Keep chemicals in their original packages and stored in a safe location.
- Properly dispose of unused chemicals and chemical containers as instructed by the chemical manufacturer and your local codes.
- Follow all local, state, and federal regulations for spreading or spraying chemicals.

## Fuel Specifications

- Use unleaded (87 pump octane minimum) gasoline.
- For best results, use only clean, fresh (less than 30 days old), unleaded gasoline with an octane rating of 87 or higher ((R+M)/2 rating method).
- Ethanol: Gasoline with up to 10% ethanol (gasohol) or 15% MTBE (methyl tertiary butyl ether) by volume is acceptable. Ethanol and MTBE are not the same. Gasoline with 15% ethanol (E15) by volume is not approved for use. Never use gasoline that contains more than 10% ethanol by volume, such as E15 (contains 15% ethanol), E20 (contains 20% ethanol), or E85 (contains 85% ethanol). Using unapproved gasoline may cause performance problems and/or engine damage, which may not be covered under warranty.
- Do not use methanol or gasoline containing methanol.
- Do not store fuel either in the fuel tank or fuel containers over the off-season unless a fuel stabilizer is used.
- Do not add oil to gasoline.

## Filling the Fuel Tank

**Fuel-Tank Capacity:** 0.95 US Gallons

1. Clean around the fuel-tank cap and remove the cap from the tank.
2. Fill the fuel tank to approximately 1 inch below the top of the tank with the specified fuel.

The air space below the top of the tank allows the fuel to expand.

***Important:* Do not overfill the fuel tank. Adding more than the specified level results in damage to the vapor recovery system, leading to engine performance failure. This is not a warrantable failure and requires fuel-tank cap replacement.**

3. Install the fuel-tank cap and wipe up any spilled fuel.

## Side Boom Nozzle Positions

### Small Side Nozzles

The small side boom nozzles are located on the bottom of each boom end nozzle mount.

The small side nozzles are lower flow rate and are made for the lower application rates of typical pre-treatment.

The small side nozzles are designed to be used when spraying at 20 to 50 gallons per acre (GPA) at normal speeds of 2 to 10 mph. These tips could also be used in applications where you are post treating in very small lots, on driveways, or other low speed or low volume applications.

### Medium Side Nozzles

The medium side nozzles are located in the middle of each boom end nozzle mount.

The medium side nozzles are designed for normal post treatment applications (60 to 80 GPA) and travel speeds of 5 to 14 mph.

## Large Side Nozzles

The large side nozzles are located on the top of each boom end nozzle mount.

The large side nozzles are designed to be used when spraying 80 to 120+ GPA or when pre-treating at higher speeds around 25 mph. These nozzles would be typical on areas such as roadways or large logistics centers where speeds commonly exceed treatment speed of a typical parking lot.

**Note:** Attempting to perform a pretreatment application with the center boom pipe and small side nozzles will leave the application rate **unbalanced** and the outer nozzle performance will suffer. While center boom pipe applications leave the appearance of pretreatment “lines” similar to a highway department, the performance will be unsatisfactory. The highway department is traveling at high rates of speed, requires a heavier pattern to avoid wind dilution, and has high traffic levels to track product evenly.

## Center Boom Nozzle Positions

There are 2 available connection points on the center of the boom, the center fan nozzle and the center boom pipe.

## Center Fan Nozzle

The center fan nozzle is designed to be a pre-treatment tip only. The design of the tip allows it to cover slightly more than the width of the truck and provide an even coverage of the application surface.

**Note:** When pretreating parking lots with little traffic utilizing lower application speeds the center fan nozzle is the preferred tip.

## Center Boom Pipe Connection

The center boom pipe connection utilizes the 1” stainless steel pipe inside the boom shroud.

This connection point will be used for all post treatment applications and high speed pretreatment applications. As stated before, the center boom will not be balanced when using the small side nozzles, but this configuration can be used in areas where very slow post treatment application is required.

Normal post treatment application will consist of the center boom pipe and medium side nozzles.

# Sprayer Control Box Light Modes

The computer inside the control box will display different light modes depending on the operation status/ battery level of the sprayer.



Common light modes include the following:

Status LED Indicator	Mode and Meaning
Solid green, yellow, or red	<b>Computer is on but is not connected to Bluetooth.</b> The color of the light indicates the battery voltage that the computer is currently reading from the battery. Green is close to full charge, Yellow is medium charge, Red means the battery needs to be charged.
Breathing green, yellow, or red	<b>Computer is on and connected to a device with Bluetooth.</b> The color of the light indicates the battery voltage that the computer is currently reading from the battery. Green is close to full charge, Yellow is medium charge, Red means the battery needs to be charged.
Flashing green, yellow, or red	<b>One or more of the booms is on or Hose Reel Tracking is enabled.</b> The color of the light indicates the battery voltage that the computer is currently reading from the battery. Green is close to full charge, Yellow is medium charge, Red means the battery needs to be charged.
Flashing orange	<b>Control box is saving data to the computer. <u>DO NOT UNPLUG THE CONTROL BOX WHEN THE ORANGE LIGHT IS FLASHING OR DATA CORRUPTION CAN OCCUR.</u></b> This happens when a user disconnects a smart device connection, whether the user chooses to disconnect or the smart device goes out of range. The control box also saves data when the power button is turned off. If the power button is turned off the computer will flash orange while it saves data and then the light on the computer will turn off.
Flashing magenta	<b>Control box is receiving a firmware update.</b> It is normal for the light to appear solid for a short period of time and flash at different rates while the firmware update is being downloaded. Once the process is finished the computer will restart and the user will need to reconnect to the sprayer with their smart device.
Flashing green, then breathing cyan	<b>Operator is connecting the sprayer board to WiFi.</b> When the user chooses to connect to WiFi the computer will start flashing green as it tries to connect to the WiFi network chosen. When the network is connected the light will flash cyan until it is able to establish a connection with the cloud. Then when it connects to the cloud it will start breathing cyan. If there is a firmware update available the

	computer will start downloading it and the color will change to Magenta. If the computer does not change from flashing green it could mean that an incorrect password was entered, or the network uses some security measures that don't allow the computer to connect to the internet.
No status LED indicator	<p>If there is no light coming from the computer it could be the following scenarios:</p> <ul style="list-style-type: none"> <li>● Power button is turned off and the computer is off. Turn the power button on to turn the computer on.</li> <li>● If the Emergency Backup Harness is plugged into the back of the control box the sprayer will not turn on with the power switch. Please unplug the Emergency Backup Harness and power cycle the control box to turn on the computer.</li> <li>● If the light never turns on check the following: <ul style="list-style-type: none"> <li>○ Fuses underneath the battery cover to see if there is a blown fuse.</li> <li>○ Battery voltage level. Sprayer will not stay on if the battery voltage is under 9VDC.</li> <li>○ Harness power connections from the battery to the control box.</li> </ul> </li> </ul>

The computer inside the control box will also display different light modes to indicate power status to the circuit board. These lights are separate from the LED light indicators above.

Status LED Indicator	Mode and Meaning
Small Blue LED	<b>Signal received from power switch to turn on sprayer board.</b>
Small Orange LED	<b>LiPo battery is charging.</b> The sprayer control box includes a LiPo battery to allow the computer to save data without corruption even in the event of a sudden disconnect or main system power loss. While the orange light is displayed the LiPo battery is charging. This light will turn to blue once the battery is fully charged.

# Navigation the VSI Spray Control App

## Status Tab

The **STATUS** tab is used to search and connect to WiFi networks. Reference the *Connecting to WiFi* section of the manual. The **STATUS** tab will also display the Product ID, Product Version, and app version that are currently configured and installed.

Product version relates to the firmware version of the sprayer and will be used frequently in diagnosing and troubleshooting. VSI customers will be notified when new firmware versions are available for download.

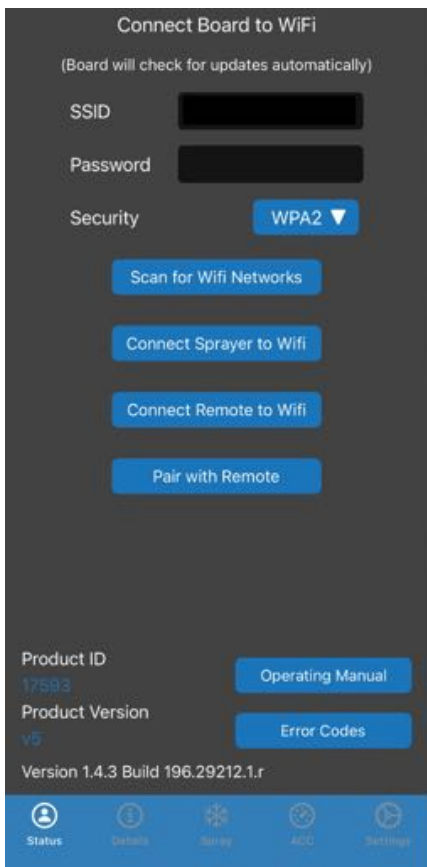

**Error Codes:** This button will allow the user to view the latest error codes from the sprayer. Each error includes a priority level, date and time of error, firmware version, battery voltage, BLE and RF RSSI,

last reset reason, as well as other data relevant to the sprayer and error.

## Details Tab

The **DETAILS** tab contains the job tracking, event tracking, season tracking. It also contains the total amount of liquid applied and engine hours. These numbers are retained by the control system on the sprayer and reflect the usage of the system.

Click the **CONNECT** button in the **DETAILS** tab to connect to the sprayer.

**Note:** There is a dropdown menu to select Sprayer or BrineMix depending on which machine you are attempting to connect. Leave on the Sprayer setting to connect to your machine (see owner's manuals for brine mixers to utilize the other option).

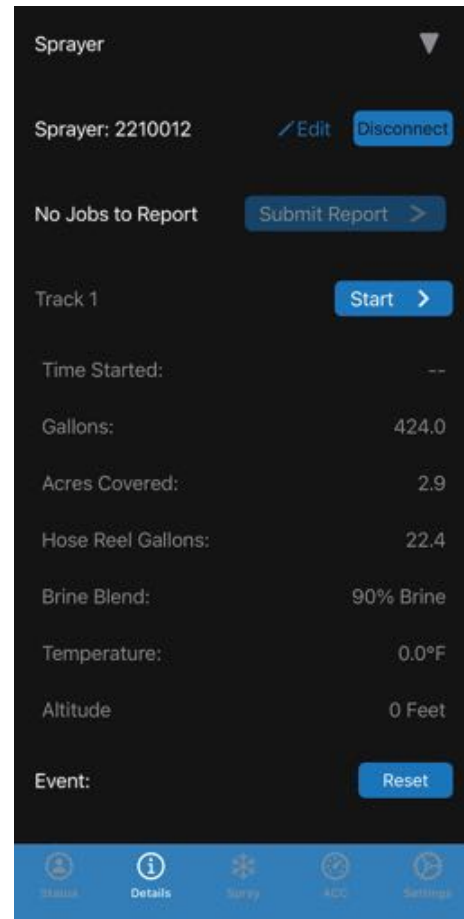

**Job Tracking/Reporting:** The first option you will see is the built in job tracking display. This can be used



when information is needed specific to billing for work completed. To start tracking a job select *START*. You will be asked to name the job if you prefer and then select *OK*. All information will be recorded while spraying or using the hose reel. Once the job is complete, select *STOP*. The job is then saved until the user is ready to submit the report.

When the user selects the *SUBMIT REPORT* button, the user will be prompted to supply an email address to which the report will be sent. Additional notes may be added at this time as well. The report will be emailed as a CSV file and can be opened to view all recorded data.

**Event:** Event tracking can be useful to record information pertaining to a single event. This can be helpful when tracking production times and efficiencies of vehicles and operators. To clear all information, press the *RESET* button.

**Season:** Season tracking functions the same as event tracking. More information will be displayed such as average GPA (gallons per acre). To reset all information, press the *RESET* button.

**Note:** The Event and Season tracking will continuously count unless the tracking is Reset.

**Serial Number:** Displays the serial number of the sprayer submitting the job report.

**Total Gallons Sprayed:** Displays the total lifetime gallons sprayed while being controlled by that connected circuit board.

**Engine Hours:** Displays the total lifetime engine hours while being controlled by that connected circuit board.

**Last Disconnect Reason:** The reason for the last disconnection of the Bluetooth signal will be displayed. Possible messages include: Power switch turned off, Lost 12V power, Emergency backup plugged in, Sprayer connection timeout.

## Spray Tab

The **SPRAY** tab of the app is where all functions of the application process are controlled.

Vital system information is displayed on the top lines in the **SPRAY** tab in the app. This information includes the sprayer name/serial number that is connected, system voltage, ground speed, satellite connecting, BLE RSSI (Bluetooth signal strength), RF RSSI (VSI Remote signal strength), and the ambient temperature. Below the heading bar you will find the switches to signal the LED work lights and strobes.

The work lights, strobe lights, and operation mode switches are located below the vital system information in the **SPRAY** tab.

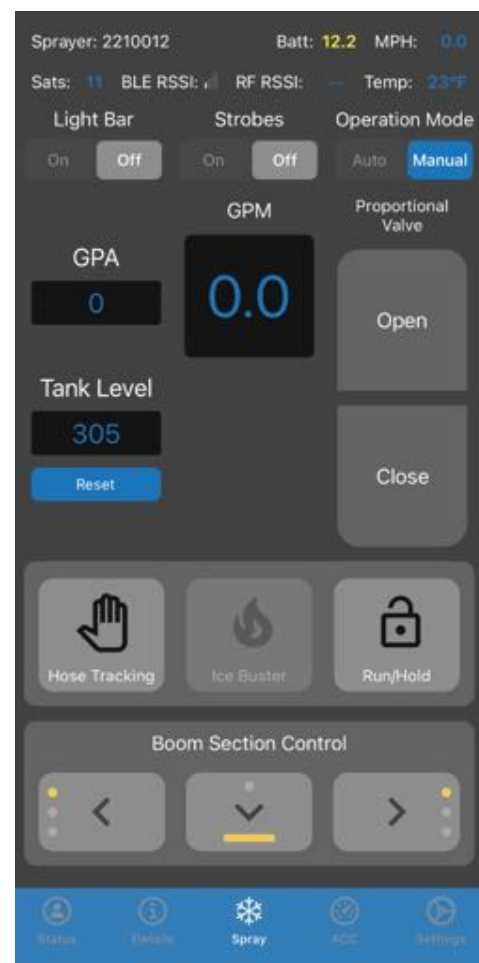

**Reset:** This button resets the tank level to full capacity. See the *TANK LEVEL* section on the

**SETTINGS** tab information later in this manual to set the tank size.

## Operation Modes

**Auto Mode:** When in *AUTO* mode, you will be able to change the *App Rate*, which always defaults to 80 gallons per acre (GPA). The + and – buttons will adjust the GPA by 5 up or down for each press. The sprayer will automatically control the flow of solution to apply the desired application rate based on travel speed and spray width. The system will automatically close all valve sections when the application vehicle has come to a complete stop and open all signaled valve sections once the vehicle begins moving again.

**Note:** If the application vehicle is not moving the valves will not open when signaled in Auto mode. This is normal and yields no cause for concern.

**Note:** When in *AUTO* mode, the engine will automatically throttle for maximum operating performance to 100% throttle while spraying and 50% throttle while in *RUN/HOLD* mode or when the sprayer is not in motion.

**Manual Mode:** When in *MANUAL* mode, the readout changes from *App Rate* to *GPM* (gallons per minute). By holding open or close, you will be allowing more or less liquid GPM to flow through and be applied out of the selected boom sections. *MANUAL* mode is most often used in tight areas where slow application speeds are required. By using manual mode, the user is able to set a higher flow rate to help cut through snow pack and ice. The valves can be opened at any time in manual mode whether the application vehicle is stationary or moving.

**Hose Tracking:** *HOSE TRACKING* is selected when using the hose reel and it tracks the gallons applied through the hose. When selected, the engine will automatically adjust to 100% throttle and the proportioning valve will fully open allowing the most flow to be present when using the hose reel. When deselected, the engine will return to the previously set engine speed. It is recommended the user clicks this

button each time the hose reel is used, even if you are not tracking the amount of liquid applied

**Ice Buster:** The *ICE BUSTER* button is used when you are spraying a steady rate but have a section of snowpack, ice, or a high priority area that needs a higher application rate for a short stretch. By pressing this button, the boom sections will put out a predetermined rate that will be higher than the standard application rates. This predetermined rate can be changed in the **SETTINGS** tab. Once deactivated, the system returns to the set rate in *AUTO* mode. The *ICE BUSTER* feature is disabled in *MANUAL* mode, switch to *AUTO* mode if desired to use.

**Run/Hold:** The *RUN/HOLD* button activates or deactivates all boom sections that are currently activated. This is especially useful in situations where all 3 boom sections are being used and need to be turned off at the same time. Press the *RUN/HOLD* button to shut off all booms and press again to turn all sections back on. This can be used for any boom configuration. You may also choose to put the booms on *HOLD* while traveling between jobs to prevent the sections from accidentally being activated.

**Boom Section Control:** The *BOOM SECTION CONTROL* buttons are at the bottom of the **SPRAY** tab. These control the left, center, and right nozzles.

**Note:** Proper tip selection is indicated based on the application rate the user has selected. Indicators on the boom section buttons will light up to the corresponding nozzles on the boom to inform the user of the suggested tip for their application rate.

**Note:** The boom sections will fault and automatically shut off if an open circuit or short circuit is detected. Repeated automatic shut off of the boom sections is an indication of a fault in the boom section.

## ACC Tab

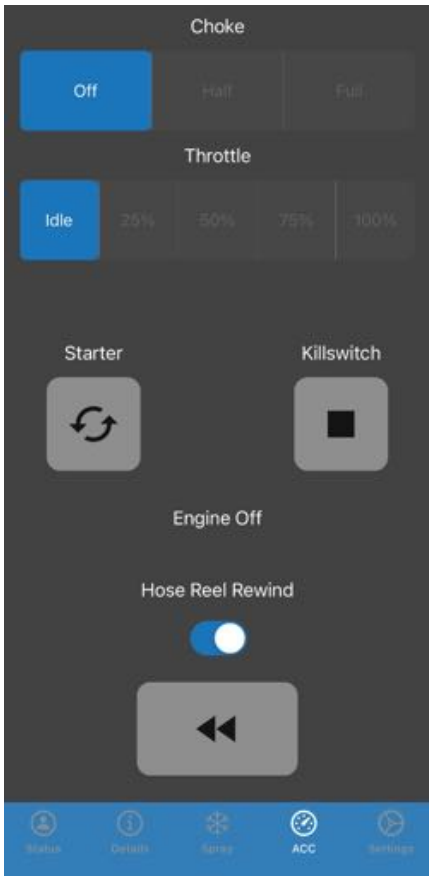

**Throttle and Choke Control:** The throttle and choke are controlled by selecting the adjustment tabs on the **ACC** tab in the app. Choke positions of 0% (off), 50% (half), and 100% (full) can be selected. Throttle positions function in the same way, 0% (idle) through 100% (WOT).

**Engine Starter:** Press and hold the *STARTER* button on the app to start the machine's engine. Once the engine is running, stop pressing the button.

**Note:** The starter will stay engaged while the operator is holding the button. There is a timer that will stop the starter after 5 seconds on consecutive button holding. If cranking times of longer than 5 seconds are required, activate the starter button again.

**Engine Stop:** Press the *KILLSWITCH* button to shut off the engine.

**Note:** The *STARTER* button will not engage if the *KILLSWITCH* function is active. The lights will flash five (5) times if this condition is encountered.

**Note:** The engine will automatically shut off if there is an over-voltage scenario where the battery voltage is exceeding 15.5 volts.

**Hose Reel Rewind Control:** Press and hold the *HOSE REEL REWIND* button to rewind the hose. Use the toggle feature to disable this feature while spraying so that the hose reel is not accidentally activated.

**Note:** The *HOSE REEL REWIND* button will turn off after being held for 5 consecutive seconds. If additional rewinding is needed, release the button and re-engage.

**Note:** The hose reel is protected by current monitoring and will turn off after a certain current draw threshold. If the hose becomes caught underneath an obstruction the current draw could become too high for the system and the hose reel will shut off. The user should release the button, correct the hose obstruction, and press the button again.

## Settings Tab

**Note:** Most of the app settings should be left alone unless you have consulted with your VSI distributor first.

**Note:** If needed, tap the *RESET TO DEFAULTS* button at the bottom of the app to reset the settings to factory defaults.

**Note:** Ensure to tap the *SAVE* button after any settings or tank resets.

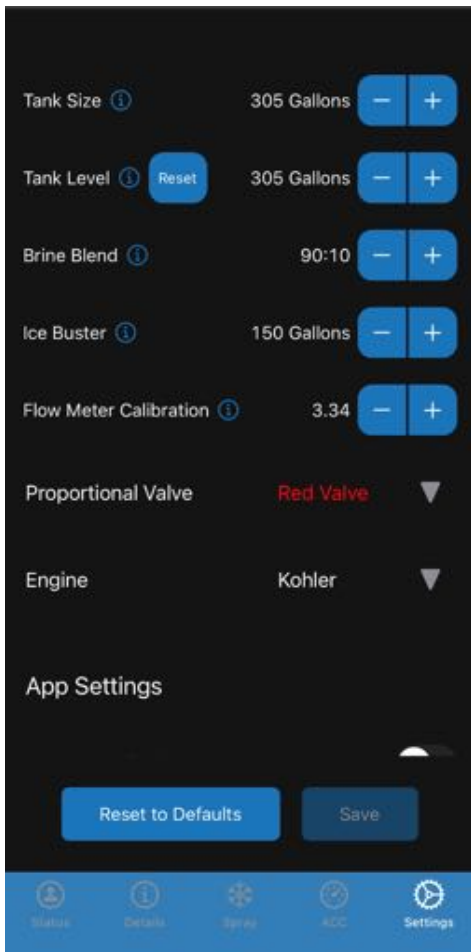

## Understanding Sprayer Valve Positions

Proper valve positioning is vital to the sprayer working correctly for each given task.

### Suction-Side Valves vs. Pressure-Side Valves

**Suction-side valves:** Any valves on the machine that are entering the lower portion of the pump housing.

**Pressure-side valves:** Any valves on the machine that are high up or connected to the top portion of the pump housing.

### Application Mode Valve Position

Set the valves in application mode position when you are applying liquid deicer. The figure below shows the valves in application mode positioning.

**Note:** The most common error that is made in application mode is that the bypass valve gets left open. This will use the majority of the pressure and liquid flow for the system and does not leave enough for the sprayer or hose reel to work properly.

**Note:** The next most common mistake is that the tank valve gets left closed. With no liquid getting to the pump, the system does not function and eventually burns out the pump seal.

**Tank Level:** The tank level needs to be reset every time the sprayer is filled up. To reset the tank level, press the *RESET* button and then select the *SAVE* button before exiting the **SETTINGS** tab. An operator can also adjust the volume using the up and down buttons if a different volume is desired.

**Brine Blend:** Brine blend can be set to whatever blend the sprayer is running. This helps track this information for job reports for job costs/margin tracking.

**Tank size, Flowmeter Calibration, Proportional Valve, and Engine** settings should be left alone unless otherwise noted.

**Ice Buster:** The ice buster setting allows you to set the desired application rate when using the *ICE BUSTER* mode in the **SPRAY** tab in the app.

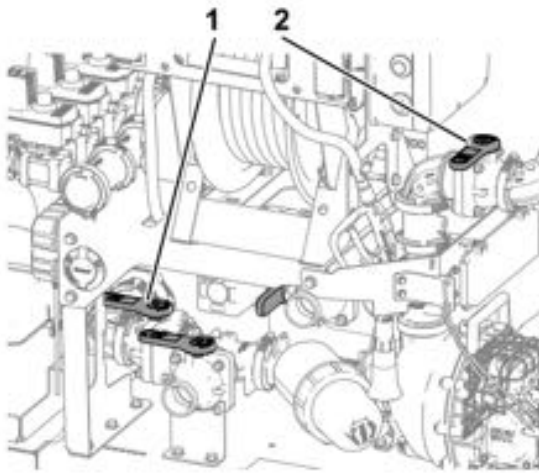

1. Tank valve                      2. Bypass valve

**Application Mode Valve Position Shown Above**

**Self-Fill Mode Valve Position**

The hose must be connected to the bottom left camlock and the valves need to be in the configuration shown in the figure below when you are using the pump on the sprayer to self fill from a holding tank.

**Note:** A common mistake is that the tank valve gets left open, this won't allow the pump to prime as it will be sucking air from the tank.

**Note:** The other common mistake when self filling is that the bypass valve gets left closed. The system will still fill this way as the valve has a hole that allows constant flow through the valve even when closed (to protect the pump from being deadheaded) but it will take an exceptionally long amount of time through that bypass.

If the tank you are pulling liquid from is lower than the height of the pump, you may have to prime the pump by unscrewing the top cap on the pump and allowing the air out of the system. In some cases you may need to fill the pump housing with liquid to purge the air fully. Most of the time when filling from a bulk storage tank, this is not an issue, especially if the fill hose is pre-charged with liquid.

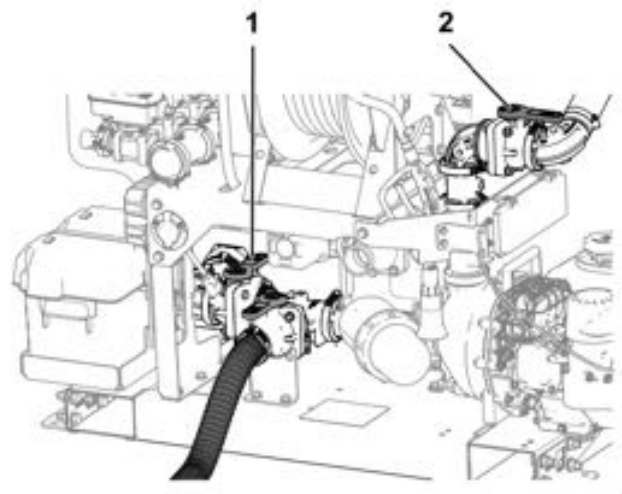

1. Tank valve                      2. Bypass valve

**Self-Fill Mode Valve Position Shown Above**

**Pump-Out Mode Valve Position**

Your tank must have liquid in the tank. The hose must be connected to the top right camlock and the valves need to be in the configuration shown in the Figure below when you are using the pump to transfer liquid from the sprayer to another tank outside of the sprayer.

**Note:** A common mistake is that the bypass valve gets left open. This will still allow the pump-out to work, but it will be substantially slower than if it is set up properly as shown.

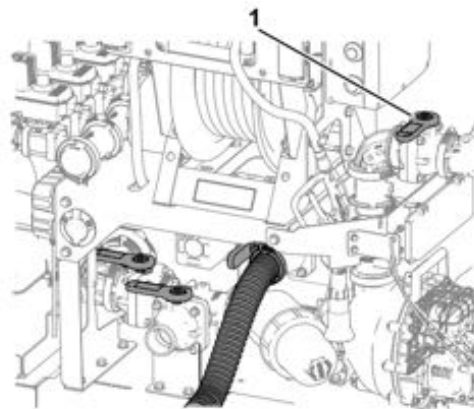

1. Bypass valve

**Pump-Out Mode Valve Position Shown Above**

# ***During Operation***

## **During Operation Safety**

- The owner/operator can prevent and is responsible for accidents that may cause personal injury or property damage.
  - Wear appropriate clothing, including eye protection; substantial, slip-resistant footwear; and hearing protection. Tie back long hair and do not wear loose clothing or loose jewelry.
  - Wear appropriate personal protective equipment as directed in Chemical Safety.
  - Use your full attention while operating the machine. Do not engage in any activity that causes distractions; otherwise, injury or property damage may occur.
  - Do not operate the machine while ill, tired, or under the influence of alcohol or drugs.
  - Operate the machine only in good visibility.
  - Use care when approaching blind corners, shrubs, trees, or other objects that may obscure your vision.
  - Before backing up, look rearward and ensure that no one is behind you. Back up slowly.
  - Never spray while people, especially children, or pets are nearby.
  - Do not operate the machine near drop-offs, ditches, or embankments. The machine could suddenly roll over if a wheel goes over the edge or if the edge gives way.
  - Reduce the speed when operating on rough terrain, uneven ground, and near curbs, holes, and other sudden changes in terrain. Loads may shift, causing the machine to become unstable.
  - Stop the machine, shut off the engine, remove the key, engage the parking brake, and inspect for damage after striking an object or if there is an abnormal vibration in the machine. Make all necessary repairs before resuming operation.
  - Slow down and use caution when making turns and crossing roads and sidewalks with the machine. Always yield the right-of-way.
- Use extra caution when operating the machine in adverse weather conditions, at higher speeds, or with a full load. Stopping time and distance increase in these conditions.
  - Do not touch the engine or muffler while the engine is running or soon after it has shut off. These areas may be hot enough to cause burns.
  - Shut off the engine, remove the key (if equipped), wait for all movement to stop, and allow the machine to cool before adjusting, servicing, cleaning, or storing it.
  - Never run an engine in an area where exhaust gasses are enclosed.
  - Use accessories and attachments approved by VSI only.

## **Starting the Engine**

1. Ensure that the spark-plug wire is connected to the spark plug.
2. Ensure that the fuel-shutoff valve is in the *OPEN* position.
3. Ensure that there is liquid in the tank.

**Important:** Running the engine without liquid in the tank may cause damage to the pump seal and pump housing. Pump seal damage from running the motor without liquid is **not** a warranty claim. To avoid this problem ensure to not run the engine while having your tank valve open. Also avoid running your tank completely dry.

4. With your phone or tablet connected to the sprayer, select the **ACC** tab in the app.
5. If the engine is cold, select *FULL CHOKE* and *75% THROTTLE*. Allow a few seconds for the choke actuator to move to full choke position.
6. Press the *STARTER* button.
7. Once the engine is running, select *HALF CHOKE* and allow the engine to warm.
8. When the engine is warm, select *CHOKE OFF* and select the desired engine throttle.

**Note:** Normal application requires that the engine throttle be set at 75% or 100%.

## Using the Sprayer

1. With your phone or tablet connected to the sprayer, select the **SPRAY** tab in the app.
2. Ensure that the battery voltage is displayed in green and the satellite connection has been established.
3. Select the desired mode (*AUTO* or *Manual*). Refer to the manual for an explanation of each mode.
4. If *AUTO* mode is selected, verify your application rate. Press the +/- buttons to make any changes.
5. If *MANUAL* mode is selected, a boom section must be open in order to see the flow read out. Press the *OPEN/CLOSE* buttons to make changes to flow.
6. Begin moving and signal the desired boom section(s) to open. You will see liquid flowing from the boom.

## Auto Mode Display

While spraying in *AUTO* mode, the display of GPA will be showing the instantaneous rate which is being applied. This number **will** change as travel speed increases or decreases. The GPA will be locked to the set rate under normal conditions. You will see the flow to the boom increase and decrease as the speed changes, especially on the boomless nozzles spray pattern. Continue spraying until the desired area has been covered.

**Note:** When driving at slow speeds the spray system will maintain a minimum flow amount. This system override of the entered GPA will prevent an under performing volume of liquid with a poor spray pattern. The app will display **MAIN** (which stands for maintain performance) in the GPA display.

## Manual Mode Display

While spraying in *MANUAL* mode, the display of GPM (gallons per minute) flowing out of any boom section will be showing. To set the GPM, open the desired boom section and use the +/- keys to change the flow rate. The sprayer will hold this flow rate until there is a manual change to the flow rate.

The rate in GPA is also displayed to the left of the screen. This can be helpful as an instantaneous readout of what is being applied will be shown. Use this to gauge the flow rate (GPM) that you desire. Application rates (GPA) of 250+ are unnecessary and the flow rate could be reduced.

Continue spraying until the desired area is covered.

## Switching Between Auto Mode and Manual Mode

You can switch between *AUTO* and *MANUAL* mode at any point during the spraying process.

If the user is going from *AUTO* to *MANUAL* mode, the sprayer will hold the last position of the servo and the flowrate (GPM) will be displayed.

If the user is switching from *MANUAL* to *AUTO* mode, the sprayer will adjust as needed to match the set application rate (GPA).

## After Operation

### After Operation Safety

- Shut off the engine, remove the key (if equipped), wait for all movement to stop, and allow the machine to cool before adjusting, servicing, cleaning, or storing it.
- Keep all parts of the machine in good working condition and all hardware tightened.
- Replace all worn, damaged, or missing decals.

# Maintenance

**Important:** Refer to your engine owner’s manual for additional maintenance procedures.

## ***Recommended Maintenance Schedule(s)***

<b>Maintenance Service Interval</b>	<b>Maintenance Procedure</b>
After the first hour	<ul style="list-style-type: none"> <li>• Charge the battery</li> <li>• Inspected the tank straps for proper attachment</li> </ul>
After the first 20 hours	<ul style="list-style-type: none"> <li>• Change the engine oil</li> </ul>
Before each use or daily	<ul style="list-style-type: none"> <li>• Check the engine-oil level</li> <li>• Check the air cleaner</li> <li>• Inspect the tank straps for proper attachment</li> <li>• Wash the machine after each use</li> </ul>
After each use	<ul style="list-style-type: none"> <li>• Charge the battery</li> </ul>
Every 50 hours	<ul style="list-style-type: none"> <li>• Clean the air cleaner (more often in dirty or dusty conditions)</li> </ul>
Every 100 hours	<ul style="list-style-type: none"> <li>• Change the engine oil</li> <li>• Check/adjust the spark plug</li> <li>• Clean the sediment cup</li> </ul>
Every 200 hours	<ul style="list-style-type: none"> <li>• Inspect all hoses and connections for damage and proper attachment</li> </ul>
Every 300 hours	<ul style="list-style-type: none"> <li>• Replace the paper element</li> <li>• Replace the spark plug</li> </ul>
Before storage	<ul style="list-style-type: none"> <li>• Grease and cap all connection points</li> <li>• Rise the sprayer tank</li> <li>• Drain the pump</li> <li>• Condition the spray system</li> <li>• Charge the battery</li> <li>• Disconnect power</li> </ul>

## **Maintenance Safety**

- Shut off the engine, remove the key (if equipped), wait for all movement to stop, and allow the machine to cool before adjusting, servicing, cleaning, or storing it.
- Allow machine components to cool before performing maintenance.
- Allow only qualified and authorized personnel to maintain, repair, adjust, or inspect the machine.
- Before performing any maintenance, thoroughly clean and rinse the sprayer; refer to *Chemical Safety* in the manual.



- Chemicals used in the sprayer system may be hazardous and toxic to you, bystanders, animals, plants, soils, or other property.
  - Carefully read and follow the chemical warning labels and safety data sheets (SDSs) for all chemicals used, and protect yourself according to the chemical manufacturer's recommendations.
  - Always protect your skin while you are near chemicals. Use the appropriate personal protective equipment (PPE) to guard against contact with chemicals, including eye protection and/or face shield, chemical-resistant gloves, and substantial footwear.
  - Refuse to operate or work on the sprayer if chemical safety information is not available.
  - Do not fill, calibrate, or clean the machine while people, especially children, or pets are in the area.
  - Do not clean spray nozzles by blowing through them or placing them in your mouth.
  - Always wash your hands and other exposed areas as soon as possible after working with chemicals.
- To ensure that the entire machine is in good condition, keep all hardware properly tightened.
- To reduce the potential for fire, keep the engine area free of excessive grease, chemicals, grass, leaves, and dirt.
- If you must run the engine to perform a maintenance adjustment, keep your hands, feet, clothing, and any parts of your body away from the engine and any moving parts. Keep everyone away.
- If the machine requires a major repair or you need technical help, contact an authorized VSI distributor.
- Modifying this machine in any manner may affect machine operation, performance, durability, or its use, and result in injury or death.

- Carefully release pressure from components with stored energy.

## Lubrication

### Lubricating the Machine

**Service Internal:** Before storage.

Use dielectric grease on all connection points and ensure to cap them.

## Engine Maintenance

The **DETAILS** tab on the app will show the total gallons sprayer and the engine hours of the spray unit. These figures can aid in reviewing maintenance schedule activities.

### Engine Safety

- Shut off the engine before checking the oil or adding oil to the crankcase.
- Do not change the governor speed or overspeed the engine.

### Engine Oil Specification

**Type:** API service classification SL or higher.

**Viscosity:** Select the oil viscosity according to the ambient temperature; refer to the figure below.

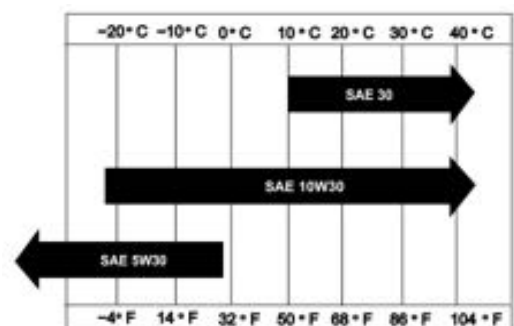

# Checking the Engine-Oil Level

**Service Interval:** Before each use or daily.

**Note:** The best time to check the engine oil is when the engine is cool before it has been started for the day. If it has already been run, allow the oil to drain back down to the sump for at least 10 minutes before checking it.

1. Clean the area around the oil-filter cap.
2. Remove the oil-filter cap by rotating it counterclockwise.

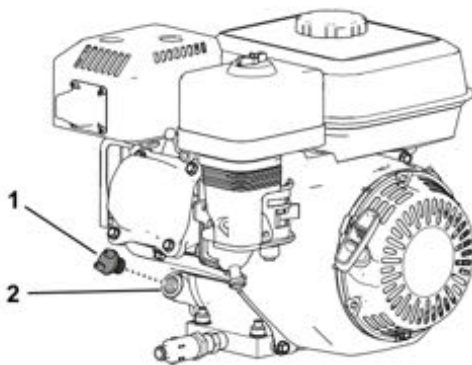

1. Oil-filler cap      2. Filler port

3. Check the oil level.

The engine is full of oil when the oil level is at the bottom edge of the oil-fill port.

**Note:** If the oil level is below the bottom edge of the oil-fill port, add enough of the specified oil to raise the level to the bottom edge of the oil-fill port.

**Important:** Do not overfill the crankcase with engine oil.

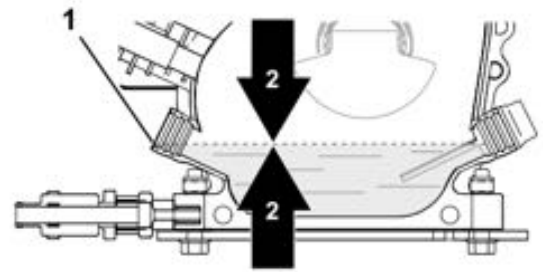

4. Install the oil-filter cap and wipe up any spilled oil.

# Changing the Engine Oil

**Service Interval:** After the first 20 hours and Ever 100 hours.

**Crankcase Capacity:** 0.63 US quarts

1. Start the engine and run it for a few minutes to warm the engine oil; then shut off the engine.
2. Remove the plug-in end of the hose and place the end of the hose into a drain pan with 1 US quart capacity.
3. Allow the oil to drain.
4. Install the plug-in end of the hose and wipe up any spilled oil.
5. Dispose of the waste oil properly.

**Note:** Recycle it according to local codes.

6. Fill the crankcase with the specified oil, refer to the *Engine Oil Specification* and *Checking the Engine-Oil Level* in the manual.

# Checking the Air-Filter Elements

**Service Interval:** Before each use or daily- check the air cleaner.

1. Remove the wing nut securing the air-cleaner cover to the air cleaner, and remove the cover.
2. Clean the air-cleaner cover thoroughly.

3. Check the foam air-filter element for dirt and debris. Clean the foam air-filter if needed.
4. Assemble the air-cleaner cover to the air cleaner with the wing nut.

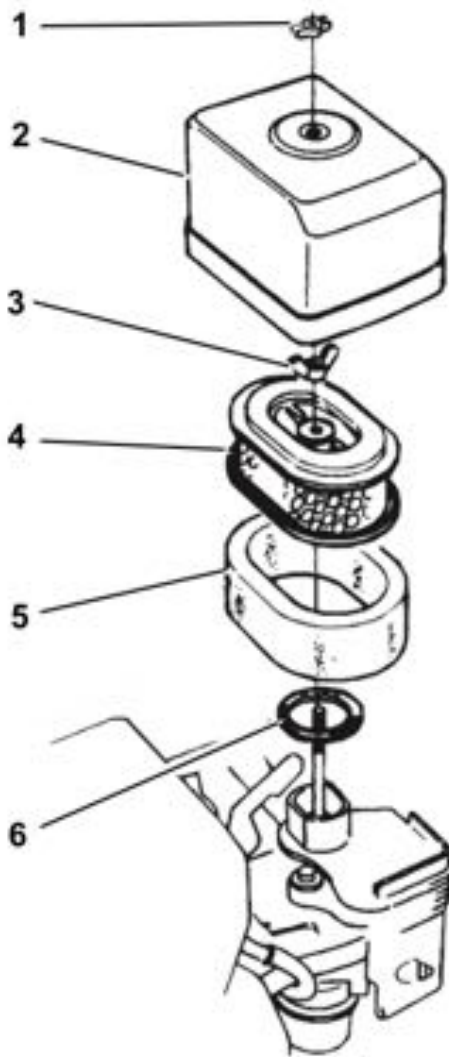

- |                      |                  |
|----------------------|------------------|
| 1. Wing nut          | 4. Paper element |
| 2. Air-cleaner cover | 5. Foam element  |
| 3. Wing nut          | 6. Gasket        |

## Servicing the Air Cleaner

**Service Interval:** Every 50 hours- clean the air cleaner (more often in dirty or dusty conditions).  
Every 300 hours- replace the paper element.

## Cleaning the Foam Air-Filter Element

1. Remove the wing nut securing the air-cleaner cover to the air cleaner, and remove the cover.
2. Remove the wing nut from the air filter, and remove the filter.
3. Remove the foam air-filter element from the paper element. If the paper air-filter element is dirty or damaged, clean it or replace it.
4. Wash the foam air-filter element in a solution of liquid soap and warm water.
5. Squeeze the foam element to remove the dirt.

**Important:** Do not twist the element, because the foam may tear.

6. Dry the foam element by wrapping it in a clean rag.
7. Squeeze the rag and foam element to dry the element.

**Important:** Do not twist the element, because the foam may tear.

8. Saturate the foam element with clean engine oil.
9. Squeeze the element to remove excess oil and to distribute the oil thoroughly.
10. **Note:** The foam element should be damp with oil.

## Cleaning the Paper Air-Filter Element

Clean the paper element by tapping the filter element several times on a hard surface to remove the dirt.

**Important:** Never brush dirt off the element or use compressed air to remove dirt; brushing forces dirt into the fibers, and compressed air will damage the paper filter.

## Assembling the Air Filter Elements

1. Assemble the foam air-filter element onto the paper element.
2. Inspect the gasket for wear and damage. Replace the gasket if it is worn or damaged.
3. Ensure that the gasket is positioned on the air inlet for the carburetor.
4. Assemble the air-filter elements to the carburetor with the wing nut.
5. Assemble the air-cleaner cover to carburetor with the other wing nut.

## Servicing the Spark Plug

**Service Interval:** Every 100 hours- check/adjust the spark plug.

Every 300 hours- replace the spark plug.

**Type:** NGK BPR6ES spark plug or equivalent.

**Air Gap:** 0.70 to 0.80 mm (0.028 to 0.031 inches)

1. Disconnect the spark-plug wire from the spark plug.

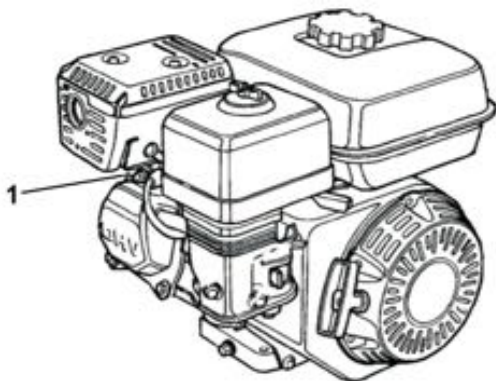

1. Spark-plug wire

2. Clean around the spark plug, and remove the plug from the cylinder head.

**Important:** Replace a cracked, fouled, or dirty spark plug. Do not sand blast, scrape,

or clean the electrodes, because engine damage could result from grit entering the cylinder.

3. Set the air gap to 0.70 to 0.80 mm (0.028 to 0.031 inch).

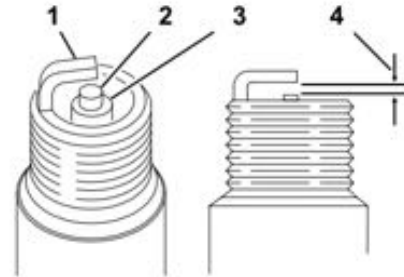

1. Side electrode  
2. Center electrode  
3. Insulator  
4. 0.70 to 0.80 mm (0.028 to 0.031 inch)

4. Install the correctly gapped spark plug carefully by hand to avoid cross-threading.
5. After the spark plug is seated, tighten it with a spark-plug wrench as follows:
  - a. When installing a new spark plug, tighten it 1/2 turn after the spark plug seats, to compress the gasket.
  - b. When installing the original spark plug, tighten it 1/8 to 1/4 turn after the spark plug seats, to compress the gasket.

**Important:** A loose spark plug can overheat and damage the engine. Overtightening the spark plug can damage the threads in the cylinder head.

6. Connect the spark-plug wire to the spark plug.

## Fuel System Maintenance

### Cleaning the Sediment Cup

**Service Interval:** Every 100 hours.

1. Move the fuel-shutoff valve to the *OFF* position.
2. Remove the fuel sediment cup and O-ring.
3. Check the O-ring for wear and damage; replace the O-ring if it is worn or damaged.
4. Wash the sediment cup and O-ring in nonflammable solvent, and dry them thoroughly.
5. Place the O-ring in the fuel shutoff valve and install the sediment cup. Tighten the sediment cup securely.

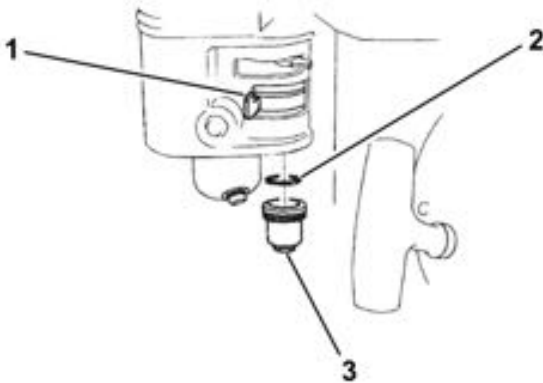

1. Fuel-shutoff valve      3. Sediment cup  
2. O-ring

## ***Electrical System Maintenance***

### **Electrical System Safety**

- Disconnect the battery before repairing the machine. Disconnect the negative terminal first and the positive last. Connect the positive terminal first and the negative last.
- Charge the battery in an open, well-ventilated area, away from sparks and flames. Unplug the charger before connecting or disconnecting the battery.
- Wear protective clothing and use insulated tools.

## **Replacing the Fuses**

The fuse block is located underneath the battery box cover.

There are 2 fuses:

- 40 amp- hose reel and acc power
- 10 amp- control board power

Common reasons for needing to replace fuses are:

- Battery voltage has dropped too low due to lack of charging. This causes higher amperage draw and could result in blown fuses. Charge the battery regularly to avoid.
- While rewinding the hose reel if the hose gets caught underneath an object it may cause a surge in draw, causing a blown fuse. Take care to avoid obstructing the hose when rewinding.

## **Charging the Battery**

**Service Interval:** After the first hour and after each use, before storage.

### **DANGER**

Contact with water while charging the machine could cause electric shock, causing injury or death.

- Do not handle the plug with wet hands or while standing in water.
- Do not charge the batteries in the rain or in wet conditions

### **WARNING**

A damaged charger cord can cause an electrical shock or fire.

**Thoroughly inspect the charger cord before charging the machine. If the cord is damaged, do not charge the machine until you obtain a replacement.**

To reduce the risk of electric shock, this charger has a 3-prong grounded plug (type B). If the plug does not fit into the wall receptacle, other grounded plug types are available; contact an Authorized Service Dealer.

Do not change the charger plug in any way.

**Important:** Check the charger cord periodically for holes or cracks in the insulation. Do not use a damaged cord. Do not run the cord through standing water or wet grass.

1. Park the machine in the designated location for charging.
2. Shut off the machine and remove the key.
3. Open the charger port and plug in an extension cord (not included) connected to a 120V GFCI electrical outlet.
4. On the onboard charger, use the *MODE* button to select the type of battery that is currently installed on the unit (confirm battery style on the unit by referencing the label on the battery).

**Note:** Once the battery type is selected, the charging process will begin.

5. When the battery is fully charged, the green light will illuminate.

**Note:** Battery charge indicator bars are located on the battery charger.

6. Disconnect the extension cord from the machine and close the charger port.

**Note:** The sprayer lights will flash five (5) times if the battery voltage is too low for certain functions to operate. Lights and strobes will not turn on below 11.9 battery voltage. If the lights and strobes are operating and the voltage drops below 11.9 the lights and strobes will automatically turn off. The engine starter will not function if the battery voltage is below 11.5 volts.

**Note:** The sprayer control computer system will shut down if the battery is below 9 volts.

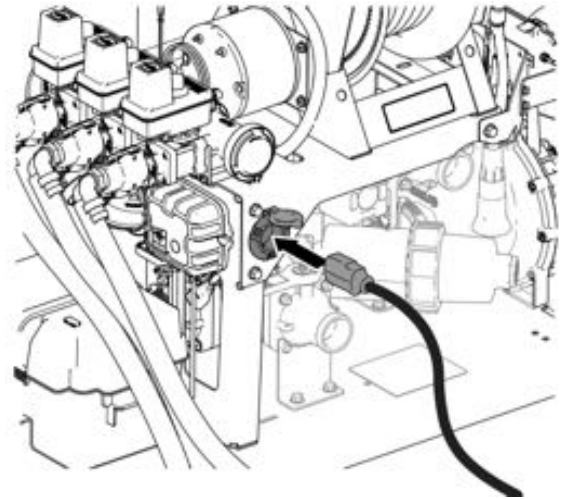

## Charging the Remote

The remote uses a USB C (supplied) connection to charge the battery. If the top left yellow LED is lit up this means the remote is charging. Once this LED is off the remote is fully charged. The charging plug is located on the top of the remote under the rubber cover. Plug the remote in and charge until the green light is displayed.

**Note:** The remote will automatically shut down after 15 minutes of inactivity to conserve battery life.

## Sprayer System Maintenance

### Inspecting the Tank Straps

**Service Interval:** After the first hour and before each use or daily.

The machine is equipped with stainless steel tank bands. It is important to frequently check the bands to ensure the straps are remaining tight. If a band can move freely by hand it should be tightened using the side and top adjustment bolts. Ensure to not over tighten as tank damage may occur.

## Inspecting the Hoses

**Service Interval:** Every 200 hours.

Examine each hose in the spray system for cracks, leaks, or other damage. At the same time, inspect the connections and fittings for similar damage. Replace any hoses and fittings if damaged.

## *Pump Maintenance*

### Inspecting the Pump

**Note:** The following machine components are considered parts subject to consumption through use unless found defective and are not covered by the warranty associated with this machine.

Have an authorized VSI dealer check the pump seals for damage and replace them if necessary.

## *Cleaning*

### Washing the Machine

**Service Interval:** Before each use or daily.

Wash the machine after each use using water alone or with a mild detergent. You may use a rag when washing the machine.

**Important:** Do not use brackish or reclaimed water to clean the machine.

**Note:** Do not use power-washing equipment to wash the machine. Power-washing equipment may damage the electrical system, loosen important decals, or wash away necessary grease at friction points. Avoid excessive use of water near the engine and onboard charger.

## Rinsing the Tank

**Service Interval:** Before storage.

After the season is complete, rinse out the sprayer tank and run fresh water through the entire system to wash out any salt residue.

## Draining the Pump

**Service Interval:** Before storage.

Remove the drain plug on the bottom of the pump to drain excess water from the pump.

## Conditioning the Sprayer System

**Service Interval:** Before storage.

After rinsing the tank, add RV antifreeze to the tank and run it through the entire system.

Open all valves to ensure no water is present inside the ball valve.

Remove the filter housing to drain water.

# Storage

## Storage Safety

Shut off the engine, remove the key (if equipped), wait for all movement to stop, and allow the machine to cool before adjusting, servicing, cleaning, or storing it.

## Prepare the Machine for Storage

1. Wash the machine.
2. Rinse the sprayer tank and sprayer components.
3. Drain the sprayer tank as completely as possible.
4. Condition the sprayer tank.
5. Grease and cap all connection points.
6. Drain the pump.
7. Charge the battery.
8. Disconnect power by pulling the fuse or disconnecting the grounding wire.

# Regulatory Statements

## FCC Statements

Per FCC 15.19(a)(3) and (a)(4): This device complies with part 15 of the FCC rules. Operation is subject to the following two conditions:

1. This device may not cause harmful interference, and
2. This device must accept any interference received, including interference that may cause undesired operation.

Cet appareil est conforme à la section 15 des réglementations de la FCC. Le fonctionnement de l'appareil est sujet aux deux conditions suivantes:

1. Cet appareil ne doit pas provoquer d'interférences néfastes, et
2. Cet appareil doit tolérer les interférences reçues, y compris celles qui risquent de provoquer un fonctionnement indésirable.

**Note:** This product has been tested and found to comply with the limits for a Class B digital device, pursuant to part 15 of the FCC Rules. These limits are designed to provide reasonable protection against harmful interference in a residential installation. This product generates, uses, and can radiate radio frequency energy and, if not installed and used in accordance with the instructions, may cause harmful interference to radio communications. However, there is no guarantee that interference will not occur in a particular installation. If this product does cause harmful interference to radio or television reception, which can be determined by turning the equipment off and on, the user is encouraged to try and correct the interference by one or more of the following measures:

- Reorient or relocate the receiving antenna.
- Increase the separation between the equipment and receiver.
- Connect the equipment into an outlet on a circuit different from that to which the receiver is connected.
- Consult the dealer or an experienced radio/TV technician for help.

**Warning:** Changes or modifications to this unit not expressly approved by the party responsible for compliance could void the user's authority to operate the equipment.



## **FCC Radiation Exposure Statement**

This equipment complies with FCC radiation exposure limits set forth for an uncontrolled environment. End users must follow the specific operation instructions for satisfying RF exposure compliance.

To satisfy RF exposure requirements, this device and its antenna must operate with a separation distance of at least 20 cm from all persons.

## **ISED Statements**

This device complies with Innovation, Science and Economic Development Canada's license-exempt RSS standard(s). Operation is subject to the following two conditions:

1. This device may not cause interference, and
2. This device must accept any interference, including interference that may cause undesired operation of the device.

Le présent appareil est conforme aux CNR d'Innovation, Sciences et Développement Économique Canada applicables aux appareils radioexempts de licence. L'exploitation est autorisée aux deux conditions suivantes:

1. L'appareil ne doit pas produire de brouillage, et
2. L'utilisateur de l'appareil doit accepter tout brouillage radioélectrique subi, même si le brouillage est susceptible d'en compromettre le fonctionnement.

Under Innovation, Science and Economic Development Canada's regulations, this radio transmitter may only operate using the external antenna under which it was approved.

Conformément à la réglementation d'Innovation, Sciences et Développement Économique Canada, le présent émetteur radio peut fonctionner avec une antenne fonctionnelle qu'en utilisant l'antenne intégrée sous laquelle il a été approuvé.

## **ISED RF Exposure Statement**

This equipment complies with ISED radiation exposure limits set forth for an uncontrolled environment. This equipment should be installed and operated with minimum distance 20cm between the radiator & your body. This transmitter must not be co-located or operating in conjunction with any other antenna or transmitter.

Le rayonnement de la classe b respecte ISED fixaient un environnement non contrôlés. Installation et mise en œuvre de ce matériel devrait avec échangeur distance minimale entre 20 cm ton corps. Lanceurs ou ne peuvent pas coexister cette antenne ou capteurs avec d'autres.

## **Transmit Antenna**

This radio transmitter 29449-LEGSPRA has been approved by Innovation, Science and Economic Development Canada to operate with the antenna types listed below, with the maximum permissible gain indicated. Antenna types not included in this list that have a gain greater than the maximum gain indicated for any type listed are strictly prohibited for use with this device.

Acceptable Antennas:

L-Com Model: HGV-2404U. 4 dBi Gain, 50 ohm impedance.

# **Voigt Smith Innovation LLC**

**150 East Sharon Street**

**Le Center, MN 56057**

**[www.vsinnovation.com](http://www.vsinnovation.com)**

**Main Office: 507-252-3033**

**Email: [sales@vsinnovation.com](mailto:sales@vsinnovation.com)**