



# EMC TEST REPORT

**Applicant** Alliedstar Medical Equipment Co., Ltd.  
**FCC ID** 2A8SG-AS200E  
**Product** Intraoral Scanner  
**Brand** AlliedStar  
**Model** AS 200E  
**Report No.** R2203A0251-E1V1  
**Issue Date** November 8, 2022

TA Technology (Shanghai) Co., Ltd. tested the above equipment in accordance with the requirements in **FCC Code CFR47 Part15B (2021)/ ANSI C63.4-2014**. The test results show that the equipment tested is capable of demonstrating compliance with the requirements as documented in this report.

*Liu Wei*

Prepared by: Liu Wei

*Fan Guangchang*

Approved by: Fan Guangchang

**TA Technology (Shanghai) Co., Ltd.**

Building 3, No.145, Jintang Rd, Tangzhen Industry Park, Pudong Shanghai, China

TEL: +86-021-50791141/2/3

FAX: +86-021-50791141/2/3-8000



## Table of Contents

1	Test Laboratory.....	5
1.1	Notes of the Test Report.....	5
1.2	Test facility.....	5
1.3	Testing Location.....	5
2	General Description of Equipment under Test.....	6
2.1	Applicant and Manufacturer Information.....	6
2.2	General information.....	6
2.3	Applied Standards.....	7
2.4	Test Mode.....	8
3	Test Case Results.....	9
3.1	Radiated Emission.....	9
3.2	Conducted Emission.....	14
4	Uncertainty Measurement.....	16
5	Main Test Instruments.....	17
	ANNEX A: The EUT Appearance.....	18
	ANNEX B: Test Setup Photos.....	19



Version	Revision description	Issue Date
Rev.0	Initial issue of report.	October 13, 2022
Rev.1	Update FCC ID.	November 8, 2022

Note: This revised report (Report No. R2203A0251-E1V1) supersedes and replaces the previously issued report (Report No. R2203A0251-E1). Please discard or destroy the previously issued report and dispose of it accordingly.



## Summary of measurement results

Number	Test Case	Clause in FCC Rules	Conclusion
1	Radiated Emission	FCC Part15.109, ANSI C63.4-2014	PASS
2	Conducted Emission	FCC Part15.107, ANSI C63.4-2014	NA
Date of Testing: July 23, 2022 ~ July 28, 2022			
Date of Sample Received: December 6, 2021			
Note: All indications of Pass/Fail in this report are opinions expressed by TA Technology (Shanghai) Co., Ltd. based on interpretations and/or observations of test results. Measurement Uncertainties were not taken into account and are published for informational purposes only.			

## 1 Test Laboratory

### 1.1 Notes of the Test Report

This report shall not be reproduced in full or partial, without the written approval of **TA technology (shanghai) co., Ltd.** The results documented in this report apply only to the tested sample, under the conditions and modes of operation as described herein. Measurement Uncertainties were not taken into account and are published for informational purposes only. This report is written to support regulatory compliance of the applicable standards stated above.

### 1.2 Test facility

#### **FCC (Designation number: CN1179, Test Firm Registration Number: 446626)**

TA Technology (Shanghai) Co., Ltd. has been listed on the US Federal Communications Commission list of test facilities recognized to perform measurements.

#### **A2LA (Certificate Number: 3857.01)**

TA Technology (Shanghai) Co., Ltd. has been listed by American Association for Laboratory Accreditation to perform measurement.

### 1.3 Testing Location

Company: TA Technology (Shanghai) Co., Ltd.  
Address: Building 3, No.145, Jintang Rd, Tangzhen Industry Park, Pudong Shanghai, China  
City: Shanghai  
Post code: 201201  
Country: P. R. China  
Contact: Fan Guangchang  
Telephone: +86-021-50791141/2/3  
Fax: +86-021-50791141/2/3-8000  
Website: <http://www.ta-shanghai.com>  
E-mail: [fanguangchang@ta-shanghai.com](mailto:fanguangchang@ta-shanghai.com)

## 2 General Description of Equipment under Test

### 2.1 Applicant and Manufacturer Information

<b>Applicant</b>	Alliedstar Medical Equipment Co., Ltd.
<b>Applicant address</b>	No.1-4, Floor 3, Unit 2, Building 3, No.222, West third section, Waihuan Road, Yanjiang District, Ziyang, 641300, Sichuan, P.R. China
<b>Manufacturer</b>	Alliedstar Medical Equipment Co., Ltd.
<b>Manufacturer address</b>	No.1-4, Floor 3, Unit 2, Building 3, No.222, West third section, Waihuan Road, Yanjiang District, Ziyang, 641300, Sichuan, P.R. China

### 2.2 General information

EUT Description			
Device Type	Portable Device		
Model	AS 200E		
Lab Internal SN	R2203A0251/S01		
HW Version	E		
SW Version	1.0.22.1		
Power Rating	DC 3.6V from battery		
Connecting I/O Port(s)	Please refer to the User's Manual.		
Antenna Type	Internal Antenna		
Frequency	Band	Tx (MHz)	Rx (MHz)
	Wi-Fi 5G(U-NII-1)	5150 ~ 5250	5150 ~ 5250
	Wi-Fi 5G(U-NII-3)	5725 ~ 5850	5725 ~ 5850
EUT Accessory			
Battery	Manufacturer: SHENZHEN RYDER ELECTRONICS CO., LTD. Model: Li-18650-3.6V 3500mAh-PCM-Cap DC 3.6V, 3500mAh		
Auxiliary test equipment			
PC	PC Manufacturer: Microsoft Corporation Model: L20170076		
<b>Note:</b> 1. The EUT is sent from the applicant to TA and the information of the EUT is declared by the applicant.			



## 2.3 Applied Standards

According to the specifications of the manufacturer, it must comply with the requirements of the following standards:

### Test standards

**FCC Code CFR47 Part15B (2021)**

**ANSI C63.4-2014**



## 2.4 Test Mode

Test Mode	
Mode 1	Battery powered for EUT+ Wireless module with PC power supply+ + WLAN Receiver



### 3 Test Case Results

#### 3.1 Radiated Emission

##### Ambient condition

Temperature	Relative humidity	Pressure
15°C~35°C	30%~60%	101.5kPa

##### Methods of Measurement

The EUT is placed on a non-metallic table 0.8m above the horizontal metal reference ground plane. The distance between EUT and receive antenna should be 3 meters. During the test, the EUT was operating in its typical mode. The test method is according to ANSI C63.4-2014. Sweep the whole frequency band through the range from 30MHz to the 5th harmonic of the carrier. During the test, the height of receive antenna shall be moved from 1 to 4 meters, and the antenna shall be performed under horizontal and vertical polarization. The turn table shall be rotated from 0 to 360 degrees for detecting the maximum of radiated signal level.

The data of cable loss and antenna factor has been calibrated in full testing frequency range before the testing. During the test, the EUT is worked at maximum output power.

Set the spectrum analyzer in the following:

Below 1GHz:

RBW=100 kHz / VBW=300 kHz / Sweep=AUTO

Above 1GHz:

(a) PEAK Detector: RBW=1MHz / VBW=3MHz / Sweep=AUTO

(b) AVERAGE Detector: RBW=1MHz / VBW=3MHz / Sweep=AUTO

The radiated emission was measured in the following position: EUT stand-up position (Z axis), lie-down position (X, Y axis). The worst emission was found in lie-down position (X axis) and the worst case was recorded.

**Test Setup**

**Below 1GHz**

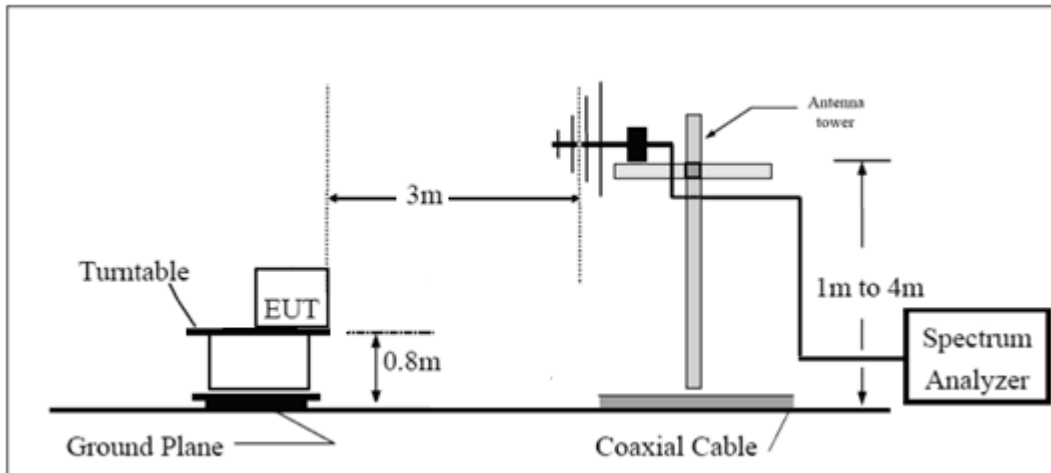

**Above 1GHz**

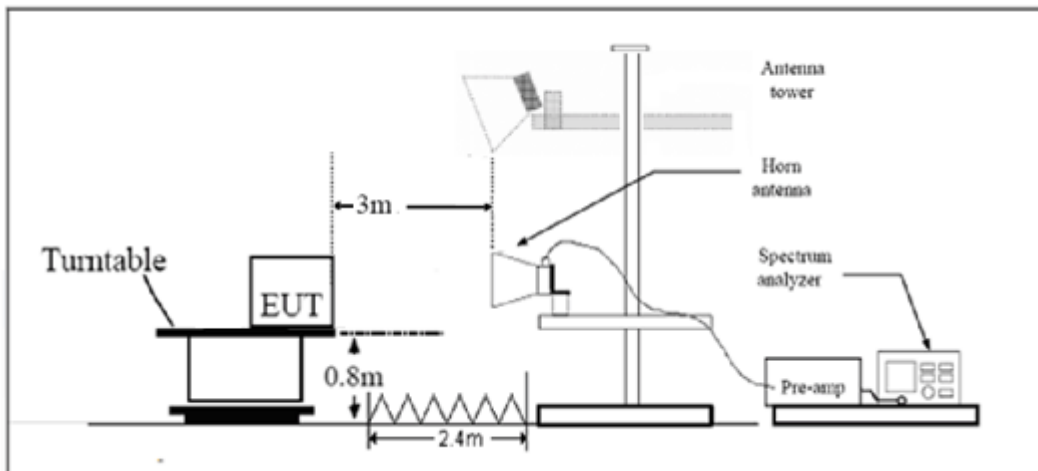

Note: Area side: 2.4mX3.6m

Antenna Tower meets ANSI C63.4 requirements for measurements above 1 GHz by keeping the antenna aimed at the EUT during the antenna's ascent/ descent along the antenna mast.

**Limits****Class B**

Frequency (MHz)	Field Strength (dB $\mu$ V/m)	Detector
30 -88	40.0	Quasi-peak
88-216	43.5	Quasi-peak
216 – 960	46.0	Quasi-peak
960-1000	54.0	Quasi-peak
1000-5 <sup>th</sup> harmonic of the highest frequency or 40GHz, which is lower	54 74	Average Peak

**Test Results**

Sweep the whole frequency band through the range from 30MHz to the 5th harmonic of the carrier. The Emissions in the frequency band 18GHz – 40GHz is more than 20dB below the limit are not reported.

The following graphs display the maximum values of horizontal and vertical by software. For above 1GHz, Blue trace uses the peak detection, Green trace uses the average detection.

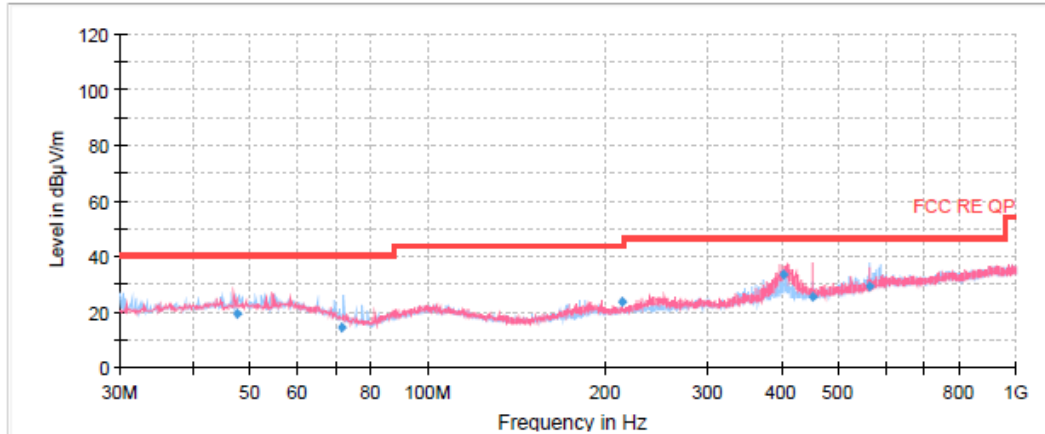

Radiated Emission from 30MHz to 1GHz

Frequency (MHz)	Quasi-Peak (dBuV/m)	Limit (dBuV/m)	Margin (dB)	Height (cm)	Polarization	Azimuth (deg)	Correct Factor (dB)
47.37	19.16	40.00	20.84	392.0	V	52.00	15
71.60	14.39	40.00	25.61	186.0	H	250.00	11
214.50	23.30	43.50	20.20	400.0	V	275.00	13
401.95	33.47	46.00	12.53	118.0	V	2.00	19
450.53	24.96	46.00	21.04	193.0	V	174.00	20
562.37	28.66	46.00	17.34	375.0	H	276.00	22

**Remark: 1. Correction Factor = Antenna factor + Insertion loss (cable loss+ amplifier gain)  
 2. Margin = Limit – Quasi-Peak**

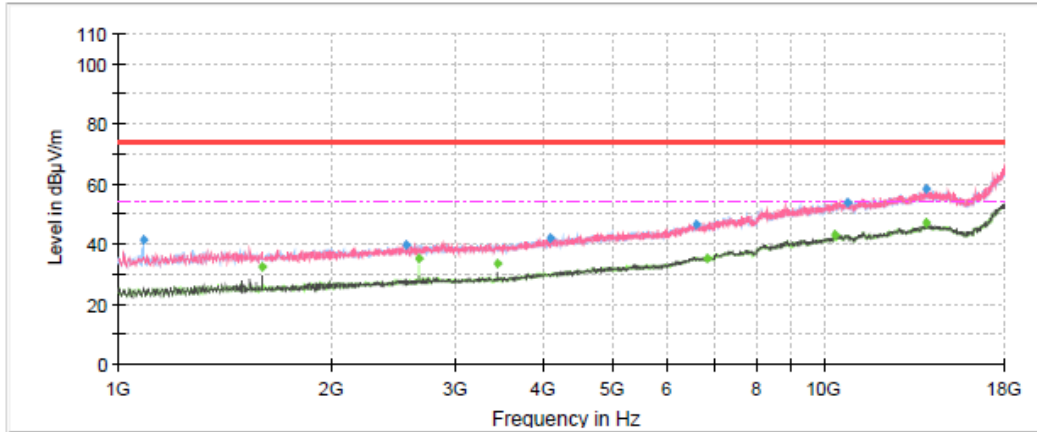

Radiated Emission from 1GHz to 18GHz

Frequency (MHz)	MaxPeak (dB µ V/m)	Average (dB µ V/m)	Limit (dB µ V/m)	Margin (dB)	Height (cm)	Pol	Azimuth (deg)	Corr. (dB/m)
1089.85	41.02	---	74.00	32.98	200.0	H	189.00	-19
1599.99	---	32.03	54.00	21.97	100.0	H	267.00	-16
2555.28	39.40	---	74.00	34.60	100.0	H	144.00	-14
2666.53	---	35.24	54.00	18.76	100.0	H	0.00	-14
3453.18	---	33.33	54.00	20.67	100.0	V	1.00	-13
4093.77	41.52	---	74.00	32.48	300.0	V	108.00	-10
6598.32	46.38	---	74.00	27.62	300.0	V	108.00	-2
6832.30	---	35.21	54.00	18.79	100.0	V	0.00	-1
10368.57	---	42.66	54.00	11.34	100.0	V	34.00	3
10792.49	53.87	---	74.00	20.13	400.0	V	358.00	4
13947.92	58.34	---	74.00	15.66	400.0	V	328.00	8
13953.87	---	46.71	54.00	7.29	400.0	V	336.00	8

Remark: 1. Correction Factor = Antenna factor + Insertion loss (cable loss + amplifier gain)

2. Peak Margin = Limit - MAX Peak/ Average

### 3.2 Conducted Emission

#### Ambient condition

Temperature	Relative humidity	Pressure
15°C~35°C	30%~60%	101.5kPa

#### Methods of Measurement

The EUT is placed on a non-metallic table of 80cm height above the horizontal metal reference ground plane. During the test, the EUT was operating in its typical mode. The test method is according to ANSI C63.4-2014. Connect the AC power line of the EUT to the L.I.S.N. Use EMI receiver to detect the average and Quasi-peak value. RBW is set to 9 kHz, VBW is set to 30kHz. The measurement result should include both L line and N line.

During the test, EUT is connected to a laptop via a USB cable in the case of Transfer Data mode. The EUT is used as the peripheral equipment of the PC. The data is transferred from EUT to PC; PC is connected to server via a long LAN cable.

#### Test Setup

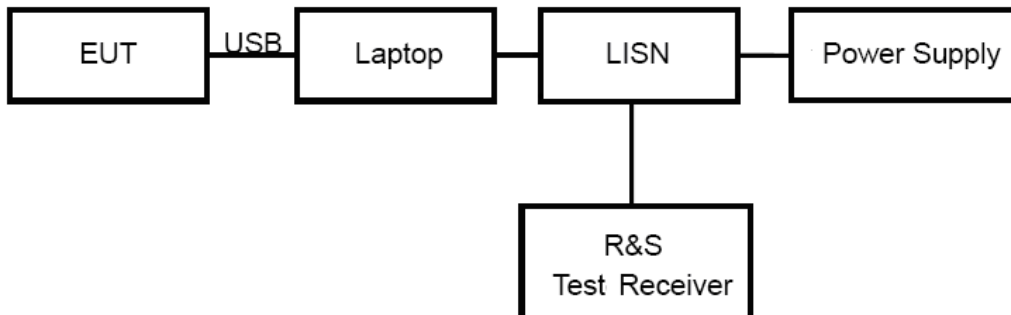

Note: Power Supply is AC Power source and it is used to change the voltage 120V/60Hz.

#### Limits

Frequency (MHz)	Conducted Limits(dBμV)	
	Quasi-peak	Average
0.15 - 0.5	66 to 56 *	56 to 46 *
0.5 - 5	56	46
5 - 30	60	50

\*: Decreases with the logarithm of the frequency.



## Test Results

The equipment doesn't connected to public network, therefore this requirement do not apply.

## 4 Uncertainty Measurement

Case	Uncertainty	Factor k
Radiated Emission 30MHz – 200MHz	4.17 dB	1.96
Radiated Emission 200MHz – 1GHz	4.84 dB	1.96
Radiated Emission 1GHz – 18GHz	4.35 dB	1.96
Radiated Emission 18GHz – 26.5GHz	5.90 dB	1.96
Radiated Emission 26.5GHz – 40GHz	5.92 dB	1.96



## 5 Main Test Instruments

Name of Equipment	Manufacturer	Type/Model	Serial Number	Calibration Date	Expiration Time
Radiated Emission					
Spectrum Analyzer	R&S	ESR	102389	2022-05-25	2023-05-24
Spectrum Analyzer	R&S	FSV40	100816	2021-12-12	2022-12-11
TRILOG Broadband Antenna	SCHWARZBECK	VULB 9163	1023	2020-05-05	2023-05-04
Horn Antenna	R&S	HF907	102723	2020-08-11	2023-08-10
Horn Antenna	ETS-Lindgren	3160-09	00102643	2021-10-10	2024-10-09
Horn Antenna	STEATITE	QSH-SL-26-40-K-15	16779	2019-12-24	2022-12-23
Software	R&S	EMC32	9.26.01	/	/

\*\*\*\*\*END OF REPORT \*\*\*\*\*



## **ANNEX A: The EUT Appearance**

The EUT Appearance are submitted separately.



## **ANNEX B: Test Setup Photos**

The Test Setup Photos are submitted separately.