

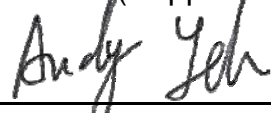

# TEST REPORT

**Applicant** : SHANGHAI MOUNTAIN VIEW SILICON CO., LTD  
**PRODUCT NAME** : MV\_BP10xx PCB Antenna  
**MODEL NAME** : MV\_BP10  
**TRADE NAME** : MVSILICON  
**BRAND NAME** : MVSILICON  
**STANDARD(S)** : ANSI/IEEE Std 149-2008  
**RECEIPT DATE** : 2019-08-30  
**TEST DATE** : 2019-09-02  
**ISSUE DATE** : 2019-10-15

Edited by:   
Chi Shide(Rapporteur)

Approved by:   
Andy Yeh(Technical Director)

**NOTE:** This document is issued by MORLAB, the test report shall not be reproduced except in full without prior written permission of the company. The test results apply only to the particular sample(s) tested and to the specific tests carried out which is available on request for validation and information confirmed at our website.





# DIRECTORY

- 1. Technical Information..... 3
  - 1.1. Manufacturer and Factory Information ..... 3
  - 1.2. Equipment Under Test (EUT) Description ..... 3
- 2. Test Results ..... 4
  - 2.1. Applied Reference Documents ..... 4
  - 2.2. Test Conditions ..... 4
  - 2.3. Test Results lists..... 4
- Annex A Photographs ..... 6
- Annex B Figures ..... 7
  - 1. 2D Radiation Pattern ..... 7
  - 2. 3D Radiation Pattern ..... 9
  - 3. Return Loss ..... 10
  - 4. VSWR..... 11
  - 5. Input Impedance ..... 11
- Annex C Photographs ..... 12
- Annex D General Information ..... 14
  - 1.1 Identification of the Responsible Testing Laboratory ..... 14
  - 1.2 Identification of the Responsible Testing Location ..... 14
  - 1.3 Test Equipments Utilized ..... 14

Change History		
Version	Date	Reason for change
1.0	2019-10-15	First edition



# 1. Technical Information

**Note:** Provide by manufacturer.

## 1.1. Manufacturer and Factory Information

<b>Applicant:</b>	SHANGHAI MOUNTAIN VIEW SILICON CO., LTD
<b>Applicant Address:</b>	Suite 4C, Building 3, 1238 Zhangjiang Road, Pudong New District, Shanghai, China
<b>Manufacturer:</b>	SHANGHAI MOUNTAIN VIEW SILICON CO., LTD
<b>Manufacturer Address:</b>	Suite 4C, Building 3, 1238 Zhangjiang Road, Pudong New District, Shanghai, China

## 1.2. Equipment Under Test (EUT) Description

Wireless Type	N/A
Frequency	N/A



## 2. Test Results

### 2.1. Applied Reference Documents

Leading reference documents for testing:

No.	Identity	Document Title
1	ANSI/IEEE Std 149-2008	IEEE Standard Test Procedures for Antennas

### 2.2. Test Conditions

Test Environment Conditions:

Relative Humidity:	25 ... 75 %
Temperature:	+10 °C to +30 °C

### 2.3. Test Results lists

#### 2.3.1. Gain

Frequency	Gain(dBi)
2400MHz	2.81
2410MHz	2.74
2420MHz	3.38
2430MHz	2.73
2440MHz	1.01
2450MHz	1.26
2460MHz	1.50
2470MHz	1.49
2480MHz	1.42
2490MHz	0.36
2500MHz	0.33



### 2.3.2.Return Loss/VSWR/Input Impedance

Frequency	Return Loss (dB)	VSWR	Input Impedance( $\Omega$ )
2400MHz	-7.23	2.53	25.37
2440MHz	-6.47	2.80	17.99
2450MHz	-6.22	2.90	17.18
2480MHz	-5.18	3.44	15.55
2500MHz	-4.56	3.89	15.48

## Annex A Photographs

### 1. Test Setup

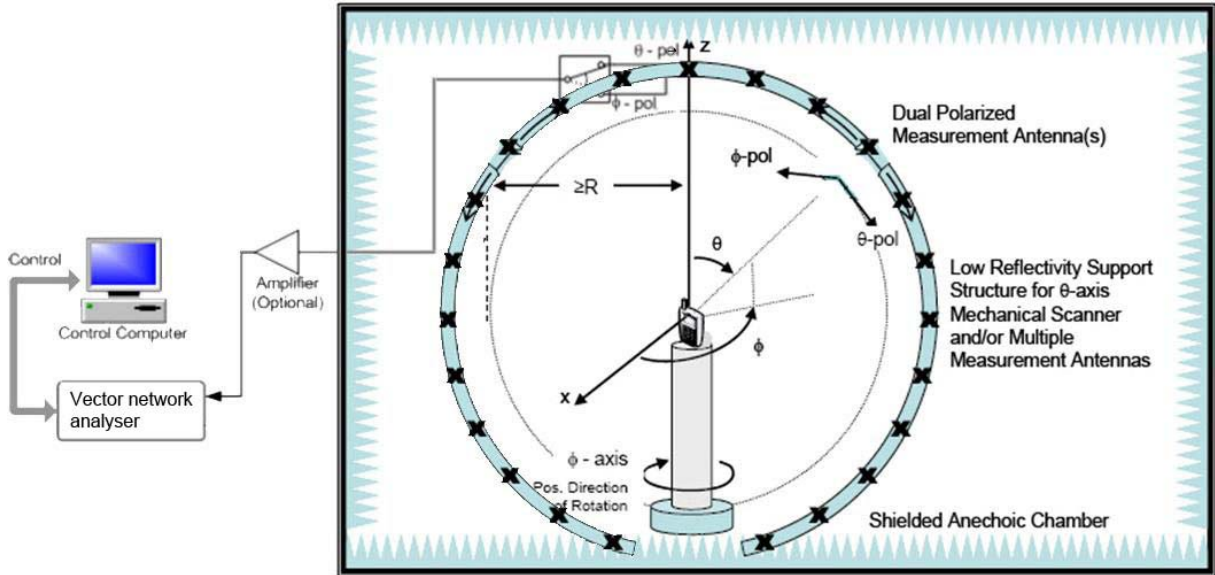

## Annex B Figures

### 1. 2D Radiation Pattern

Phi=0°

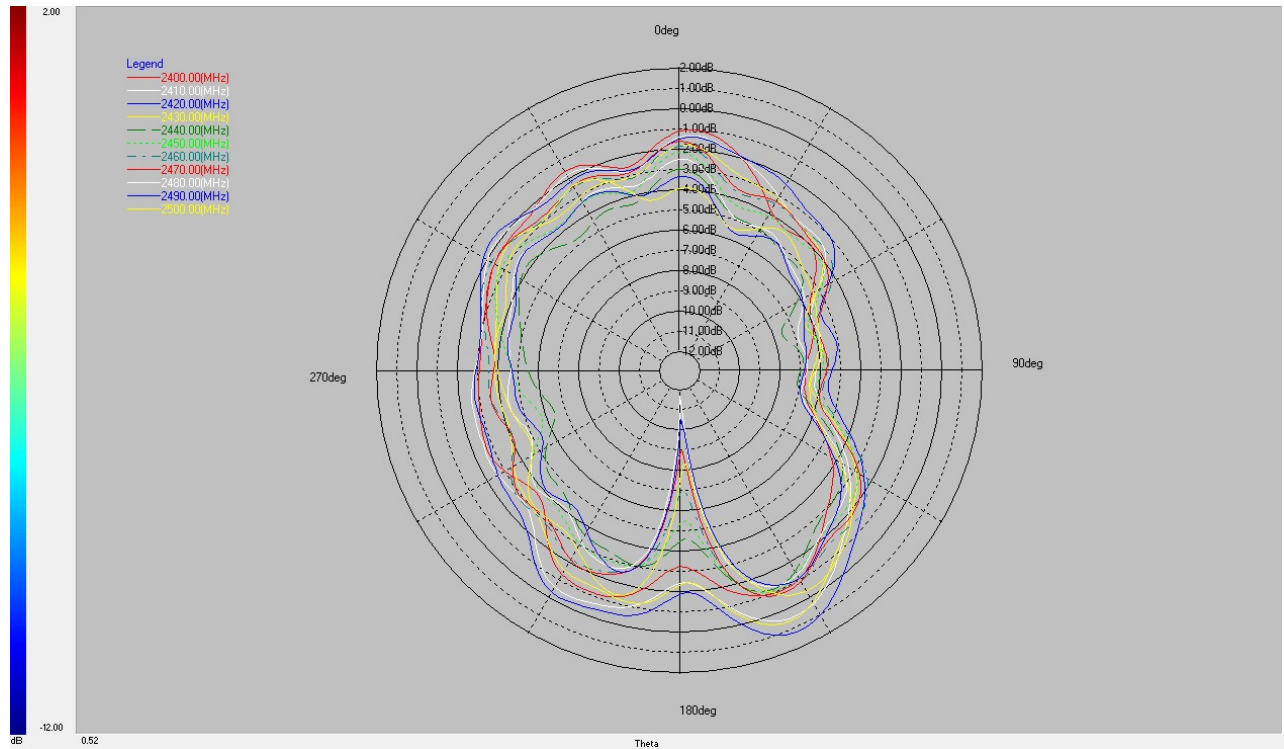



Phi=90°

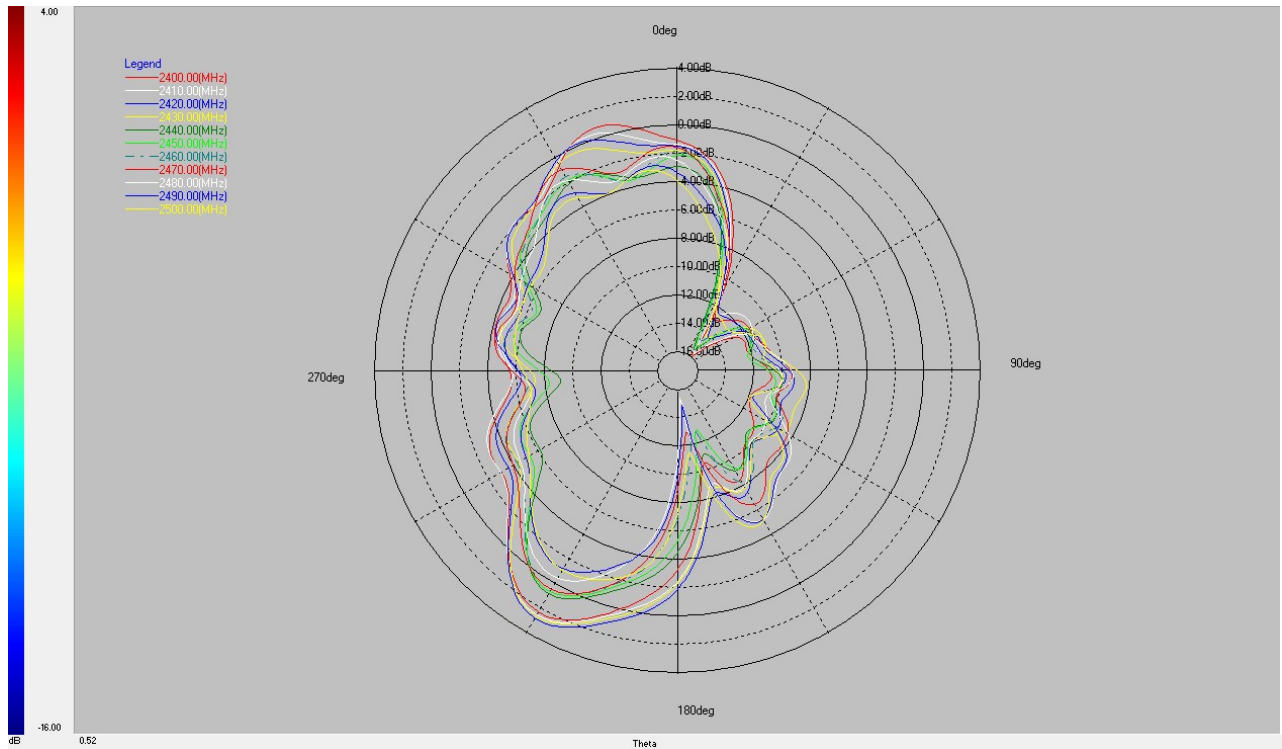

Theta=90°

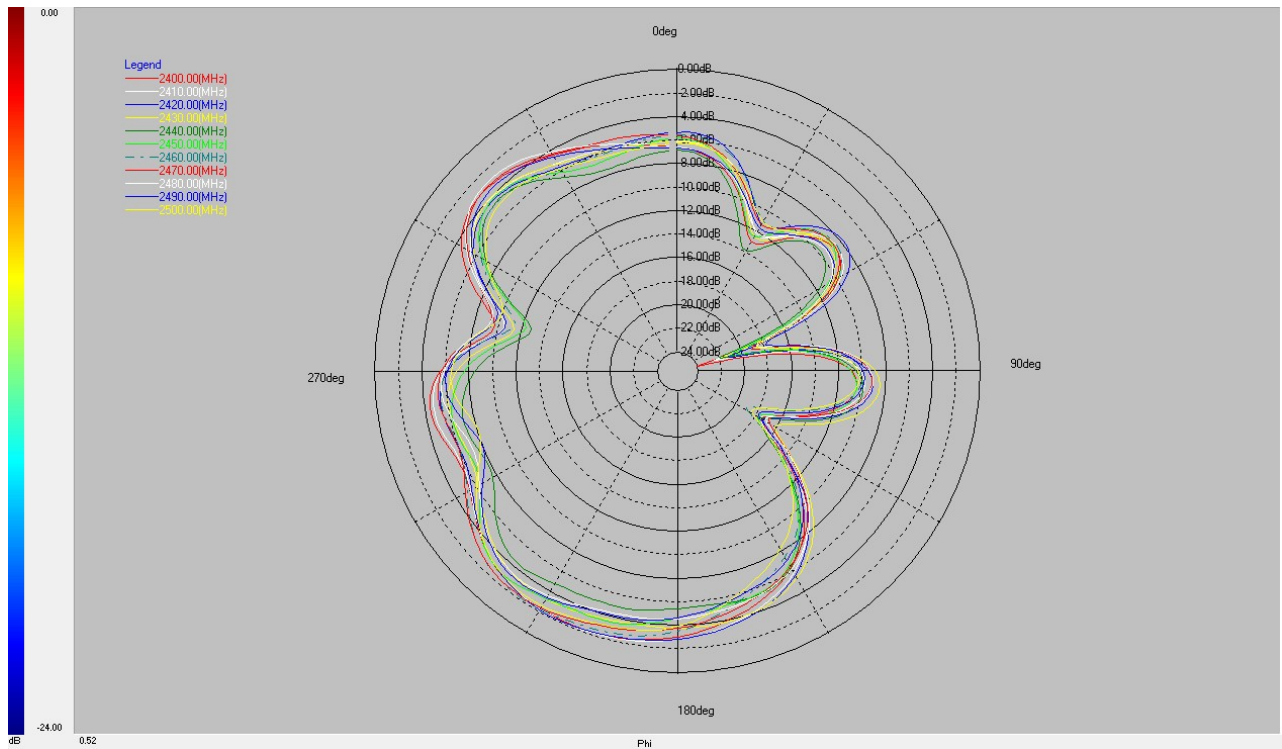



## 2. 3D Radiation Pattern

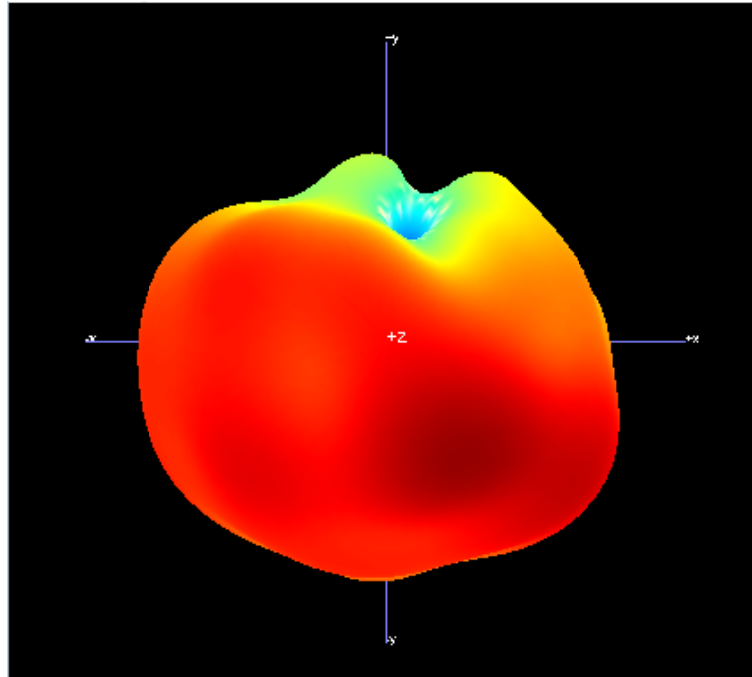

2400MHz

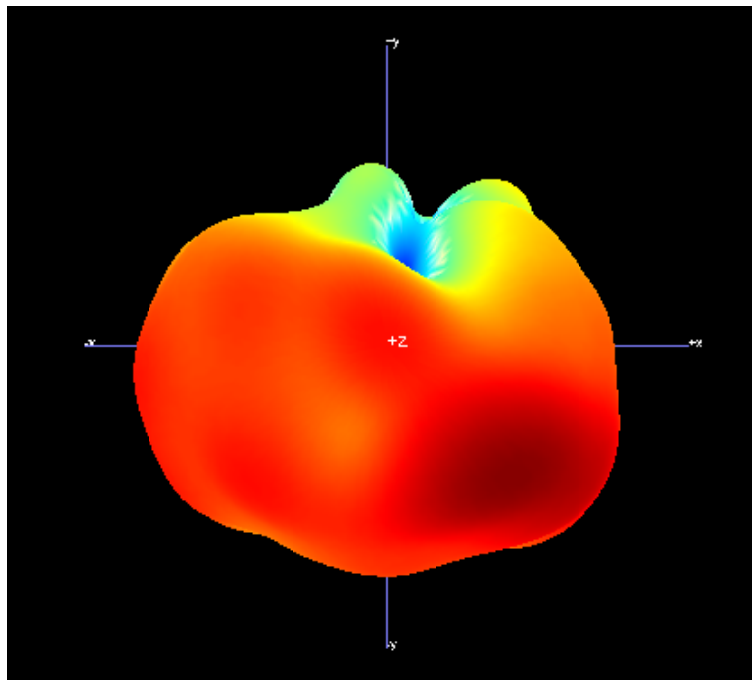

2450MHz

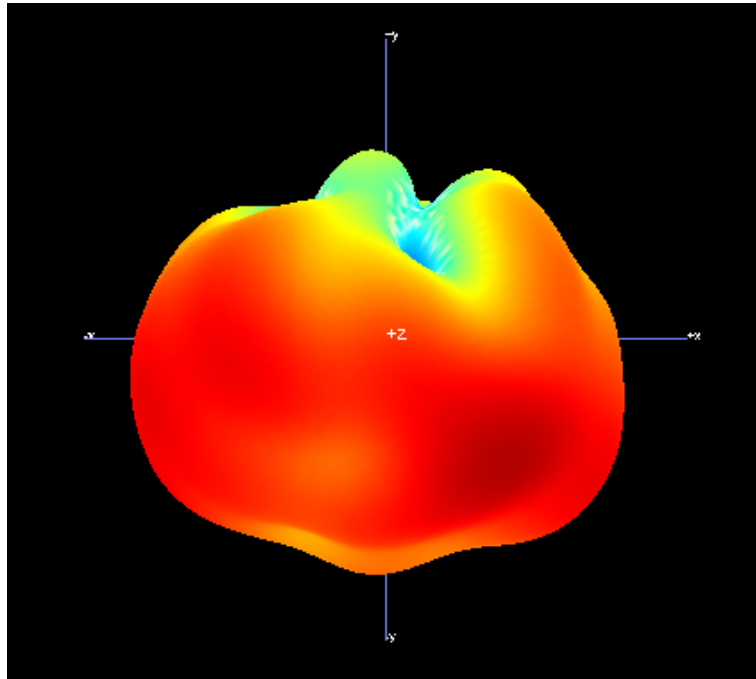

2500MHz

### 3. Return Loss

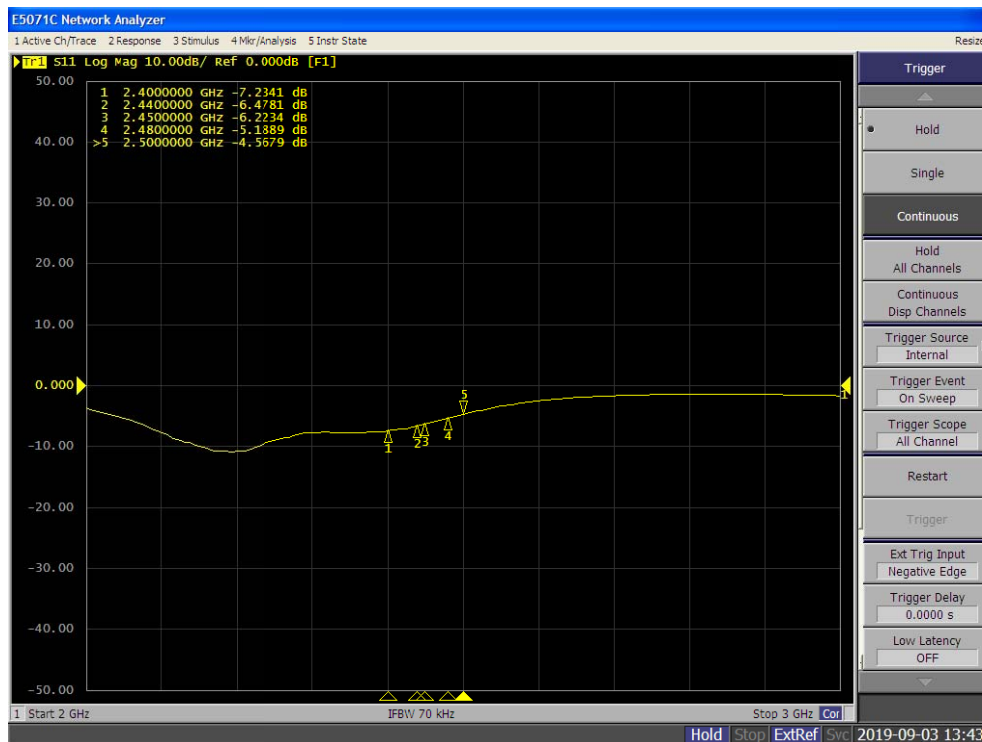



### 4. VSWR

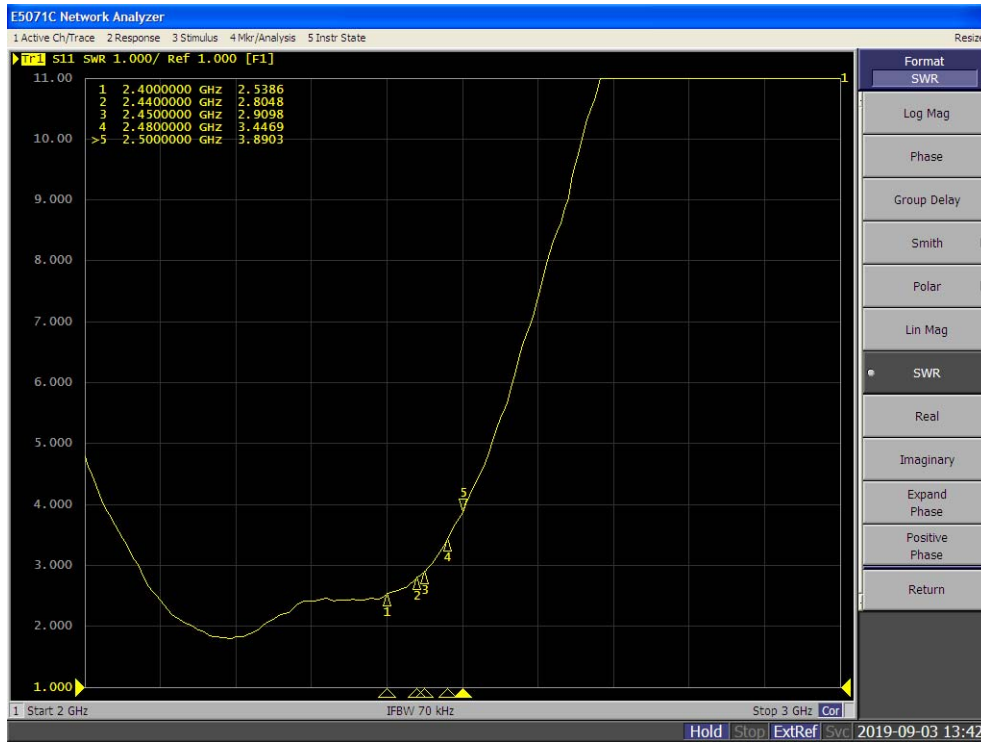

### 5. Input Impedance

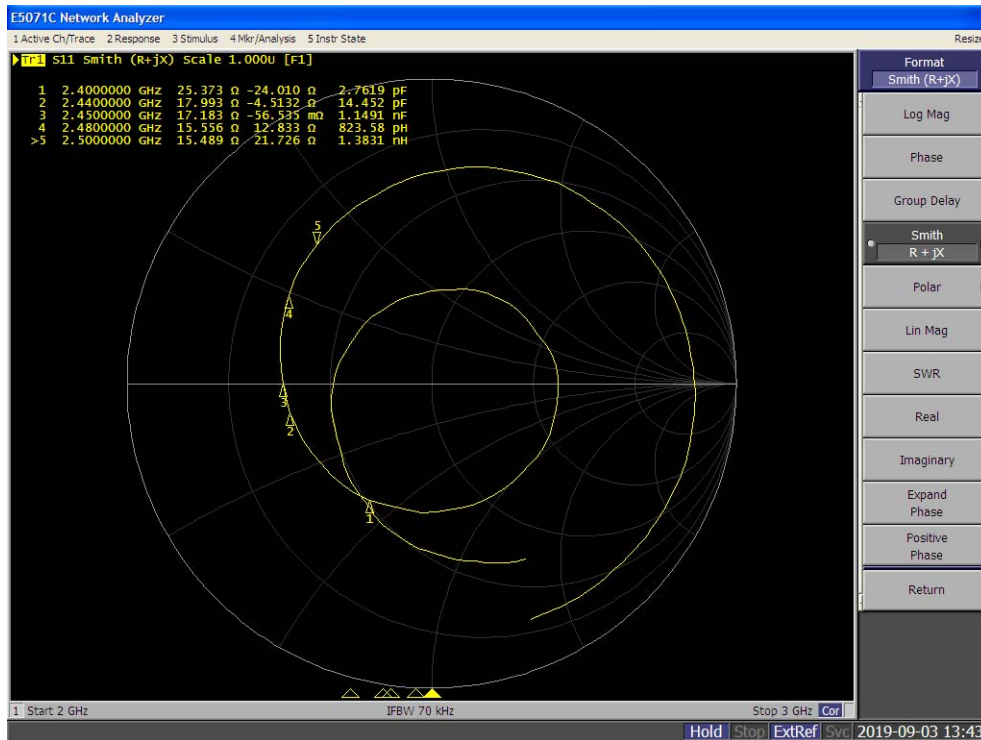

## Annex C Photographs

### 1. Test environment

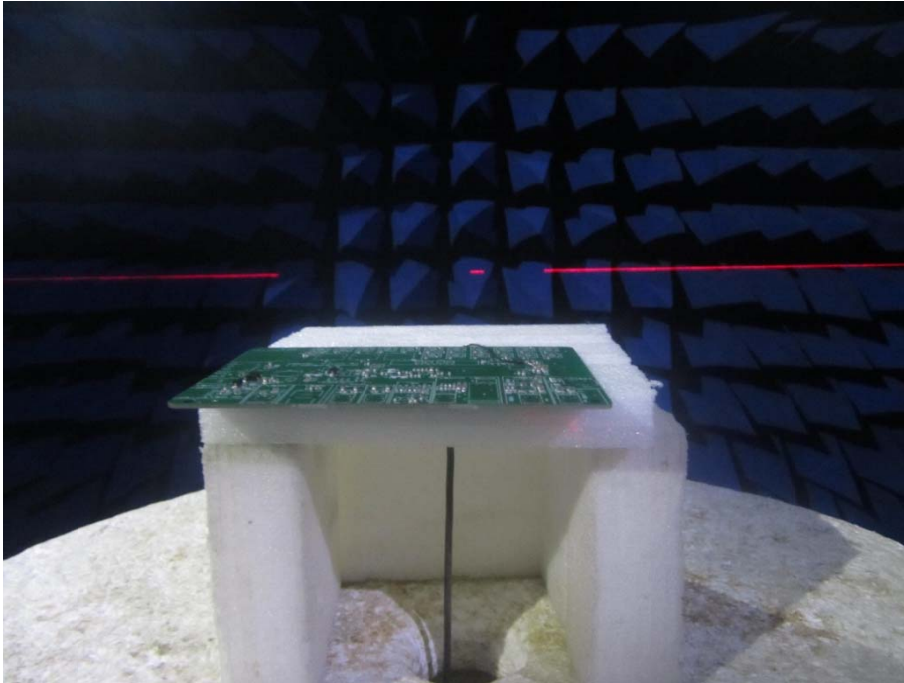

### 2. EUT

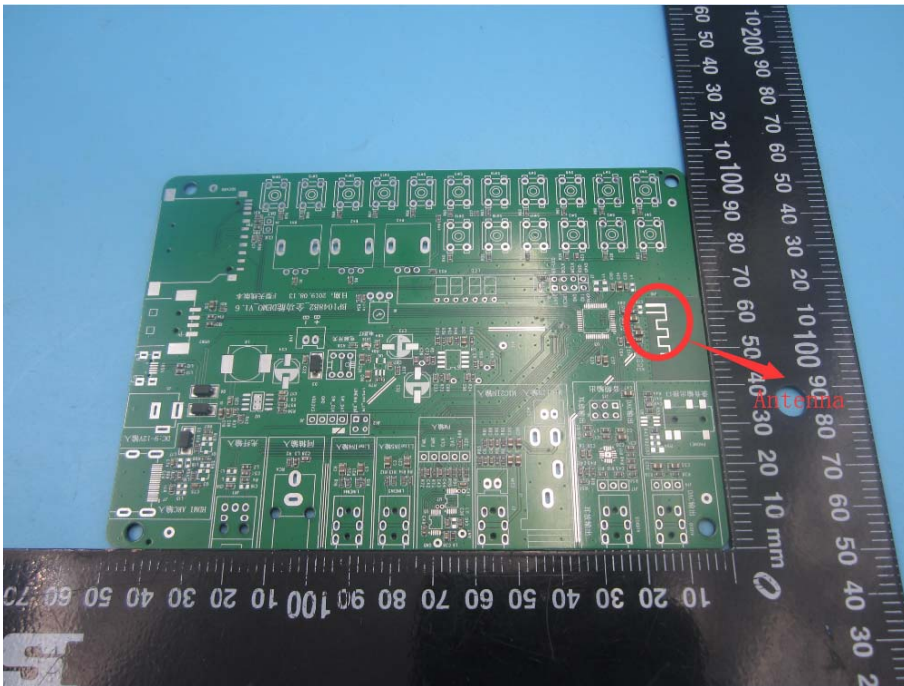

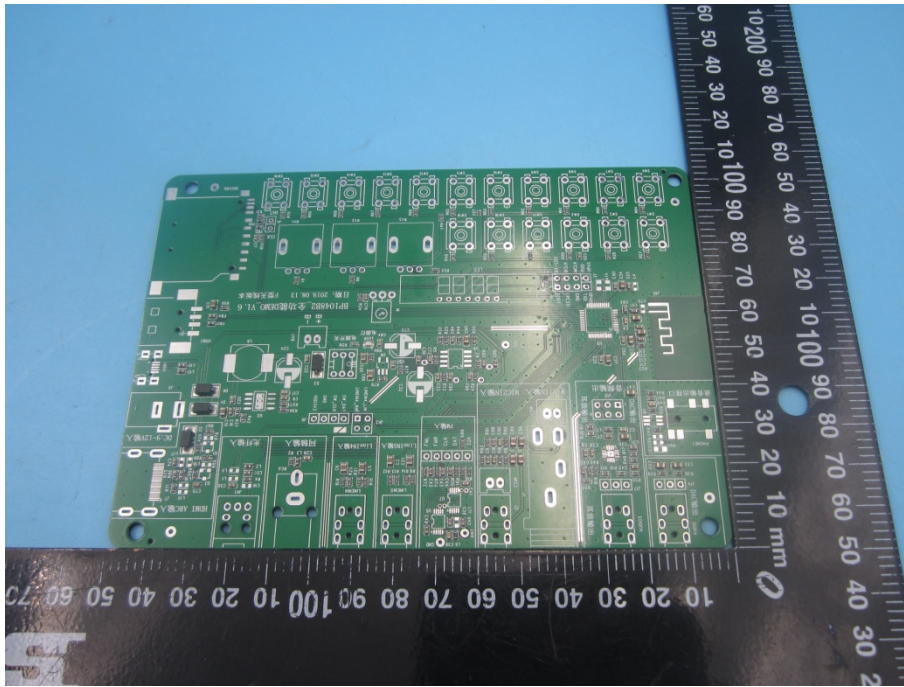



## Annex D General Information

### 1.1 Identification of the Responsible Testing Laboratory

Laboratory Name:	Shenzhen Morlab Communications Technology Co., Ltd. Morlab Laboratory
Laboratory Address:	FL1-3, Building A, FeiYang Science Park, No.8 LongChang Road, Block67, BaoAn District, ShenZhen , GuangDong Province, P. R. China
Telephone:	+86 755 36698555
Facsimile:	+86 755 36698525

### 1.2 Identification of the Responsible Testing Location

Name:	Shenzhen Morlab Communications Technology Co., Ltd. Morlab Laboratory
Address:	FL1-3, Building A, FeiYang Science Park, No.8 LongChang Road, Block67, BaoAn District, ShenZhen , GuangDong Province, P. R. China

### 1.3 Test Equipments Utilized

#### 1.3.1 List of Test Equipment

No.	Type	Specification
1	E5071C Vector Network Analyzer	Manufacturer: Agilent
2	4*4*4 Full Anechoic Chamber	Manufacturer: Satimo
3	SG24 Multi-probe Antenna Measurement System	Manufacturer: Satimo

————— END OF REPORT —————



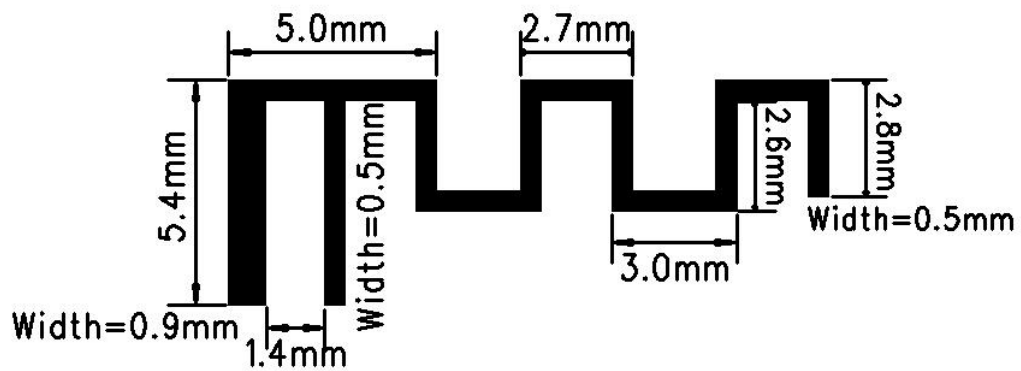

Actual Size

Notes:

- 1, The pin of the Bluetooth antenna with a wire diameter of 0.9mm should be connected to GND.
- 2, The wire diameter of the Bluetooth antenna is 0.5mm, as shown in the diagram below.
- 3, The copper gap between Bluetooth antenna lines is 2.3mm, as shown in the diagram.

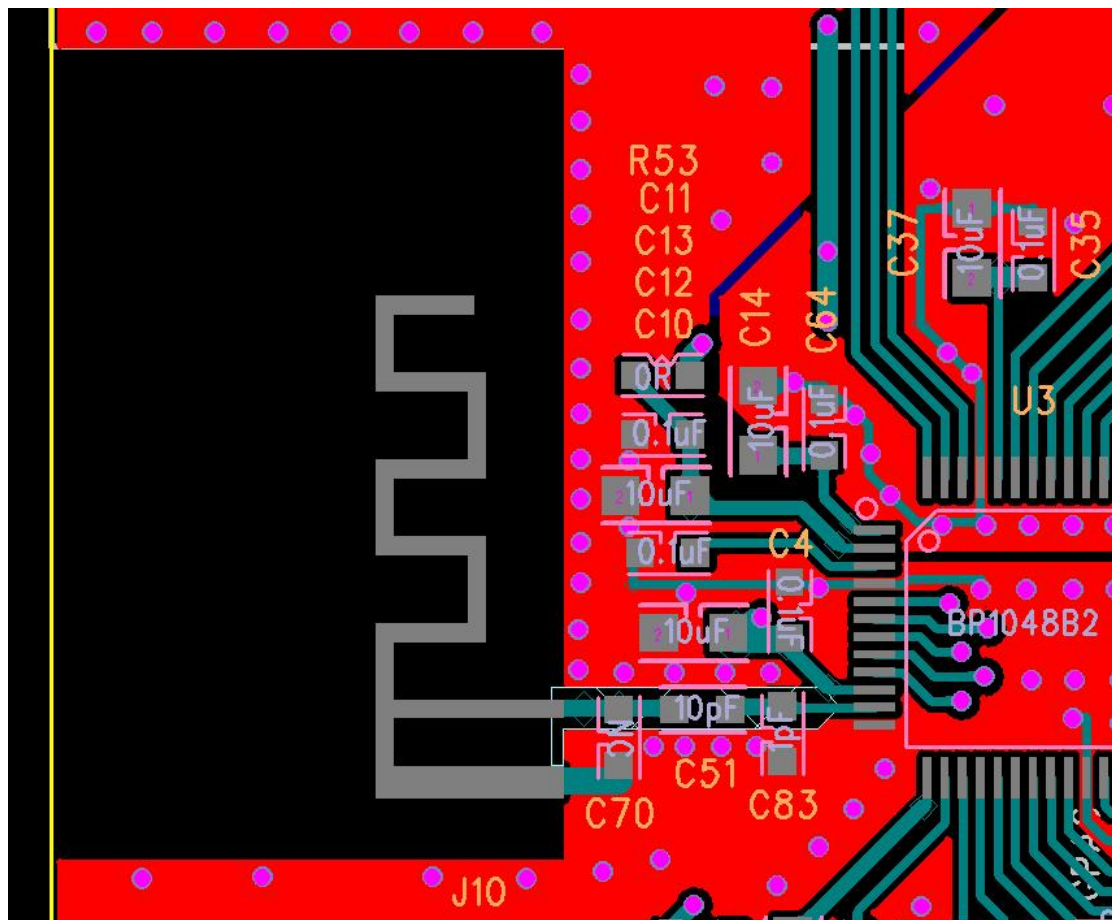

4. The attachment is a reference circuit network for antenna matching. It is recommended to place the matching components as close as possible to the chip pins.

