

| ITEM NO. | PART NUMBER | DESCRIPTION | QTY. |
|----------|------------------|---|------|
| 1 | DESIGN-ASM-00100 | PCB ASSEMBLY, TEMP SHIELD MODULE | 1 |
| 2 | DESIGN-COM-00029 | BATTERY, TEMP SHIELD MODULE | 1 |
| 3 | DESIGN-COM-00003 | FRAME, TEMP SHIELD MODULE | 1 |
| 4 | DESIGN-COM-00002 | IDION DECAL, TEMP SHIELD MODULE | 1 |
| 5 | DESIGN-ASM-00001 | INNER SEAL ASSEMBLY, TEMP SHIELD MODULE | 1 |
| 6 | DESIGN-ASM-00002 | FOAM FILLER, TEMP SHIELD MODULE | 1 |
| 7 | DESIGN-COM-00005 | PCB PSA, TEMP SHIELD MODULE | 1 |
| 8 | DESIGN-COM-00028 | THERMAL PASTE, 20MG PER ASSEMBLY | 1 |
| 10 | DESIGN-COM-00006 | TEMP SENSOR HEAT PIPE | 1 |
| 11 | DESIGN-COM-00064 | 3M EPOXY DP100 | 1 |

| REV. | DESCRIPTION | DATE | APPROVED |
|------|------------------------------|-----------|----------|
| 01 | INITIAL RELEASE | 5/26/2022 | DPG |
| 02 | ADD ITEM 10 | 7/18/2022 | DPG |
| 03 | ADDED SHEET 3 AND EPOXY STEP | 12/7/2022 | DPG |

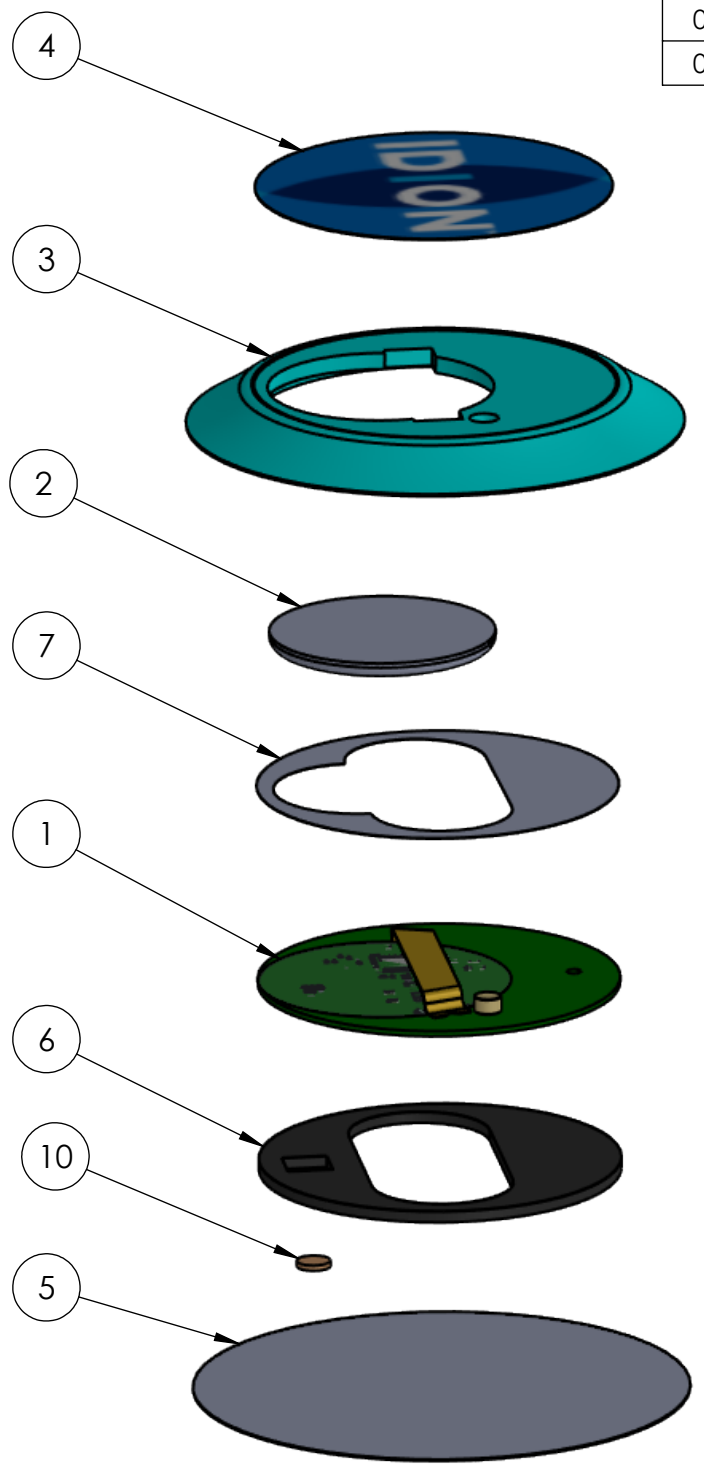

WORK INSTRUCTIONS TO BE MADE BY MANUFACTURER - CRITICAL STEPS TO BE LISTED ON THIS DRAWING

| | | | | |
|--|--|--|-----------------------------|--|
| | UNLESS OTHERWISE SPECIFIED: DIMENSIONS ARE IN MM TOLERANCES ARE: .X ± .75 .XX ± .5 .XXX ± .25 X° ± 1° ALL SURFACES | DRAWN BY HGRAY CHECKED BY DPG THIRD ANGLE PROJECTION | DATE 5/26/2022 | DESCRIPTION ASSEMBLY, TEMP SHIELD MODULE |
| | THIS DRAWING, IN TOTAL OR IN PART, IS PRIVATE AND CONFIDENTIAL AND IS SUPPLIED ONLY ON THE EXPRESS CONDITION THAT IT IS NOT TO BE USED BY, COPIED BY, OR COMMUNICATED TO, ANY OTHER PERSON WITHOUT WRITTEN AUTHORIZATION FROM SUNRISE LABS, INC. 25 CONSTITUTION DRIVE, BEDFORD, NH 03110 | SIZE B | PROJECT CODE IDND | PART NUMBER DESIGN-ASM-00009-02 |

ENSURE THAT DESIGN-COM-00005 IS ORIENTED SUCH THAT THE ADHESIVE CLEARS THE BATTERY STRAP AND THE CYLINDER ON THE PCB

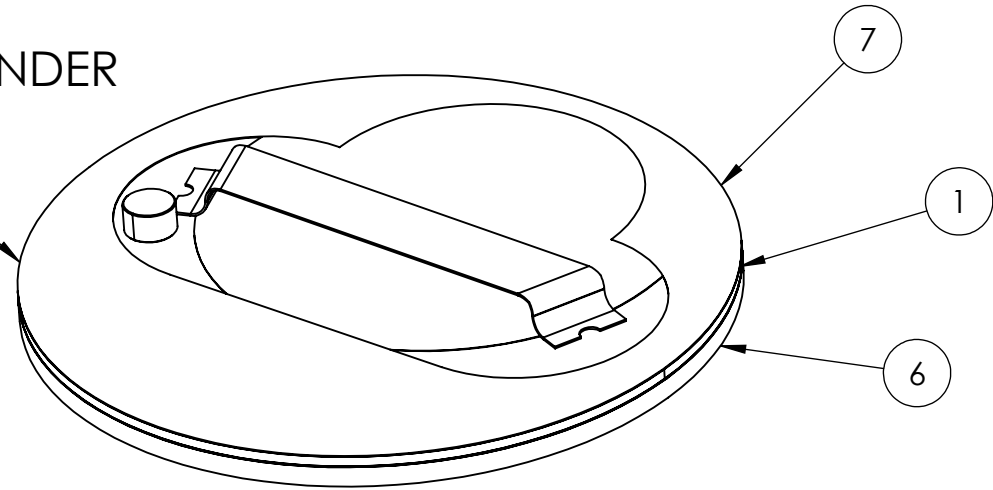

SLIDE BATTERY (DESIGN-COM-00029) UNDER BATTERY STRAP (DESIGN-COM-00001) AFTER ADHESIVE (DESIGN-COM-00005) HAS BEEN APPLIED AND RELEASE LINER REMOVED

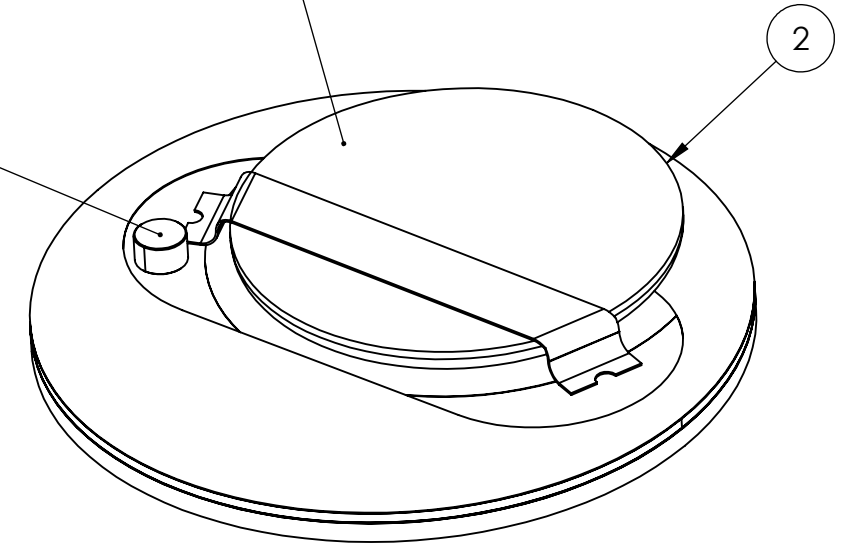

APPLY THERMAL PASTE (DESIGN-COM-00029) TO EXPOSED TEMPERATURE SENSOR AFTER INSERTION INTO SILICONE FRAME (DESIGN-COM-00003) AND FILL CAVITY.

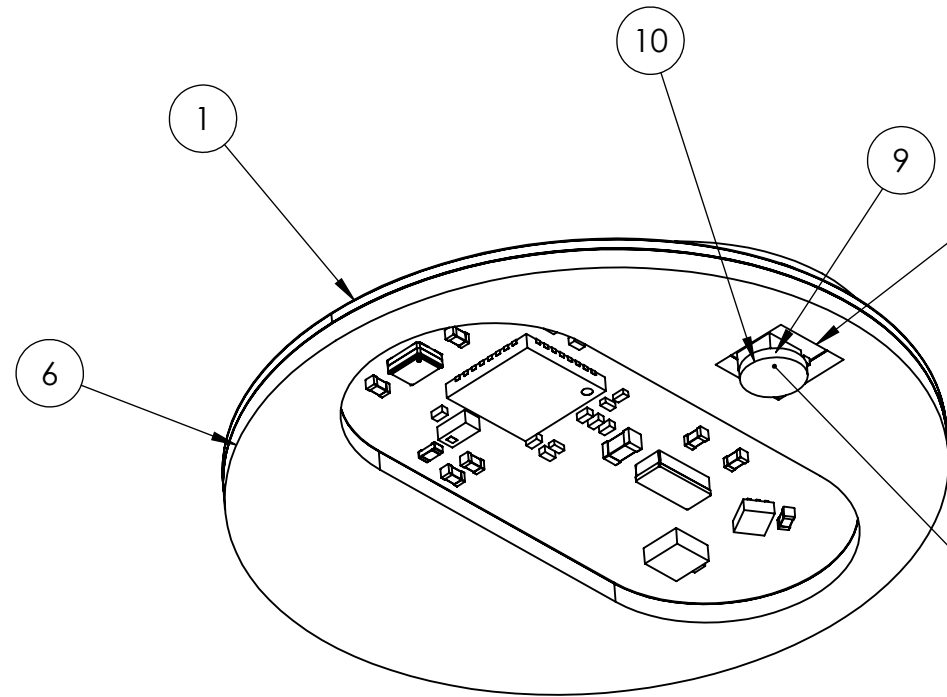

ENSURE THAT DESIGN-ASM-00002 IS ORIENTED SUCH THAT THE TEMPERATURE SENSOR ON PCB IS EXPOSED THROUGH THE SQUARE HOLE

APPLY THERMAL PASTE (DESIGN-COM-00028) TO EXPOSED TEMPERATURE SENSOR. FILL FOAM CAVITY AROUND HEAT PIPE (DESIGN-COM-00006).

| | | | |
|---|------------------------------|--------------|--|
|  | DESCRIPTION | | |
| | Assembly, Temp Shield Module | | |
| CLIENT CODE | PART NUMBER | REV | |
| IDND | DESIGN-ASM-00009 | 03 | |
| SIZE B | SCALE 3:1 | SHEET 2 of 4 | |

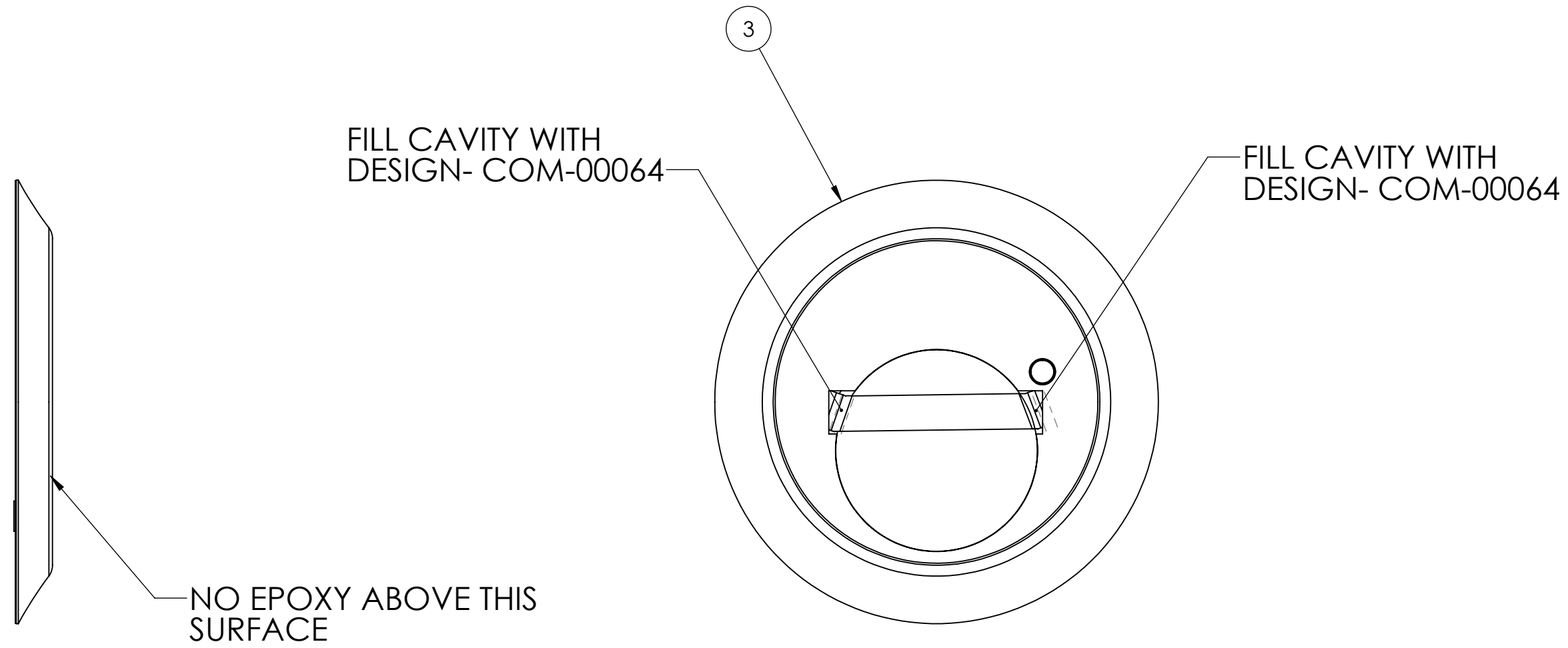



FILL CAVITY WITH
DESIGN- COM-00064

FILL CAVITY WITH
DESIGN- COM-00064

NO EPOXY ABOVE THIS
SURFACE

3

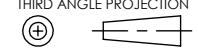
| | | | | | |
|--|---|-------------------|-------------------|--|------------------------------------|
|   | UNLESS OTHERWISE SPECIFIED: DIMENSIONS ARE IN MM | DRAWN BY HGRAY | DATE | DESCRIPTION ASSEMBLY, TEMP SHIELD MODULE | |
| | TOLERANCES ARE: .X ± .75 .XX ± .5 .XXX ± .25 X° ± 1° ALL SURFACES | CHECKED BY DPG | DATE 5/26/2022 | PROJECT CODE IDND | PART NUMBER DESIGN-ASM-00009-02 |
| <small>THIS DRAWING, IN TOTAL OR IN PART, IS PRIVATE AND CONFIDENTIAL AND IS SUPPLIED ONLY ON THE EXPRESS CONDITION THAT IT IS NOT TO BE USED BY, COPIED BY, OR COMMUNICATED TO, ANY OTHER PERSON WITHOUT WRITTEN AUTHORIZATION FROM SUNRISE LABS, INC. 25 CONSTITUTION DRIVE, BEDFORD, NH 03110</small> | THIRD ANGLE PROJECTION  | SIZE B | SCALE 2:1 | SHEET 3 of 4 | |

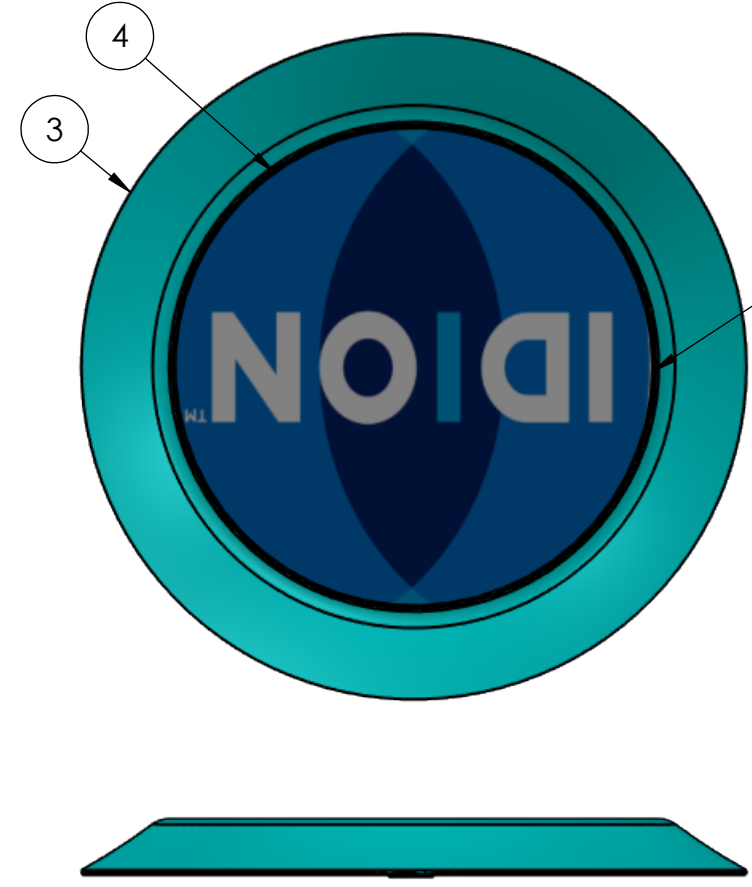

ENSURE THAT OUTER PERIMETER OF DESIGN-COM-00002 FALLS WITHIN RECESS OF DESIGN-COM-00003

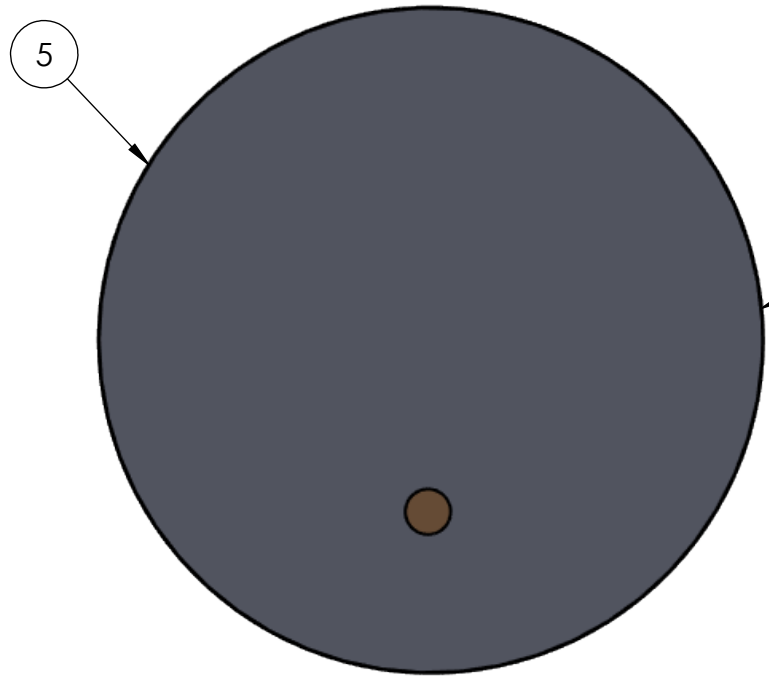

ENSURE THAT OUTER PERIMETER OF DESIGN-ASM-00001 FALLS WITHIN OUTER PERIMETER OF DESIGN-COM-00003

| | | | |
|--|------------------------------|---------------------|-----|
|  | DESCRIPTION | | |
| | Assembly, Temp Shield Module | | |
| <small>THIS DRAWING, IN TOTAL OR IN PART, IS PRIVATE AND CONFIDENTIAL AND IS SUPPLIED ONLY ON THE EXPRESS CONDITION THAT IT IS NOT TO BE USED BY, COPIED BY, OR COMMUNICATED TO, ANY OTHER PERSON WITHOUT WRITTEN AUTHORIZATION FROM SUNRISE LABS, INC. 25 CONSTITUTION DRIVE, BEDFORD, NH 03110</small> | CLIENT CODE | PART NUMBER | REV |
| | SIZE B | DESIGN-ASM-00009-03 | 03 |
| | SCALE 2:1 | SHEET 4 of 4 | |