



FCC/IC - TEST REPORT

Report Number : **709502255205-00A** Date of Issue: November 17, 2022

Model : MPA2C3, MPA2C3-4, MPA2MPSU, MPA4MPSU

Product Type : Access control unit

Applicant : Honeywell International Inc

Address : 12 Clintonville Rd Northford Connecticut United States 06484

Manufacturer : Honeywell International Inc

Address : 12 Clintonville Rd Northford Connecticut United States 06484

Test Result : **Positive** **Negative**

Total pages including Appendices : 51



TÜV SÜD Certification and Testing (China) Co., Ltd. Shanghai Branch is a subcontractor to TÜV SÜD Product Service GmbH according to the principles outlined in ISO 17025.

TÜV SÜD Certification and Testing (China) Co., Ltd. Shanghai Branch reports apply only to the specific samples tested under stated test conditions. Construction of the actual test samples has been documented. It is the manufacturer's responsibility to assure that additional production units of this model are manufactured with identical electrical and mechanical components. The manufacturer/importer is responsible to the Competent Authorities in Europe for any modifications made to the production units which result in non-compliance to the relevant regulations. TÜV SÜD Certification and Testing (China) Co., Ltd. Shanghai Branch shall have no liability for any deductions, inferences or generalizations drawn by the client or others from TÜV SÜD Certification and Testing (China) Co., Ltd. Shanghai Branch issued reports.

This report is the confidential property of the client. As a mutual protection to our clients, the public and ourselves, extracts from the test report shall not be reproduced except in full without our written approval.



1 Table of Contents

1	Table of Contents	2
2	Details about the Test Laboratory	3
3	Description of the Equipment under Test	4
4	Summary of Test Standards	5
5	Summary of Test Results	6
6	General Remarks	7
7	Test Setups	8
8	Systems test configuration	11
9	Technical Requirement	12
9.1	Conducted Emission	12
9.2	Conducted peak output power	17
9.3	6dB bandwidth and 99% Occupied Bandwidth	20
9.4	Power spectral density	25
9.5	Spurious RF conducted emissions	28
9.6	Band edge	35
9.7	Spurious radiated emissions for transmitter	40
10	Test Equipment List	48
11	System Measurement Uncertainty	49
12	Photographs of Test Set-ups	50
13	Photographs of EUT	50
14	Appendix	51



2 Details about the Test Laboratory

Test Site 1

Company name: TÜV SÜD Certification and Testing (China) Co., Ltd. Shanghai Branch
No.16 Lane, 1951 Du Hui Road,
Shanghai 201108,
P.R. China

Test Firm FCC
Registration
Number: 820234

Designation
number: CN1183

IC Company
Number: 25988

CAB identifier: CN0101

Telephone: +86 21 6141 0123
Fax: +86 21 6140 8600



3 Description of the Equipment under Test

Description of the Equipment Under Test

Product: Access control unit

PMN / HVIN / Model no.: MPA2C3, MPA2C3-4, MPA2MPSU, MPA4MPSU

FCC ID: 2A8LTMPA24

IC: 1609A-MPA24

Rating: Refer to appendix

RF Transmission Frequency: Bluetooth LE:2402~2480MHz

No. of Operated Channel: Bluetooth LE:40

Modulation: GFSK

Channel list:

Bluetooth Low Energy							
Ch	Fre(MHz)	Ch	Fre(MHz)	Ch	Fre(MHz)	Ch	Fre(MHz)
0	2402	10	2422	20	2442	30	2462
1	2404	11	2424	21	2444	31	2464
2	2406	12	2426	22	2446	32	2466
3	2408	13	2428	23	2448	33	2468
4	2410	14	2430	24	2450	34	2470
5	2412	15	2432	25	2452	35	2472
6	2414	16	2434	26	2454	36	2474
7	2416	17	2436	27	2456	37	2476
8	2418	18	2438	28	2458	38	2478
9	2420	19	2440	29	2460	39	2480

Antenna Type: PCB antenna

Antenna Gain: 3.9dBi

Description of the EUT: The Equipment Under Test (EUT) is an Access control unit with 2.4GHz BLE function (support 1Mbps and 2Mbps data rate). Detail information refer to appendix.

The sample's mentioned in this report is/are submitted/ supplied/ manufactured by client. The laboratory therefore assumes no responsibility for accuracy of information on the brand name, model number, origin of manufacture, consignment or any information supplied.



4 Summary of Test Standards

Test Standards	
FCC Part 15 Subpart C	PART 15 - RADIO FREQUENCY DEVICES Subpart C - Intentional Radiators
RSS-Gen Issue 5 Amendment 2 February 2021	General Requirements for Compliance of Radio Apparatus
RSS-247 Issue 2 February 2017	Digital Transmission Systems (DTSS), Frequency Hopping Systems (FHSS) and License-Exempt Local Area Network (LE-LAN) Devices

All the test methods were according to KDB 558074 D01 15.247 Meas Guidance v05r02 and ANSI C63.10 (2013).



5 Summary of Test Results

Technical Requirements						
Test Condition	Pages	Test Site	Test Result			
			Pass	Fail	N/A	
§15.207 & RSS-GEN 8.8	Conducted emission AC power port	12-16	Site 1	<input checked="" type="checkbox"/>	<input type="checkbox"/>	<input type="checkbox"/>
§15.247 (b) (1) & RSS-247 5.4(d)	Conducted peak output power	17-19	Site 1	<input checked="" type="checkbox"/>	<input type="checkbox"/>	<input type="checkbox"/>
§15.247(a)(1) & RSS-247 5.1(b)	20dB bandwidth	---	---	<input type="checkbox"/>	<input type="checkbox"/>	<input checked="" type="checkbox"/>
§15.247(a)(1) & RSS-247 5.1(b)	Carrier frequency separation	---	---	<input type="checkbox"/>	<input type="checkbox"/>	<input checked="" type="checkbox"/>
§15.247(a)(1)(iii) & RSS-247 5.1(d)	Number of hopping frequencies	---	---	<input type="checkbox"/>	<input type="checkbox"/>	<input checked="" type="checkbox"/>
§15.247(a)(1)(iii) & RSS-247 5.1(d)	Dwell Time	---	---	<input type="checkbox"/>	<input type="checkbox"/>	<input checked="" type="checkbox"/>
§15.247(a)(2) & RSS-247 5.2(a) & RSS-GEN 6.7	6dB bandwidth and 99% Occupied Bandwidth	20-24	Site 1	<input checked="" type="checkbox"/>	<input type="checkbox"/>	<input type="checkbox"/>
§15.247(e) & RSS-247 5.2(b)	Power spectral density	25-27	Site 1	<input checked="" type="checkbox"/>	<input type="checkbox"/>	<input type="checkbox"/>
§15.247(d) & RSS-247 5.5	Spurious RF conducted emissions	28-34	Site 1	<input checked="" type="checkbox"/>	<input type="checkbox"/>	<input type="checkbox"/>
§15.247(d) & RSS-247 5.5	Band edge	35-39	Site 1	<input checked="" type="checkbox"/>	<input type="checkbox"/>	<input type="checkbox"/>
§15.247(d) & §15.209 & RSS-247 5.5 & RSS-Gen 6.13	Spurious radiated emissions for transmitter	40-47	Site 1	<input checked="" type="checkbox"/>	<input type="checkbox"/>	<input type="checkbox"/>
§15.203 & RSS-Gen 6.8	Antenna requirement	See note 1		<input checked="" type="checkbox"/>	<input type="checkbox"/>	<input type="checkbox"/>

Remark 1: N/A – Not Applicable.

Note 1: The EUT uses a PCB antenna, which gain is 3.9dBi. In accordance to §15.203, It is considered sufficiently to comply with the provisions of this section.



6 General Remarks

Remarks

This submittal(s) (test report) is intended for FCC ID: 2A8LTMPA24, IC: 1609A-MPA24 complies with Section 15.207,15.209,15.231,15.247 of the FCC Part 15, Subpart C Rules and RSS-247, RSS-GEN.

SUMMARY:

All tests according to the regulations cited on page 5 were

- Performed

- **Not** Performed

The Equipment under Test

- **Fulfills** the general approval requirements.

- **Does not** fulfill the general approval requirements.

Sample Received Date: October 10, 2022

Testing Start Date: October 18, 2022

Testing End Date: October 24, 2022

-TÜV SÜD Certification and Testing (China) Co., Ltd. Shanghai Branch

Reviewed by:

Prepared by:

Tested by:

Hui TONG
Review Engineer



Jiayi XU
Project Engineer

Cheng Huali
Test Engineer

7 Test Setups

7.1 AC Power Line Conducted Emission test setups

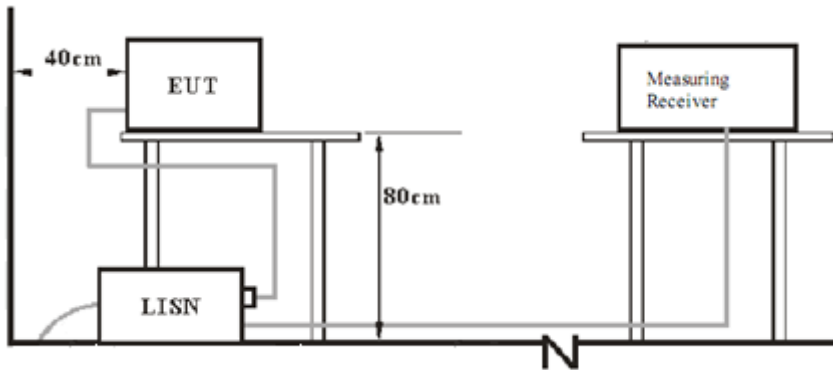

7.2 Radiated test setups

9kHz ~ 30MHz Test Setup:

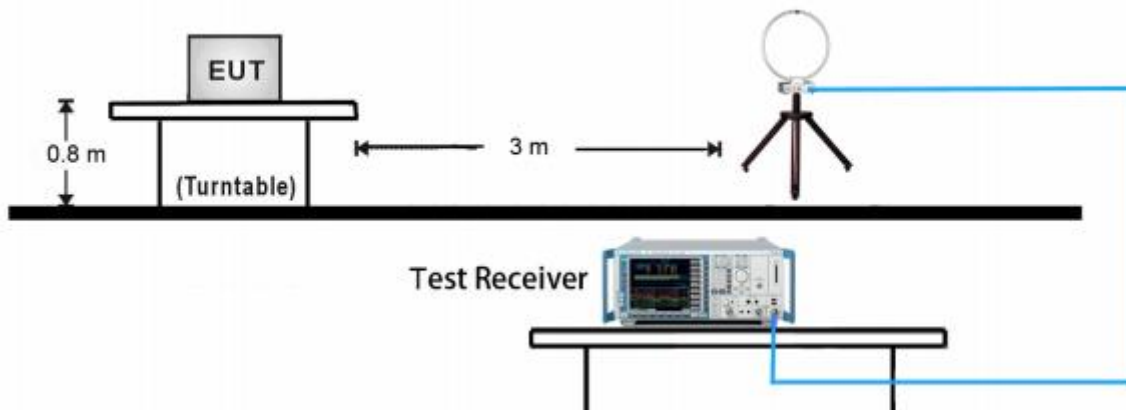

30MHz ~ 1GHz Test Setup:

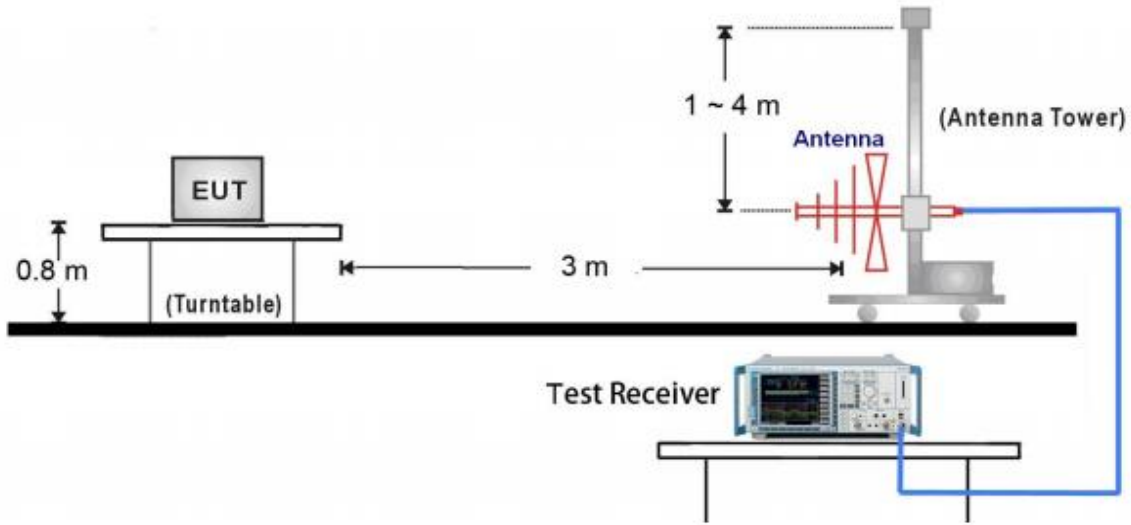

1GHz ~ 18GHz Test Setup:

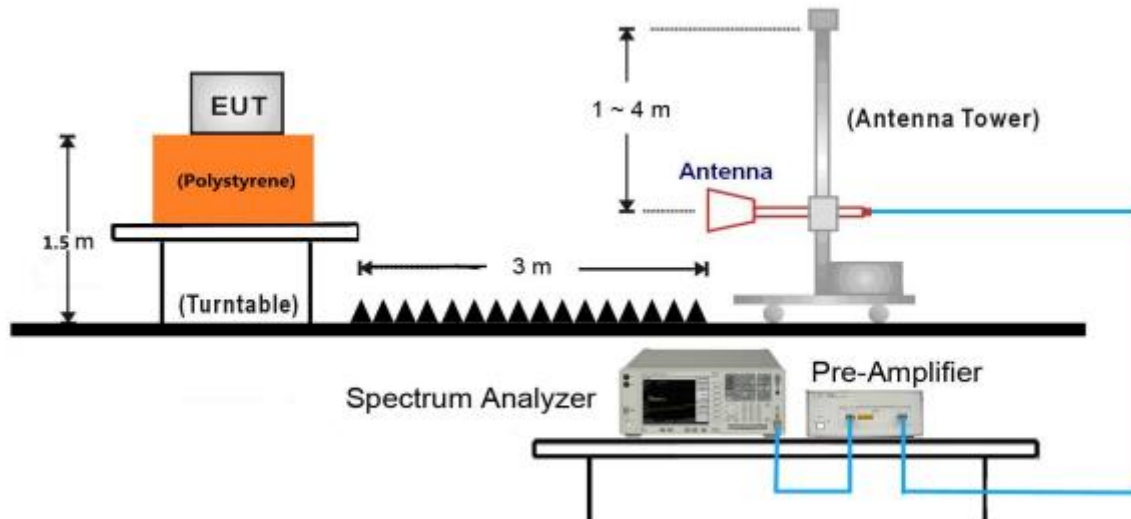

18GHz ~ 40GHz Test Setup:

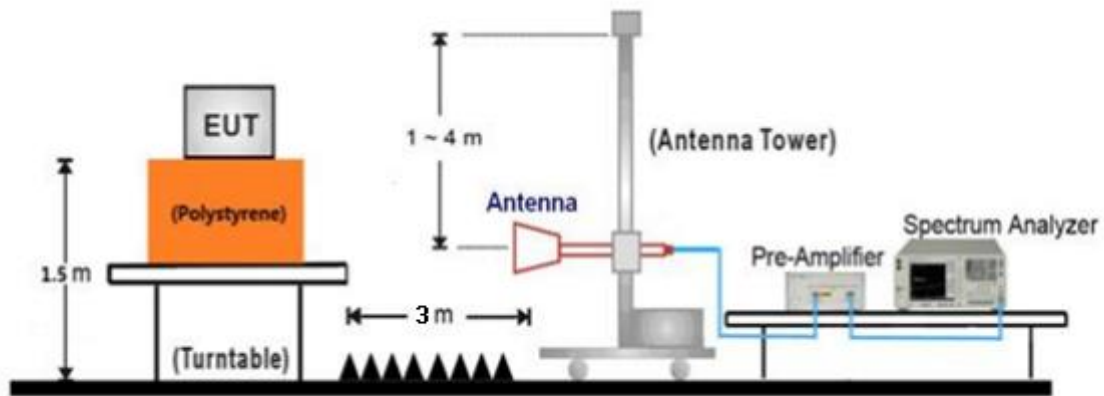

7.3 Conducted RF test setups

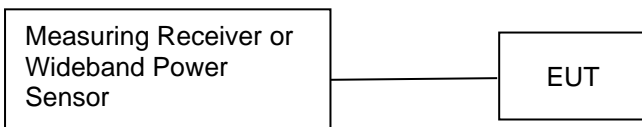



8 Systems test configuration

Auxiliary Equipment Used during Test:

DESCRIPTION	MANUFACTURER	MODEL NO.(SHIELD)	S/N(LENGTH)
Notebook	Lenove	E470	PF-OU5TS7 17/09

Test software: J-BlueC

The system was configured to channel 0, 19, and 39 for the test.

Non-hopping mode: The system was configured to operate at a signal channel transmitting. The test software allows the configuration and operation at the worst-case duty and the highest transmit power.

9 Technical Requirement

9.1 Conducted Emission

Test Method

1. The EUT was placed on a table, which is 0.8m above ground plane
2. The power line of the EUT is connected to the AC mains through a Artificial Mains Network (A.M.N.).
3. Maximum procedure was performed to ensure EUT compliance
4. A EMI test receiver is used to test the emissions from both sides of AC line

Limit

Frequency MHz	QP Limit dB μ V	AV Limit dB μ V
0.150-0.500	66-56*	56-46*
0.500-5	56	46
5-30	60	50

Decreasing linearly with logarithm of the frequency

Conducted Emission

150k-30MHz Conducted Emission Test

EUT Information

EUT Name: Access control unit
 Model: MPA4MPSU
 Client: Honeywell International Inc
 Op Cond: Power on, AC 110V/60Hz, TX_2440MHz,2Mbps, T21.3, H45.2%, P101.9kPa
 Operator: Cheng Huali
 Standard: CRF 47 Part 15.247
 Comment: Phase L
 Sample No.: SHA-681658-1

Scan Setup: Voltage with 2-Line-LISN pre [EMI conducted]

Hardware Setup: Voltage with 2-Line-LISN
 Receiver: [ESR 3]
 Level Unit: dBuV

Subrange	Step Size	Detectors	IF BW	Meas. Time	Preamp
9 kHz - 150 kHz	100 Hz	PK+	200 Hz	0.02 s	0 dB
150 kHz - 30 MHz	4.5 kHz	PK+; AVG	9 kHz	0.01 s	0 dB

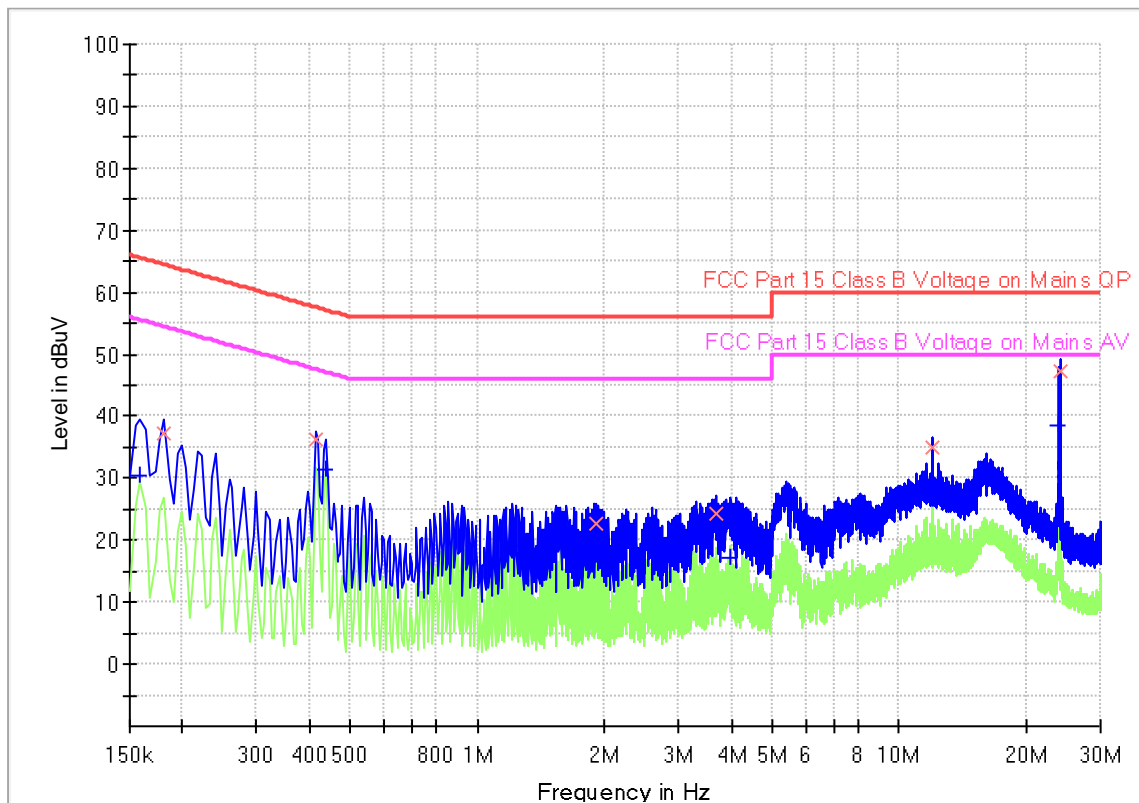



Final Result

Frequency (MHz)	QuasiPeak (dBuV)	CAverage (dBuV)	Limit (dBuV)	Margin (dB)	Meas. Time (ms)	Bandwidth (kHz)	Line	Corr. (dB)
0.159000	---	30.47	55.52	25.05	1000.0	9.000	L1	19.5
0.181500	37.36	---	64.42	27.06	1000.0	9.000	L1	19.5
0.415500	36.19	---	57.54	21.35	1000.0	9.000	L1	19.5
0.438000	---	31.31	47.10	15.79	1000.0	9.000	L1	19.5
1.212000	---	19.19	46.00	26.81	1000.0	9.000	L1	19.5
1.905000	22.55	---	56.00	33.45	1000.0	9.000	L1	19.5
3.678000	24.19	---	56.00	31.81	1000.0	9.000	L1	19.6
3.975000	---	17.23	46.00	28.77	1000.0	9.000	L1	19.6
11.967000	---	26.41	50.00	23.59	1000.0	9.000	L1	19.7
12.039000	35.05	---	60.00	24.95	1000.0	9.000	L1	19.7
23.928000	---	38.54	50.00	11.46	1000.0	9.000	L1	20.0
24.076500	47.38	---	60.00	12.62	1000.0	9.000	L1	20.0

Note 1: Measure Level (dBuV/m) = Reading Level (dBuV) + Factor (dB)
 Factor (dB) = Cable Loss (dB) + LISN Factor (dB) + 10dB Attenuator



150k-30MHz Conducted Emission Test

EUT Information

EUT Name: Access control unit
 Model: MPA4MPSU
 Client: Honeywell International Inc
 Op Cond: Power on, AC 110V/60Hz, TX_2440MHz,2Mbps, T21.3, H45.2%, P101.9kPa
 Operator: Cheng Huali
 Standard: CRF 47 Part 15.247
 Comment: Phase N
 Sample No.: SHA-681658-1

Scan Setup: Voltage with 2-Line-LISN pre [EMI conducted]

Hardware Setup: Voltage with 2-Line-LISN
 Receiver: [ESR 3]
 Level Unit: dBuV

Subrange	Step Size	Detectors	IF BW	Meas. Time	Preamp
9 kHz - 150 kHz	100 Hz	PK+	200 Hz	0.02 s	0 dB
150 kHz - 30 MHz	4.5 kHz	PK+; AVG	9 kHz	0.01 s	0 dB

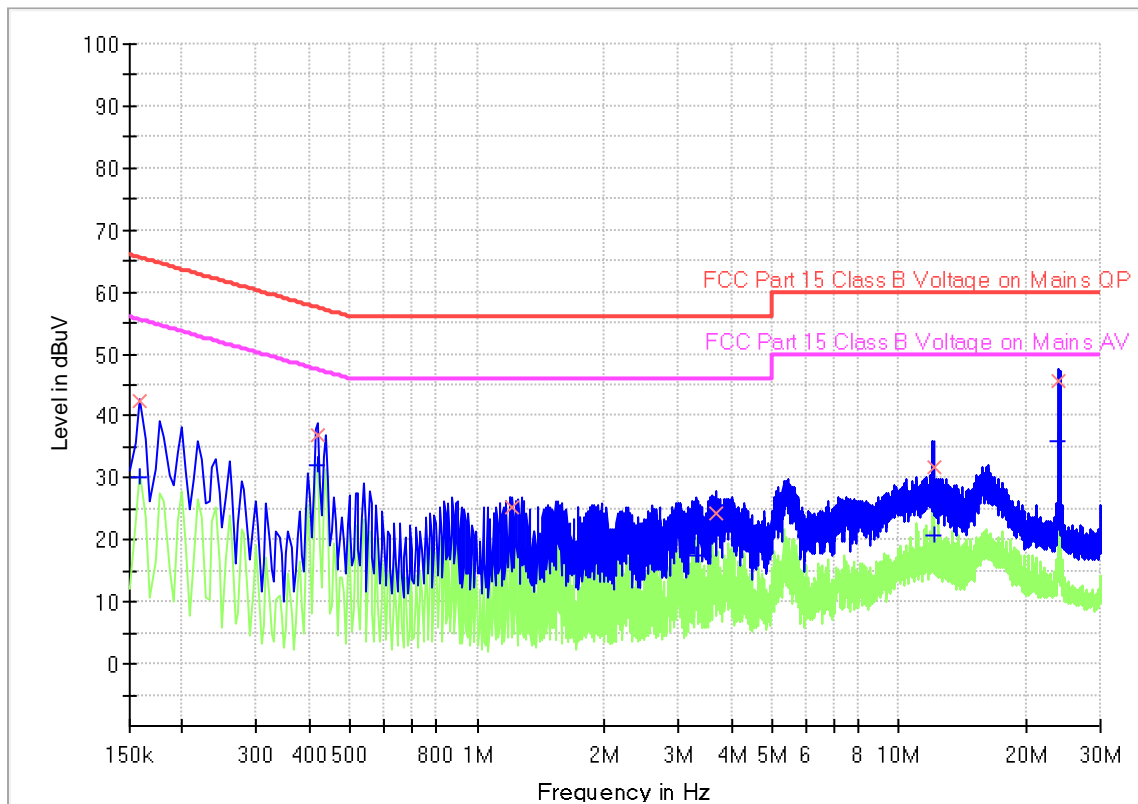



Final Result

Frequency (MHz)	QuasiPeak (dBuV)	CAverage (dBuV)	Limit (dBuV)	Margin (dB)	Meas. Time (ms)	Bandwidth (kHz)	Line	Corr. (dB)
0.159000	---	30.23	55.52	25.29	1000.0	9.000	N	19.5
0.159000	42.28	---	65.52	23.24	1000.0	9.000	N	19.5
0.420000	---	32.00	47.45	15.45	1000.0	9.000	N	19.5
0.420000	36.78	---	57.45	20.67	1000.0	9.000	N	19.5
1.212000	---	19.76	46.00	26.24	1000.0	9.000	N	19.5
1.212000	25.11	---	56.00	30.89	1000.0	9.000	N	19.5
3.318000	---	17.49	46.00	28.51	1000.0	9.000	N	19.5
3.678000	24.36	---	56.00	31.64	1000.0	9.000	N	19.5
12.052500	31.84	---	60.00	28.16	1000.0	9.000	N	19.7
12.052500	---	20.60	50.00	29.40	1000.0	9.000	N	19.7
23.946000	---	35.88	50.00	14.12	1000.0	9.000	N	20.0
23.946000	45.63	---	60.00	14.37	1000.0	9.000	N	20.0

Note 1: Measure Level (dBuV/m) = Reading Level (dBuV) + Factor (dB)
 Factor (dB) = Cable Loss (dB) + LISN Factor (dB) + 10dB Attenuator



9.2 Conducted peak output power

Test Method

1. Use the following spectrum analyzer settings:
 RBW > the 6 dB bandwidth of the emission being measured, VBW≥3RBW, Span≥3RBW
 Sweep = auto, Detector function = peak, Trace = max hold.
2. Add a correction factor to the display.
3. Use a power meter to measure the conducted peak output power.

Limits

According to §15.247 (b) (1) & RSS-247 5.4(d), conducted peak output power limit as below:

Conducted peak output power

Frequency Range MHz	Limit W	Limit dBm
2400-2483.5	≤1	≤30
e.i.r.p		
Frequency Range MHz	Limit W	Limit dBm
2400-2483.5	≤4	≤36

Test result as below table

Antenna gain=3.9dBi							
Data transmission Rate	Frequency (MHz)	Conducted Peak Output Power (dBm) §15.247 (b) (1)			e.i.r.p. (dBm) RSS-247 5.4(d)		
		Result	limit	Verdict	Result	limit	Verdict
1Mbps	2402MHz	5.62	≤30	Pass	9.52	≤36	Pass
	2440MHz	5.93	≤30	Pass	9.83	≤36	Pass
	2480MHz	5.79	≤30	Pass	9.69	≤36	Pass
2Mbps	2402MHz	5.64	≤30	Pass	9.54	≤36	Pass
	2440MHz	5.93	≤30	Pass	9.83	≤36	Pass
	2480MHz	5.80	≤30	Pass	9.70	≤36	Pass



Peak output power (1Mbps)

Channel 0 (2402MHz)

Channel 19 (2440MHz)

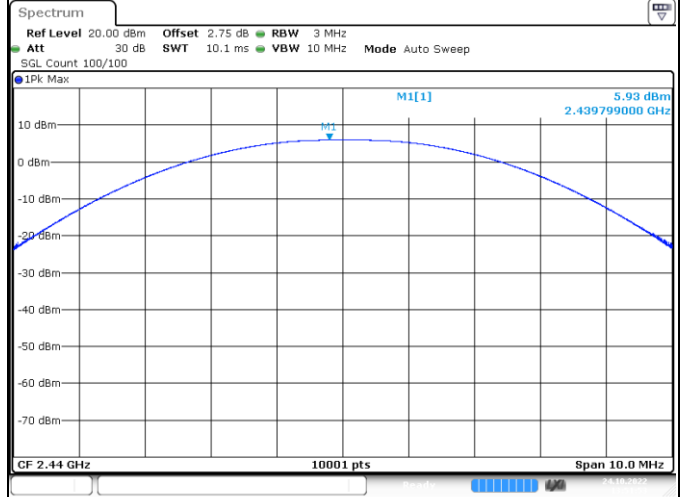
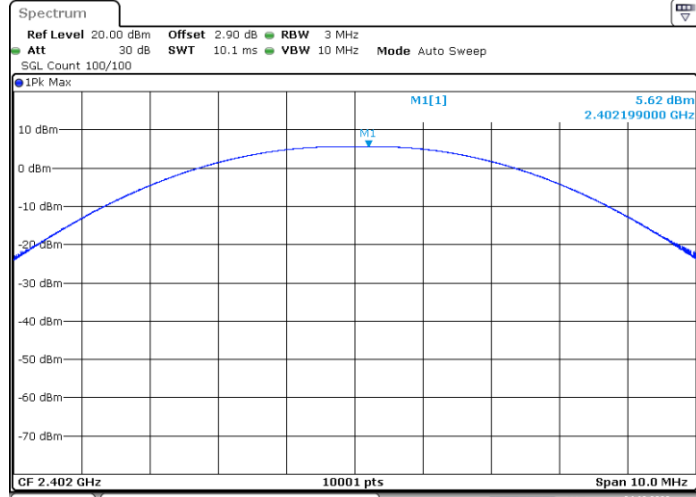

Date: 24.OCT.2022 13:50:55

Date: 24.OCT.2022 13:51:53

Channel 39 (2480MHz)

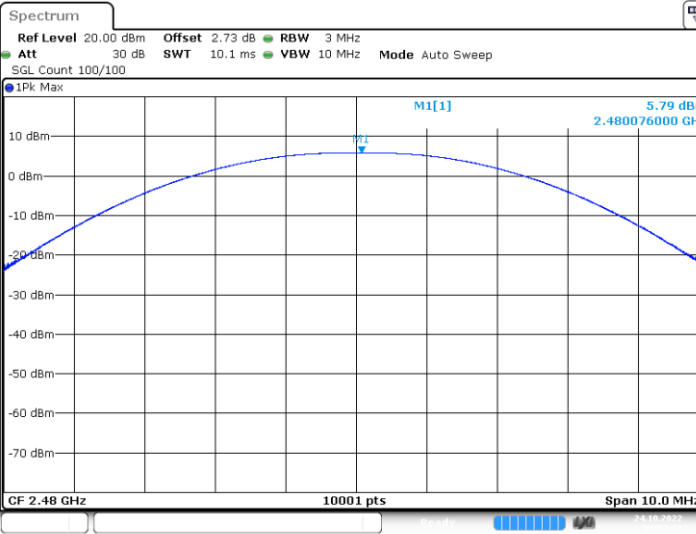

Date: 24.OCT.2022 13:53:16



Peak output power (2Mbps)

Channel 0 (2402MHz)

Channel 19 (2440MHz)

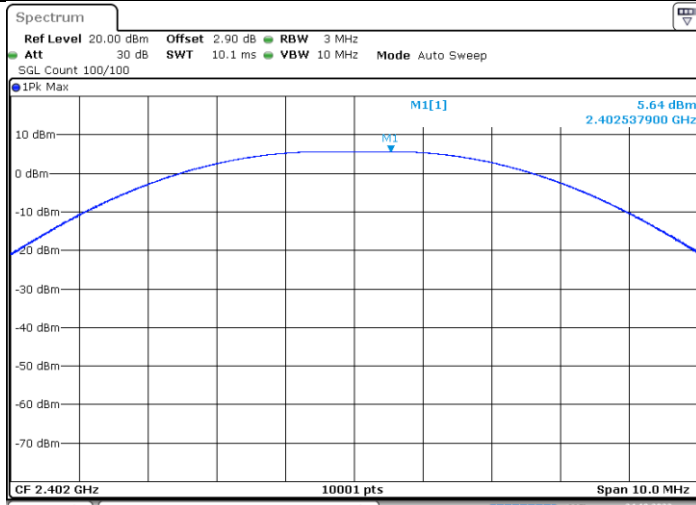

Date: 24.OCT.2022 13:54:55

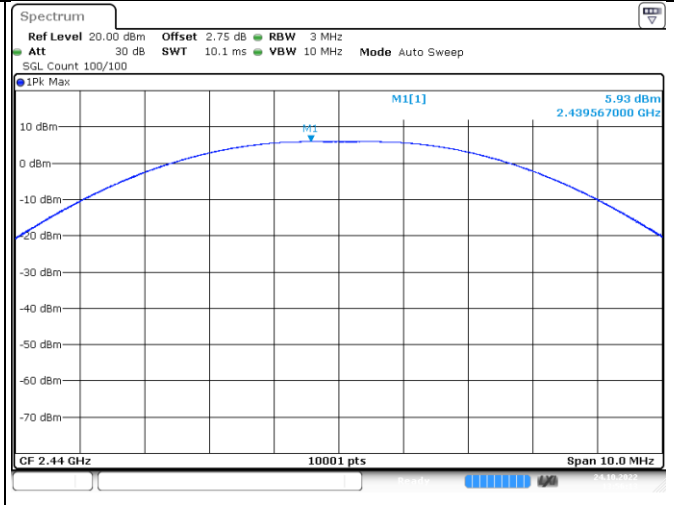

Date: 24.OCT.2022 13:56:14

Channel 39 (2480MHz)

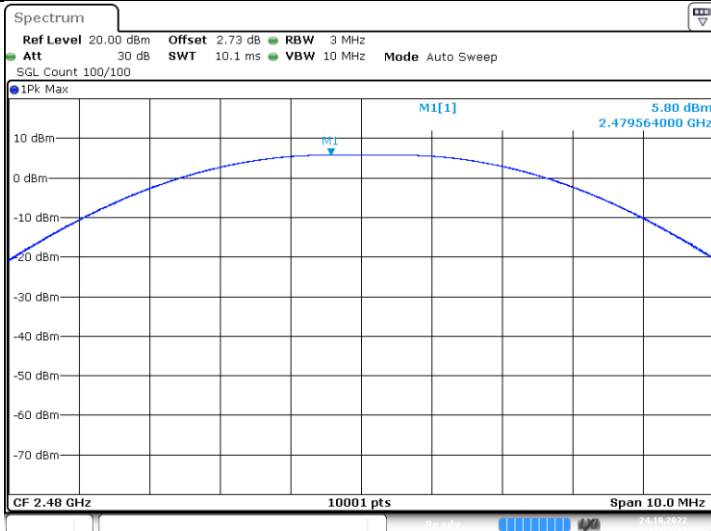

Date: 24.OCT.2022 13:57:15



9.3 6dB bandwidth and 99% Occupied Bandwidth

Test Method

1. Use the following spectrum analyzer settings:
RBW=100K, VBW≥3RBW, Sweep = auto, Detector function = peak, Trace = max hold
2. Use the automatic bandwidth measurement capability of an instrument, may be employed using the X dB bandwidth mode with X set to 6 dB, care shall be taken so that the bandwidth measurement is not influenced by any intermediate power nulls in the fundamental emission that might be ≥ 6 dB.
3. Allow the trace to stabilize, record the X dB Bandwidth value.

Limit

Limit [kHz]

≥500

Test Method for 99 % Bandwidth

1. Use the following spectrum analyzer settings:
RBW=1% to 5% of the actual occupied, VBW≥3RBW, Sweep = auto, Detector function = peak, Trace = max hold
2. Use the automatic bandwidth measurement capability of an instrument, care shall be taken so that the bandwidth measurement is not influenced by any intermediate power nulls in the fundamental emission that might be ≥ 6 dB.
3. Allow the trace to stabilize, record the X dB Bandwidth value.

Limit

Limit [kHz]

N/A

Test result

Data transmission rate	Frequency MHz	6dB bandwidth (MHz)		Result	99% occupied bandwidth MHz
		result	limit	verdict	
1Mbps	2402	0.681	≥0.5	Pass	1.033
	2440	0.686	≥0.5	Pass	1.041
	2480	0.720	≥0.5	Pass	1.037
2Mbps	2402	0.947	≥0.5	Pass	2.022
	2440	1.127	≥0.5	Pass	2.035
	2480	1.061	≥0.5	Pass	2.027



6dB Bandwidth

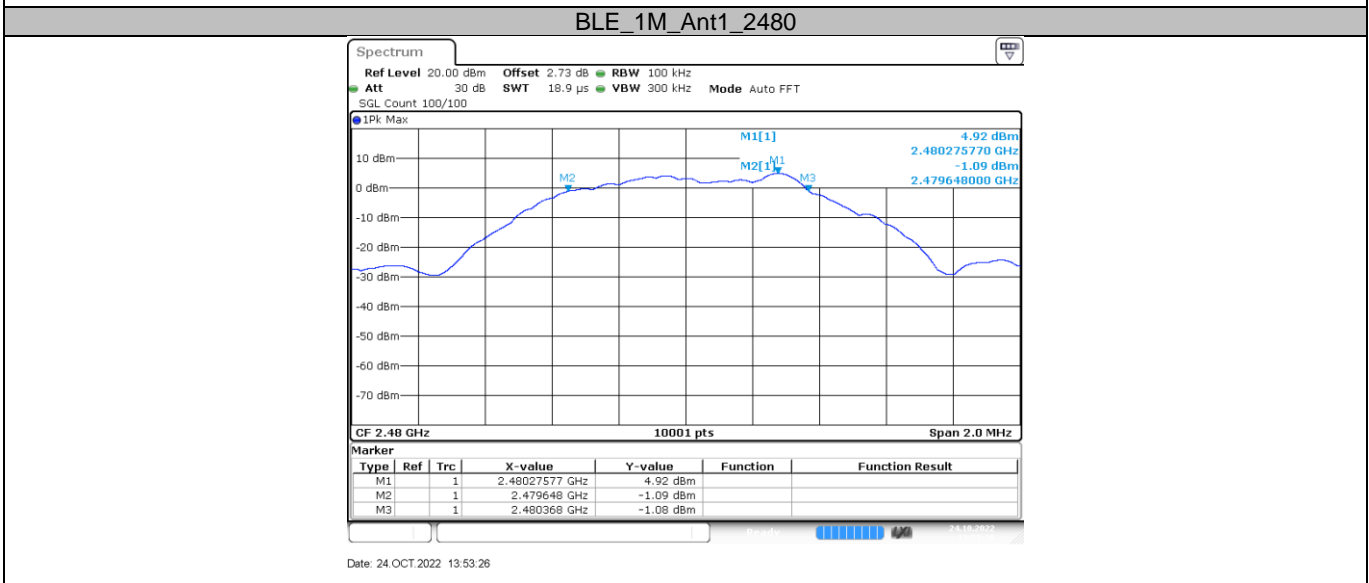
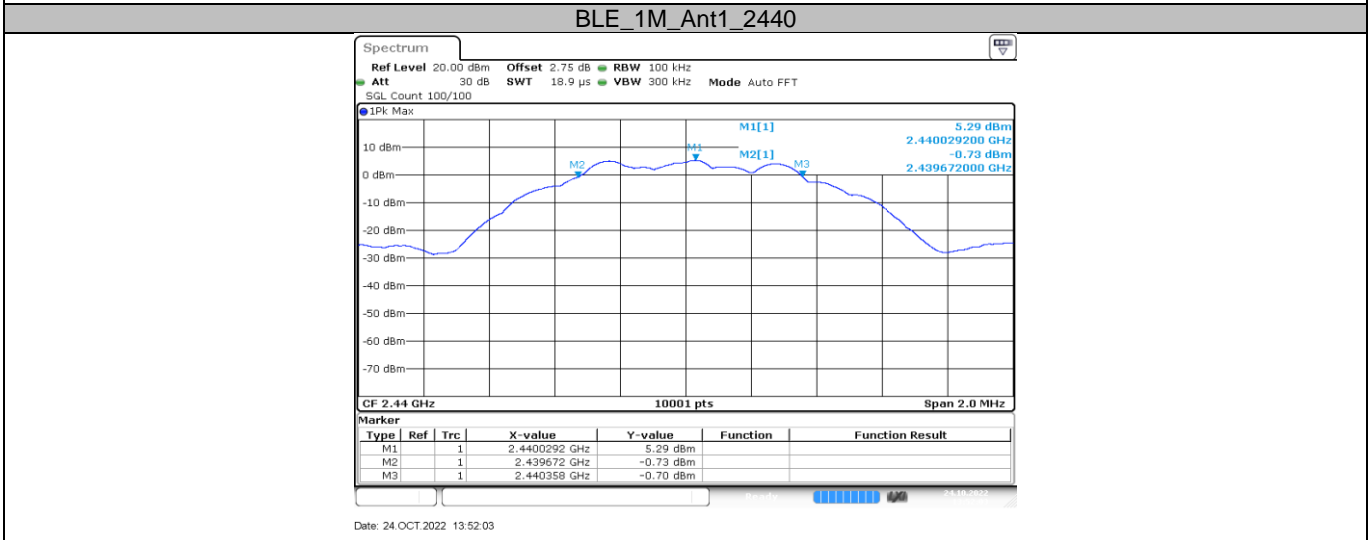
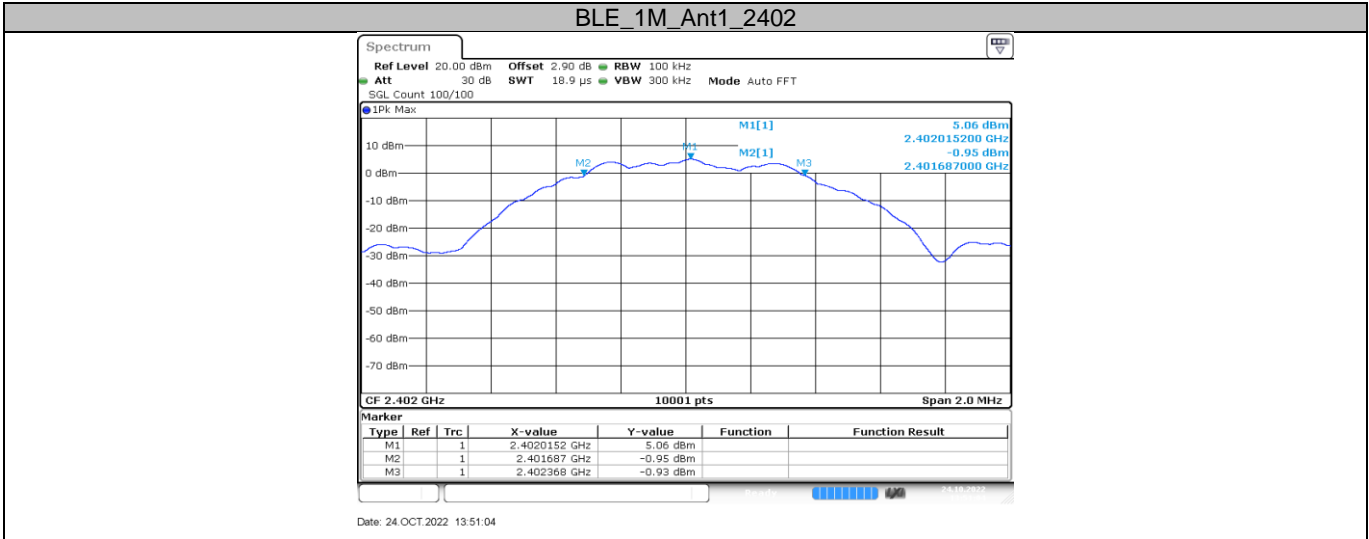



BLE_2M_Ant1_2402

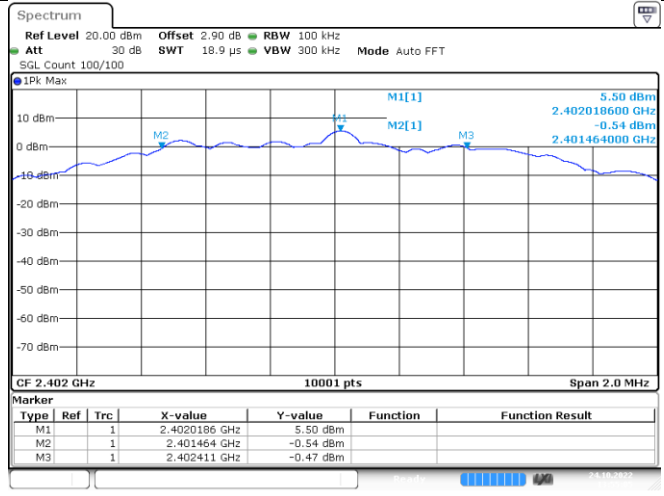

Date: 24.OCT.2022 13:55:06

BLE_2M_Ant1_2440

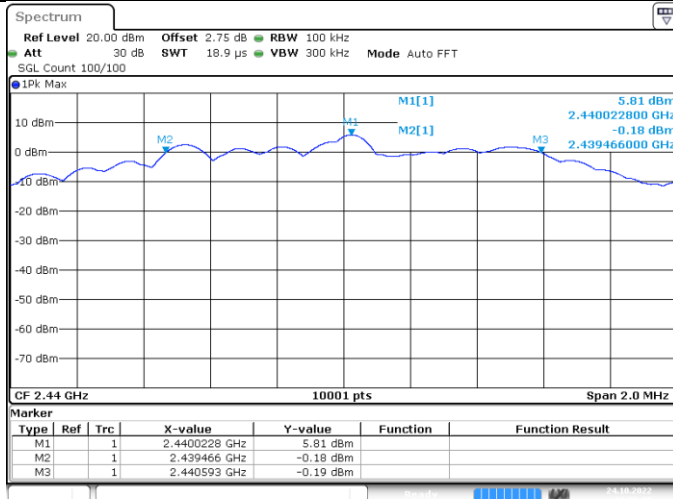

Date: 24.OCT.2022 13:56:25

BLE_2M_Ant1_2480

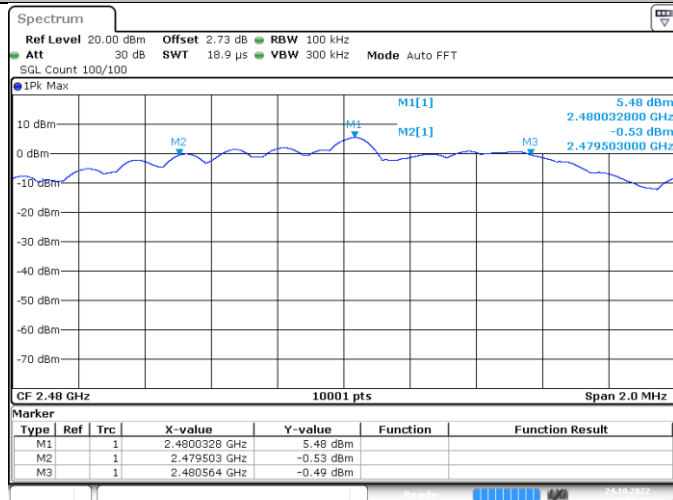

Date: 24.OCT.2022 13:57:27



99% Bandwidth

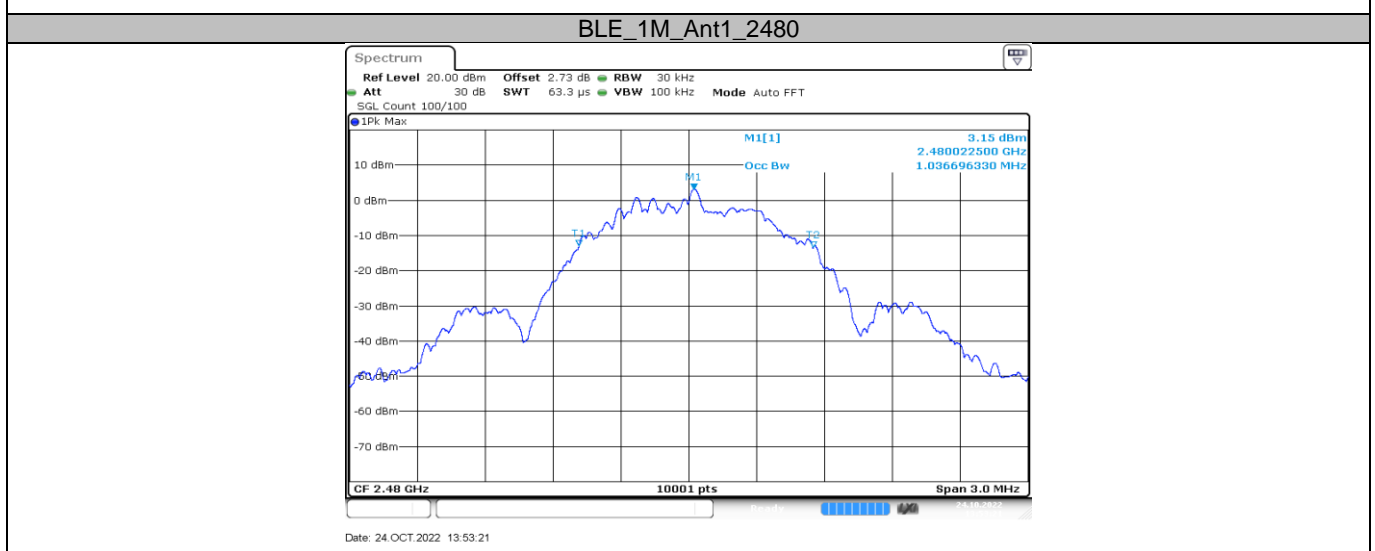
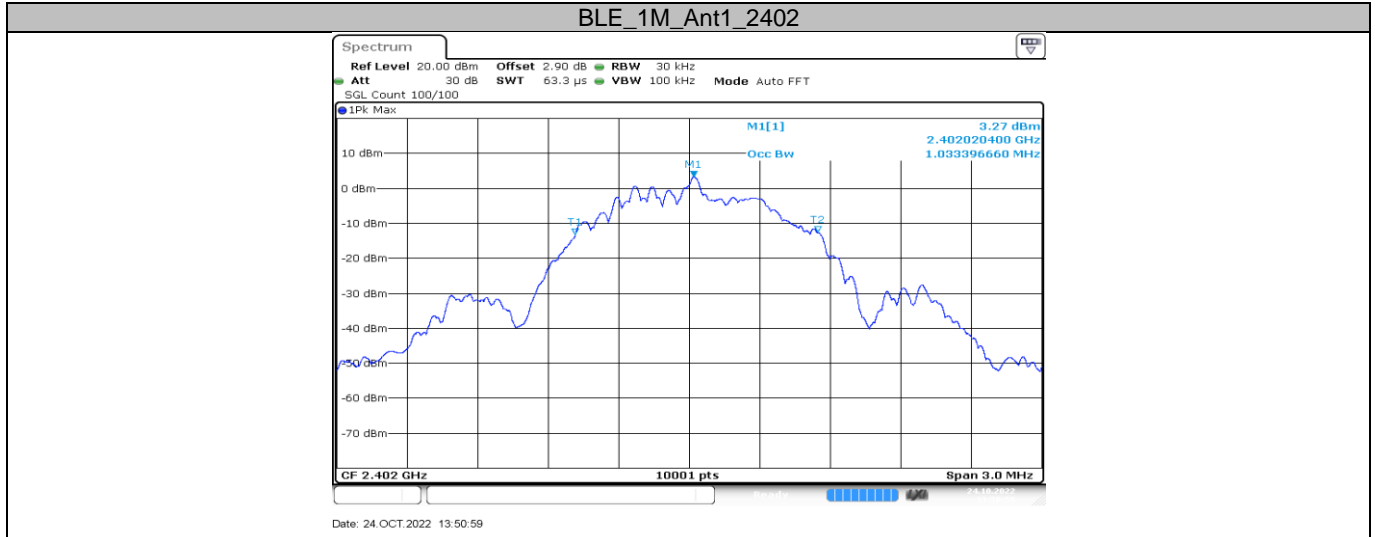

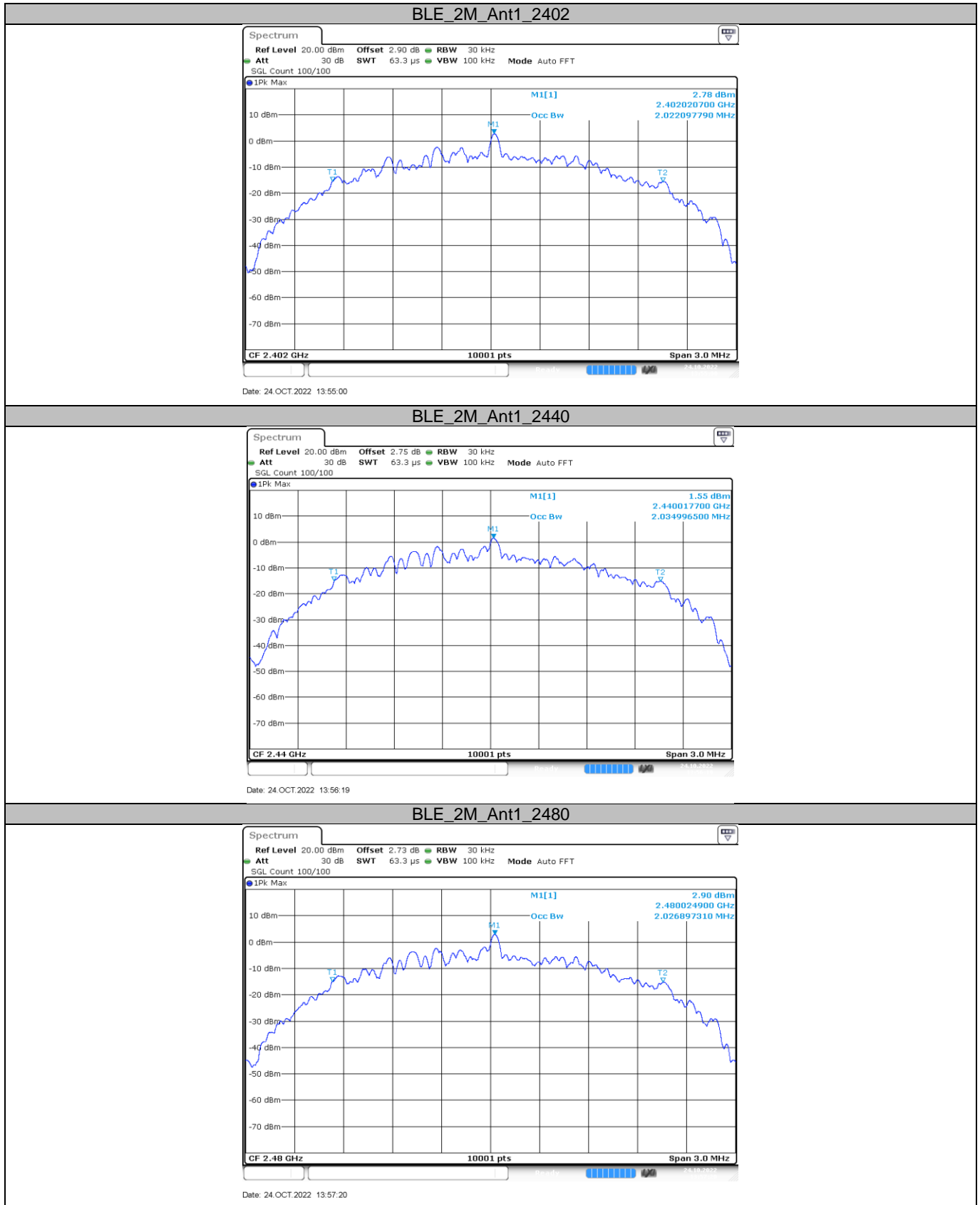



9.4 Power spectral density

Test Method

This procedure shall be used if maximum peak conducted output power was used to demonstrate compliance:

1. Set analyzer center frequency to DTS channel center frequency.
RBW=3kHz,VBW≥3RBW,Span=1.5 times DTS bandwidth, Detector=Peak, Sweep=auto, Trace= max hold.
2. Allow trace to fully stabilize, use the peak marker function to determine the maximum amplitude level within the RBW.
3. Repeat above procedures until other frequencies measured were completed.

Limit

Limit [dBm/3kHz]

≤8

Test result

Data transmission rate	Frequency	Power spectral density	Result
1Mbps	MHz	dBm/3kHz	
	Top channel 2402MHz	-9.75	Pass
	Middle channel 2440MHz	-9.73	Pass
	Bottom channel 2480MHz	-9.96	Pass
2Mbps	Top channel 2402MHz	-12.33	Pass
	Middle channel 2440MHz	-12.07	Pass
	Bottom channel 2480MHz	-12.35	Pass



PK PSD (1Mbps)

Channel 0 (2402MHz)

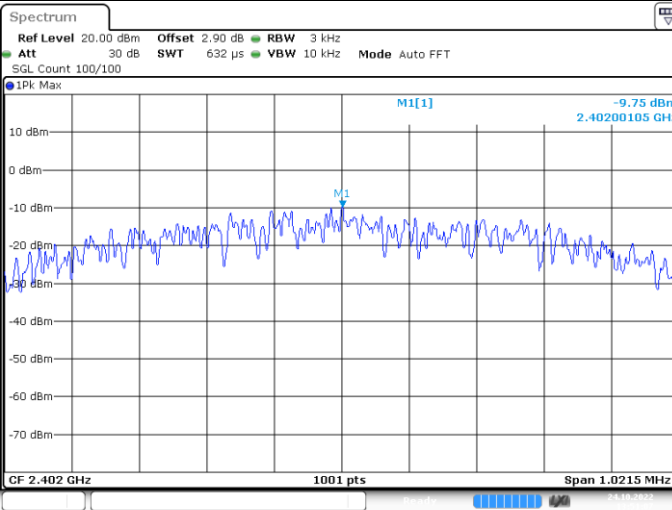

Date: 24.OCT.2022 13:51:07

Channel 19 (2440MHz)

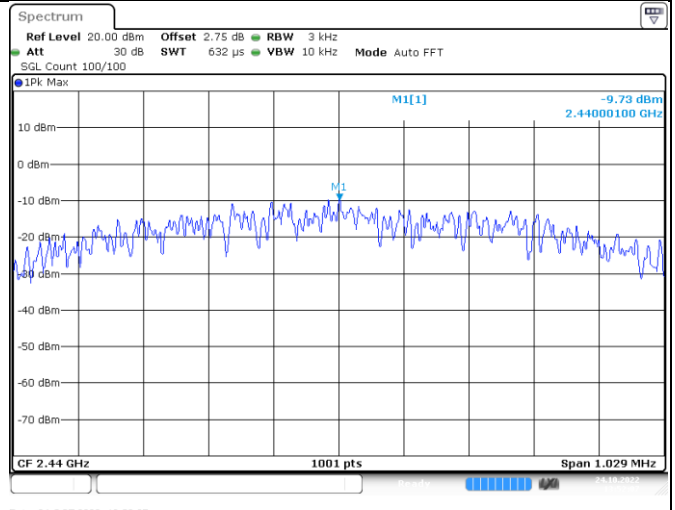

Date: 24.OCT.2022 13:52:07

Channel 39 (2480MHz)

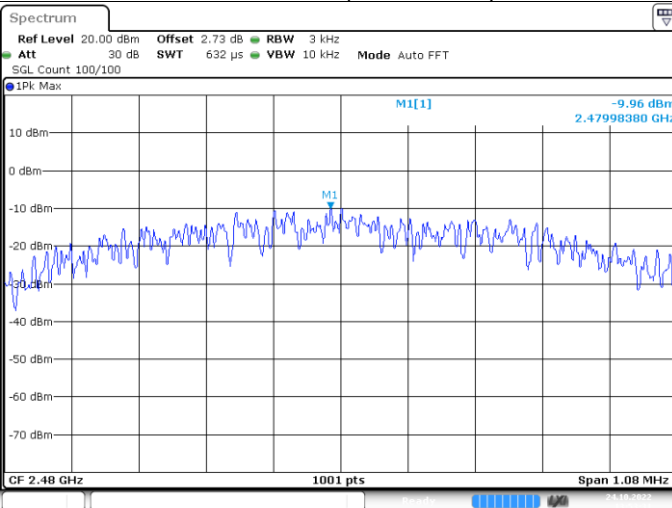

Date: 24.OCT.2022 13:53:31



PK PSD (2Mbps)

Channel 0 (2402MHz)

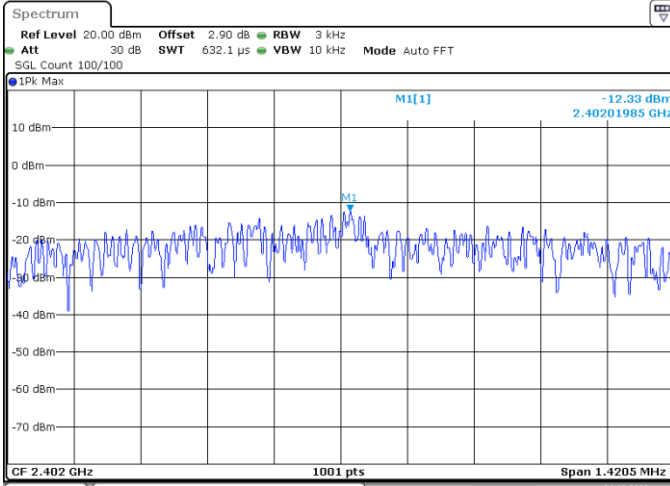

Date: 24.OCT.2022 13:55:11

Channel 19 (2440MHz)

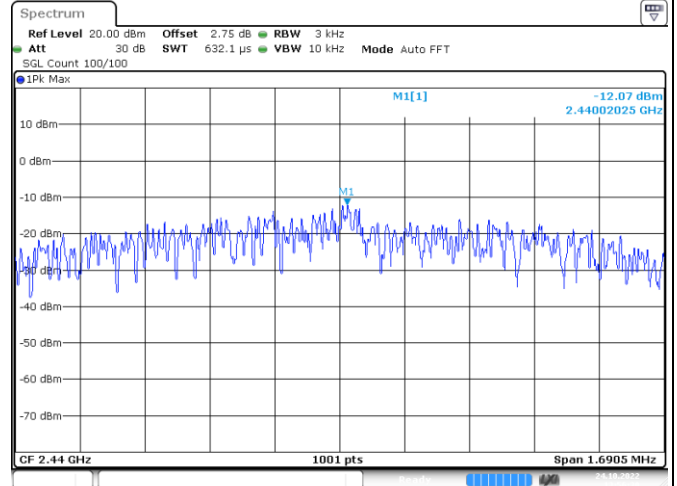

Date: 24.OCT.2022 13:56:31

Channel 39 (2480MHz)

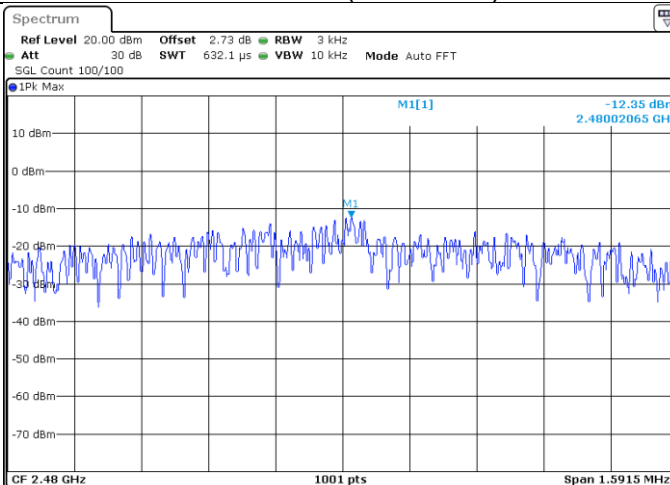

Date: 24.OCT.2022 13:57:32



9.5 Spurious RF conducted emissions

Test Method

1. Establish a reference level by using the following procedure:
 - a. Set RBW=100 kHz. VBW \geq 3RBW. Detector =peak, Sweep time = auto couple, Trace mode = max hold.
 - b. Allow trace to fully stabilize, use the peak marker function to determine the maximum PSD level.
2. Use the maximum PSD level to establish the reference level.
 - a. Set the center frequency and span to encompass frequency range to be measured.
 - b. Use the peak marker function to determine the maximum amplitude level. Ensure that the amplitude of all unwanted emissions outside of the authorized frequency band (excluding restricted frequency bands) are attenuated by at least the minimum requirements, report the three highest emissions relative to the limit.
3. Repeat above procedures until other frequencies measured were completed.

Limit

Frequency Range MHz	Limit (dBc)
30-25000	-20



Spurious RF conducted emissions

Out-of-Band Emissions (1Mbps)

Channel 0 (2402MHz)

Reference point

Spurious Emission (30MHz – 1GHz)

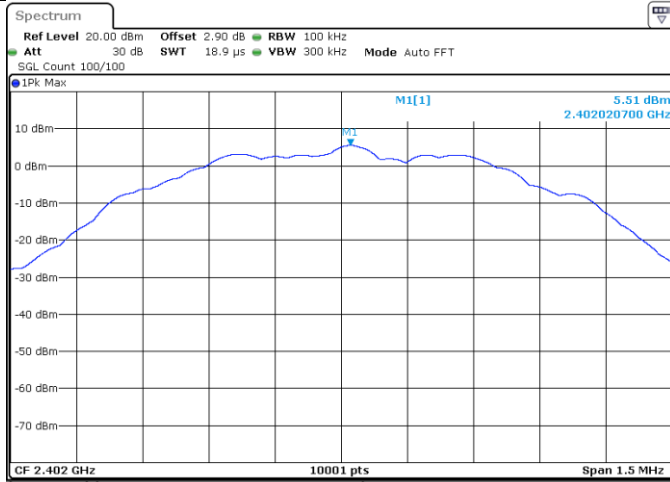

Date: 24.OCT.2022 13:51:17

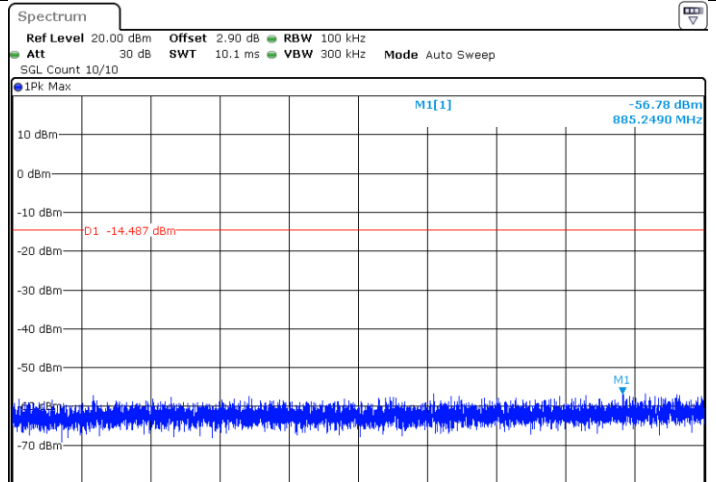

Date: 24.OCT.2022 13:51:19

Spurious Emission (1GHz – 5GHz)

Spurious Emission (5GHz – 26.5GHz)

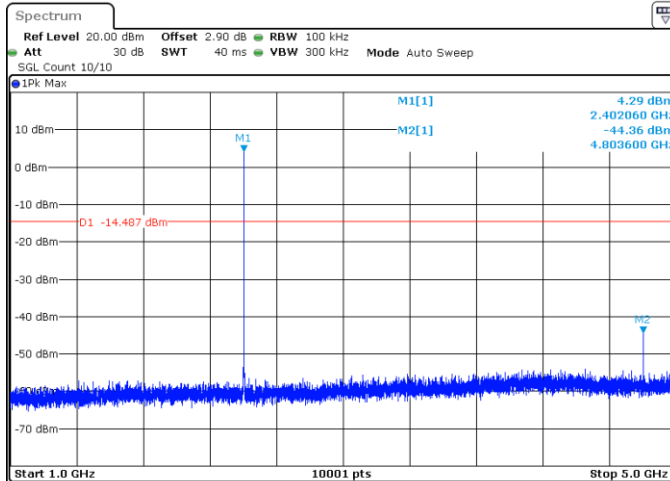

Date: 24.OCT.2022 13:51:21

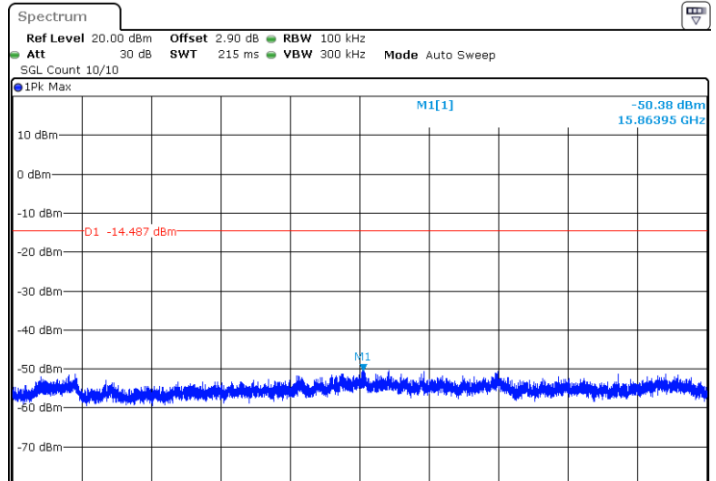

Date: 24.OCT.2022 13:51:30



Out-of-Band Emissions (1Mbps)
Channel 19 (2440MHz)

Reference point

Spurious Emission (30MHz – 1GHz)

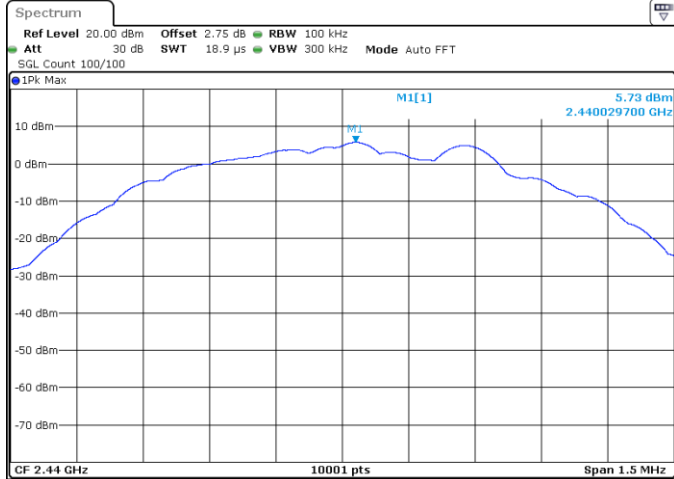

Date: 24.OCT.2022 13:52:10

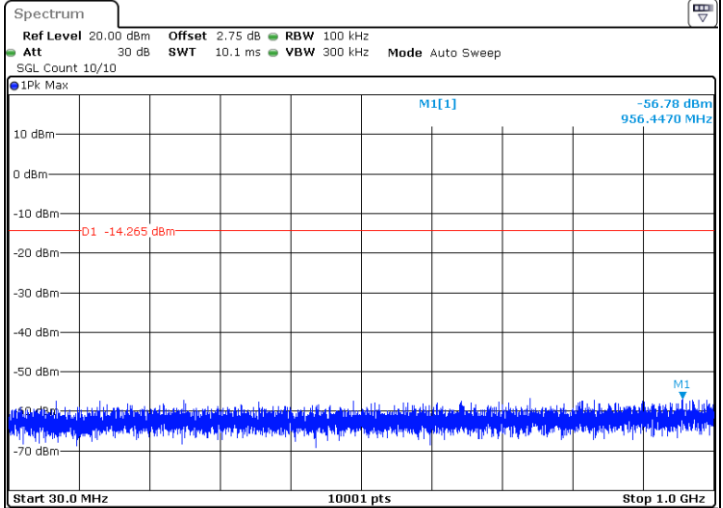

Date: 24.OCT.2022 13:52:12

Spurious Emission (1GHz – 5GHz)

Spurious Emission (5GHz – 26.5GHz)

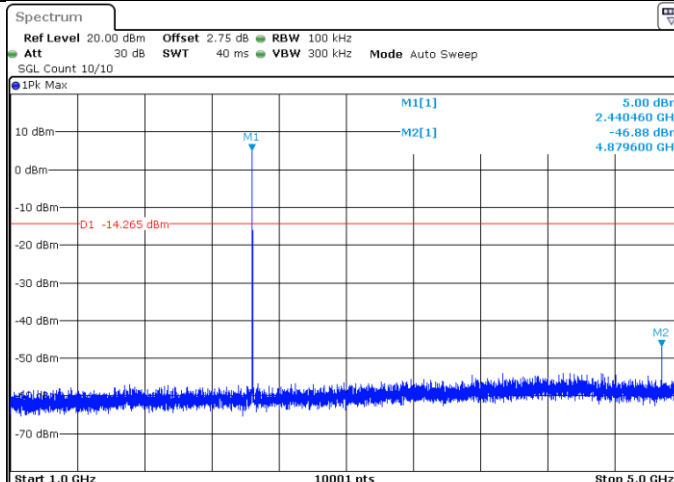

Date: 24.OCT.2022 13:52:14

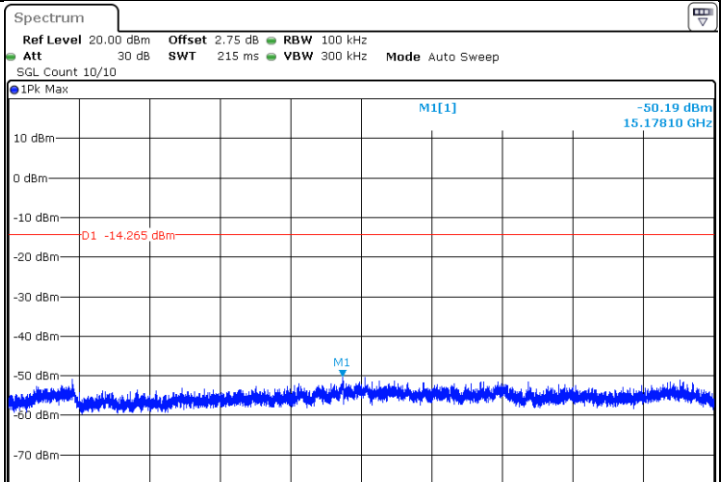

Date: 24.OCT.2022 13:52:23



Out-of-Band Emissions (1Mbps)
Channel 39 (2480MHz)

Reference point

Spurious Emission (30MHz – 1GHz)

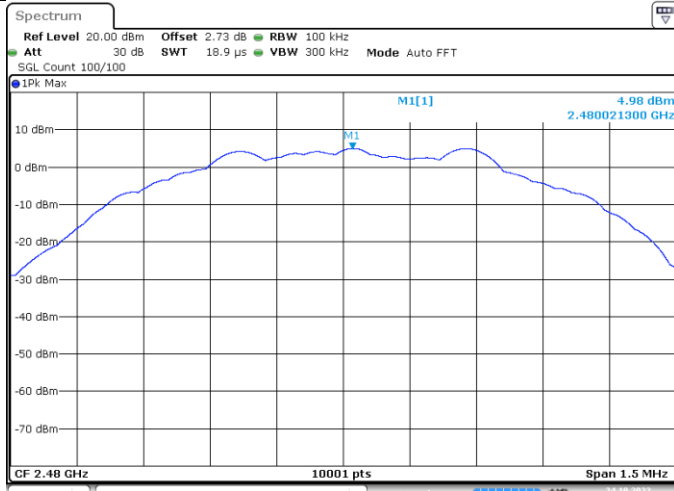

Date: 24.OCT.2022 13:53:42

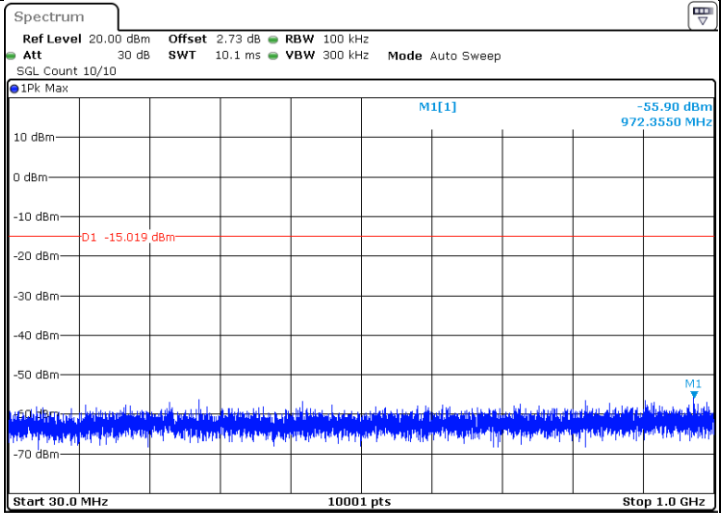

Date: 24.OCT.2022 13:53:43

Spurious Emission (1GHz – 5GHz)

Spurious Emission (5GHz – 26.5GHz)

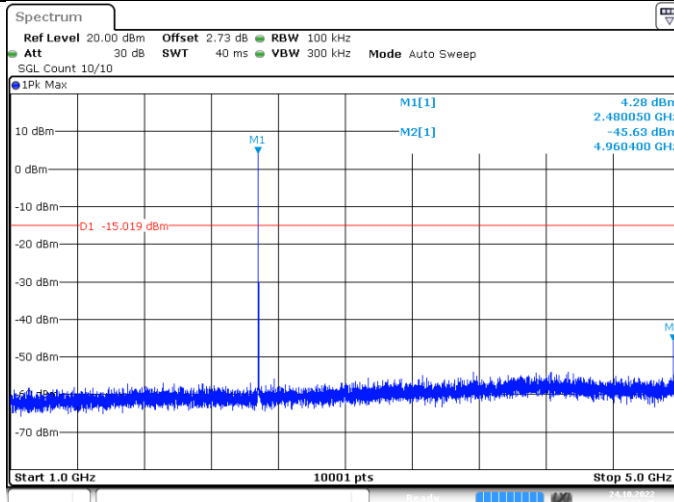

Date: 24.OCT.2022 13:53:46

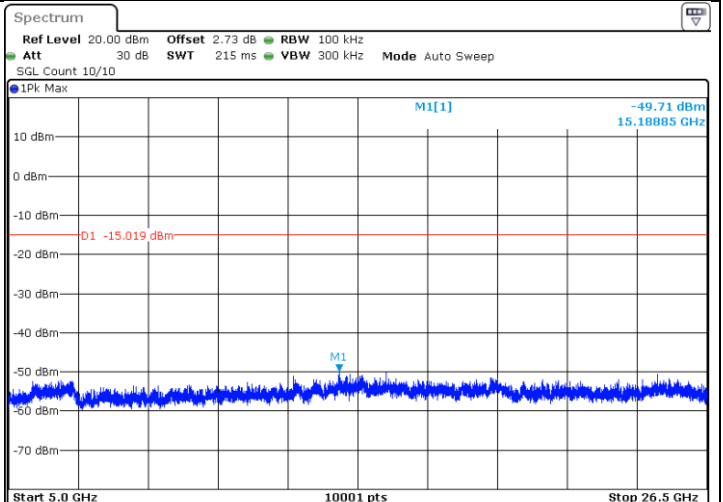

Date: 24.OCT.2022 13:53:54



Out-of-Band Emissions (2Mbps)
Channel 0 (2402MHz)

Reference point

Spurious Emission (30MHz – 1GHz)

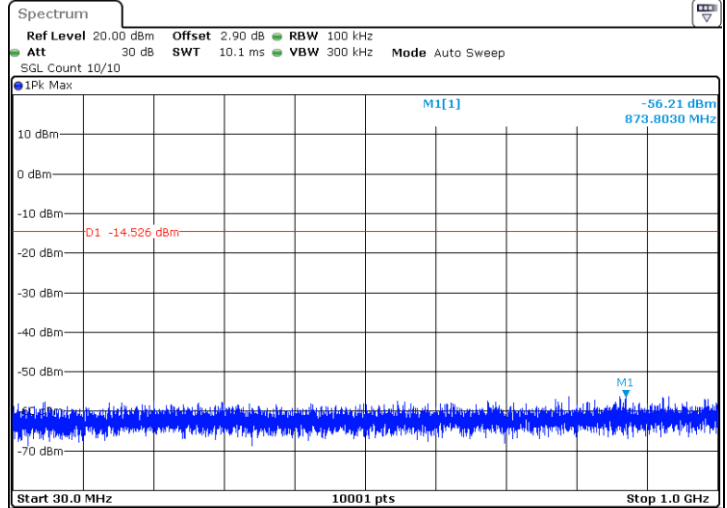
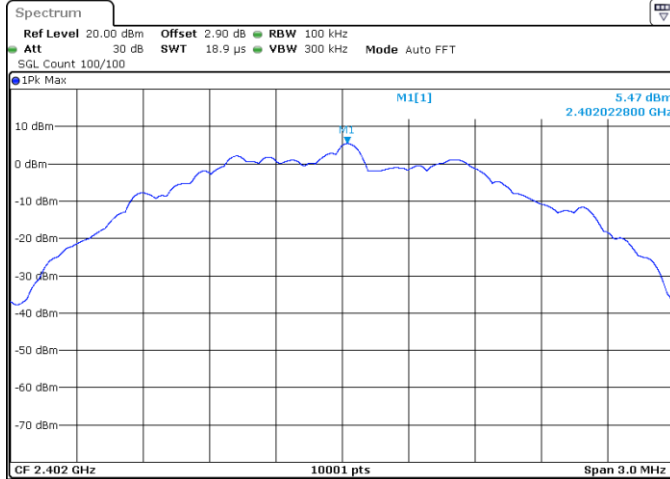

Date: 24 OCT.2022 13:55:23

Date: 24 OCT.2022 13:55:24

Spurious Emission (1GHz – 5GHz)

Spurious Emission (5GHz – 26.5GHz)

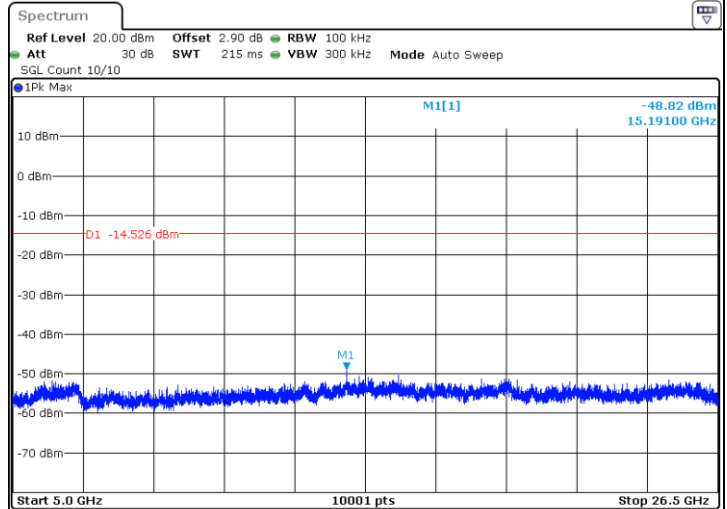
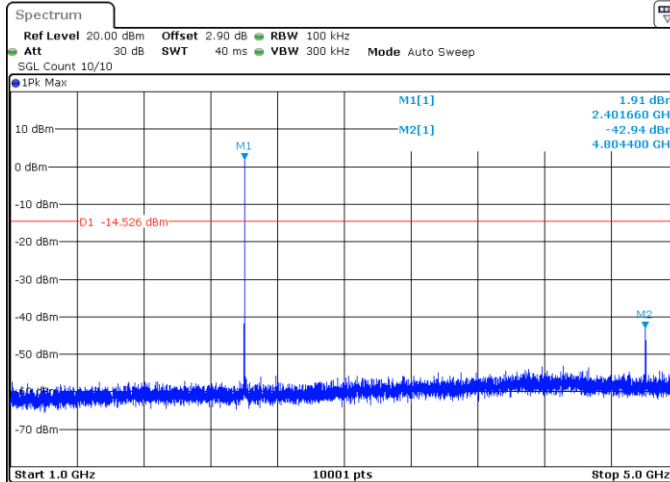

Date: 24 OCT.2022 13:55:27

Date: 24 OCT.2022 13:55:35



Out-of-Band Emissions (2Mbps)
Channel 19 (2440MHz)

Reference point

Spurious Emission (30MHz – 1GHz)

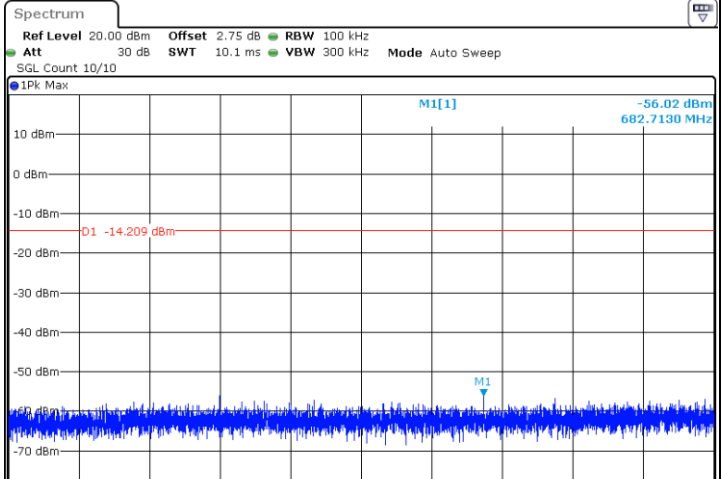
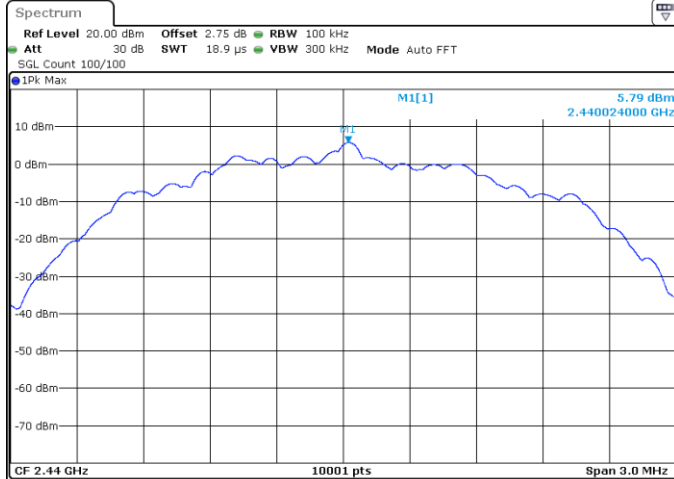

Date: 24.OCT.2022 13:56:35

Date: 24.OCT.2022 13:56:37

Spurious Emission (1GHz – 5GHz)

Spurious Emission (5GHz – 26.5GHz)

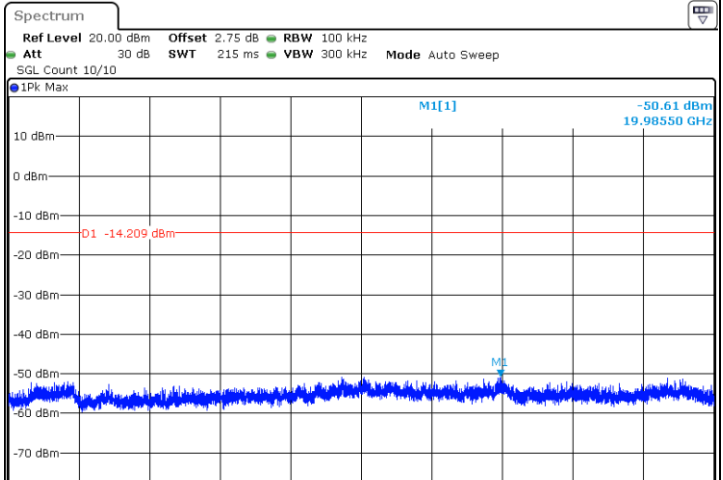
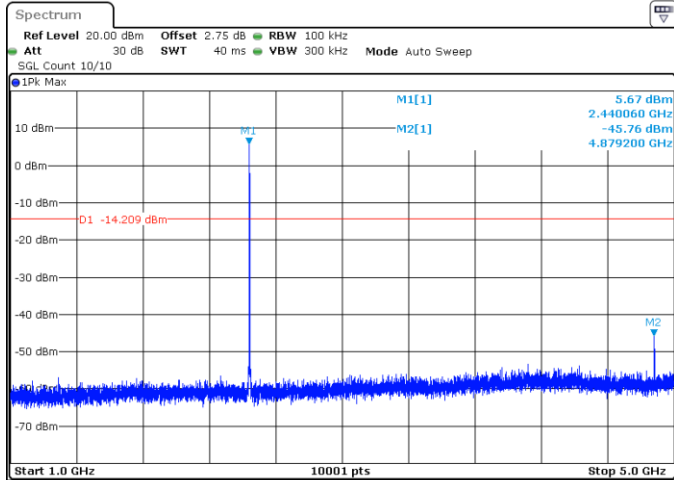

Date: 24.OCT.2022 13:56:39

Date: 24.OCT.2022 13:56:48



Out-of-Band Emissions (2Mbps) Channel 39 (2480MHz)

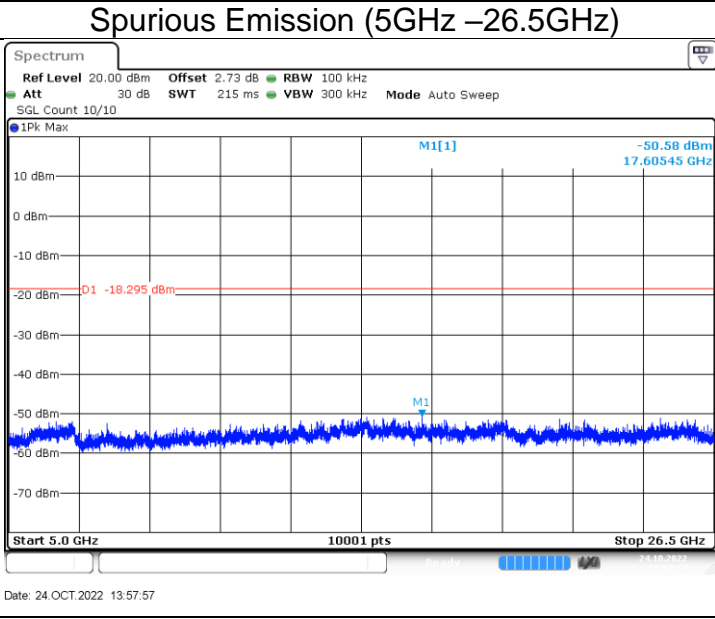
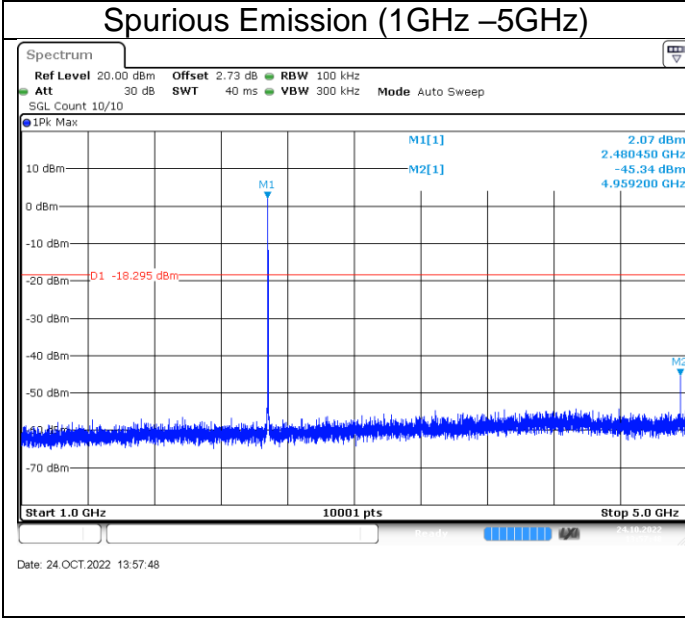
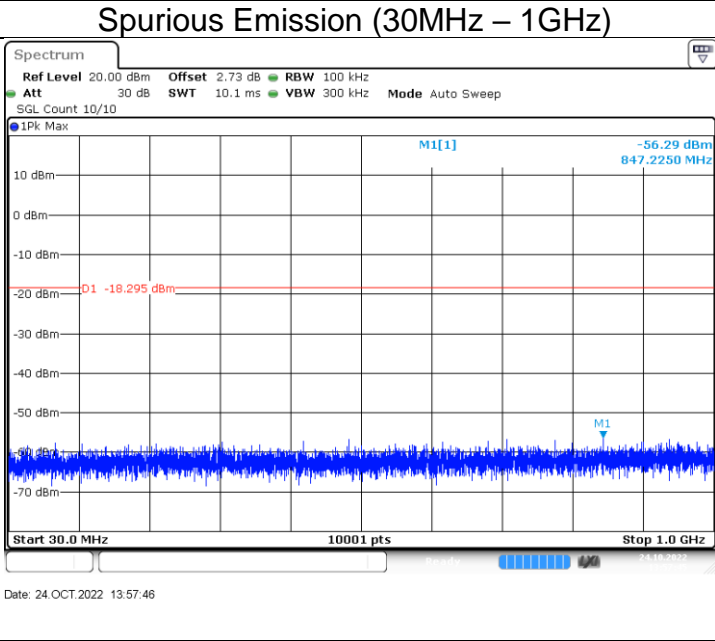
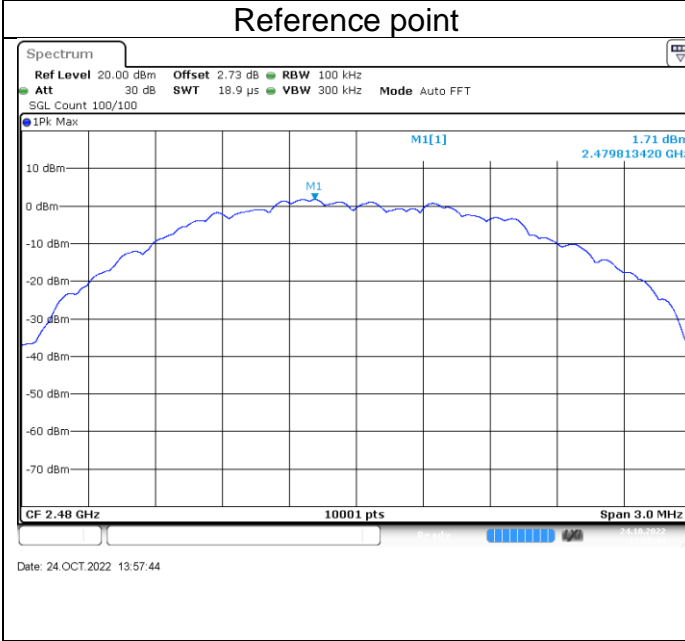



9.6 Band edge

Test Method

- 1 Use the following spectrum analyzer settings:
Span = wide enough to capture the peak level of the in-band emission and all spurious
RBW = 100 kHz, VBW \geq RBW, Sweep = auto, Detector function = peak, Trace = max hold.
- 2 Allow the trace to stabilize, use the peak and delta measurement to record the result.
- 3 The level displayed must comply with the limit specified in this Section.

Limit

According to §15.247(d) and RSS-247 5.5, in any 100 kHz bandwidth outside the frequency bands in which the spread spectrum intentional radiator is operating, the radio frequency power that is produced by the intentional radiator shall be at least 20 dB below that in the 100 kHz bandwidth within the band that contains the highest level of the desired power, based on either an RF conducted or a radiated measurement, provided the transmitter demonstrates compliance with the peak conducted power limits. In addition, radiated emissions which fall in the restricted bands, as defined in §15.205(a) and RSS-Gen 8.10, must also comply with the radiated emission limits specified in 15.209(a) (see Section 15.205(c)) and RSS-Gen.



Test result

1Mbps

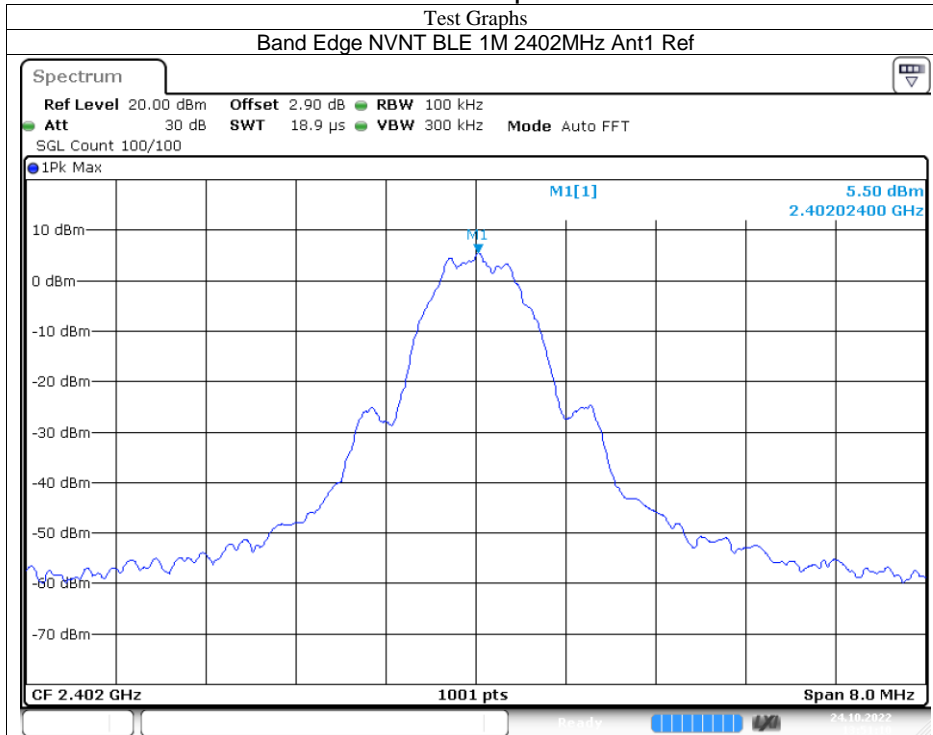

Date: 24.OCT.2022 13:51:10

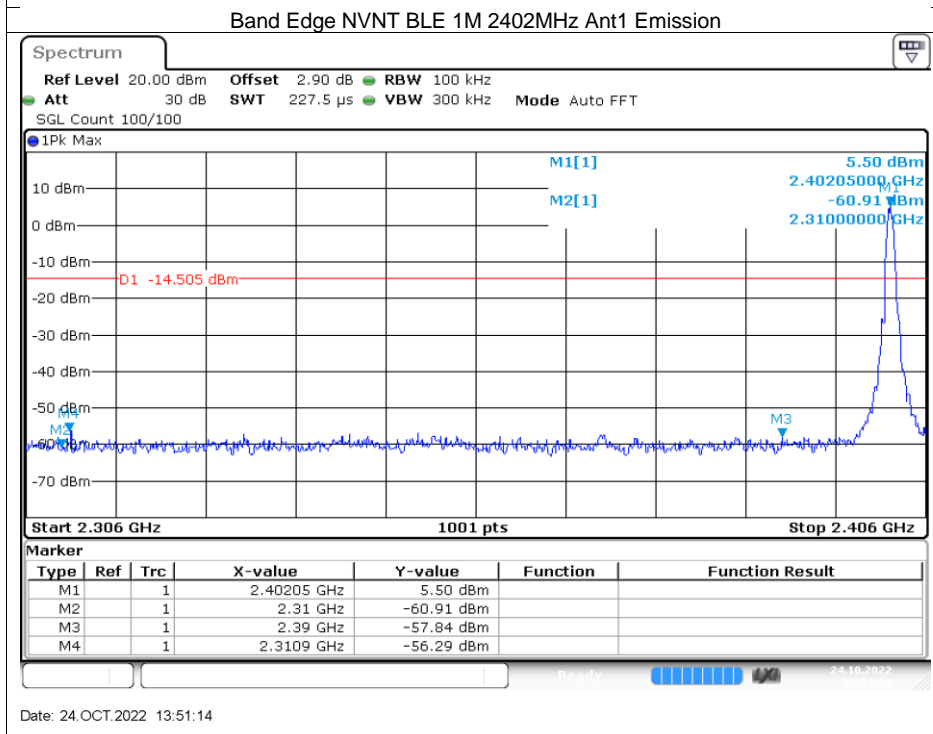

Date: 24.OCT.2022 13:51:14

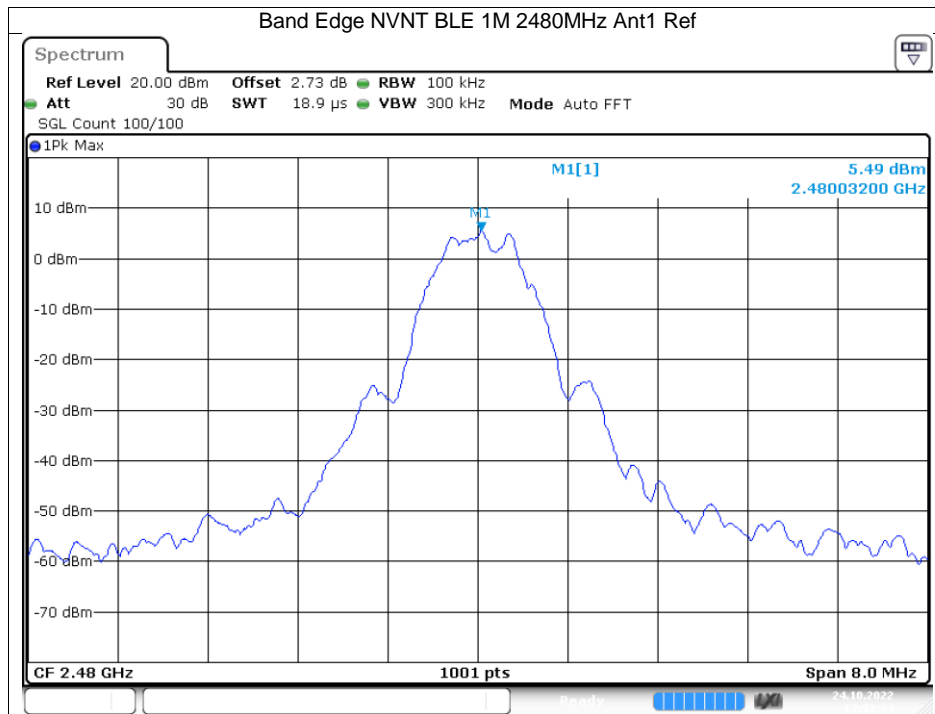

Date: 24.OCT.2022 13:53:34

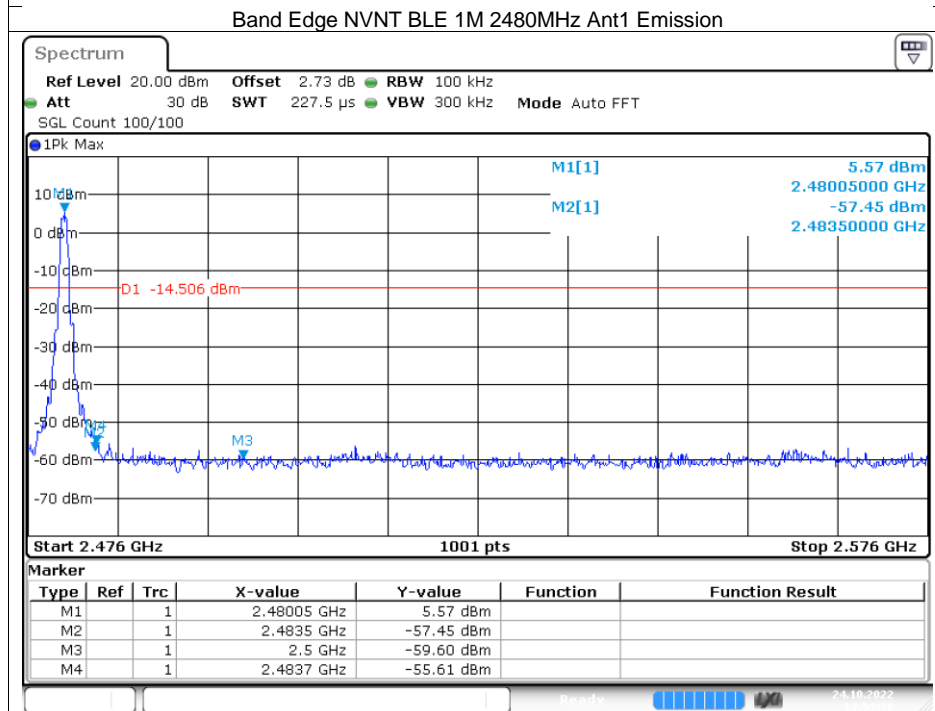

Date: 24.OCT.2022 13:53:38



2Mbps

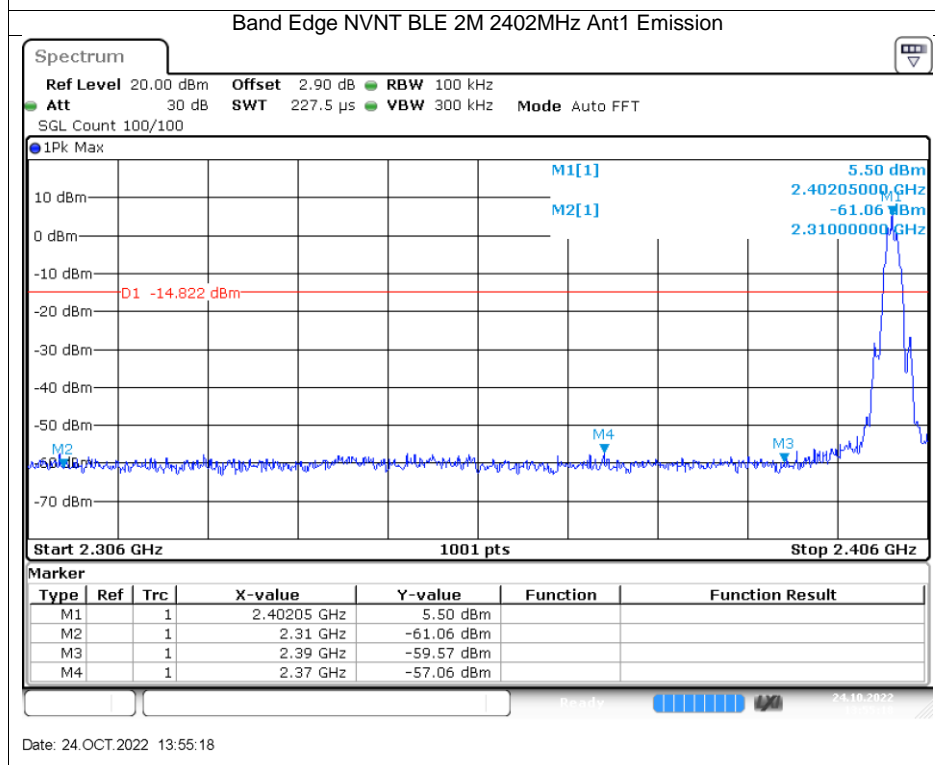
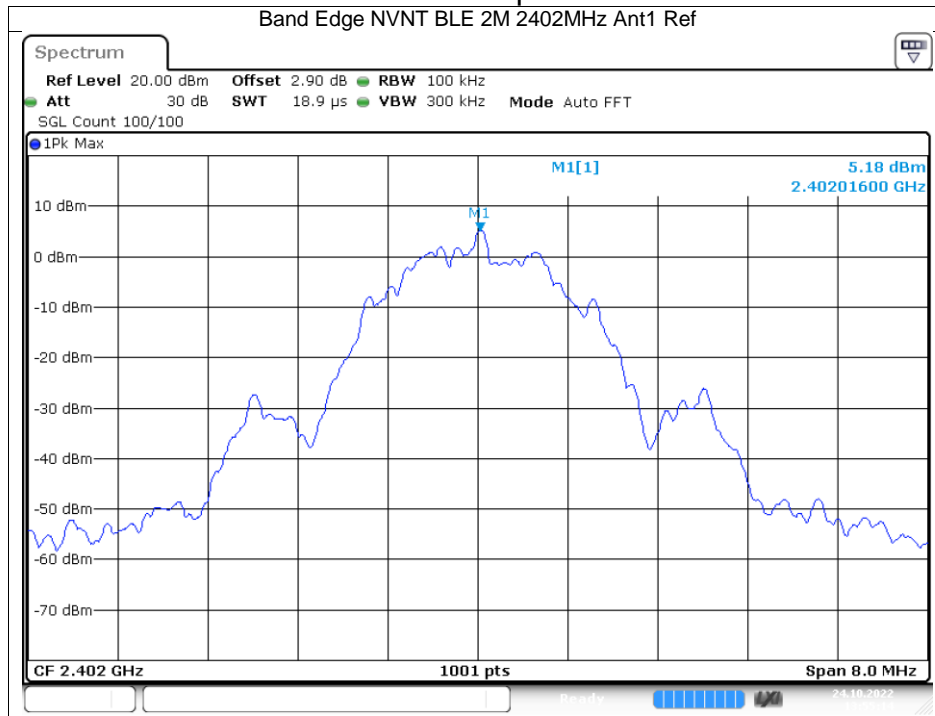

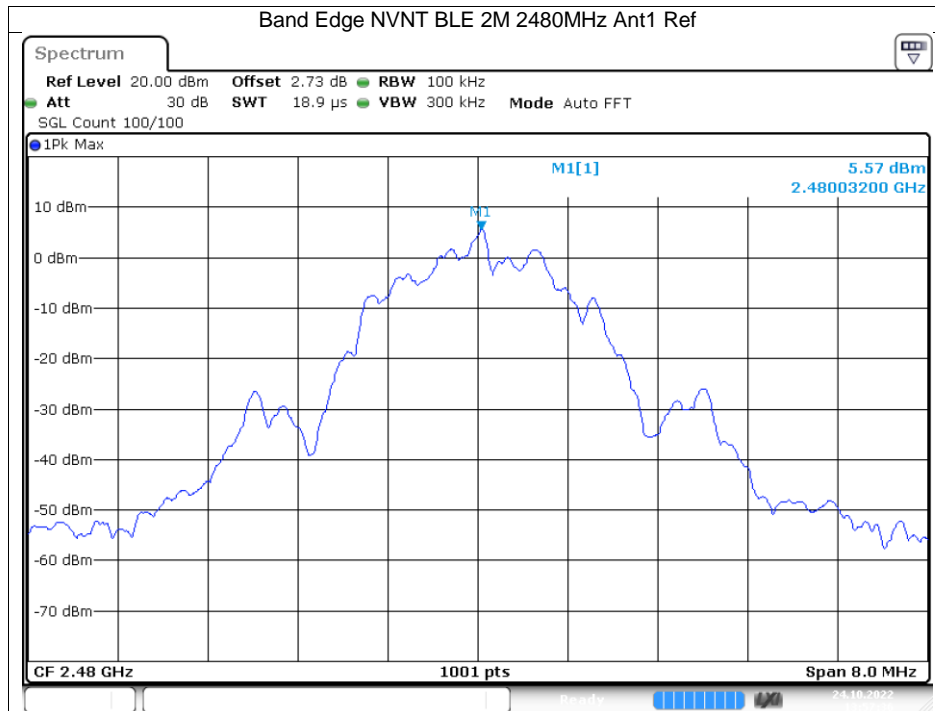

Date: 24.OCT.2022 13:57:36

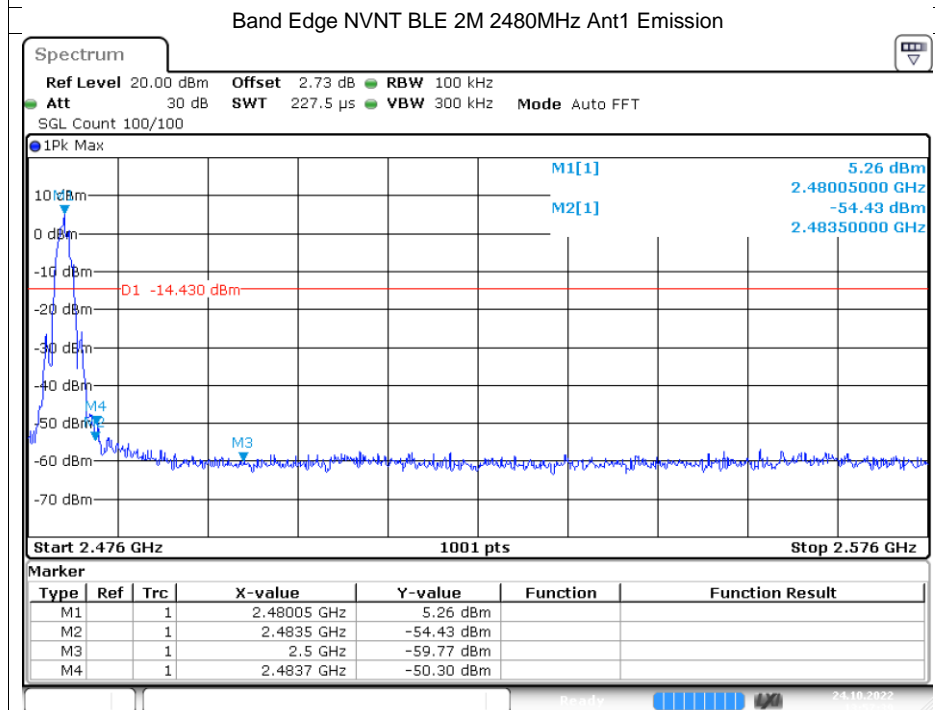

Date: 24.OCT.2022 13:57:40

9.7 Spurious radiated emissions for transmitter

Test Method

1. The EUT was placed on a turn table which is 1.5m above ground plane for above 1GHz and 0.8m above ground for below 1GHz at 3 meter chamber room for test. The table was rotated 360 degrees to determine the position of the highest radiation.
2. The EUT was set 3 meters away from the interference – receiving antenna, which was mounted on the top of a variable – height antenna tower.
3. The height of antenna is varied from one meter to four meters above the ground to determine the maximum value of the field strength. Both horizontal and vertical polarizations of the antenna are set to make the measurement.
4. For each suspected emission, the EUT was arranged to its worst case and then the antenna was tuned to heights from 1 meter to 4 meters and the rotatable table was turned from 0 degrees to 360 degrees to find the maximum reading.
5. Use the following spectrum analyzer settings According to C63.10:

For Below 1GHz

Use the following spectrum analyzer settings:

Span = wide enough to capture the peak level of the in-band emission and all spurious
RBW = 100 kHz to 120 kHz, VBW ≥ RBW for peak measurement, Sweep = auto, Detector function = peak, Trace = max hold.

For Peak unwanted emissions Above 1GHz:

Span = wide enough to capture the peak level of the in-band emission and all spurious
RBW = 1MHz, VBW ≥ RBW for peak measurement, Sweep = auto, Detector function = peak, Trace = max hold.

Procedures for average unwanted emissions measurements above 1000 MHz

- a) RBW = 1MHz.
- b) VBW ≥ [3 × RBW].
- c) Detector = RMS (power averaging), if $[\text{span} / (\# \text{ of points in sweep})] \leq \text{RBW} / 2$. Satisfying this condition can require increasing the number of points in the sweep or reducing the span. If the condition is not satisfied, then the detector mode shall be set to peak.
- d) Averaging type = power (i.e., rms) (As an alternative, the detector and averaging type may be set for linear voltage averaging. Some instruments require linear display mode to use linear voltage averaging. Log or dB averaging shall not be used.)
- e) Sweep time = auto.
- f) Perform a trace average of at least 100 traces if the transmission is continuous. If the transmission is not continuous, then the number of traces shall be increased by a factor of $1 / D$, where D is the duty cycle. For example, with 50% duty cycle, at least 200 traces shall be averaged. (If a specific emission is demonstrated to be continuous—i.e., 100% duty cycle—then rather than turning ON and OFF with the transmit cycle, at least 100 traces shall be averaged.)
- g) If tests are performed with the EUT transmitting at a duty cycle less than 98%, then a correction factor shall be added to the measurement results prior to comparing with the emission limit, to compute the emission level that would have been measured had the test been performed at 100% duty cycle. The correction factor is computed as follows:



- 1) If power averaging (rms) mode was used in the preceding step e), then the correction factor is $[10 \log (1 / D)]$, where D is the duty cycle. For example, if the transmit duty cycle was 50%, then 3 dB shall be added to the measured emission levels.
- 2) If linear voltage averaging mode was used in the preceding step e), then the correction factor is $[20 \log (1 / D)]$, where D is the duty cycle. For example, if the transmit duty cycle was 50%, then 6 dB shall be added to the measured emission levels.
- 3) If a specific emission is demonstrated to be continuous (100% duty cycle) rather than turning ON and OFF with the transmit cycle, then no duty cycle correction is required for that emission.

Limit

The radio emission outside the operating frequency band shall be at least 20 dB below that in the 100 kHz bandwidth within the band that contains the highest level of the desired power. Radiated emissions which fall in the restricted bands, as defined in section 15.205 and RSS-GEN 8.10 must comply with the radiated emission limits specified in section 15.209.

Frequency MHz	Field Strength uV/m	Measured Distance Meters
0.009~0.490	2400/F (kHz)	300
0.490~1.705	24000/F (kHz)	30
1.705~30	30	30

Frequency MHz	Field Strength uV/m	Field Strength dBµV/m	Detector
30-88	100	40	QP
88-216	150	43.5	QP
216-960	200	46	QP
960-1000	500	54	QP
Above 1000	500	54	AV
Above 1000	5000	74	PK

Spurious radiated emissions for transmitter

According to C63.10, if the peak (or quasi-peak) measured value complies with the average limit, it is unnecessary to perform an average measurement, so AV emission value did not show in below table if the peak value complies with average limit. The only worse case test result is listed in the report.

Test result

Test mode:GFSK 1Mbps (2402MHz)					
Frequency MHz	Measure Level (dBuV/m)	Limit (dBuV/M)	Margin (dB)	Detector	Polarization
2369.93	43.75	74.00	30.25	PK	Horiznotal
4804.03	51.86	74.00	22.14	PK	Horiznotal
7206.13	49.65	74.00	24.35	PK	Horiznotal
2386.22	47.41	74.00	26.59	PK	Vertical
4804.00	48.96	74.00	25.04	PK	Vertical
7205.56	49.12	74.00	24.88	PK	Vertical

Test mode:GFSK 1Mbps (2440MHz)					
Frequency MHz	Measure Level (dBuV/m)	Limit (dBuV/M)	Margin (dB)	Detector	Polarization
4880.63	48.65	74.00	25.35	PK	Horiznotal
7320.60	48.76	74.00	25.24	PK	Horiznotal
4880.63	44.42	74.00	29.58	PK	Vertical

Test mode:GFSK 1Mbps (2480MHz)					
Frequency MHz	Measure Level (dBuV/m)	Limit (dBuV/M)	Margin (dB)	Detector	Polarization
2483.60	55.24	74.00	18.76	PK	Horiznotal
2483.60	42.20	54.00	11.80	AV	Horiznotal
4960.43	50.91	74.00	23.09	PK	Horiznotal
7430.33	50.16	74.00	23.84	PK	Horiznotal
2483.60	51.78	74.00	22.22	PK	Vertical
4959.30	43.16	74.00	30.84	PK	Vertical



Test mode:GFSK 2Mbps (2402MHz)					
Frequency MHz	Measure Level (dBuV/m)	Limit (dBuV/M)	Margin (dB)	Detector	Polarization
2388.90	46.35	74.00	27.65	PK	Horiznotal
4806.16	48.77	74.00	25.23	PK	Horiznotal
7204.43	50.31	74.00	23.69	PK	Horiznotal
2370.60	45.77	74.00	28.23	PK	Vertical
4802.90	48.43	74.00	25.57	PK	Vertical

Test mode:GFSK 2Mbps (2440MHz)					
Frequency MHz	Measure Level (dBuV/m)	Limit (dBuV/M)	Margin (dB)	Detector	Polarization
4879.96	52.15	74.00	21.85	PK	Horiznotal
4881.10	44.05	74.00	29.95	PK	Vertical

Test mode:GFSK 2Mbps (2480MHz)					
Frequency MHz	Measure Level (dBuV/m)	Limit (dBuV/M)	Margin (dB)	Detector	Polarization
2483.60	53.28	74.00	20.72	PK	Horiznotal
2483.60	48.10	54.00	5.90	AV	Horiznotal
4961.00	49.12	74.00	24.88	PK	Horiznotal
2483.54	53.19	74.00	20.81	PK	Vertical
2483.54	48.30	54.00	5.70	AV	Vertical
4959.30	42.38	74.00	31.62	PK	Vertical

Remark:

- (1) Emission level= Original Receiver Reading + Correct Factor
- (2) Correct Factor = Antenna Factor + Cable Loss -Amplifier gain
- (3) Margin = limit – Corrected Reading



The worst case of Radiated Emission below 1GHz:

30-1000MHz Radiated Emission

EUT Information

EUT Name: Access control unit
 Model: MPA4MPSU
 Client: Honeywell International Inc
 Op Cond: Power on, TX_2440MHz,2Mbps, AC 110V/60Hz, T21.8, H40.7%, P101.9kPa
 Operator: Cheng Huali
 Test Spec: CRF 47 Part 15.247
 Comment: Horizontal
 Sample No: SHA-681658-1

Sweep Setup: RE_VULB9168_pre_Cont_30-1000 [EMI radiated]

Hardware Setup: RE_VULB9168
 Receiver: [ESR 3]
 Level Unit: dBuV/m

Subrange	Step Size	Detectors	Bandwidth	Sweep Time	Preamp
30 MHz - 1 GHz	48.5 kHz	PK+	120 kHz	0.005 s	20 dB

RE_VULB9168_pre_Cont_30-1000

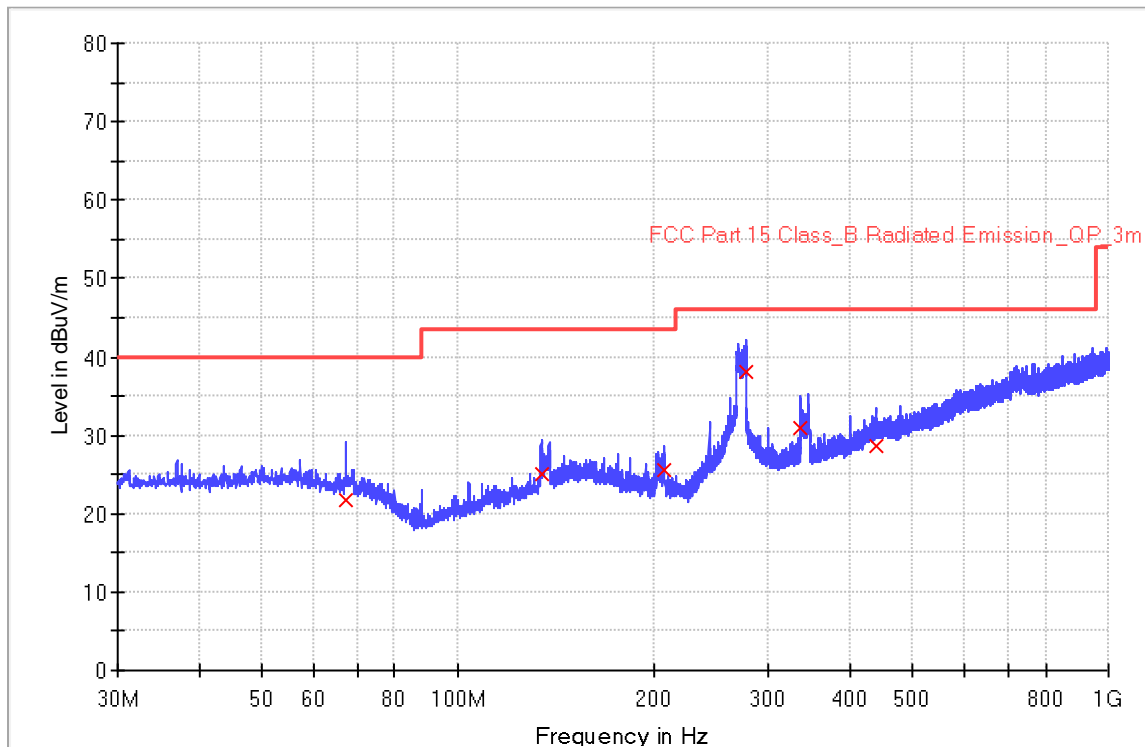



Limit and Margin

Frequency (MHz)	QuasiPeak (dBuV/m)	Meas. Time (ms)	Bandwidth (kHz)	Height (cm)	Pol	Azimuth (deg)	Corr. (dB/m)	Margin - QPK (dB)	Limit - QPK (dBuV/m)
67.200000	21.7	1000.0	120.000	150.0	H	312.0	19.1	18.3	40.0
134.320000	24.9	1000.0	120.000	150.0	H	202.0	19.7	18.6	43.5
207.080000	25.5	1000.0	120.000	150.0	H	242.0	17.6	18.0	43.5
277.040000	38.2	1000.0	120.000	150.0	H	56.0	20.8	7.8	46.0
336.520000	30.9	1000.0	120.000	150.0	H	127.0	22.6	15.1	46.0
438.120000	28.7	1000.0	120.000	150.0	H	358.0	25.6	17.3	46.0



30-1000MHz Radiated Emission

EUT Information

EUT Name: Access control unit
 Model: MPA4MPSU
 Client: Honeywell International Inc
 Op Cond: Power on, TX_2440MHz,2Mbps, AC 110V/60Hz, T21.8, H40.7%, P101.9kPa
 Operator: Cheng Huali
 Test Spec: CRF 47 Part 15.247
 Comment: Vertical
 Sample No: SHA-681658-1

Sweep Setup: RE_VULB9168_pre_Cont_30-1000 [EMI radiated]

Hardware Setup: RE_VULB9168
 Receiver: [ESR 3]
 Level Unit: dBuV/m

Subrange	Step Size	Detectors	Bandwidth	Sweep Time	Preamp
30 MHz - 1 GHz	48.5 kHz	PK+	120 kHz	0.005 s	20 dB

RE_VULB9168_pre_Cont_30-1000

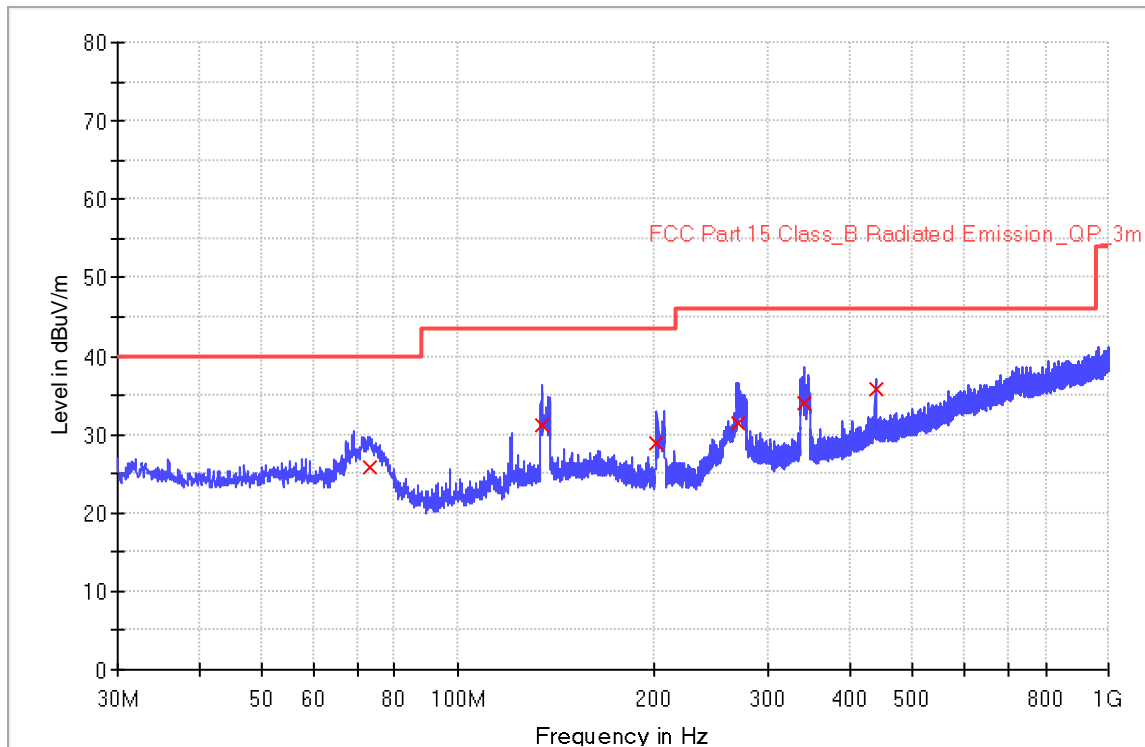



Limit and Margin

Frequency (MHz)	QuasiPeak (dBuV/m)	Meas. Time (ms)	Bandwidth (kHz)	Height (cm)	Pol	Azimuth (deg)	Corr. (dB/m)	Margin - QPK (dB)	Limit - QPK (dBuV/m)
73.200000	25.9	1000.0	120.000	100.0	V	305.0	17.9	14.1	40.0
134.720000	31.3	1000.0	120.000	100.0	V	105.0	19.8	12.2	43.5
202.360000	28.8	1000.0	120.000	100.0	V	282.0	17.6	14.7	43.5
269.000000	31.4	1000.0	120.000	100.0	V	149.0	20.3	14.6	46.0
340.800000	34.1	1000.0	120.000	100.0	V	210.0	22.6	11.9	46.0
438.120000	35.7	1000.0	120.000	100.0	V	48.0	25.6	10.3	46.0

Note 1: Measure Level (dBuV/m) = Reading Level (dBuV) + Factor (dB)

Factor (dB) = Cable Loss (dB) + Antenna Factor (dB/m)

Note 2: The test trace is same as the ambient noise and the amplitude of the emissions are attenuated more than 20dB below the permissible (the test frequency range: 9kHz ~ 30MHz, 18GHz ~ 25GHz), therefore no data appear in the report.



10 Test Equipment List

List of Test Instruments
Test Site1

	DESCRIPTION	MANUFACTURER	MODEL NO.	SERIAL NO.	CAL. DATE	CAL. DUE DATE
C	Signal Analyzer	Rohde & Schwarz	FSV40	101091	2022-8-1	2023-7-31
RE	EMI Test Receiver	Rohde & Schwarz	ESR3	101906	2022-8-1	2023-7-31
	Signal Analyzer	Rohde & Schwarz	FSV40	101091	2022-8-1	2023-7-31
	Trilog Super Broadband Test Antenna	Schwarzbeck	VULB 9168	961	2019-9-23	2024-9-22
	Horn Antenna	Rohde & Schwarz	HF907	102393	2021-3-15	2024-3-14
	Pre-amplifier	Rohde & Schwarz	SCU-18D	19006451	2022-8-1	2023-7-31
	Loop antenna	Rohde & Schwarz	HFH2-Z2	100443	2022-6-13	2023-6-12
	DOUBLE-RIDGED WAVEGUIDE HORN WITH PRE-AMPLIFIER (18 GHZ - 40 GHZ)	ETS-Lindgren	3116C-PA	002222727	2020-9-23	2023-9-22
	3m Semi-anechoic chamber	TDK	9X6X6	----	2021-5-8	2024-5-7
CE	EMI Test Receiver	Rohde & Schwarz	ESR3	101907	2022-8-1	2023-7-31
	LISN	Rohde & Schwarz	ENV216	101924	2022-8-1	2023-7-31

Measurement Software Information			
Test Item	Software	Manufacturer	Version
C	MTS 8310	MWRFtest	2.0.0.0
RE	EMC 32	Rohde & Schwarz	V10.50.40
CE	EMC 32	Rohde & Schwarz	V9.15.03

C - Conducted RF tests

- Conducted peak output power
- 6dB bandwidth and 99% Occupied Bandwidth
- Power spectral density*
- Spurious RF conducted emissions
- Band edge



11 System Measurement Uncertainty

For a 95% confidence level, the measurement expanded uncertainties for defined systems, in accordance with the recommendations of ISO 17025 were:

Items	Extended Uncertainty
Conducted Disturbance at Mains Terminals	150kHz to 30MHz, LISN, 3.16dB
Radiated Disturbance	9kHz to 30MHz, 3.52dB 30MHz to 1GHz, 5.03dB (Horizontal) 5.12dB (Vertical) 1GHz to 18GHz, 5.49dB 18GHz to 40GHz, 5.63dB
RF Conducted Measurement	Power related: 1.16dB Frequency related: 6.00×10^{-8}

Measurement Uncertainty Decision Rule:

Determination of conformity with the specification limits is based on the decision rule according to IEC Guide 115: 2021, clause 4.4.3 and 4.5.1.



12 Photographs of Test Set-ups

Refer to the < Test Setup photos >.

13 Photographs of EUT



Refer to the < External Photos > & < Internal Photos >.

14 Appendix

According to client's declaration,

Model MPA2C3, MPA2C3-4, MPA2MPSU and MPA4MPSU have the same electrical construction (PCB board, electrical schematic) except for the following description (Refer to the table)

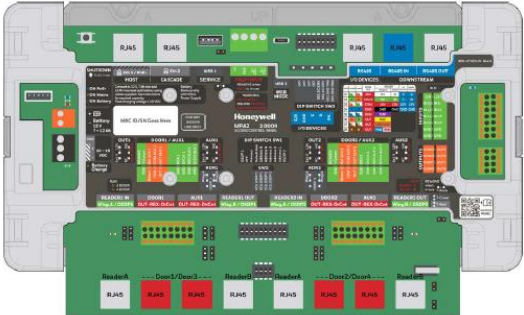
After technical evaluation, we chose model MPA4MPSU to perform all tests.

Model	Power supply	Difference	Photo
MPA2C3	13.8 VDC	MPA2 2 door controller	
MPA2C3-4	13.8 VDC	MPA2 4 door controller	
MPA2MPSU	Input: 100-240V AC Output: 13.8V DC	MPA2, 2 Doors, Controller, Metal Encl NAM	
MPA4MPSU	Input: 100-240V AC Output: 13.8V DC	MPA2, 4 Doors, Controller, Metal Encl NAM	

-----End of Test Report-----