



FCC TEST REPORT

FCC ID: 2A8L4-Z

On Behalf of

Shenzhen Unplug Optoelectronic Technology Co.,LTD

Unplug TV box

Model No.: Project-Z

Prepared for : Shenzhen Unplug Optoelectronic Technology Co.,LTD
Address : 1321, No.5 Golf Avenue, Guanlan street., Longhua District,
Shenzhen, China

Prepared By : Shenzhen Alpha Product Testing Co., Ltd.
Address : Building i, No.2, Lixin Road, Fuyong Street, Bao'an District, 518103,
Shenzhen, Guangdong, China

Report Number : A2305256-C01-R01
Date of Receipt : June 19, 2023
Date of Test : June 19, 2023- July 6, 2023
Date of Report : July 6, 2023
Version Number : V0

TABLE OF CONTENTS

Description	Page
1. Summary of Standards And Results	6
1.1. Description of Standards and Results	6
2. General Information	7
2.1. Description of Device (EUT)	7
2.2. Accessories of Device (EUT)	8
2.3. Tested Supporting System Details	8
2.4. Block Diagram of connection between EUT and simulators	8
2.5. Test Mode Description	8
2.6. Test Conditions	8
2.7. Test Facility	9
2.8. Measurement Uncertainty	9
2.9. Test Equipment List	10
3. Spurious Emission	11
3.1. Test Limits	11
3.2. Test Procedure	13
3.3. Test Setup	14
3.4. Test Results	16
4. Power Line Conducted Emission	27
4.1. Test Limits	27
4.2. Test Procedure	27
4.3. Test Setup	27
4.4. Test Results	27
5. Conducted Maximum Output Power	30
5.1. Test limits	30
5.2. Test Procedure	30
5.3. Test Setup	30
5.4. Test Results	30
6. Peak Power Spectral Density	31
6.1. Test limits	31
6.2. Test Procedure	31
6.3. Test Setup	31
6.4. Test Results	31
7. Bandwidth	35
7.1. Test limits	35
7.2. Test Procedure	35
7.3. Test Setup	35
7.4. Test Results	35
8. Band Edge Check	42
8.1. Test limits	42
8.2. Test Procedure	42
8.3. Test Setup	42
8.4. Test Results	42
9. Frequency stability	47
9.1. Test limit	47
9.2. Test Procedure	47
9.3. Test Setup	47
9.4. Test Results	47
10. Antenna Requirement	48
10.1. Standard Requirement	48
10.2. Antenna Connected Construction	48
10.3. Results	48
11. Test Setup Photo	49
11.1. Photos of Radiated emission	49

11.2. Photos of Conducted Emission test-----	50
12. EUT photo -----	51

TEST REPORT DECLARATION

Applicant : Shenzhen Unplug Optoelectronic Technology Co.,LTD
 Address : 1321, No.5 Golf Avenue, Guanlan street., Longhua District, Shenzhen, China
 Manufacturer : Shenzhen Unplug Optoelectronic Technology Co.,LTD
 Address : 1321, No.5 Golf Avenue, Guanlan street., Longhua District, Shenzhen, China
 EUT Description : Unplug TV box
 (A) Model No. : Project-Z
 (B) Trademark : N/A

Measurement Standard Used:

FCC Rules and Regulations Part 15 Subpart C Section 15.247,

The device described above is tested by Shenzhen Alpha Product Testing Co., Ltd. to determine the maximum emission levels emanating from the device. The maximum emission levels are compared to the FCC Part 15 Subpart C limits both conducted and radiated emissions. The test results are contained in this test report and Shenzhen Alpha Product Testing Co., Ltd. is assumed of full responsibility for the accuracy and completeness of these tests.

After the test, our opinion is that EUT compliance with the requirement of the above standards.

This report applies to above tested sample only. This report shall not be reproduced in parts without written approval of Shenzhen Alpha Product Testing Co., Ltd.

Tested by (name + signature).....: Lucas Pang
 Project Engineer



Approved by (name + signature).....: Reak Yang
 Project Manager

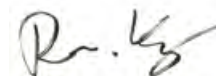

Date of issue.....: July 6, 2023

Revision History

Revision	Issue Date	Revisions	Revised By
V0	July 6, 2023	Initial released Issue	Lucas Pang

1. SUMMARY OF STANDARDS AND RESULTS

1.1. Description of Standards and Results

The EUT have been tested according to the applicable standards as referenced below:

Test Item	Standards Paragraph	Result
Conducted Emission	FCC Part 15: 15.207 RSS-GEN(8.8) ANSI C63.10 :2013	P
6dB Bandwidth	FCC PART 15:15.247(a)(2) RSS-247(5.2 a) ANSI C63.10 :2013	P
Output Power	FCC Part 15: 15.247(b)(3) RSS-247(5.4 d) ANSI C63.10 :2013	P
Radiated Spurious Emission	FCC Part 15: 15.209 FCC Part 15: 15.247(d) RSS-Gen(8.9), RSS-247(5.5) ANSI C63.10 :2013	P
Conducted Spurious & Band Edge Emission	FCC Part 15: 15.247(d) RSS-Gen(8.9), RSS-247(5.5) ANSI C63.10 :2013	P
Power Spectral Density	FCC PART 15:15.247(e) RSS-247(5.2 b) ANSI C63.10 :2013	P
Radiated Band Edge Emission	FCC Part 15: 15.247(d) RSS-GEN(6.13) ANSI C63.10 :2013	P
Frequency stability	RSS-GEN(6.11)	N/A
Antenna Requirement	FCC Part 15: 15.203 RSS-GEN(6.8)	P

Note:

1. P is an abbreviation for Pass.

2. F is an abbreviation for Fail.

3. N/A is an abbreviation for Not Applicable.

4. Decision rules for the conclusion of this test report: decision by actual test data without considering measurement uncertainty.

2. GENERAL INFORMATION

2.1. Description of Device (EUT)

Description/PMN	:	Unplug TV box
Model Number/HVIN(s) Diff.	:	Project-Z N/A
Test Voltage	:	DC 12V from adapter with AC 120V/60Hz
Radio Technology	:	Bluetooth V5.0 LE
Operation frequency	:	2402-2480MHz
Channel No.	:	40 channels
Data rate	:	1Mbps/2Mbps
Channel Separation	:	2MHz
Modulation	:	GFSK
Antenna Type	:	Internal Antenna, Maximum Gain is 2.48dBi (Antenna information is provided by applicant.)
Software Version	:	V1.0
Hardware version/FVIN	:	V1.0

2.2. Accessories of Device (EUT)

Accessories	:	AC/DC ADAPTER
Manufacturer	:	Shenzhen Junchen Technology Co., Ltd.
Model	:	J302-1203000UX
Ratings	:	INPUT:100-240V~50/60Hz 1.5A OUTPUT: 12.0V=3.0A 36.0W

2.3. Tested Supporting System Details

No.	Description	Manufacturer	Model	Serial Number	Certification or SDOC
1.	Notebook	Thinkpad	E14	N/A	N/A

2.4. Block Diagram of connection between EUT and simulators

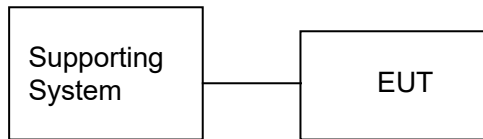

2.5. Test Mode Description

Tested mode, channel, and data rate information		
Mode	Channel	Frequency (MHz)
GFSK(1Mbps/2Mbps)	Low : CH0	2402
	Middle: CH19	2440
	High: CH39	2480

The test software was used to control EUT work in Continuous TX mode, and select test channel, wireless mode.

2.6. Test Conditions

Items	Required	Actual
Temperature range:	15-35°C	27°C
Humidity range:	25-75%	56%
Pressure range:	86-106kPa	98kPa

2.7. Test Facility

Shenzhen Alpha Product Testing Co., Ltd
 Building i, No.2, Lixin Road, Fuyong Street, Bao'an District, 518103,
 Shenzhen, Guangdong, China

June 21, 2018 File on Federal Communication Commission
 Registration Number: 293961
 Designation Number: CN1236

July 15, 2019 Certificated by IC
 Registration Number: CN0085

2.8. Measurement Uncertainty

(95% confidence levels, k=2)

Item	Uncertainty
Uncertainty for Power point Conducted Emissions Test	1.63dB
Uncertainty for Radiation Emission test in 3m chamber (below 30MHz)	3.5dB
Uncertainty for Radiation Emission test in 3m chamber (30MHz to 1GHz)	3.74dB(Polarize: V)
	3.76dB(Polarize: H)
Uncertainty for Radiation Emission test in 3m chamber (1GHz to 25GHz)	3.77dB(Polarize: V)
	3.80dB(Polarize: H)
Uncertainty for radio frequency	5.06×10^{-8} GHz
Uncertainty for conducted RF Power	0.40dB
Uncertainty for temperature	0.2°C
Uncertainty for humidity	1%
Uncertainty for DC and low frequency voltages	0.06%

2.9. Test Equipment List

Equipment	Manufacture	Model No.	Firmware version	Serial No.	Last cal.	Cal Interval
9*6*6 anechoic chamber	CHENYU	9*6*6	/	N/A	2022.05.17	3Year
Spectrum analyzer	ROHDE&SCHWARZ	FSV40-N	2.3	102137	2022.08.22	1Year
Spectrum analyzer	Agilent	N9020A	A.14.16	MY499100060	2022.08.22	1Year
Receiver	ROHDE&SCHWARZ	ESR	2.28 SP1	1316.3003K03-10 2082-Wa	2022.08.22	1Year
Receiver	R&S	ESCI	4.42 SP1	101165	2022.08.22	1Year
Bilog Antenna	Schwarzbeck	VULB 9168	/	VULB 9168#627	2021.08.30	2Year
Horn Antenna	SCHWARZBECK	BBHA 9120 D	/	2106	2021.08.30	2Year
Active Loop Antenna	SCHWARZBECK	FMZB 1519B	/	00059	2021.08.30	2Year
RF Cable	Resenberger	Cable 1	/	RE1	2022.08.22	1Year
RF Cable	Resenberger	Cable 2	/	RE2	2022.08.22	1Year
RF Cable	Resenberger	Cable 3	/	CE1	2022.08.22	1Year
Pre-amplifier	HP	HP8347A	/	2834A00455	2022.08.22	1Year
Pre-amplifier	Agilent	8449B	/	3008A02664	2022.08.22	1Year
L.I.S.N.#1	Schwarzbeck	NSLK8126	/	8126-466	2022.08.22	1Year
L.I.S.N.#2	ROHDE&SCHWARZ	ENV216	/	101043	2022.08.23	1 Year
Horn Antenna	SCHWARZBECK	BBHA9170	/	00946	2021.08.30	2 Year
Preamplifier	SKET	LNPA_1840 -50	/	SK2018101801	2022.08.22	1 Year
Power Meter	Agilent	E9300A	/	MY41496628	2022.08.22	1 Year
Power Sensor	DARE	RPR3006W	/	15100041SNO91	2022.08.22	1 Year
Temp. & Humid. Chamber	Weihuang	WHTH-1000 -40-880	/	100631	2022.08.22	1 Year
Switching Mode Power Supply	JUNKE	JK12010S	/	20140927-6	2022.08.22	1 Year
Adjustable attenuator	MWRFtest	N/A	/	N/A	N/A	N/A
10dB Attenuator	Mini-Circuits	DC-6G	/	N/A	N/A	N/A

Software Information			
Test Item	Software Name	Manufacturer	Version
RE	EZ-EMC	Farad	Alpha-3A1
CE	EZ-EMC	Farad	Alpha-3A1
RF-CE	MTS 8310	MW	V2.0.0.0

3. SPURIOUS EMISSION

3.1. Test Limits

All the emissions appearing within 15.205 restricted frequency bands shall not exceed the limits shown in 15.209, all the other emissions shall be at least 20dB below the fundamental emissions, or comply with 15.209 limits.

15.205 Restricted frequency band

MHz	MHz	MHz	GHz
0.090 - 0.110	16.42 - 16.423	399.9 - 410	4.5 - 5.15
¹ 0.495 - 0.505	16.69475 - 16.69525	608 - 614	5.35 - 5.46
2.1735 - 2.1905	16.80425 - 16.80475	960 - 1240	7.25 - 7.75
4.125 - 4.128	25.5 - 25.67	1300 - 1427	8.025 - 8.5
4.17725 - 4.17775	37.5 - 38.25	1435 - 1626.5	9.0 - 9.2
4.20725 - 4.20775	73 - 74.6	1645.5 - 1646.5	9.3 - 9.5
6.215 - 6.218	74.8 - 75.2	1660 - 1710	10.6 - 12.7
6.26775 - 6.26825	108 - 121.94	1718.8 - 1722.2	13.25 - 13.4
6.31175 - 6.31225	123 - 138	2200 - 2300	14.47 - 14.5
8.291 - 8.294	149.9 - 150.05	2310 - 2390	15.35 - 16.2
8.362 - 8.366	156.52475 - 156.52525	2483.5 - 2500	17.7 - 21.4
8.37625 - 8.38675	156.7 - 156.9	2690 - 2900	22.01 - 23.12
8.41425 - 8.41475	162.0125 - 167.17	3260 - 3267	23.6 - 24.0
12.29 - 12.293	167.72 - 173.2	3332 - 3339	31.2 - 31.8
12.51975 - 12.52025	240 - 285	3345.8 - 3358	36.43 - 36.5
12.57675 - 12.57725	322 - 335.4	3600 - 4400	(²)

RSS-GEN Restricted frequency band

Table 7 – Restricted frequency bands ^{Note 1}

MHz	MHz	GHz
0.090 - 0.110	149.9 - 150.05	9.0 - 9.2
0.495 - 0.505	156.52475 - 156.52525	9.3 - 9.5
2.1735 - 2.1905	156.7 - 156.9	10.6 - 12.7
3.020 - 3.026	162.0125 - 167.17	13.25 - 13.4
4.125 - 4.128	167.72 - 173.2	14.47 - 14.5
4.17725 - 4.17775	240 – 285	15.35 - 16.2
4.20725 - 4.20775	322 - 335.4	17.7 - 21.4
5.677 - 5.683	399.9 - 410	22.01 - 23.12
6.215 - 6.218	608 - 614	23.6 - 24.0

6.26775 - 6.26825	960 - 1427	31.2 - 31.8
6.31175 - 6.31225	1435 - 1626.5	36.43 - 36.5
8.291 - 8.294	1645.5 - 1646.5	Above 38.6
8.362 - 8.366	1660 - 1710	
8.37625 - 8.38675	1718.8 - 1722.2	
8.41425 - 8.41475	2200 - 2300	
12.29 - 12.293	2310 - 2390	
12.51975 - 12.52025	2483.5 - 2500	
12.57675 - 12.57725	2655 - 2900	
13.36 - 13.41	3260 – 3267	
16.42 - 16.423	3332 - 3339	
16.69475 - 16.69525	3345.8 - 3358	
16.80425 - 16.80475	3500 - 4400	
25.5 - 25.67	4500 - 5150	
37.5 - 38.25	5350 - 5460	
73 - 74.6	7250 - 7750	
74.8 - 75.2	8025 – 8500	
108 – 138		

Note 1: Certain frequency bands listed in table 7 and in bands above 38.6 GHz are designated for licence-exempt applications. These frequency bands and the requirements that apply to related devices are set out in the 200 and 300 series of RSSs.

15.209 Limit

FREQUENCY MHz	DISTANCE Meters	FIELD STRENGTHS LIMIT	
		$\mu\text{V}/\text{m}$	$\text{dB}(\mu\text{V})/\text{m}$
0.009-0.490	300	2400/F(KHz)	/
0.490-1.705	30	24000/F(KHz)	/
1.705-30	30	30	29.5
30 ~ 88	3	100	40.0
88 ~ 216	3	150	43.5
216 ~ 960	3	200	46.0
960 ~ 1000	3	500	54.0
Above 1000	3	74.0 dB(μV)/m (Peak) 54.0 dB(μV)/m (Average)	
Note 1: The peak limit is 20 dB higher than the average limit			
Note 2: Peak limit applies (AVG limit + 20 dB) as well as RSS-247 Section 5.5			

Harmonic emissions limits comply with below 54 dB $\mu\text{V}/\text{m}$ at 3m. Other emissions radiated outside of the specified frequency bands, except for harmonics, shall be attenuated by at least 50 dB below the level of the fundamental or comply with the radiated emissions limits specified in section 15.209(a) limit in the table below has to be followed.

Table 5 – General field strength limits at frequencies above 30 MHz

Frequency (MHz)	Field strength ($\mu\text{V}/\text{m}$ at 3 m)
30 – 88	100
88 – 216	150
216 – 960	200
Above 960	500

Table 6 – General field strength limits at frequencies below 30 MHz

Frequency	Magnetic field strength (H-Field) ($\mu\text{A}/\text{m}$)	Measurement distance (m)
9 - 490 kHz ^{Note 1}	6.37/F (F in kHz)	300
490 - 1705 kHz	63.7/F (F in kHz)	30
1.705 - 30 MHz	0.08	30

Note 1: The emission limits for the ranges 9-90 kHz and 110-490 kHz are based on measurements employing a linear average detector.

3.2. Test Procedure

The measuring distance of 3m shall be used for measurements at frequency up to 1GHz and above 1GHz. The EUT was placed on a rotating 0.8 m high above ground for below 1GHz and 1.5m high for above 1GHz testing, The table was rotated 360 degrees to determine the position of the highest radiation.

The Test antenna shall vary between 1m and 4m, Both Horizontal and Vertical antenna are set of make

measurement.

The initial step in collecting radiated emission data is a spectrum analyzer Peak detector mode pre-scanning the measurement frequency range. Significant Peaks are then marked, and then Quasi Peak Detector mode premeasured.

If Peak value comply with QP limit Below 1GHz, the EUT deemed to comply with QP limit. But the Peak value and average value both need to comply with applicable limit above 1GHz.

For the actual test configuration, please see the test setup photo.

3.3. Test Setup

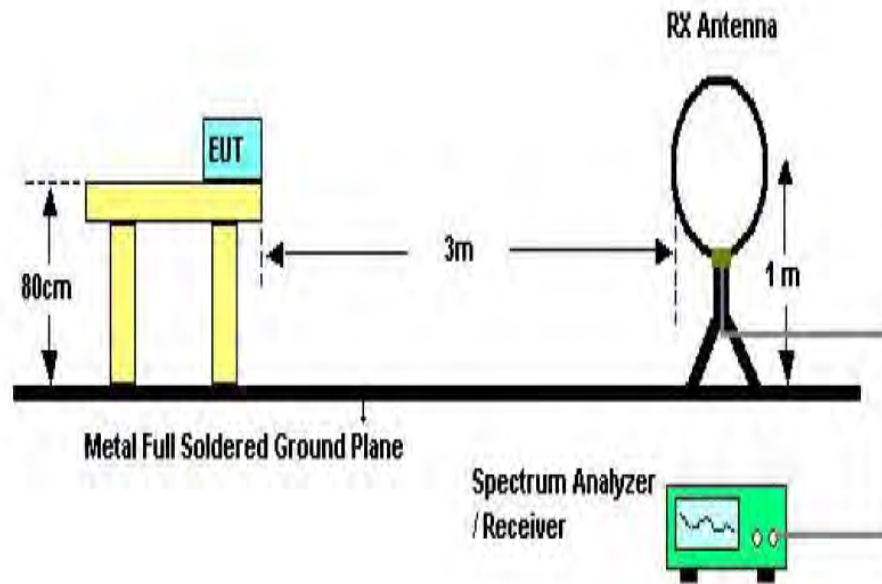

Below 30MHz Test Setup

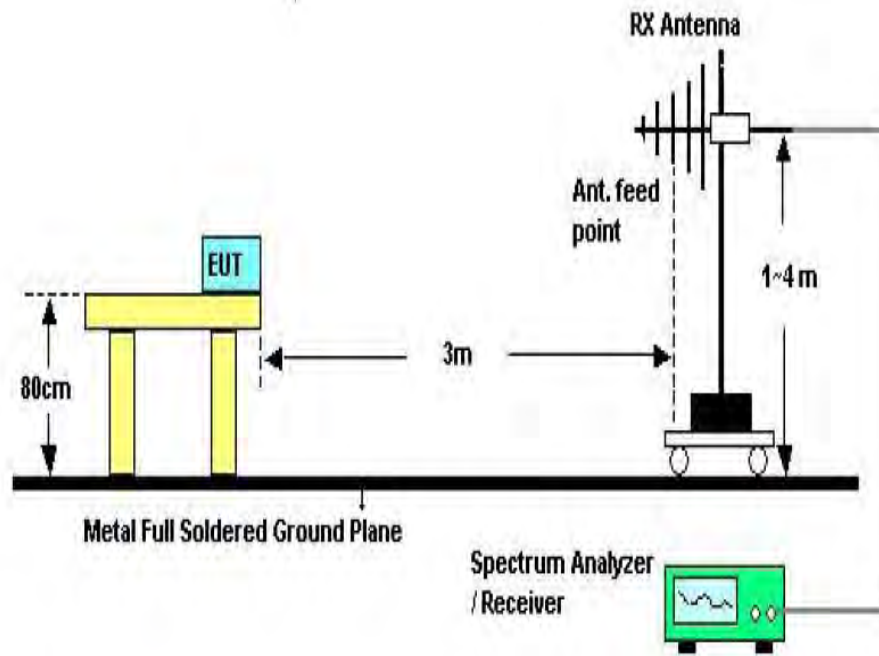

Above 30MHz Test Setup

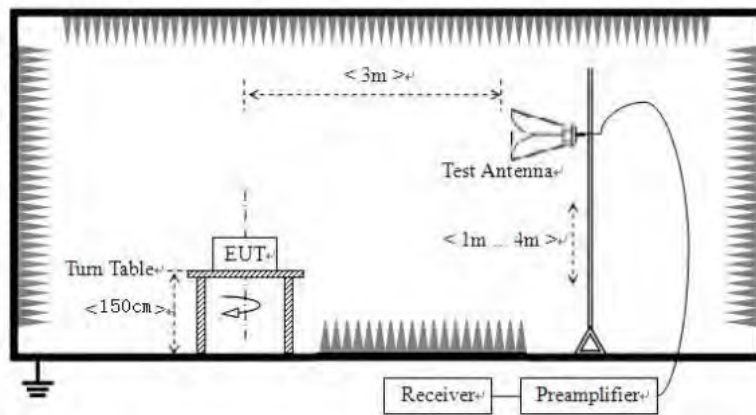

Above 1GHz Test Setup

3.4. Test Results

Test Condition

Continual Transmitting in maximum power.

9KHz~150KHz	RBW200Hz	VBW1KHz
150KHz~30MHz	RBW9KHz	VBW 30KHz
30MHz~1GHz	RBW120KHz	VBW 300KHz
Above1GHz	RBW1MHz	VBW 3MHz

We have scanned from 9 kHz to the 10th harmonic of the EUT.

Detailed information please see the following page.

From 9KHz to 30MHz: Conclusion: Pass

Note: 1.The amplitude of spurious emissions which are attenuated by more than 20dB below the permissible value has no need to be reported.

2.Only show the test data of the worst Channel in this report.

From 30MHz to 1000MHz: Conclusion: Pass

Vertical:

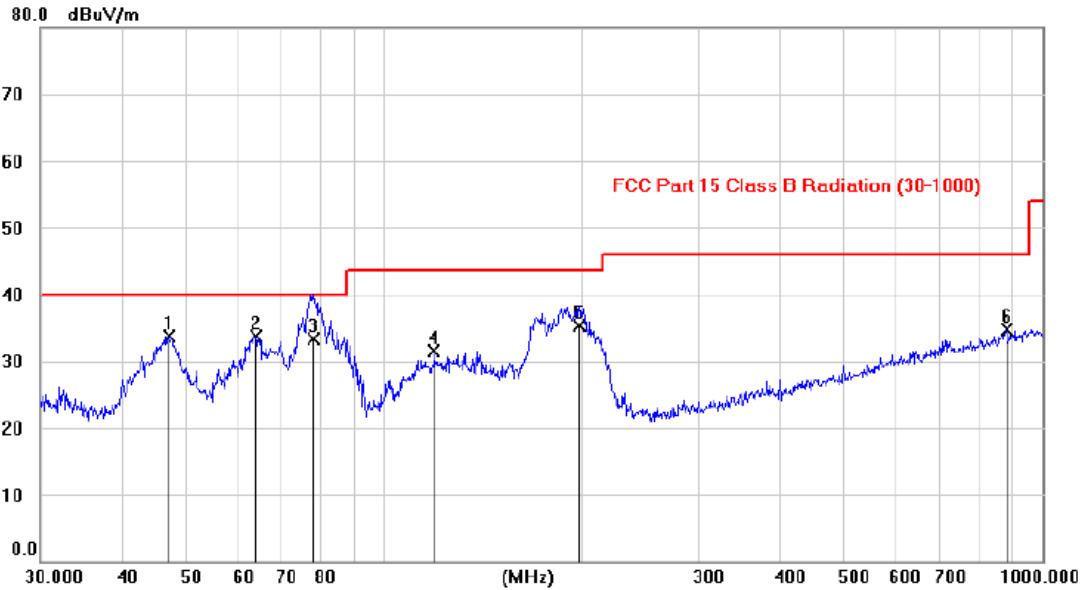

No.	Mk.	Freq.	Reading Level	Correct Factor	Measurement	Limit	Margin	Antenna Height	Table Degree	
		MHz	dBuV	dB	dBuV/m	dBuV/m	dB	cm	degree	Comment
1	*	47.1709	19.72	14.07	33.79	40.00	-6.21			peak
2		63.8408	21.21	12.52	33.73	40.00	-6.27			peak
3		77.8745	23.09	10.20	33.29	40.00	-6.71	100	0	QP
4		119.2408	18.65	12.95	31.60	43.50	-11.90			peak
5		198.3096	24.32	11.00	35.32	43.50	-8.18	100	0	QP
6		883.3664	10.81	23.82	34.63	46.00	-11.37			peak

Note: 1. *:Maximum data; x:Over limit; !:over margin.

2. Measurement=Reading Level+Correct Factor; Correct Factor=Antenna Factor+Cable Loss.

Horizontal:

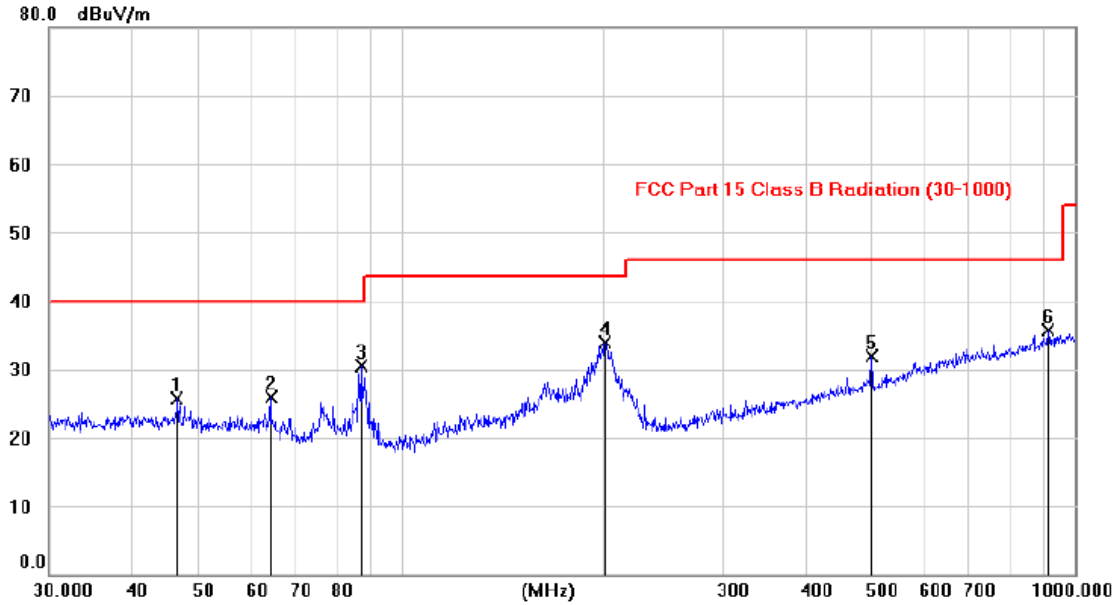

No.	Mk.	Freq.	Reading Level	Correct Factor	Measurement	Limit	Margin	Antenna Height	Table Degree	
		MHz	dBuV	dB	dBuV/m	dBuV/m	dB	cm	degree	Comment
1		46.6227	11.59	14.09	25.68	40.00	-14.32			peak
2		64.0726	13.38	12.49	25.87	40.00	-14.13			peak
3	*	87.3462	20.59	10.01	30.60	40.00	-9.40			peak
4		200.8054	22.90	10.91	33.81	43.50	-9.69			peak
5		500.0088	13.71	18.21	31.92	46.00	-14.08			peak
6		913.5025	11.53	24.22	35.75	46.00	-10.25			peak

Note: 1. *: Maximum data; x: Over limit; !: over margin.

2. Measurement=Reading Level+Correct Factor; Correct Factor=Antenna Factor+Cable Loss.

Notes: Above is below 1GHz test data. This report only shall the worst case mode for TX 2440MHz.(1Mbps)

From 1G-25GHz(1Mbps):

Test Mode: TX Low									
Freq (MHz)	Read Level (dBuV/m)	Polar (H/V)	Antenna Factor (dB/m)	Cable loss(dB)	Amp Factor (dB)	Result (dBuV/m)	Limit (dBuV/m)	Margin (dB)	Remark
4804	48.54	V	33.93	10.18	34.26	58.39	74	-15.61	PK
4804	36.78	V	33.93	10.18	34.26	46.63	54	-7.37	AV
7206	/	/	/	/	/	/	/	/	/
9608	/	/	/	/	/	/	/	/	/
4804	47.89	H	33.93	10.18	34.26	57.74	74	-16.26	PK
4804	35.85	H	33.93	10.18	34.26	45.70	54	-8.30	AV
7206	/	/	/	/	/	/	/	/	/
9608	/	/	/	/	/	/	/	/	/
Test Mode: TX Mid									
4880	49.88	V	33.95	10.20	34.26	59.77	74	-14.23	PK
4880	35.05	V	33.95	10.20	34.26	44.94	54	-9.06	AV
7320	/	/	/	/	/	/	/	/	/
9760	/	/	/	/	/	/	/	/	/
4880	48.65	H	33.95	10.20	34.26	58.54	74	-15.46	PK
4880	34.24	H	33.95	10.20	34.26	44.13	54	-9.87	AV
7320	/	/	/	/	/	/	/	/	/
9760	/	/	/	/	/	/	/	/	/
Test Mode: TX High									
4960	47.23	V	33.98	10.22	34.25	57.18	74	-16.82	PK
4960	33.49	V	33.98	10.22	34.25	43.44	54	-10.56	AV
7440	/	/	/	/	/	/	/	/	/
9920	/	/	/	/	/	/	/	/	/
4960	46.87	H	33.98	10.22	34.25	56.82	74	-17.18	PK
4960	32.81	H	33.98	10.22	34.25	42.76	54	-11.24	AV
7440	/	/	/	/	/	/	/	/	/
9920	/	/	/	/	/	/	/	/	/

Note:
1, Result = Read level + Antenna factor + cable loss-Amp factor
2, All the other emissions not reported were too low to read and deemed to comply with FCC limit.

From 1G-25GHz(2Mbps):

Test Mode: TX Low									
Freq (MHz)	Read Level (dBUV/m)	Polar (H/V)	Antenna Factor (dB/m)	Cable loss(dB)	Amp Factor (dB)	Result (dBUV/m)	Limit (dBUV/m)	Margin (dB)	Remark
4804	48.34	V	33.93	10.18	34.26	58.19	74	-15.81	PK
4804	36.65	V	33.93	10.18	34.26	46.50	54	-7.50	AV
7206	/	/	/	/	/	/	/	/	/
9608	/	/	/	/	/	/	/	/	/
4804	47.95	H	33.93	10.18	34.26	57.80	74	-16.20	PK
4804	35.35	H	33.93	10.18	34.26	45.20	54	-8.80	AV
7206	/	/	/	/	/	/	/	/	/
9608	/	/	/	/	/	/	/	/	/
Test Mode: TX Mid									
4880	49.10	V	33.95	10.20	34.26	58.99	74	-15.01	PK
4880	35.80	V	33.95	10.20	34.26	45.69	54	-8.31	AV
7320	/	/	/	/	/	/	/	/	/
9760	/	/	/	/	/	/	/	/	/
4880	48.45	H	33.95	10.20	34.26	58.34	74	-15.66	PK
4880	34.41	H	33.95	10.20	34.26	44.30	54	-9.70	AV
7320	/	/	/	/	/	/	/	/	/
9760	/	/	/	/	/	/	/	/	/
Test Mode: TX High									
4960	47.87	V	33.98	10.22	34.25	57.82	74	-16.18	PK
4960	33.99	V	33.98	10.22	34.25	43.94	54	-10.06	AV
7440	/	/	/	/	/	/	/	/	/
9920	/	/	/	/	/	/	/	/	/
4960	46.58	H	33.98	10.22	34.25	56.53	74	-17.47	PK
4960	32.12	H	33.98	10.22	34.25	42.07	54	-11.93	AV
7440	/	/	/	/	/	/	/	/	/
9920	/	/	/	/	/	/	/	/	/

Note:

1, Result = Read level + Antenna factor + cable loss-Amp factor

2, All the other emissions not reported were too low to read and deemed to comply with FCC limit.

Conducted RF Spurious Emission

Tx. Spurious NVNT BLE 1M 2402MHz Ant1 Ref



Date: 16.07.2023 10:09:55

Tx. Spurious NVNT BLE 1M 2402MHz Ant1 Emission

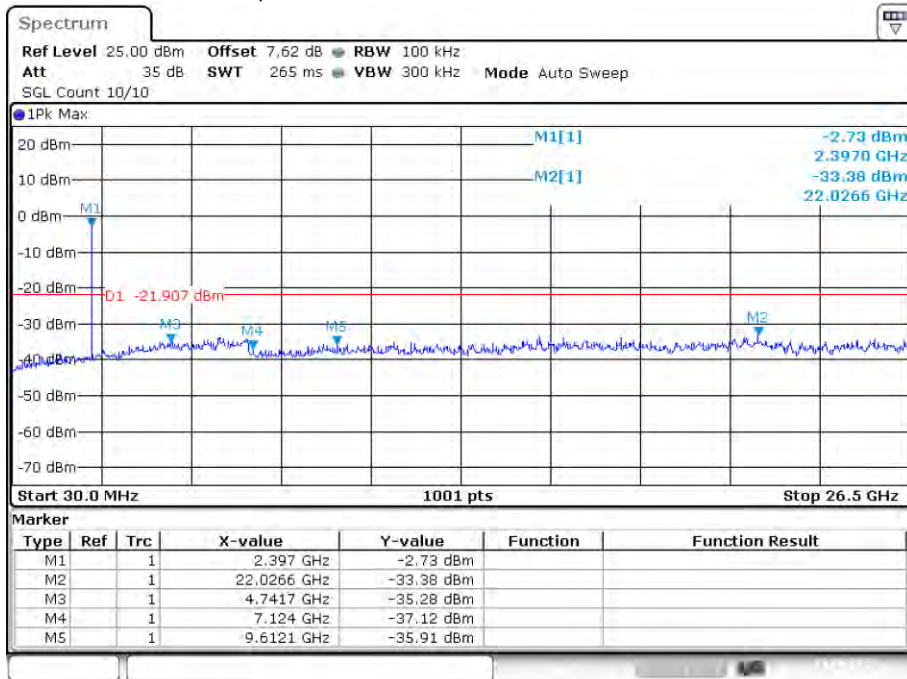

Date: 16.07.2023 10:10:13

Tx. Spurious NVNT BLE 1M 2440MHz Ant1 Ref



Date: 16.07N.2023 10:12:23

Tx. Spurious NVNT BLE 1M 2440MHz Ant1 Emission

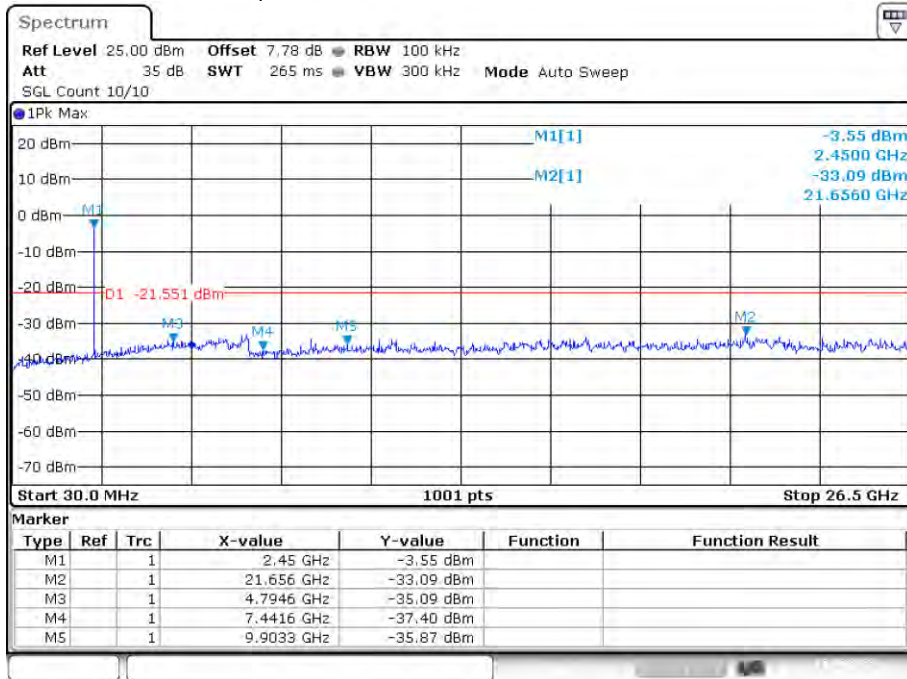

Date: 16.07N.2023 10:12:41

Tx. Spurious NVNT BLE 1M 2480MHz Ant1 Ref



Date: 16.03N.2023 10:16:43

Tx. Spurious NVNT BLE 1M 2480MHz Ant1 Emission

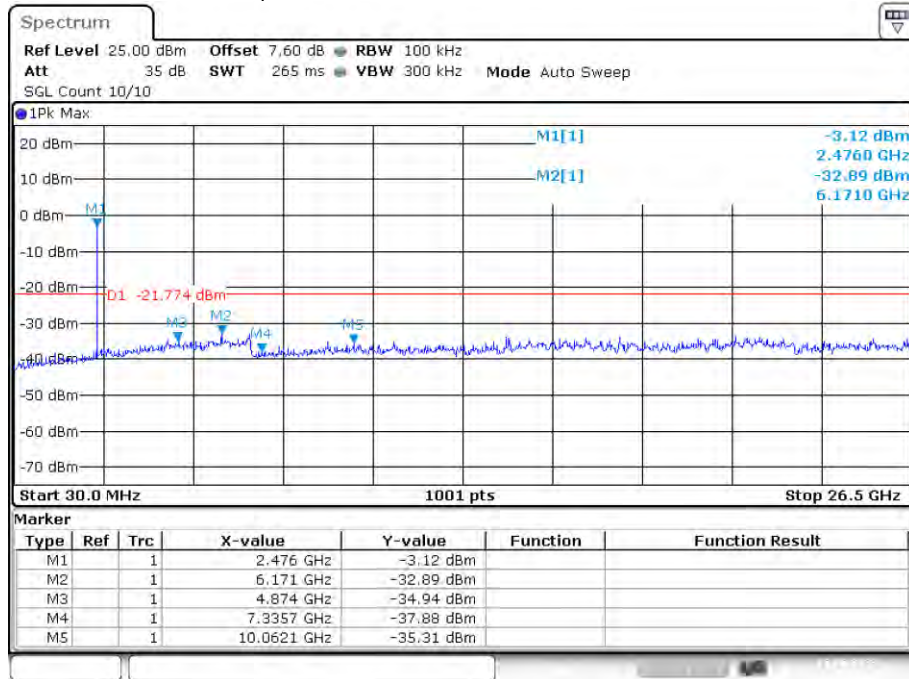

Date: 16.03N.2023 10:17:01

Tx. Spurious NVNT BLE 2M 2402MHz Ant1 Ref



Date: 16.07.2023 10:20:39

Tx. Spurious NVNT BLE 2M 2402MHz Ant1 Emission

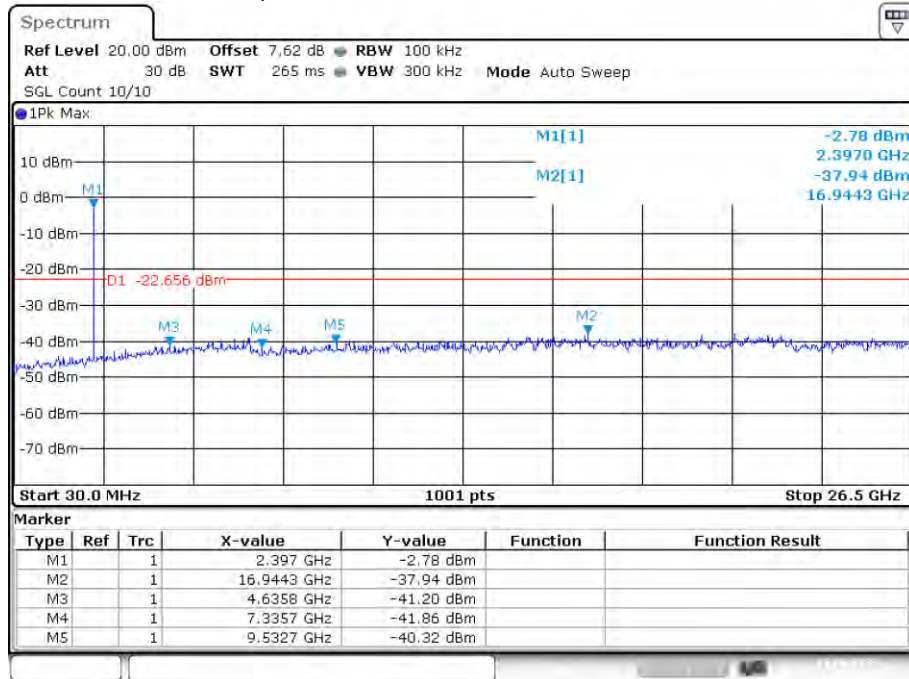

Date: 16.07.2023 10:20:57

Tx. Spurious NVNT BLE 2M 2440MHz Ant1 Ref



Date: 16.07N.2023 10:31:03

Tx. Spurious NVNT BLE 2M 2440MHz Ant1 Emission

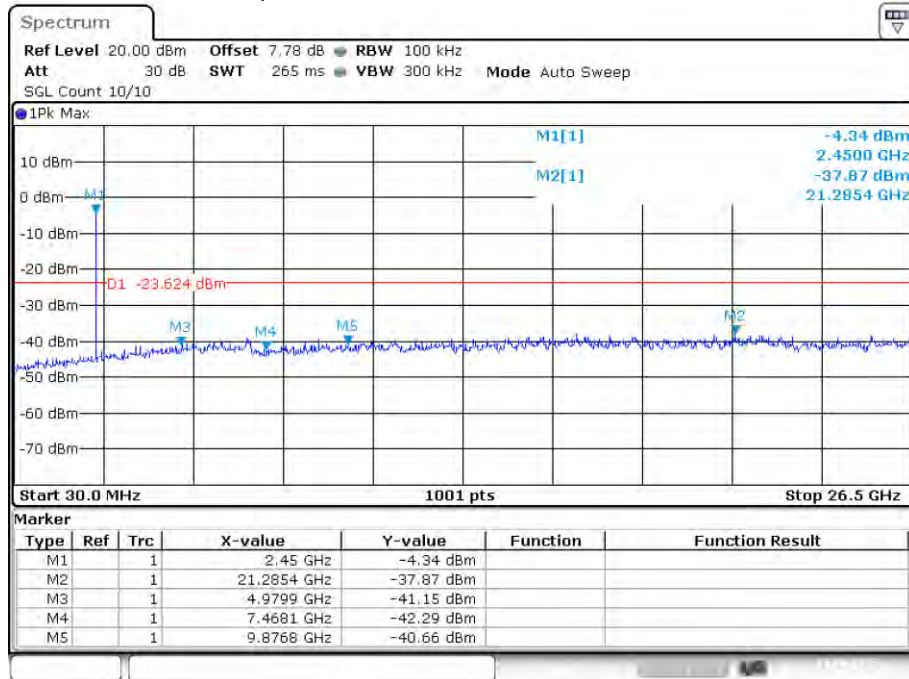

Date: 16.07N.2023 10:31:21

Tx. Spurious NVNT BLE 2M 2480MHz Ant1 Ref



Date: 16.07N.2023 10:29:00

Tx. Spurious NVNT BLE 2M 2480MHz Ant1 Emission

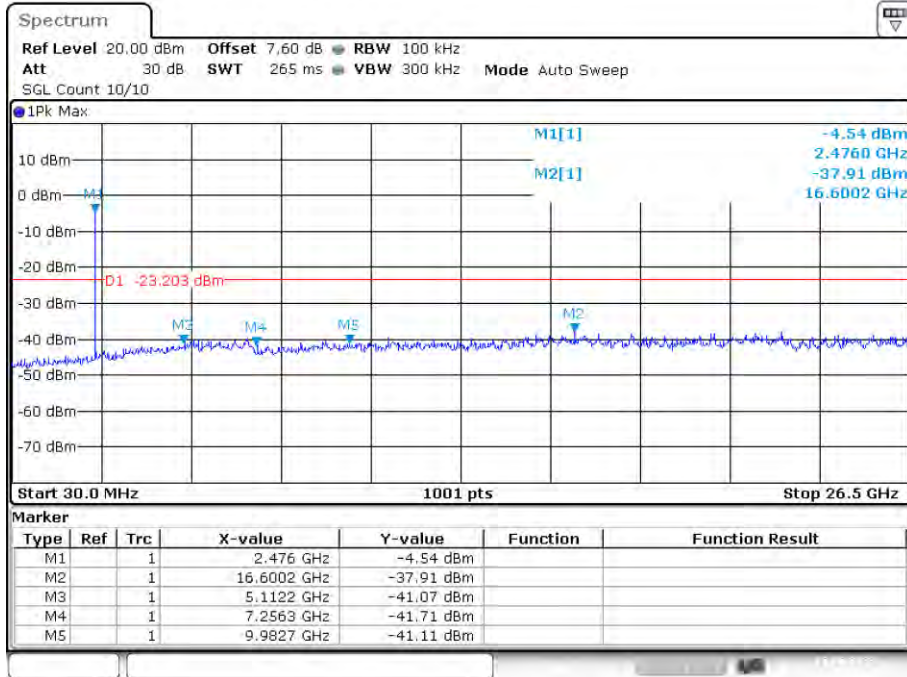

Date: 16.07N.2023 10:29:18

4. POWER LINE CONDUCTED EMISSION

4.1. Test Limits

Frequency MHz	Limits dB(μ V)	
	Quasi-peak Level	Average Level
0.15 -0.50	66 -56*	56 - 46*
0.50 -5.00	56	46
5.00 -30.00	60	50

Notes: 1. *Decreasing linearly with logarithm of frequency.

2. The lower limit shall apply at the transition frequencies.

3. The limit decreases in line with the logarithm of the frequency in rang of 0.15 to 0.50 MHz.

4.2. Test Procedure

The EUT is put on the plane 0.8m high above the ground by insulating support and is connected to the power mains through a line impedance stabilization network (L.I.S.N.). This provides a 50ohm coupling impedance for the EUT system. Please refer the block diagram of the test setup and photographs. Both sides of AC lines are checked to find out the maximum conducted emission. In order to find the maximum emission levels, the relative positions of equipment and all of the interface cables shall be changed according to ANSI C63.10:2013 on Conducted Emission Measurement.

The bandwidth of test receiver is set at 9 kHz.

4.3. Test Setup

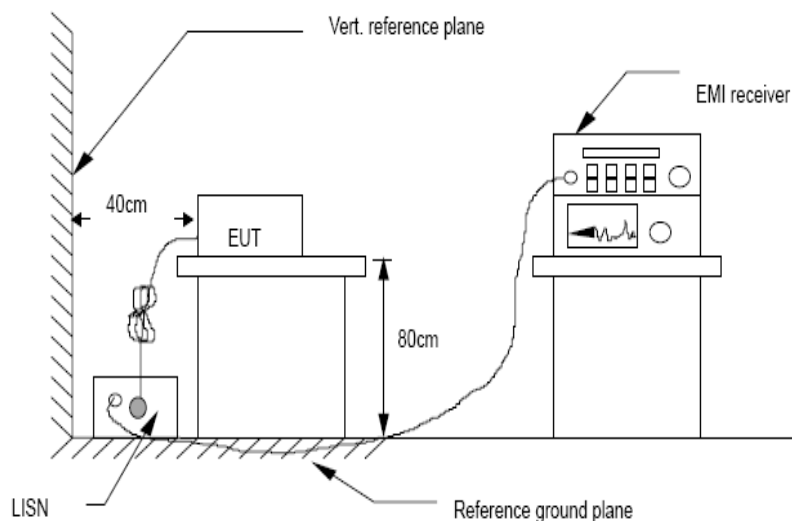

4.4. Test Results

Pass

Line:

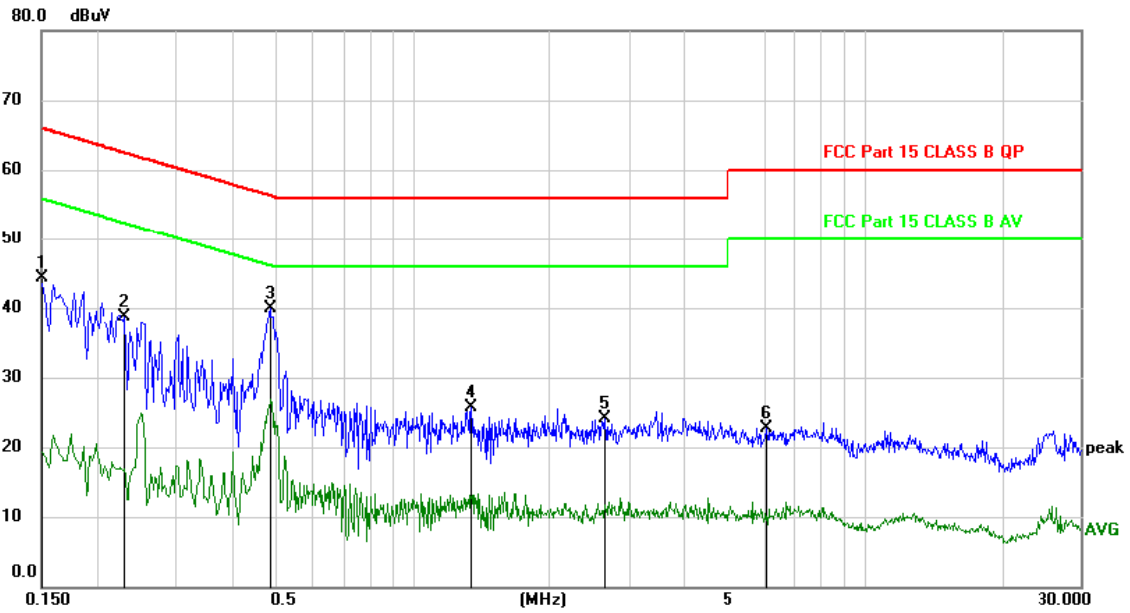

No.	Mk.	Freq. MHz	Reading Level dBuV	Correct Factor dB	Measure- ment dBuV	Limit dBuV	Margin dB	Detector	Comment
1		0.1500	34.54	9.83	44.37	66.00	-21.63	peak	
2		0.2310	28.95	9.83	38.78	62.41	-23.63	peak	
3	*	0.4830	30.10	9.83	39.93	56.29	-16.36	peak	
4		1.3470	15.95	9.82	25.77	56.00	-30.23	peak	
5		2.6550	14.37	9.79	24.16	56.00	-31.84	peak	
6		6.0690	12.82	9.91	22.73	60.00	-37.27	peak	

*:Maximum data x:Over limit !:over margin

<Reference Only

Note: Measurement=Reading Level+Correc Factor. Factor=(LISN or ISN or PLC or Current Probe)Factor+Cable

Neutral:

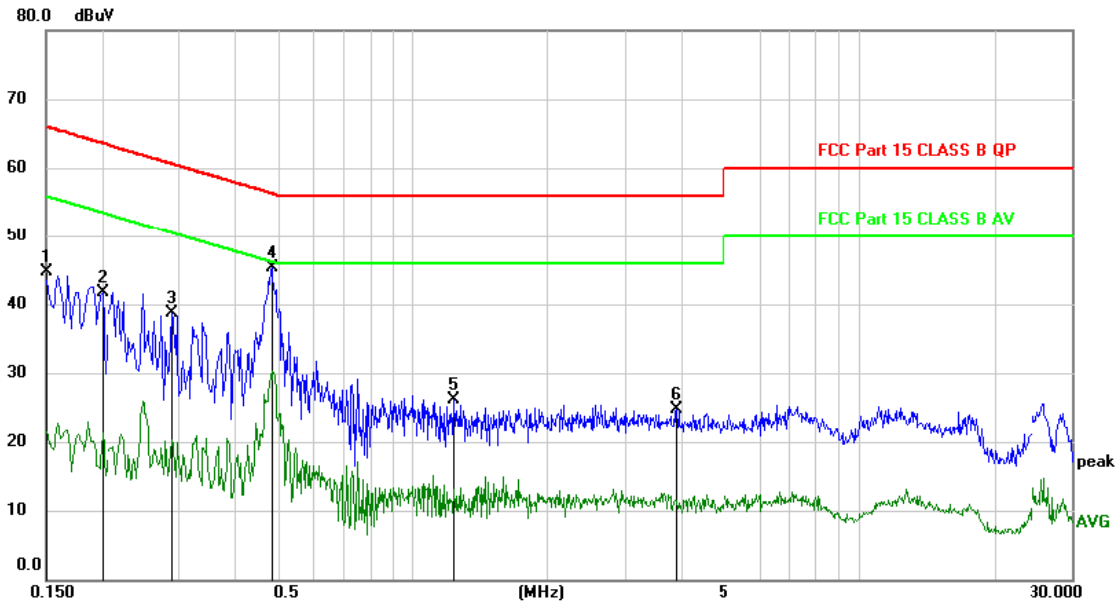

No.	Mk.	Freq. MHz	Reading Level dBuV	Correct Factor dB	Measure- ment dBuV	Limit dBuV	Margin dB	Detector	Comment
1		0.1500	34.95	9.83	44.78	66.00	-21.22	peak	
2		0.2010	31.85	9.83	41.68	63.57	-21.89	peak	
3		0.2880	28.87	9.83	38.70	60.58	-21.88	peak	
4	*	0.4830	35.52	9.83	45.35	56.29	-10.94	peak	
5		1.2390	16.26	9.82	26.08	56.00	-29.92	peak	
6		3.8940	14.81	9.84	24.65	56.00	-31.35	peak	

*:Maximum data x:Over limit !:over margin

⟨Reference Only

Note: Measurement=Reading Level+Correc Factor. Factor=(LISN or ISN or PLC or Current Probe)Factor+Cable

Remark: This report only shall the worst case mode for TX 2440MHz(1Mbps), and the power supply mode is DC 12V from adapter with AC 120V/60Hz

5. CONDUCTED MAXIMUM OUTPUT POWER

5.1. Test limits

Please refer section RSS-247 & 15.247.

5.2. Test Procedure

Details see the KDB558074 D01 Meas Guidance v05r02

5.2.1 Place the EUT on the table and set it in transmitting mode.

5.2.2 Measure out each mode and each bands peak output power of EUT.

Note: The cable loss and attenuator loss were offset into measure device as amplitude offset.

5.3. Test Setup

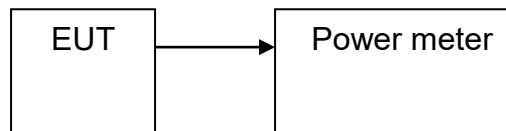

5.4. Test Results

Mode	Frequency (MHz)	Antenna	Conducted Power (dBm)	Duty Factor (dB)	Total Power (dBm)	Limit (dBm)	Verdict
1M	2402	Ant1	-0.216	0	-0.216	30	Pass
1M	2440	Ant1	-0.737	0	-0.737	30	Pass
1M	2480	Ant1	-0.564	0	-0.564	30	Pass

Mode	Frequency (MHz)	Antenna	Conducted Power (dBm)	Duty Factor (dB)	Total Power (dBm)	Limit (dBm)	Verdict
2M	2402	Ant1	0.3	0	0.3	30	Pass
2M	2440	Ant1	0.072	0	0.072	30	Pass
2M	2480	Ant1	-0.174	0	-0.174	30	Pass

6. PEAK POWER SPECTRAL DENSITY

6.1. Test limits

6.1.1 Please refer section RSS-247 & 15.247.

6.1.2 For direct sequence systems, the peak power spectral density conducted from the intentional radiator to the antenna shall not be greater than 8dBm in any 3kHz band during any time interval of continuous transmission.

6.1.3 The direct sequence operating of the hybrid system, with the frequency hopping operation turned off, shall comply with the power density requirements of paragraph (d) of this section.

6.2. Test Procedure

Details see the KDB558074 D01 Meas Guidance v05r02

6.2.1 Place the EUT on the table and set it in transmitting mode.

6.2.2 Remove the antenna from the EUT and then connect a low loss RF cable from the antenna port to the spectrum analyzer.

6.2.3 Set the spectrum analyzer as RBW = 3kHz(Set the RBW to: $3\text{ kHz} \leq \text{RBW} \leq 100\text{ kHz}$.), VBW = 10kHz(Set the $\text{VBW} \geq 3 \times \text{RBW}$), span $\geq 1.5 \times \text{DTS bandwidth}$., detail see the test plot.

6.2.4 Record the max reading.

6.2.5 Repeat the above procedure until the measurements for all frequencies are completed.

6.3. Test Setup

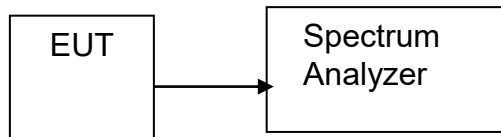

6.4. Test Results

Condition	Mode	Frequency (MHz)	Antenna	Max PSD (dBm)	Limit (dBm)	Verdict
NVNT	1M	2402	Ant1	-16.255	8	Pass
NVNT	1M	2440	Ant1	-16.32	8	Pass
NVNT	1M	2480	Ant1	-16.179	8	Pass

PSD NVNT BLE 1M 2402MHz Ant1

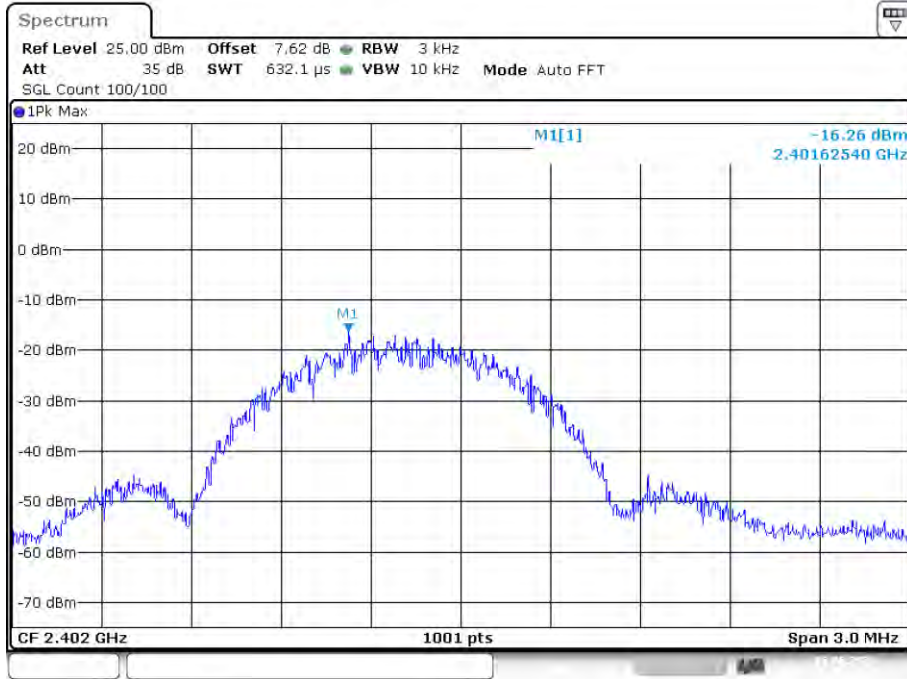

Date: 16.07N.2023 10:09:37

PSD NVNT BLE 1M 2440MHz Ant1

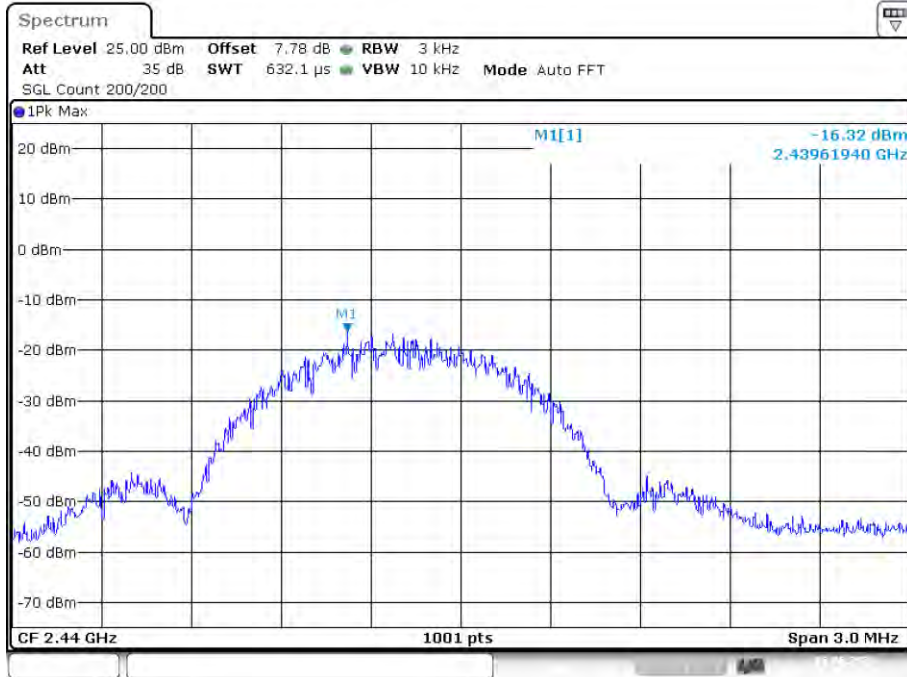

Date: 16.07N.2023 10:12:17

PSD NVNT BLE 1M 2480MHz Ant1

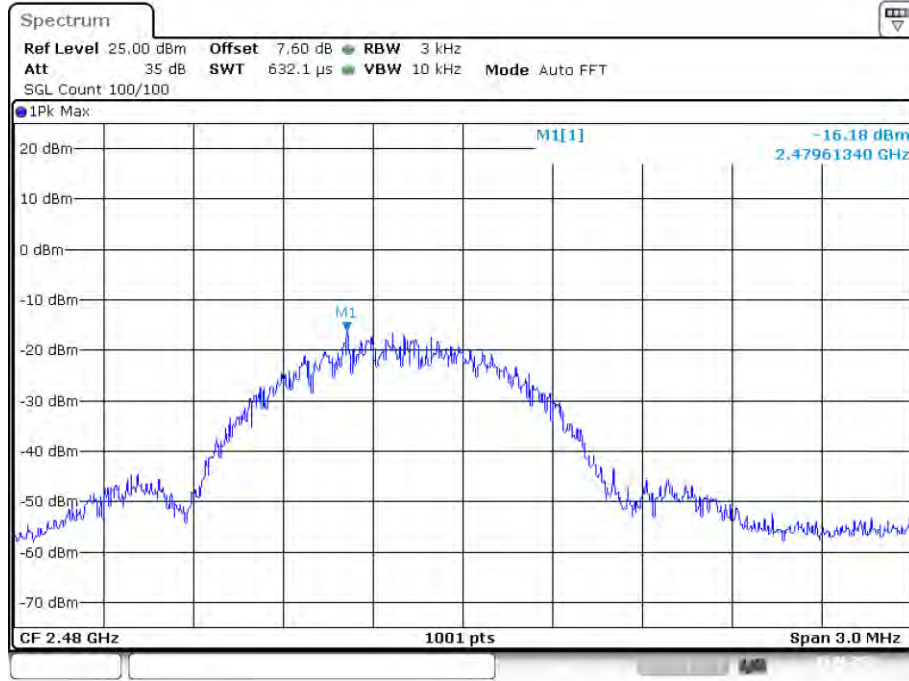

Date: 16 JUN 2023 10:16:23

Condition	Mode	Frequency (MHz)	Antenna	Max PSD (dBm)	Limit (dBm)	Verdict
NVNT	2M	2402	Ant1	-18.527	8	Pass
NVNT	2M	2440	Ant1	-18.59	8	Pass
NVNT	2M	2480	Ant1	-18.85	8	Pass

PSD NVNT BLE 2M 2402MHz Ant1

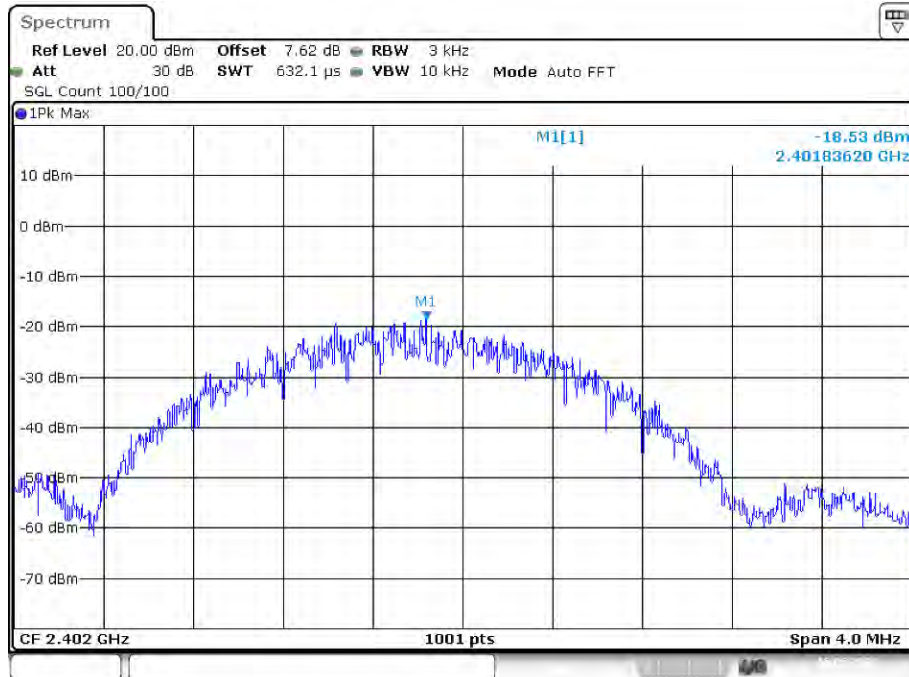

Date: 16 JUN 2023 10:20:21

PSD NVNT BLE 2M 2440MHz Ant1

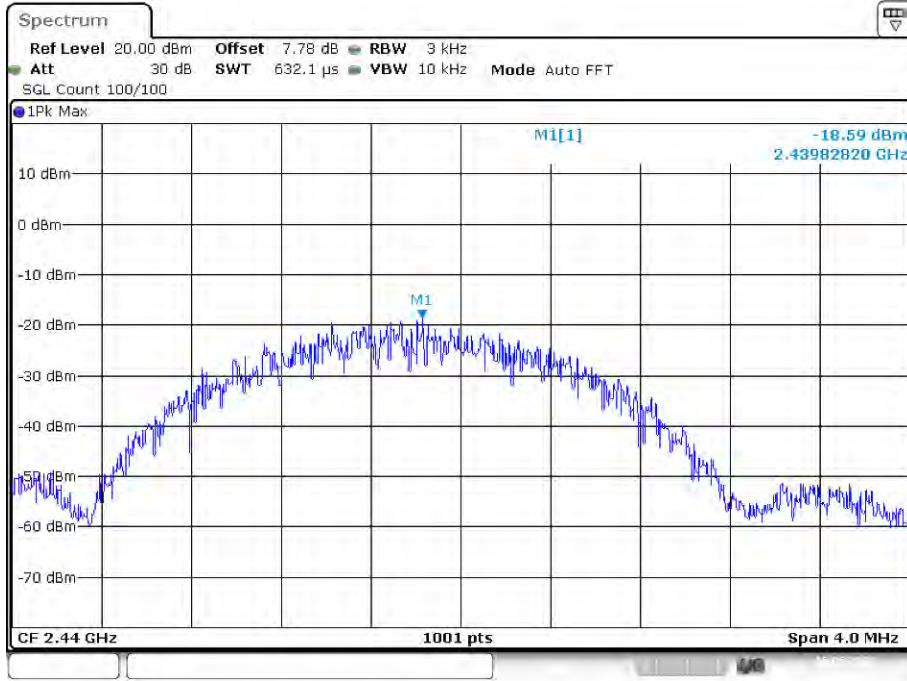

Date: 16.JUN.2023 10:30:56

PSD NVNT BLE 2M 2480MHz Ant1

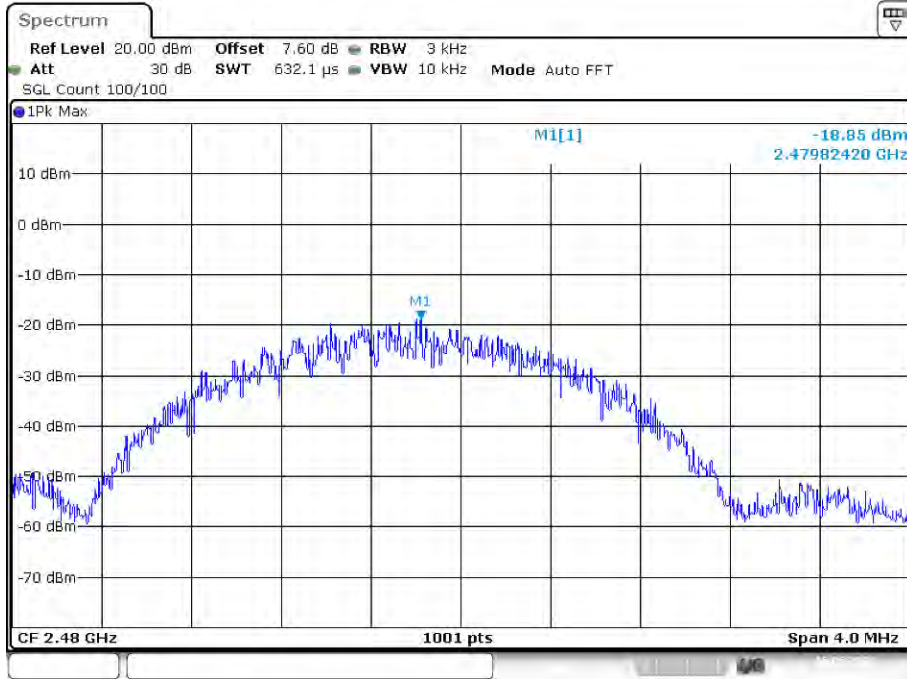

Date: 16.JUN.2023 10:28:40

7. BANDWIDTH

7.1. Test limits

Please refer section RSS-247 & 15.247

For direct sequence systems, the minimum 6dB bandwidth shall be at least 500 kHz.

7.2. Test Procedure

Details see the KDB558074 D01 Meas Guidance v05r02

- a) The bandwidth is measured at an amplitude level reduced 6dB from the reference level. The reference level is the level of the highest amplitude signal observed from the transmitter at the fundamental frequency. Once the reference level is established, the equipment is conditioned with typical modulating signal to produce the worst-case (i.e. the widest) bandwidth.
- b) The test receiver set RBW = 1-5%BW, VBW $\geq 3 \times$ RBW, Sweep time set auto, detail see the test plot for 99% Bandwidth.
- c) The test receiver set RBW = 100kHz, VBW $\geq 3 \times$ RBW = 300kHz, Sweep time set auto, detail see the test plot for 6dB Bandwidth.

7.3. Test Setup

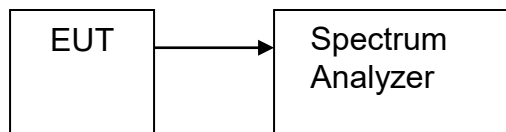

7.4. Test Results

-6dB Bandwidth

Condition	Mode	Frequency (MHz)	Antenna	-6 dB Bandwidth (MHz)	Limit -6 dB Bandwidth (MHz)	Verdict
NVNT	BLE 1M	2402	Ant1	0.78	0.5	Pass
NVNT	BLE 1M	2440	Ant1	0.764	0.5	Pass
NVNT	BLE 1M	2480	Ant1	0.73	0.5	Pass

-6dB Bandwidth NVNT BLE 1M 2402MHz Ant1

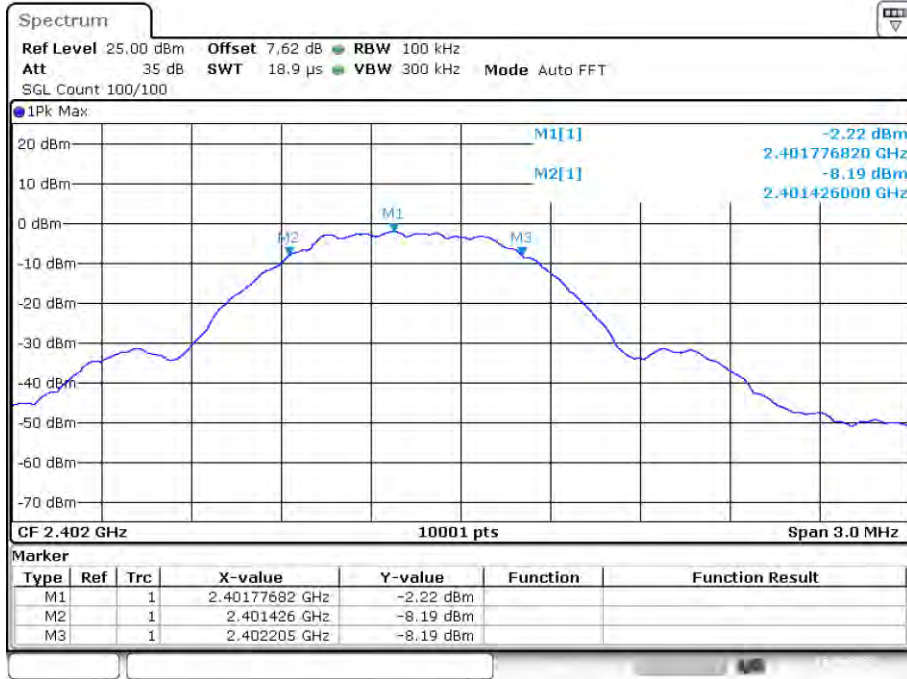

Date: 16.07.2023 10:09:30

-6dB Bandwidth NVNT BLE 1M 2440MHz Ant1

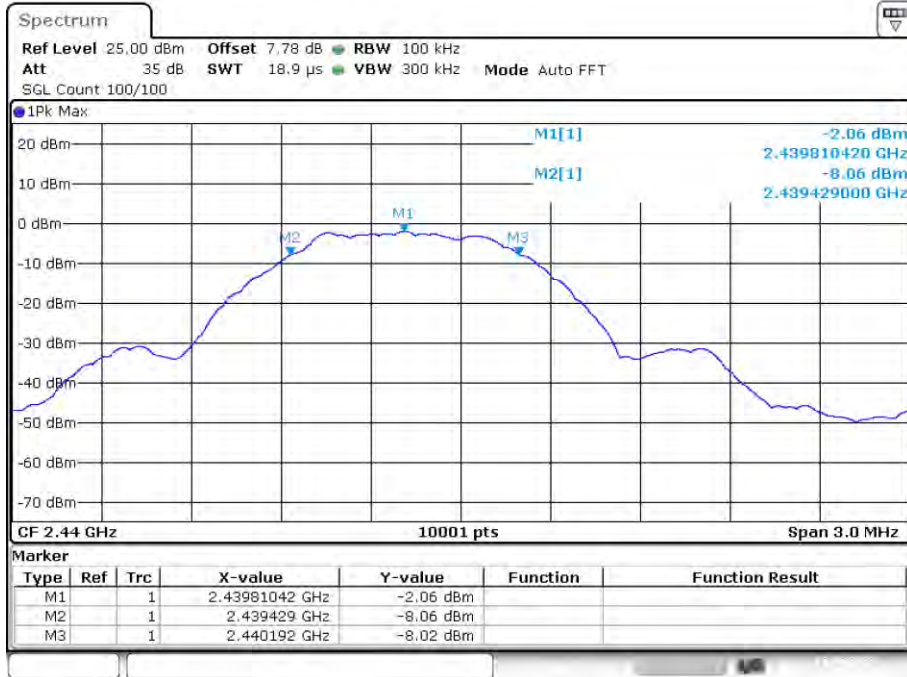

Date: 16.07.2023 10:12:08

-6dB Bandwidth NVNT BLE 1M 2480MHz Ant1

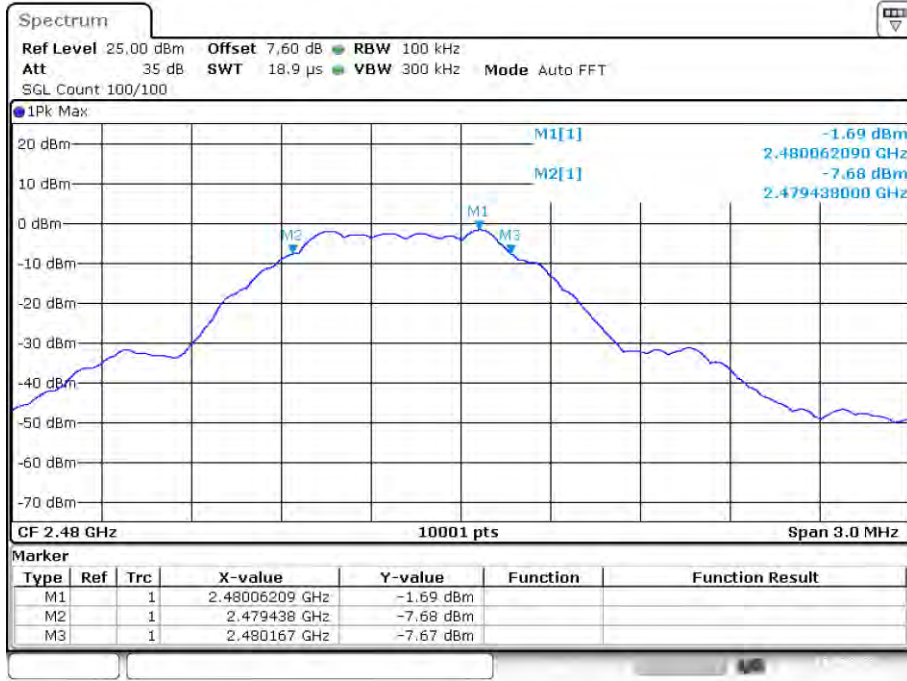

Date: 16.07.2023 10:16:14

Occupied Channel Bandwidth

Condition	Mode	Frequency (MHz)	Antenna	99% OBW (MHz)
NVNT	BLE 1M	2402	Ant1	1.043
NVNT	BLE 1M	2440	Ant1	1.052
NVNT	BLE 1M	2480	Ant1	1.049

OBW NVNT BLE 1M 2402MHz Ant1

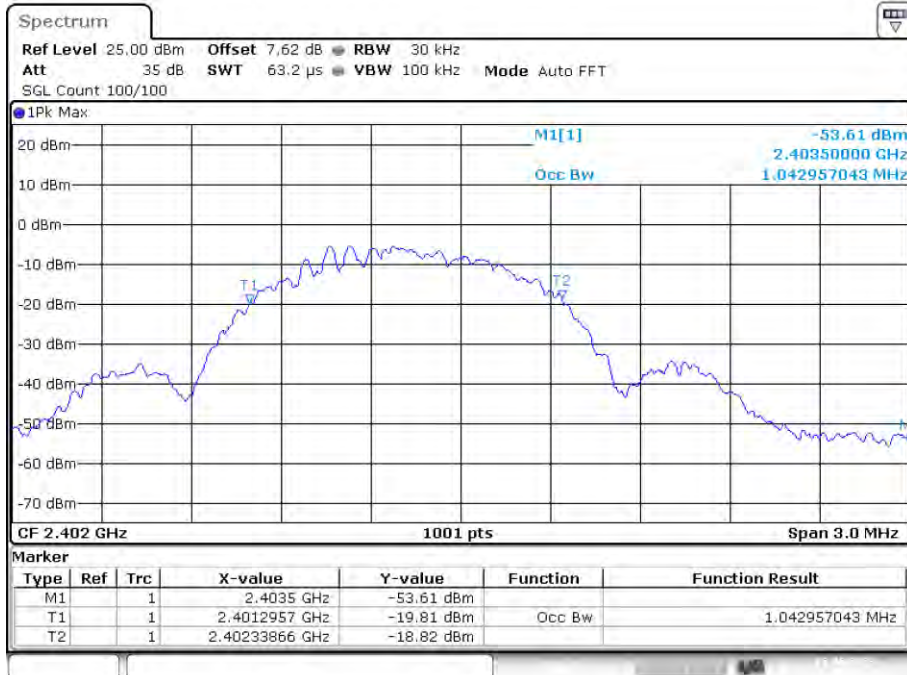

Date: 16.07.2023 10:09:21

OBW NVNT BLE 1M 2440MHz Ant1



Date: 16.07.2023 10:12:00

OBW NVNT BLE 1M 2480MHz Ant1

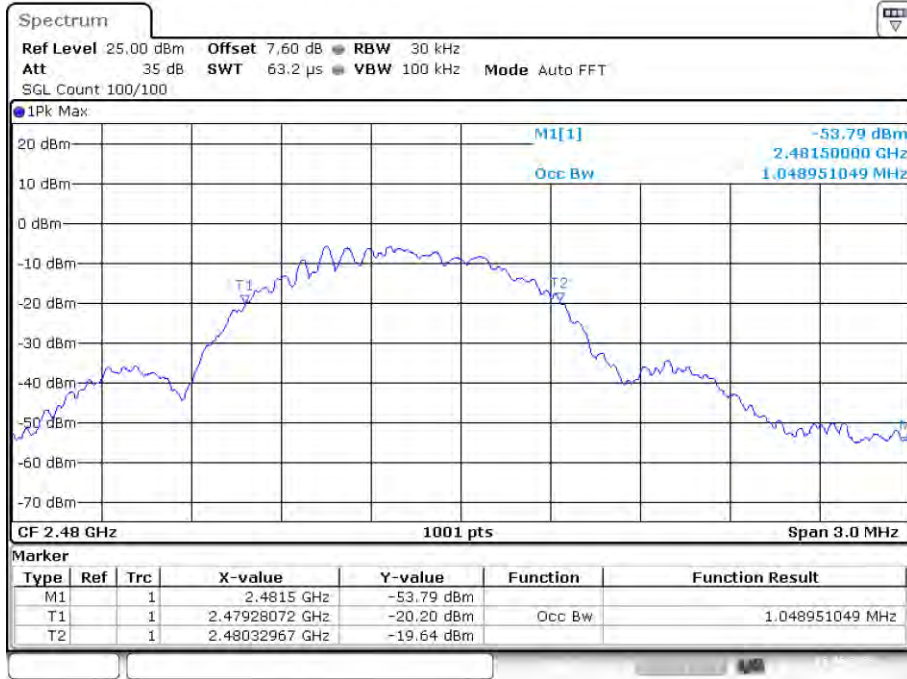

Date: 16.07.2023 10:16:04

-6dB Bandwidth

Condition	Mode	Frequency (MHz)	Antenna	-6 dB Bandwidth (MHz)	Limit -6 dB Bandwidth (MHz)	Verdict
NVNT	BLE 2M	2402	Ant1	1.372	0.5	Pass
NVNT	BLE 2M	2440	Ant1	1.389	0.5	Pass
NVNT	BLE 2M	2480	Ant1	1.402	0.5	Pass

-6dB Bandwidth NVNT BLE 2M 2402MHz Ant1

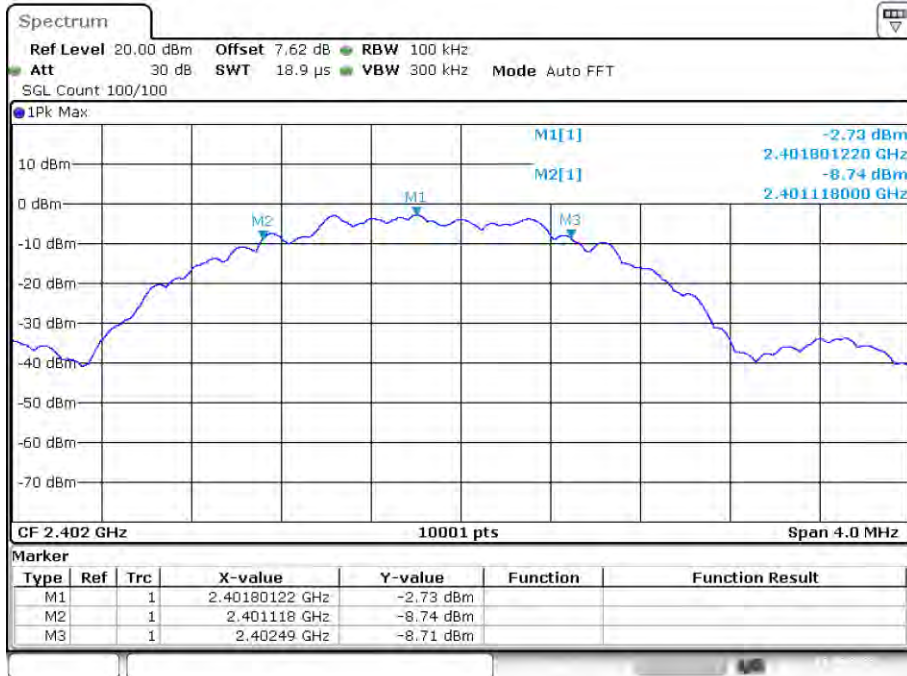

Date: 16.07.2023 10:20:14

-6dB Bandwidth NVNT BLE 2M 2440MHz Ant1

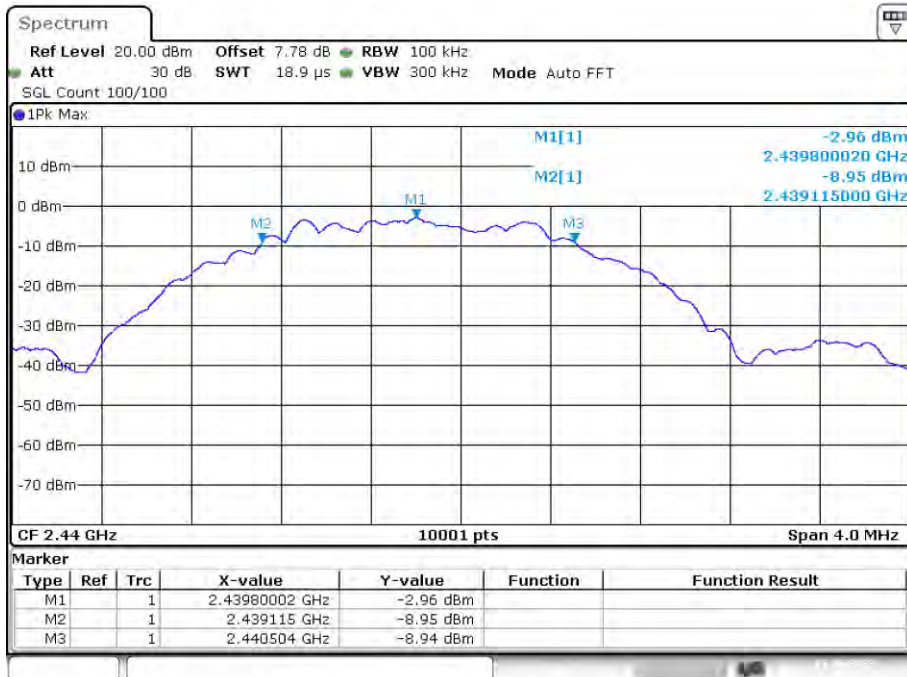

Date: 16.07.2023 10:30:46

-6dB Bandwidth NVNT BLE 2M 2480MHz Ant1

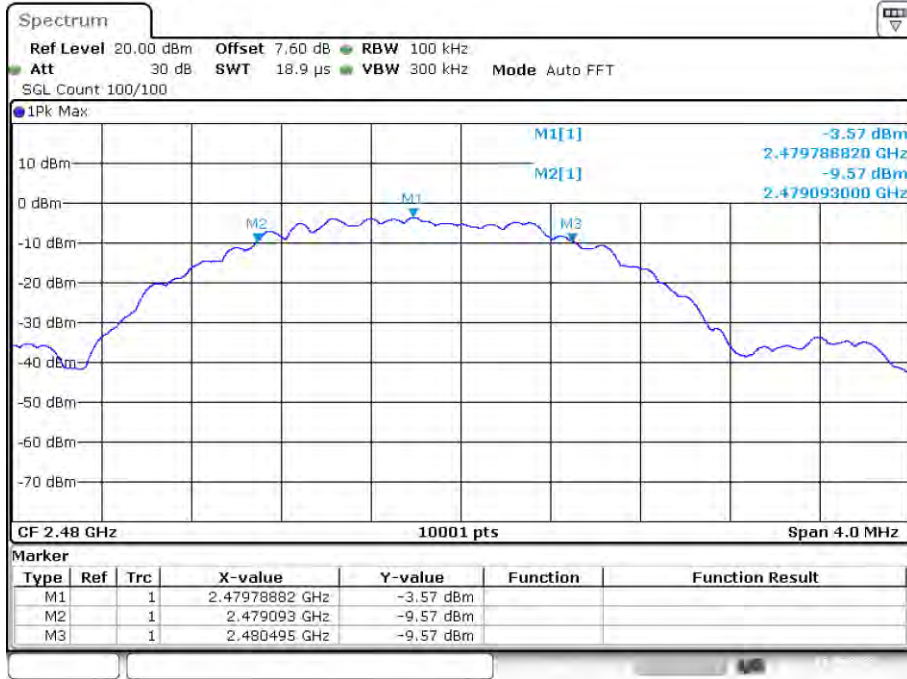

Date: 16.09.2023 10:28:32

Occupied Channel Bandwidth

Condition	Mode	Frequency (MHz)	Antenna	99% OBW (MHz)
NVNT	BLE 2M	2402	Ant1	2.034
NVNT	BLE 2M	2440	Ant1	2.05
NVNT	BLE 2M	2480	Ant1	2.058

OBW NVNT BLE 2M 2402MHz Ant1

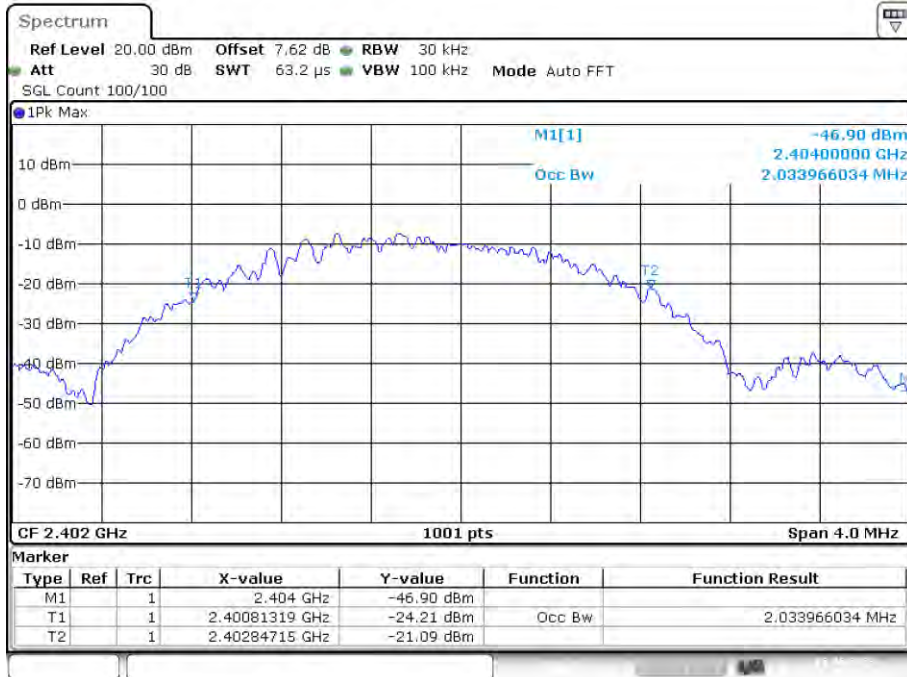

Date: 16.09.2023 10:20:07

OBW NVNT BLE 2M 2440MHz Ant1



Date: 16.07N.2023 10:30:37

OBW NVNT BLE 2M 2480MHz Ant1



Date: 16.07N.2023 10:28:23

8. BAND EDGE CHECK

8.1. Test limits

Please refer section RSS-GEN&15.247.

8.2. Test Procedure

Details see the KDB558074 D01 Meas Guidance v05r02

8.2.1 Put the EUT on a 1.5m high table, power on the EUT. Emissions were scanned and measured rotating the EUT to 360 degrees, Find the maximum Emission

8.2.2 Check the spurious emissions out of band.

8.2.3 RBW 1MHz, VBW 3MHz, peak detector for peak value, RBW 1MHz, VBW 3MHz, RMS detector for AV value.

8.3. Test Setup

Same as 3.3 above 1GHz.

8.4. Test Results

GFSK 1Mbps Mode:

Band Edge NVLT BLE 2402MHz Ant1

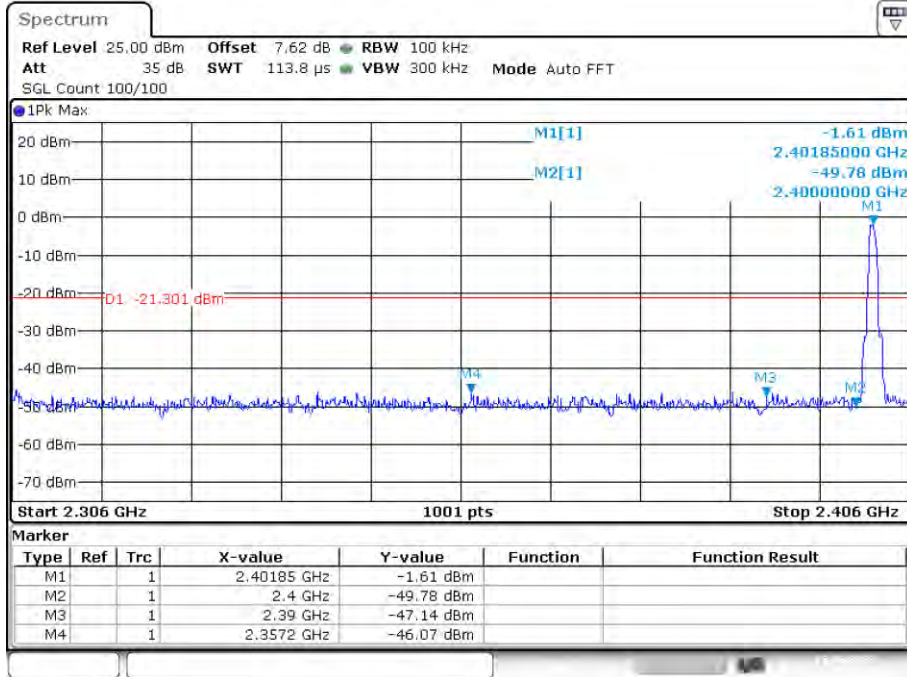

Band Edge NVLT BLE 2480MHz Ant1

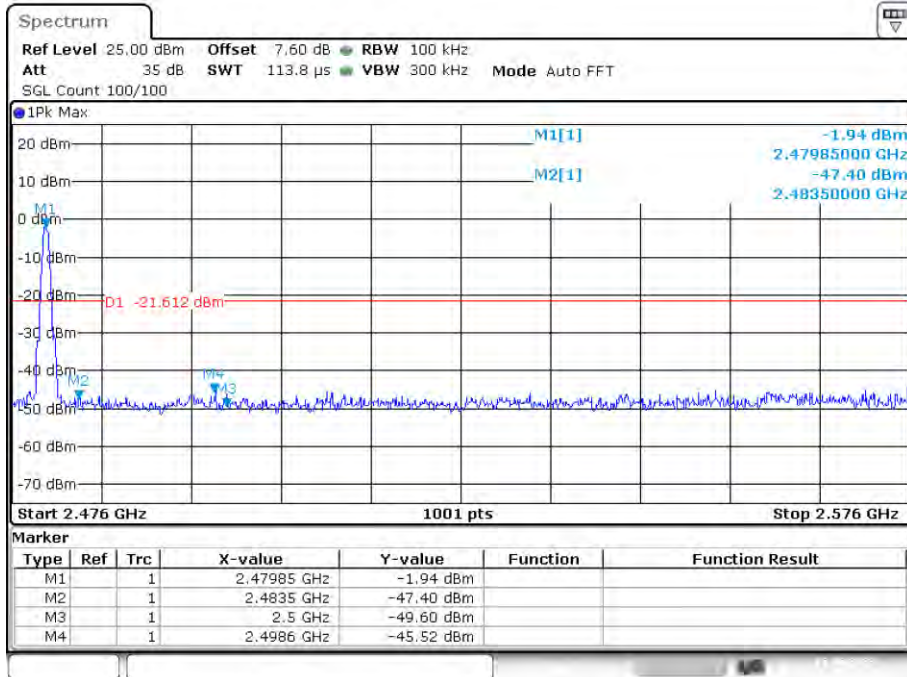

GFSK 1Mbps Mode:

Test channel: Lowest channel

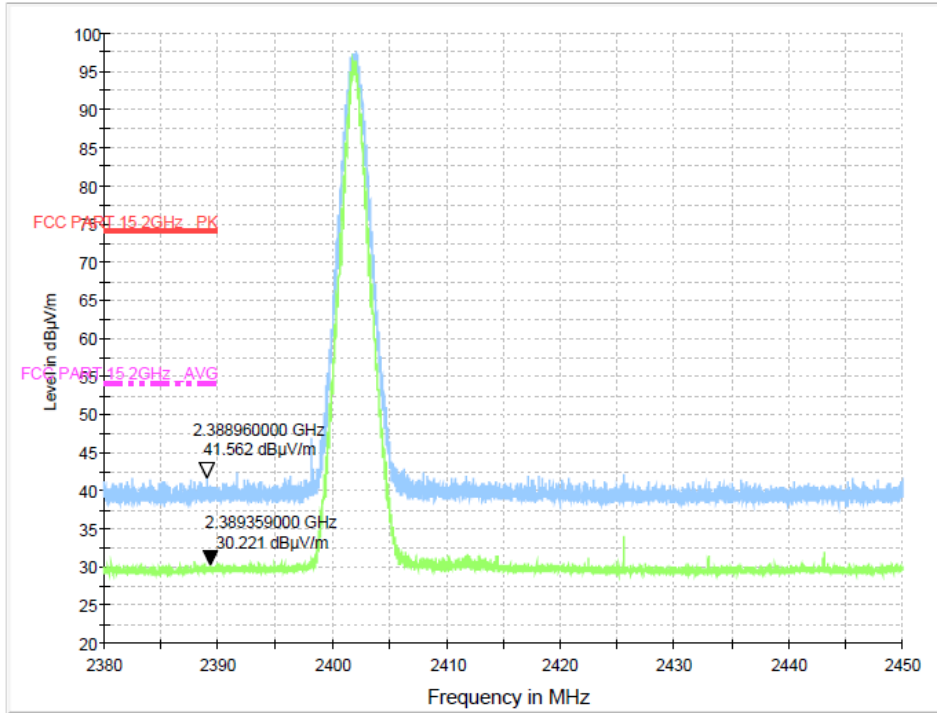

Test channel: Highest channel

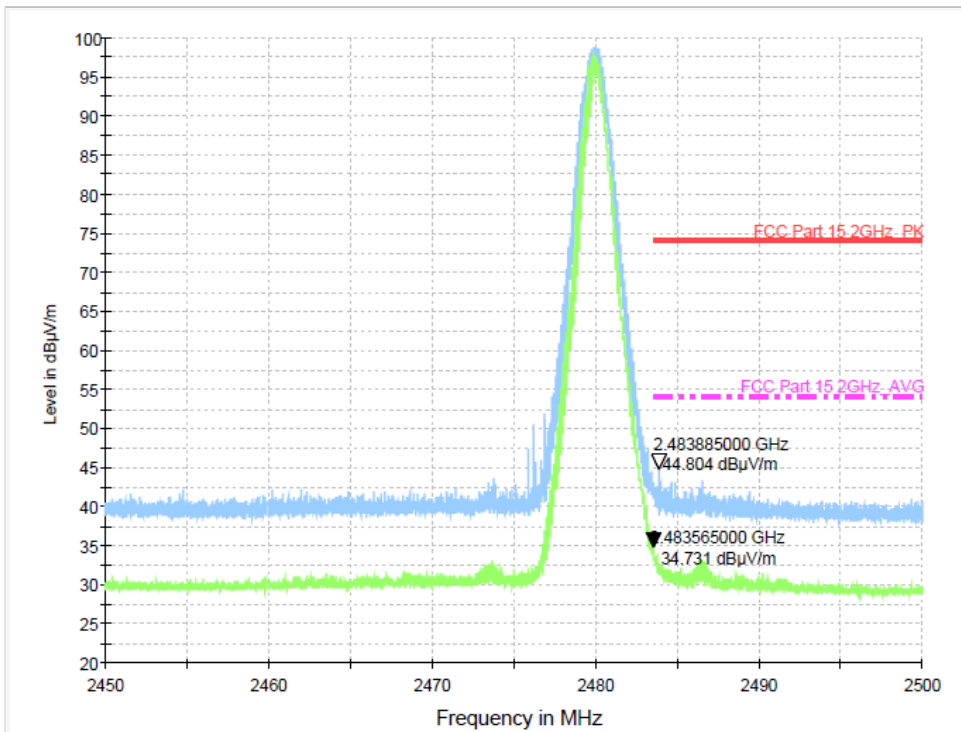

GFSK 2Mbps Mode:

Band Edge NVLT BLE 2402MHz Ant1

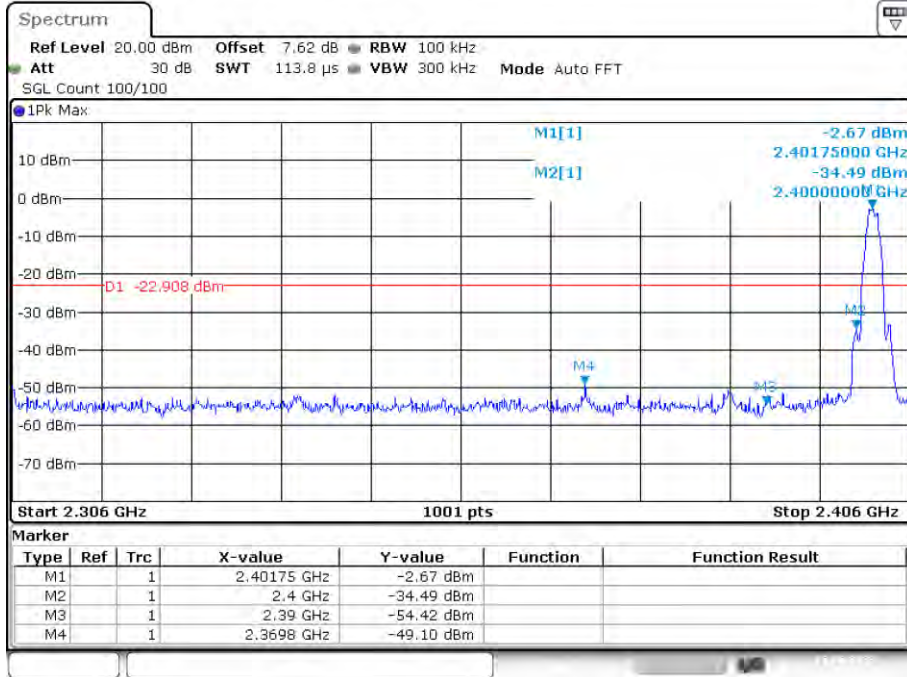

Band Edge NVLT BLE 2480MHz Ant1

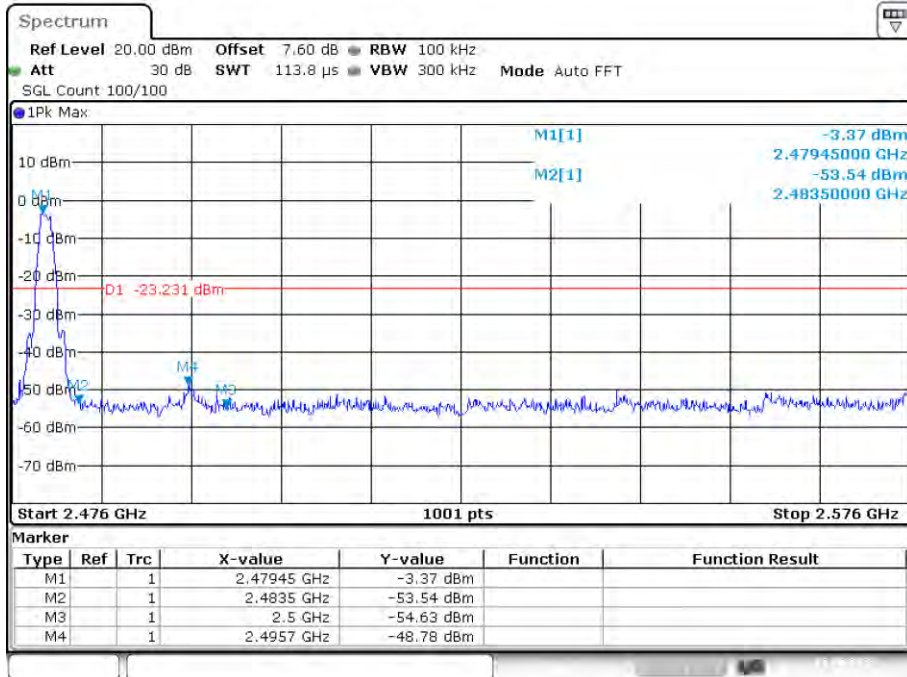

GFSK 2Mbps Mode:

Test channel: Lowest channel

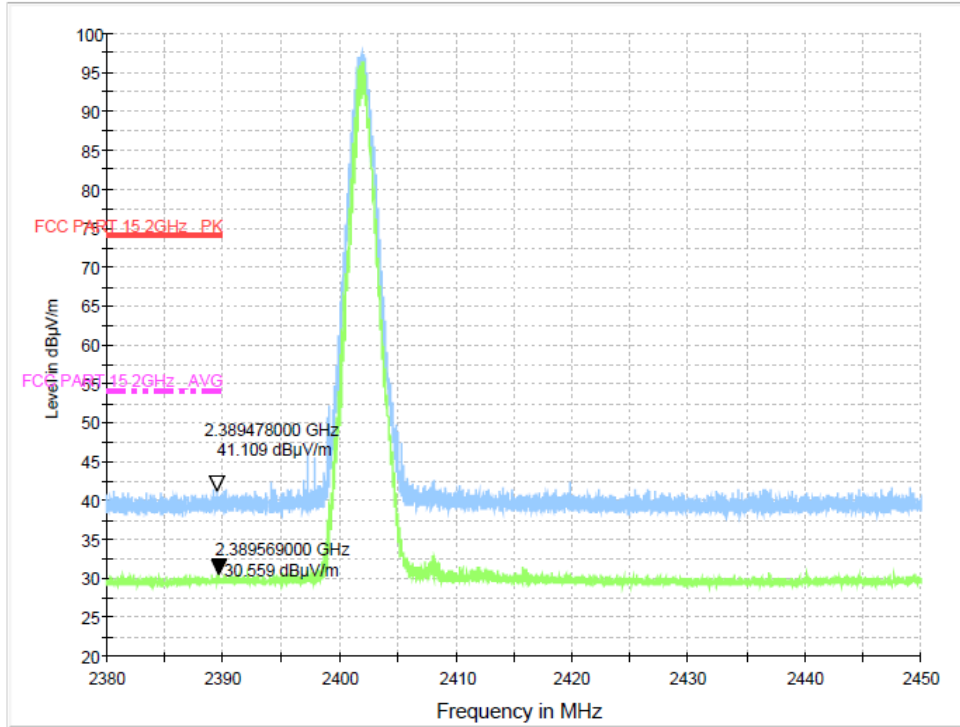

Test channel: Highest channel

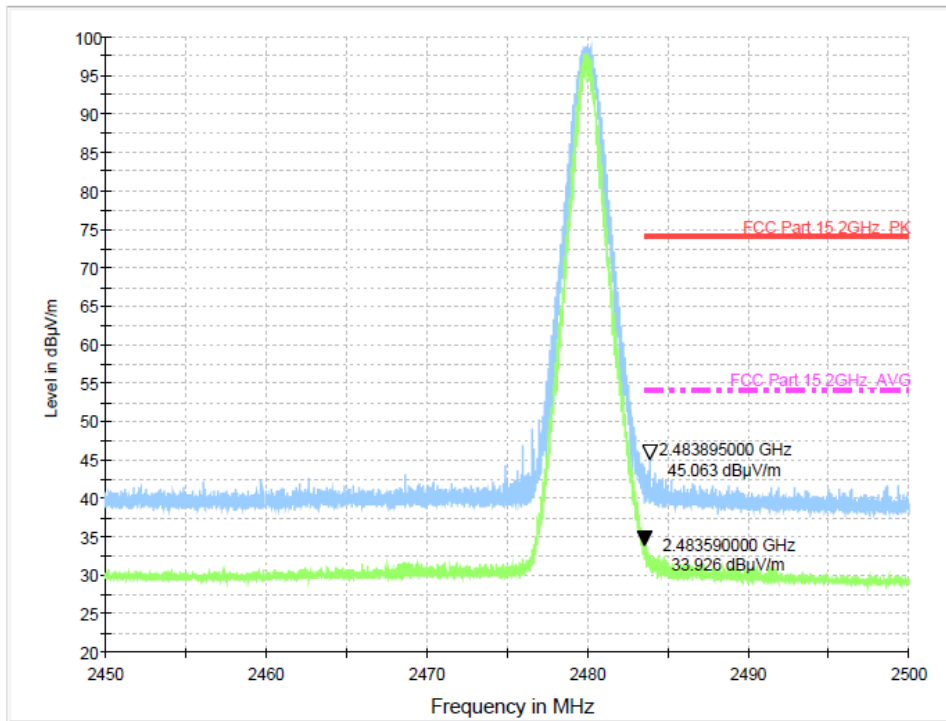

9. FREQUENCY STABILITY

9.1. Test limit

Please refer section RSS-Gen.

Regulation RSS-Gen If the frequency stability of the licence-exempt radio apparatus is not specified in the applicable RSS, the fundamental emissions of the radio apparatus should be kept within at least the central 80% of its permitted operating frequency band in order to minimize the possibility of out-of-band operation. In addition, its occupied bandwidth shall be entirely outside the restricted bands and the prohibited TV bands of 54-72 MHz, 76-88 MHz, 174-216 MHz, and 470-602 MHz, unless otherwise indicated.

9.2. Test Procedure

The following equipment are installed on the emission measurement to meet the commission requirements and operating regulations in a manner which tends to maximize its emission characteristics in normal application.

9.3. Test Setup

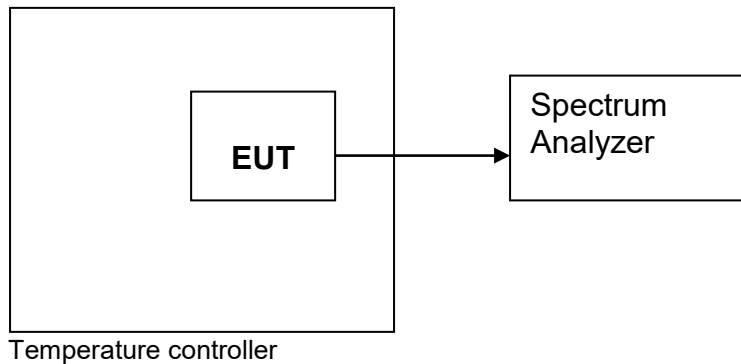

9.4. Test Results

N/A

10. ANTENNA REQUIREMENT

10.1. Standard Requirement

An intentional radiator shall be designed to ensure that no antenna other than that furnished by the responsible party shall be used with the device. The use of a permanently attached antenna or of an antenna that uses a unique coupling to the intentional radiator shall be considered sufficient to comply with the provisions of this Section. The manufacturer may design the unit so that a broken antenna can be replaced by the user, but the use of a standard antenna jack or electrical connector is prohibited.

10.2. Antenna Connected Construction

The antenna is Internal antenna and no consideration of replacement. Please see EUT photo for details.

10.3. Results

The EUT antenna is Internal Antenna. It comply with the standard requirement.

11. Test Setup Photo

11.1. Photos of Radiated emission

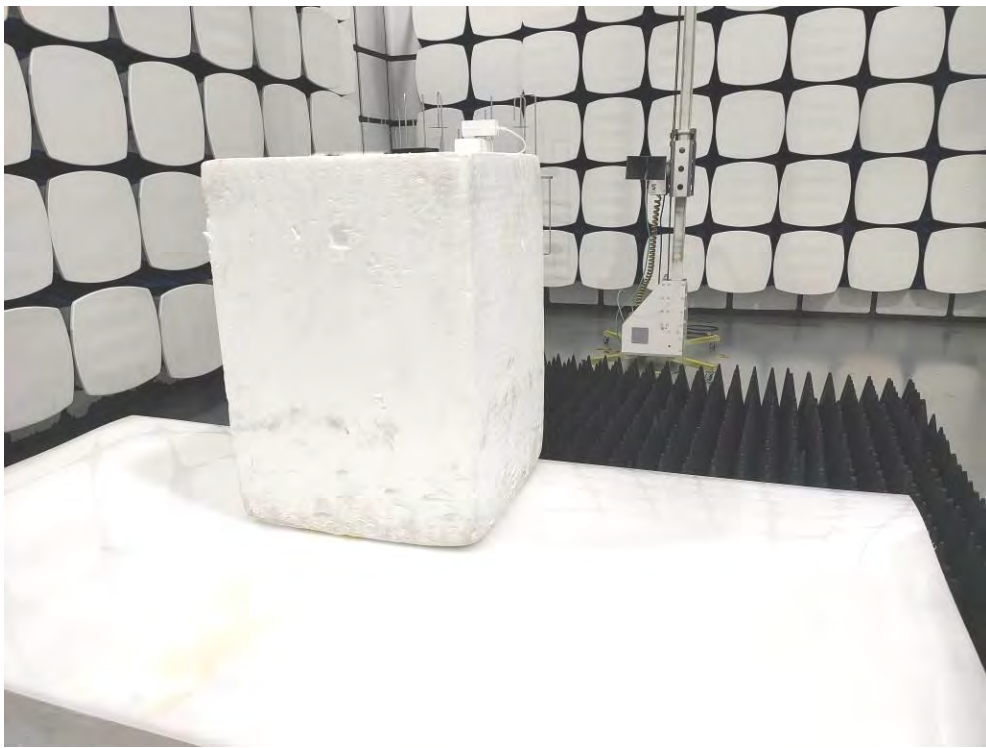
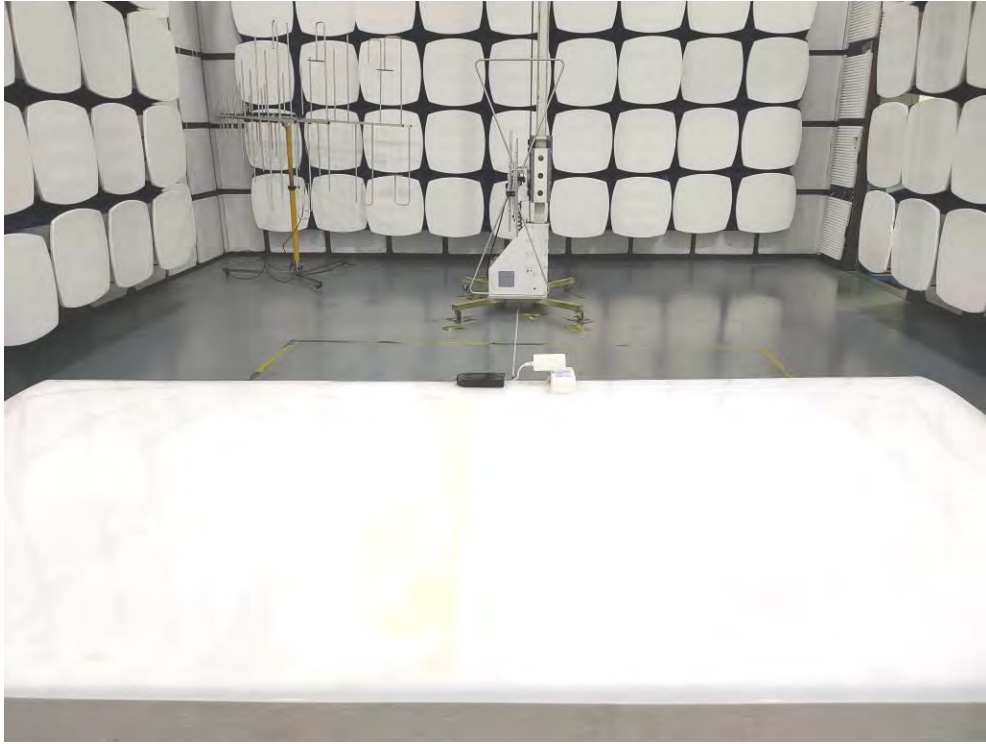

11.2.Photos of Conducted Emission test



12. EUT PHOTO





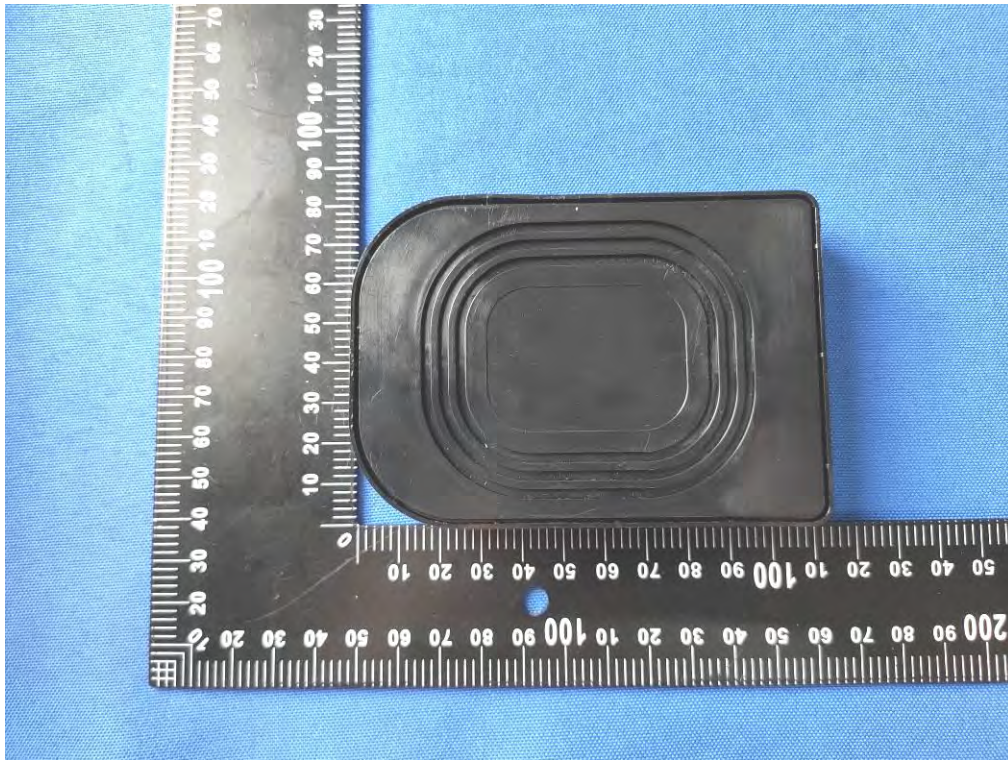



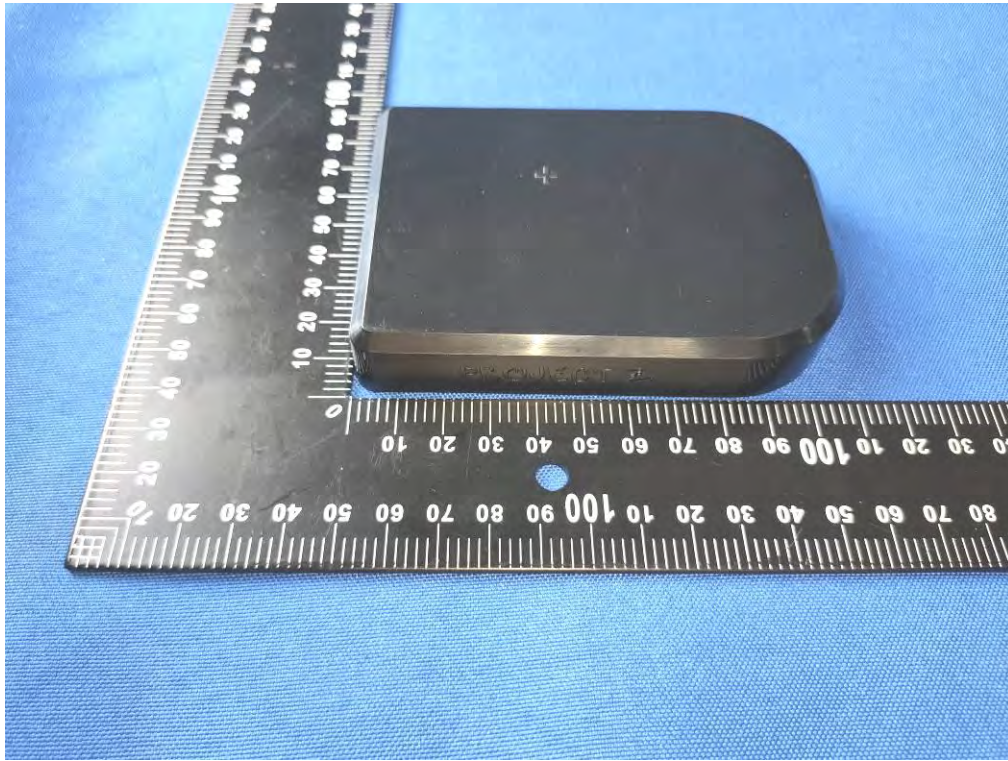

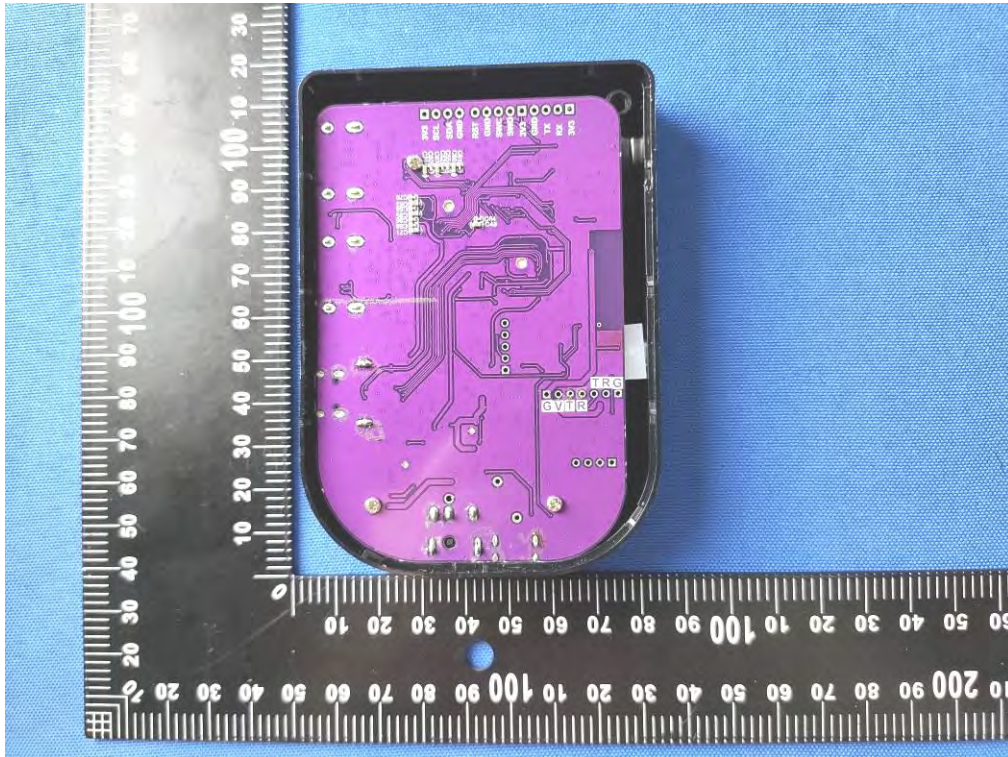
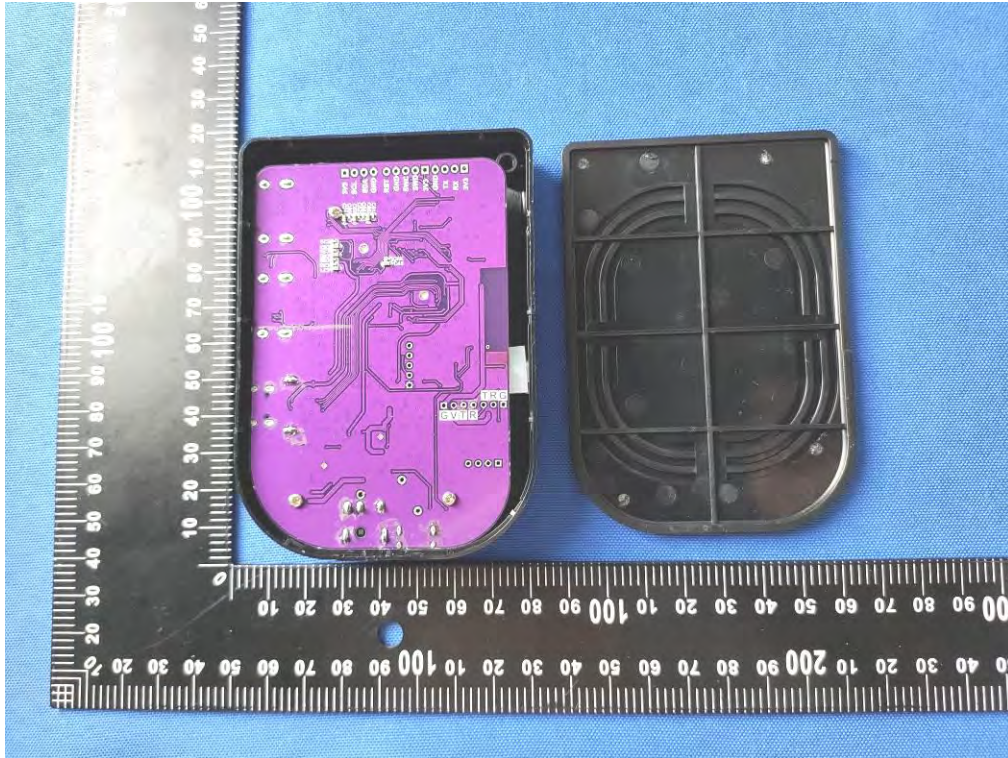

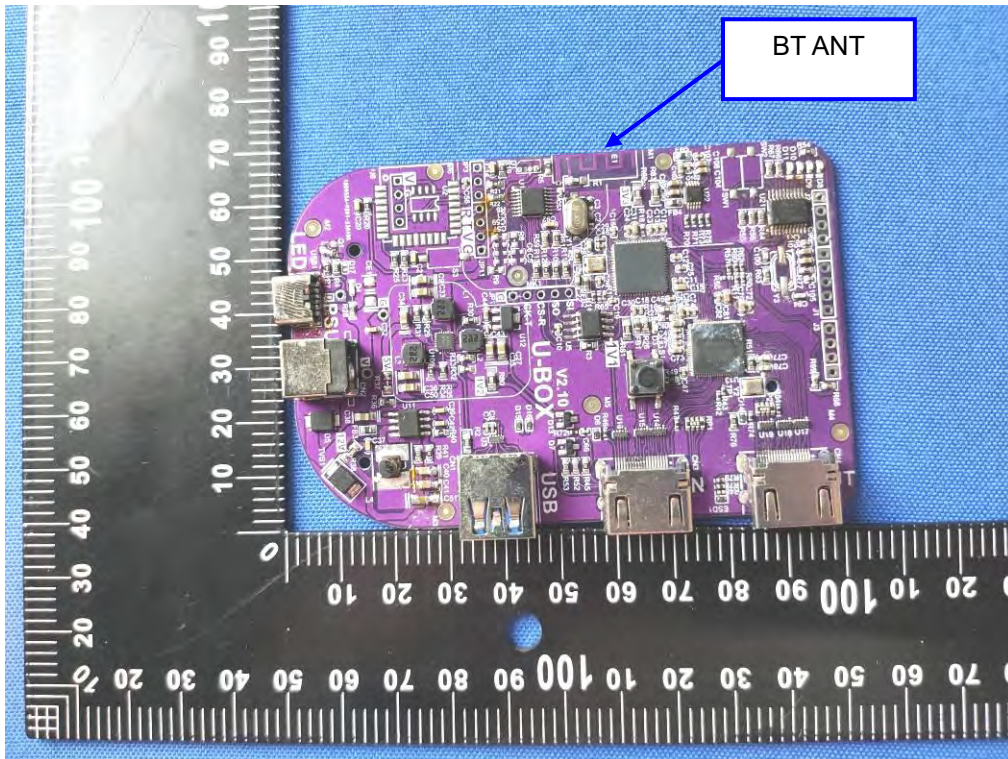
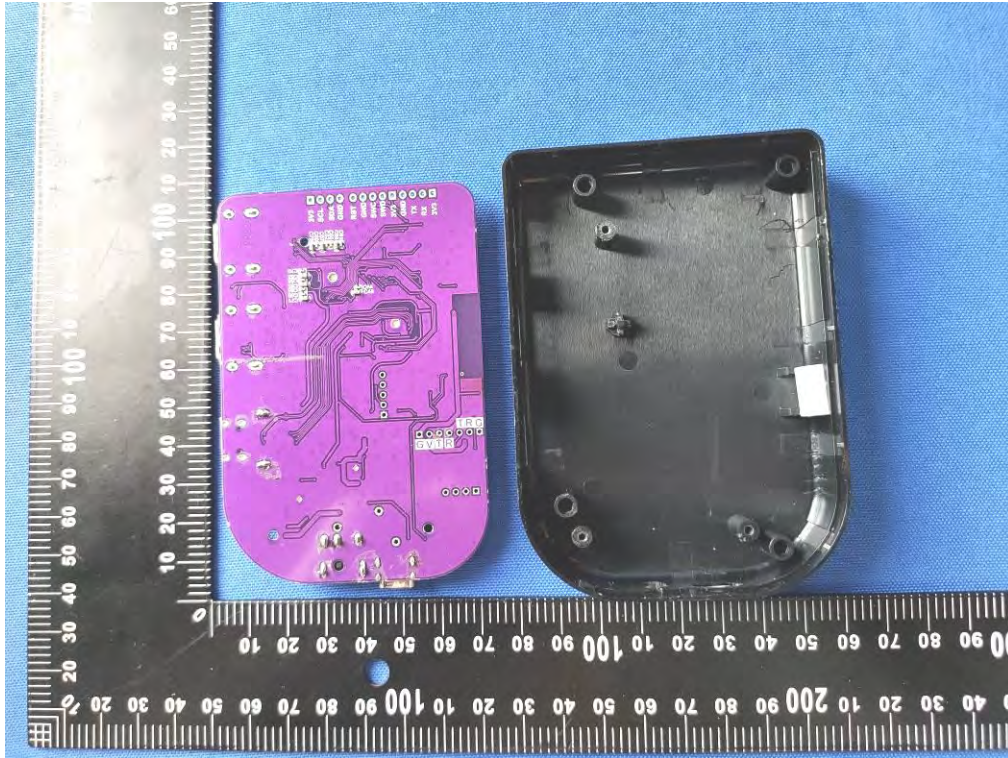

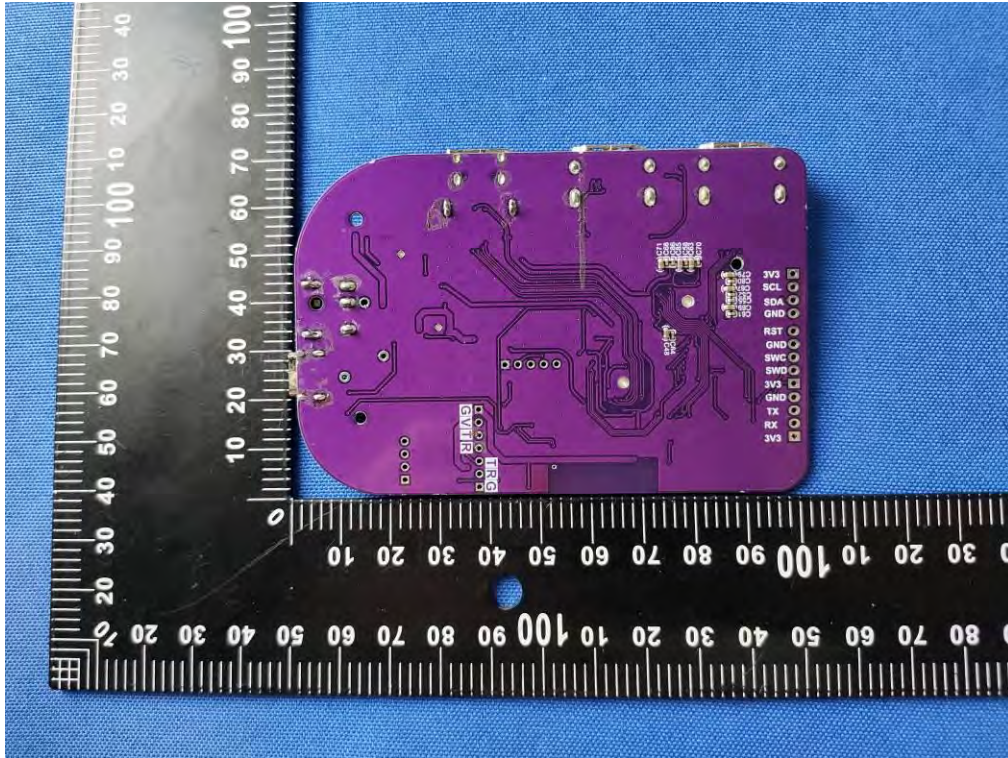

-----END OF REPORT-----