

Statement:

1. All book covers in this manual are for display purposes only and are not pre-installed books.
2. Some features may differ from those described in the manual; please refer to the actual product.

1. About Bigme

The founder and core team of Bigme have been engaged in the research and development of e-ink readers since 2008. Over the past 16 years, they have accumulated rich R&D and product experience, with a total shipment of over 8 million units. The products are sold to more than 100 countries, and there are more than 100 offline experience stores in China. The Bigme team pays great attention to the user experience and after-sales service of the products.

2. Safety Guide

Please read the following safety guidelines before use. If you encounter any technical difficulties, please contact your Bigme retailer, or call the national customer service number 400-0188-938, or send an email to the official email address vip@bigme.vip for assistance.

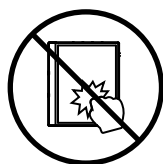

Screen Protection

The E-ink screen is fragile and easily damaged. Do not directly hit, squeeze, press the screen, or drop it from a height onto a hard surface. If the display screen is broken, stop using it and contact the official or other qualified professionals for replacement. Do not disassemble and replace it yourself.

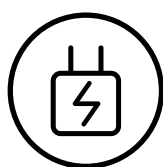

Qualified Accessories

Only batteries, chargers, and other accessories that meet the safety standards of this device are allowed. Please refer to the product configuration parameters. You will bear the damage caused by the use of incompatible accessories.



Keep Away from Liquids

This device is not waterproof. Do not expose the device to a humid

environment, do not use the product in the rain, and keep it away from any corrosive liquids.



Do Not Disassemble

The battery of this device cannot be replaced. Do not disassemble it yourself to avoid structural or screen damage.

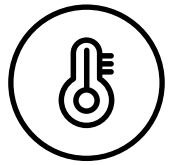

Operating Environment

The allowable operating temperature range of this device is 0°C-50°C.

3. Product View

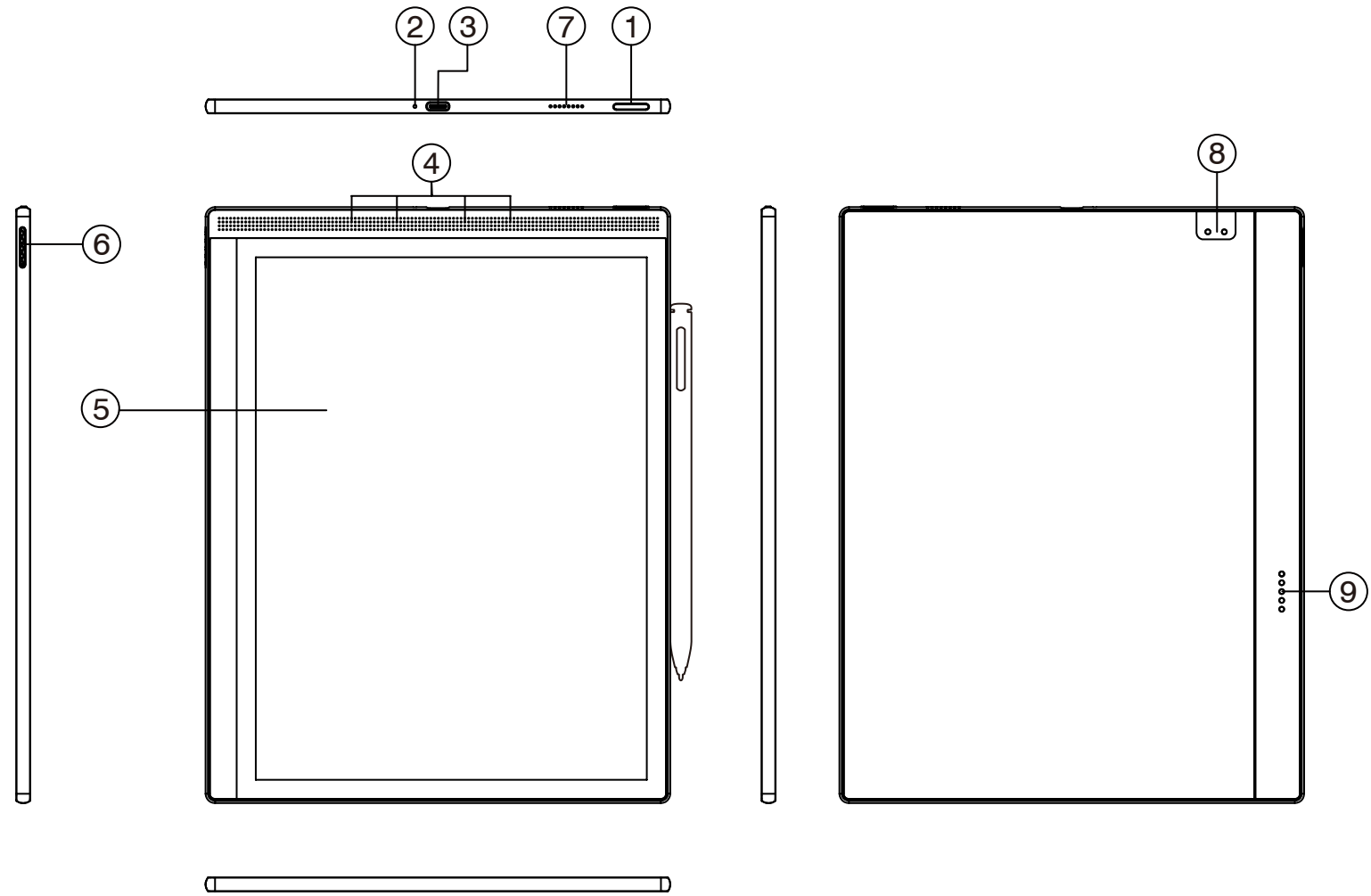

1. Power key/fingerprint key

3. Type-C interface

5. Handwritten ink screen

7. Horn

9. Keyboard connection contacts

2. Indicator

4. Microphone

6. TF slot

8. Rear camera

Button Function Description

1.Power Button/Fingerprint Button:

- Press and hold the power button for 3 seconds to start the device.
- Press and hold the power button for 1 second, choose "Shut-down/Restart" in the menu to shutdown/restart the device.
- Press the power button and then release immediately, the device enters sleep mode.
- Press the power button and then release immediately, wake up the device from sleep mode.

2.Indicator Light:

- The indicator light is on, indicating that it is charging and not yet full.
- The indicator light is off, indicating that it is fully charged or the Type-C USB cable is not properly inserted.

3.Type-C Interface:

Connect the PC host and the device to transfer data through the Type-C data cable, or charge the device.

4.TF Card Slot:

- Used for TF card expansion, supports up to 1 TB expansion.

Product Specifications

Model	B1051C	B1051
Size	10.3 inch color e-ink screen	10.3 inch e-ink screen
Overall Size	184.4*236.5*5.5mm	184.4*236.5*5.5mm
Resolution	2480x1860 B/W 1240x930 COLOR	2480x1860
PPI	300PPI B/W 150PPI COLOR	300PPI
ChatGPT	Supported	Supported
CPU	8-core 2.4GHz	8-core 2.4GHz
RAM/ROM	6+128GB	6+128GB
Handwriting	Smart Pen	Smart Pen
Expansion	TF card slot (TF card supports up to 1TB expansion)	TF card slot (TF card supports up to 1TB expansion)
Microphone	Dual-microphone array	Dual-microphone array
Speaker	Supported	Supported
Wireless Connection	2.4G/5G WIFI Bluetooth	2.4G/5G WIFI Bluetooth
Camera	Supported	Supported
Fingerprint unlock	Supported	Supported
Front light	36 levels (cold and warm)	36 levels (cold and warm)
Voice transcription	Free	Free
Battery capacity	3700mAh	3700mAh
Operating system	Android 14 open system	Android 14 open system

4. Main Interface

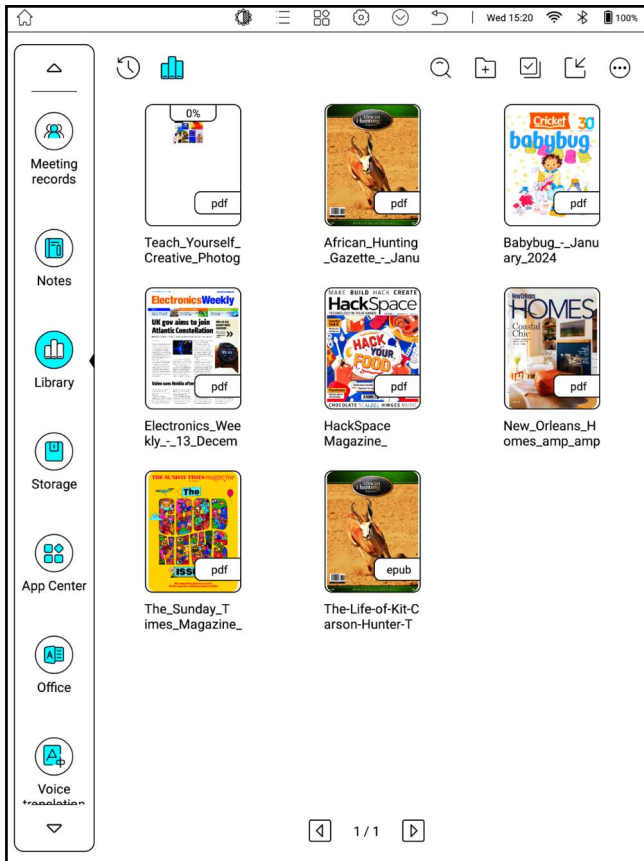

Office Mode

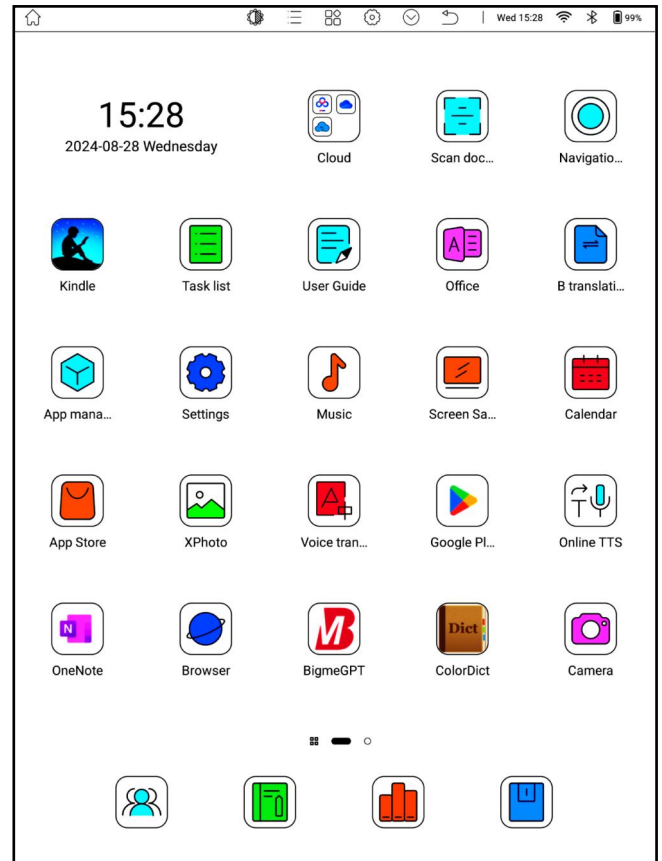

Tablet Mode

Theme Mode: You can click [Settings] > [Homepage Style] to switch between [Office Mode] and [Tablet Mode].

System Bar

1. Displays the current basic status of the device, including: time, WIFI status, Bluetooth, smart pen battery level, device battery level, etc.
2. Convenient operations, including returning to the homepage, application center, Elnk center, return, Eink Center, Application process, Settings, etc.
3. Pull down to bring out the status bar.

Menu Bar

1. Long press the application, drag to exchange application positions
2. Long press the menu bar or click [Settings - Menu Management] to enter the custom list; click [Switch] to set the shortcut applications in the menu bar.

Content Area

1. Under Office Mode: The content area displays the content interface of the selected application.
2. Under Tablet Mode: The content area displays the application desktop.

Status Bar

Home | Settings | 99%

Aug 28, 2024 15:29

XRZ_5G | Bluetooth

Eink center | Global hand... | Split screen | Process ma...

Screenshots | Miracast | Speed up | Record scre...

Touch | Power mana... | Settings | Screen rotati...

Lights out | Daytime | Night | Bedding | Other

0 | 30

More volume

13

Meeting records

Notes

Library

Storage

App Center

Office

Voice translation

0%

pdf

Teach_Yourself_Creative_Photog

ElectronicsWeekly

UK gov aims to join Atlantic Constellation

Valeo sues Nvidia after

pdf

Electronics_Weekly_-_13_Decem

The Sunday Times magazine

ISSI

pdf

The_Sunday_Times_Magazine_

Operation

1. Pull down at the top of the screen to display the [Status Bar].
2. Click on the blank space outside the [Status Bar] to retract the [Status Bar].

WIFI

1. Click to connect or disconnect WIFI.
2. Long press to enter the WIFI settings page and set up WIFI .

Bluetooth

1. Click to connect or disconnect Bluetooth.
2. Long press to enter the Bluetooth settings page and set up Bluetooth.

Shortcut Area

Used to display the convenient entrances of functions such as [E ink Center], [Global Handwriting], [Application Split Screen], [Process Management], [Super Screenshot], [One-Key Projection], [One-Key Acceleration], [Screen Recording], [Flight Mode], [Hand Touch], [Settings] and [Homepage].

Reading Light

Can adjust the cold and warm front light freely according to the usage environment and reading habits.

Volume

1. Freely adjust the sound volume or mute.
2. Can adjust the volume of media, calls, notifications, and alarms separately.

5. Meeting Record

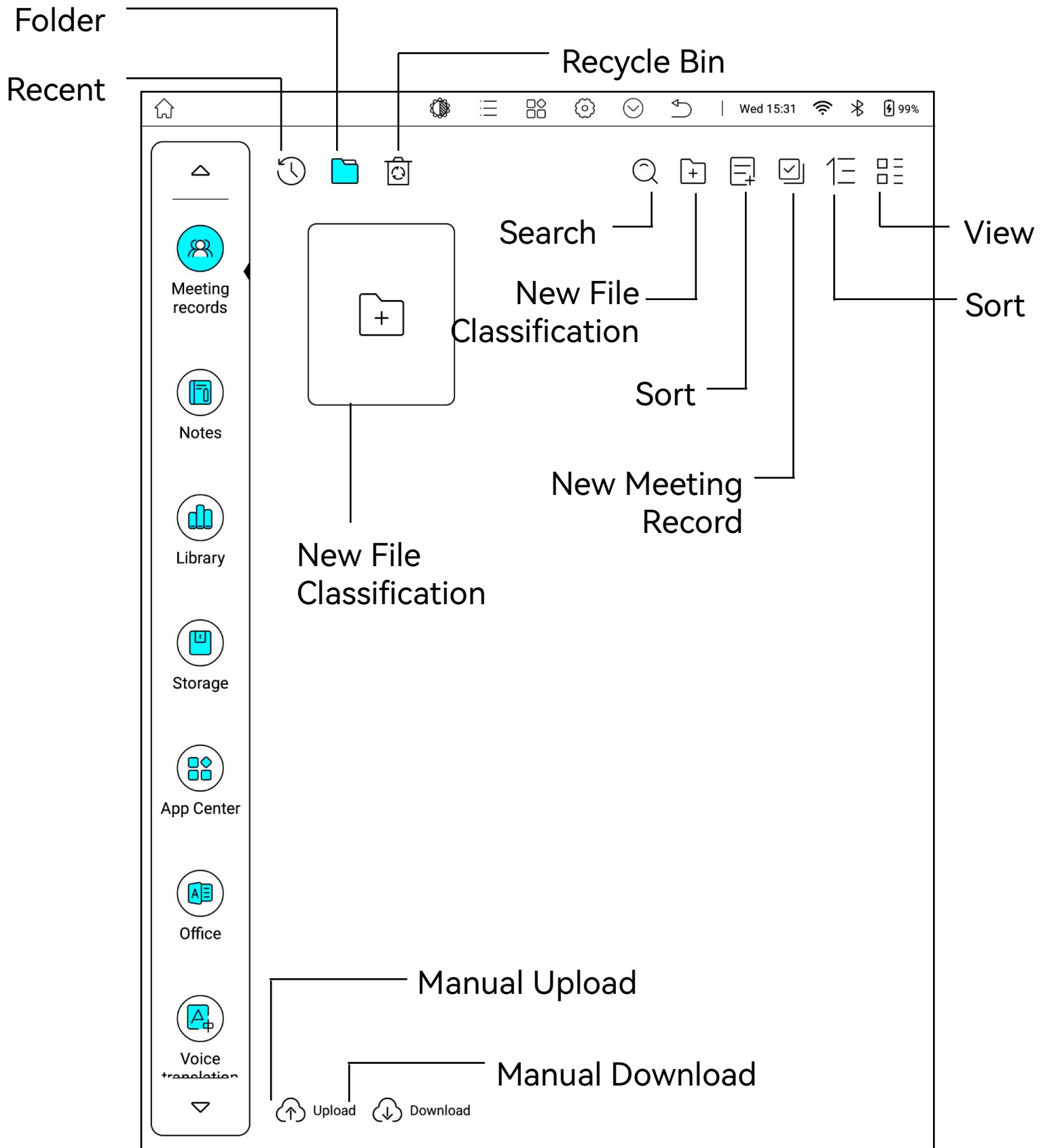

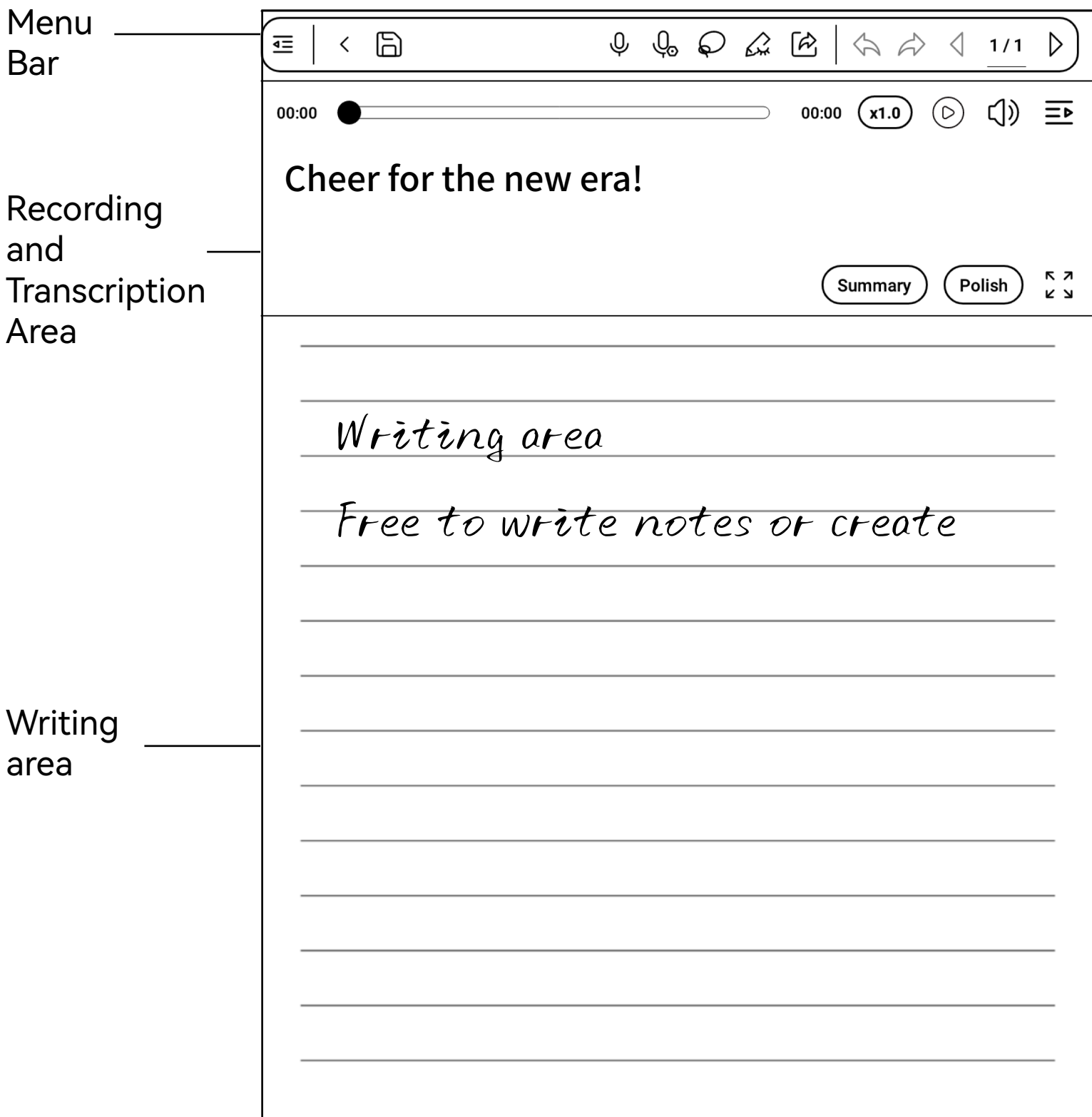

New Meeting Record - Basic Menu Bar

1. Save and Exit: You can save or delete meeting record notes.
2. Save: You can save notes.
3. Transcription of Recordings: You can record meetings and transcribe them into text.

4. Recording Settings: Easily switch between Chinese dialects and foreign languages; enable or disable the 'Multi-Person Mode' for recognizing multiple speakers during transcription; select professional vocabulary.
5. Toolbar: Display or hide the floating toolbar as needed; long-press on the floating toolbar to drag and reposition it.
6. Share & Export: Share meeting notes with others via QR codes, verification codes, etc.; export meeting notes into PDF or TXT files.
7. Undo: Go back to the previous action.
8. Redo: Proceed to the next action.
9. Previous Page: Flip to the previous page.
10. Next Page: Flip to the next page or add a new page.
11. Smart Summary: Extract key information from the meeting content.
12. Smart Organization: Optimize the content of the meeting minutes.

Creating New Meeting Records - Handwriting Area

1. Allows for freehand note-taking.
2. Allows for template switching.

Creating New Meeting Records - Recording Transcription Area

1. Allows for viewing of transcribed text content from voice recordings.
2. Allows for playback of recorded content.
3. Allows for speed adjustment during playback.
4. Allows for volume adjustment.
5. View Full Text: Allows for viewing of all transcribed content.
6. Playback Recording: Tapping on handwritten content plays corresponding voice recording; tapping on the recording playback progress bar jumps to corresponding transcribed content.
7. Transcription Content Editing: Tapping on transcribed content allows for manual modification or deletion of text.

Creating New Meeting Records - Translation

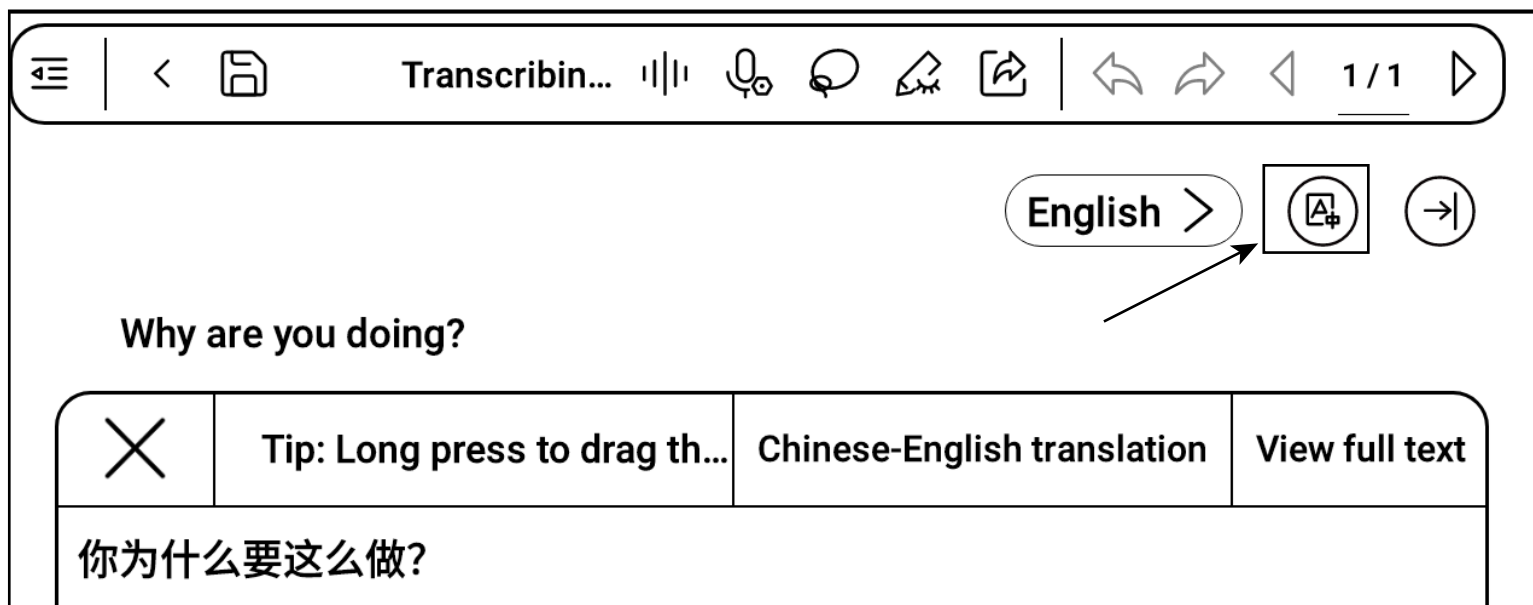

1. Click on [Recording Transcription] > [Start Translation] > [Select Language].
2. Start recording, and the system will automatically translate.
3. The translated results can be exported in the View Full Text section.

Creating New Meeting Records - Pen Type and Eraser Selection

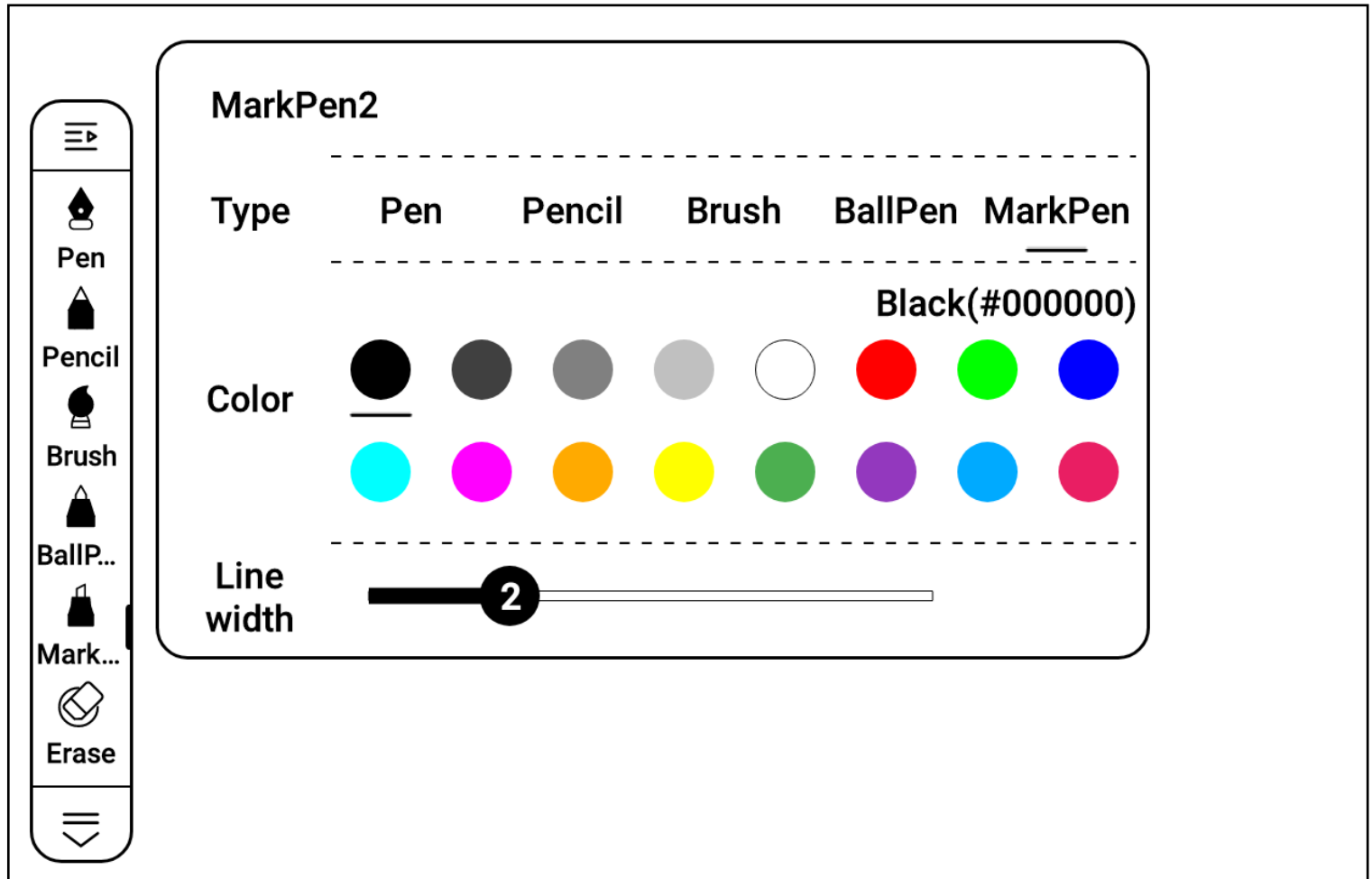

1. Toolbar: Allows for the display or hiding of the toolbar window.
2. Clicking on the pen type in the floating window, such as [Highlighter], allows for adjustment of the color and thickness of the pen stroke.
3. Eraser: Allows for selection of erasure methods such as track erasure, range erasure, or full erasure.
4. Insert: text, pictures, pages, templates, etc. can be inserted.
5. Delete this page: Delete the page that currently being edited.

Managing Meeting Records

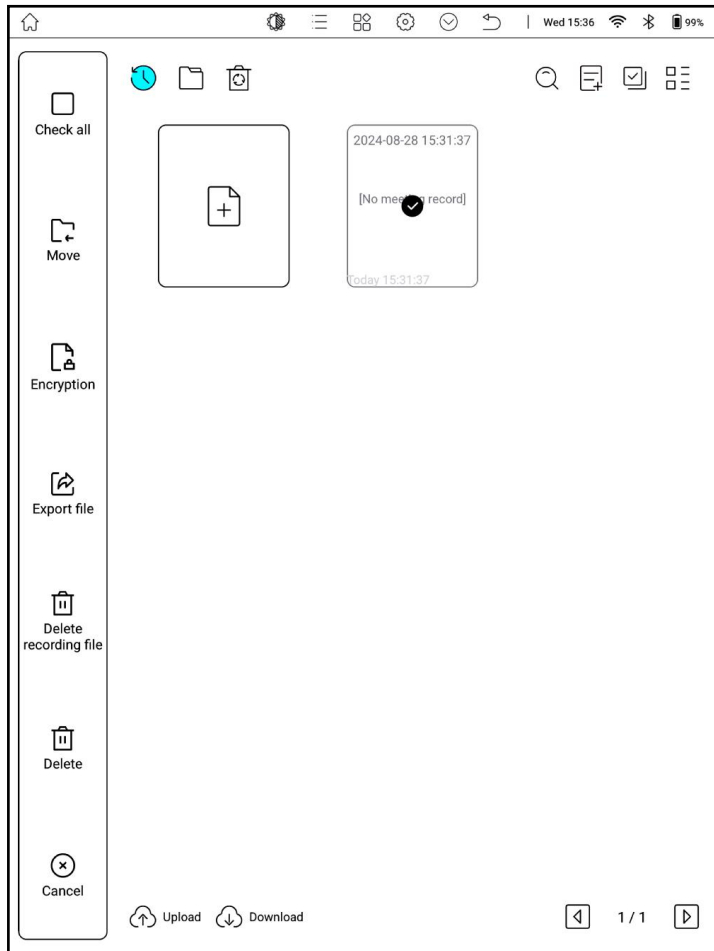

Multi-select

1. Click (multi-select) to perform operations such as selecting all, moving, encrypting, exporting files, deleting recording files, and deleting the meeting record documents.

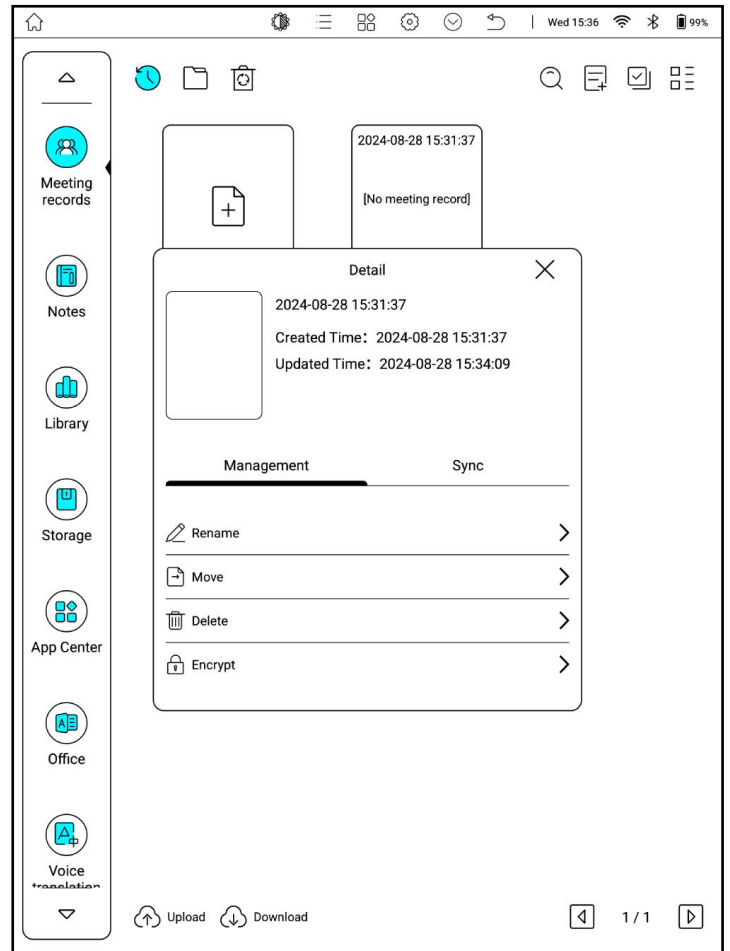

Long Press

2. Long press the meeting record document to rename, delete, move, encrypt notes, and synchronize to Onenote notes, Bigme Cloud, Baidu Cloud Disk, etc.

6. Notes

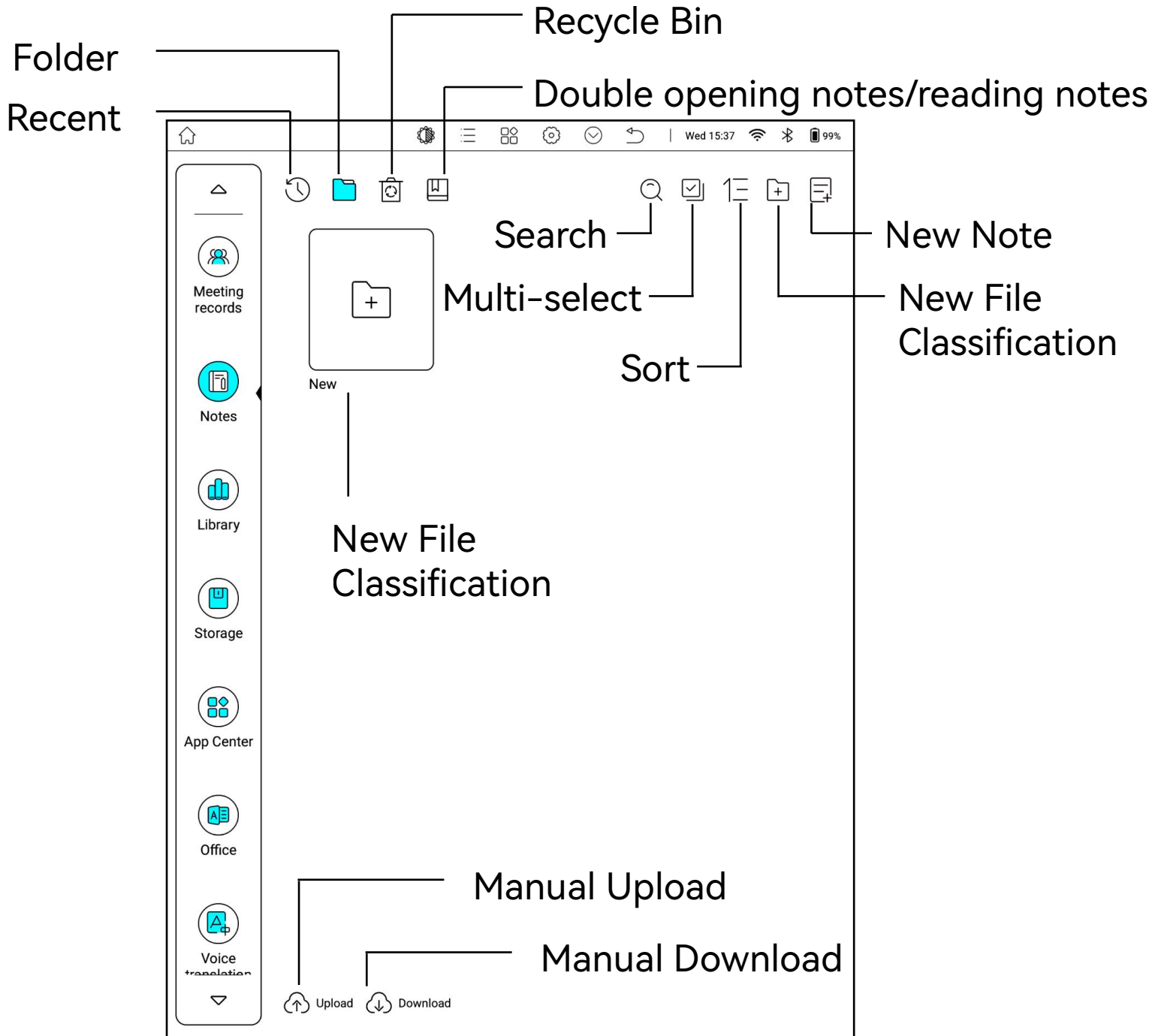

Menu Bar

The image shows a digital drawing application interface. At the top is a **Menu Bar** with icons for file operations (back, save, home, zoom, pan, copy, paste) and navigation (undo, redo, page 1/1). Below the menu bar is a vertical **Writing area** toolbar containing icons for Pen, Pencil, Brush, BallP..., Mark..., Erase, Page+, Page-, Tem..., Shap..., Filling, OCR, Insert, Gest..., and More. The main workspace features a settings panel for the selected tool, **MarkPen2**. This panel includes a **Type** selector with options Pen, Pencil, Brush, BallPen, and MarkPen (the last is selected). The **Color** section shows a grid of color swatches, with **Black(#000000)** selected. The **Line width** is set to 2, indicated by a slider.

Below the settings panel is a detailed black and white line drawing of a dog, possibly a pug, wearing a hoodie with a fur-lined hood and a drawstring. The drawing is composed of numerous fine lines and hatching to create texture and shading.

Writing area

Creating New Notes – Basic Menu Bar

1. Save and Exit: You can save or delete meeting record notes.
2. Save: You can save notes.
3. Layers: You can add, delete, hide, and lock layers.
4. Canvas: You can change the size of the canvas.
5. Lasso: You can move, copy, cut, delete, and perform OCR recognition on handwritten content.
6. Zoom: You can adjust the display size of the notes.
7. Toolbar: Allows for the display or hiding of the floating toolbar; long press on the floating toolbar to move its position.
8. Sharing and Exporting: Allows for sharing of meeting records to others through QR code, verification code, etc. Also allows for exporting of meeting records as PDF files or TXT files.
9. Undo: Returns to the previous operation.
10. Redo: Proceeds to the next operation.
11. Previous Page: Turns to the previous page.
12. Next Page: Turns to the next page or adds a new page.

Creating New Notes - Floating Toolbar and Handwriting Area

1. Toolbar: Allows for the display or hiding of the toolbar window.
2. Clicking on the pen type in the floating window, such as [Highlighter], allows for adjustment of the color and thickness of the pen stroke.
3. Eraser: Allows for selection of erasure methods such as track erasure, range erasure, or full erasure.
4. Insert: text, pictures, pages, templates, etc. can be inserted.
5. Delete this page: Delete the page that currently being edited.

Managing Notes

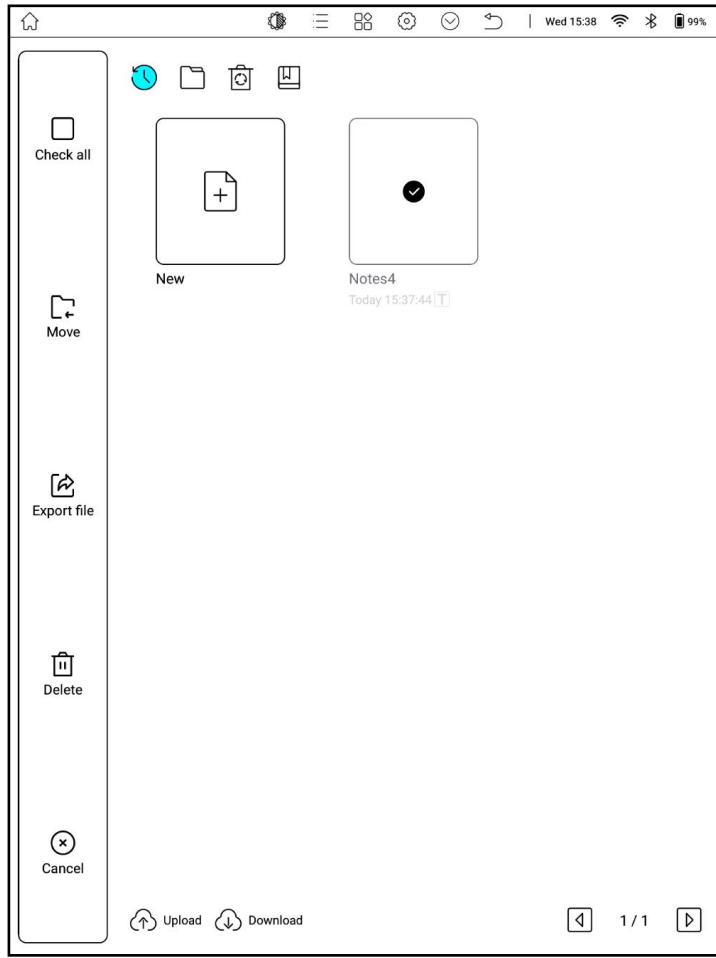

Multi-select

1. Click (multi-select), you can select all, move, export files, and delete the documents.

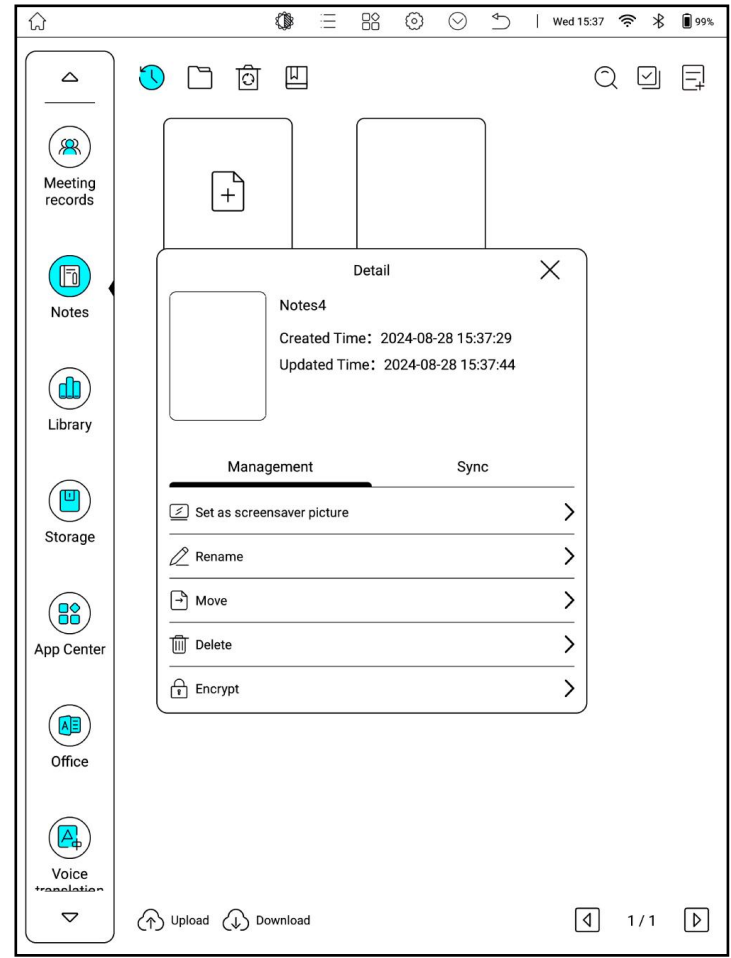

Long Press

2. Long press the document that on Notes, you can set it as a screen saver image, move, rename, delete, encrypt notes, and sync to Onenote notes, Bigme Cloud, Baidu Cloud Disk, etc.

7. Bookshelf

Bookshelf

Recent

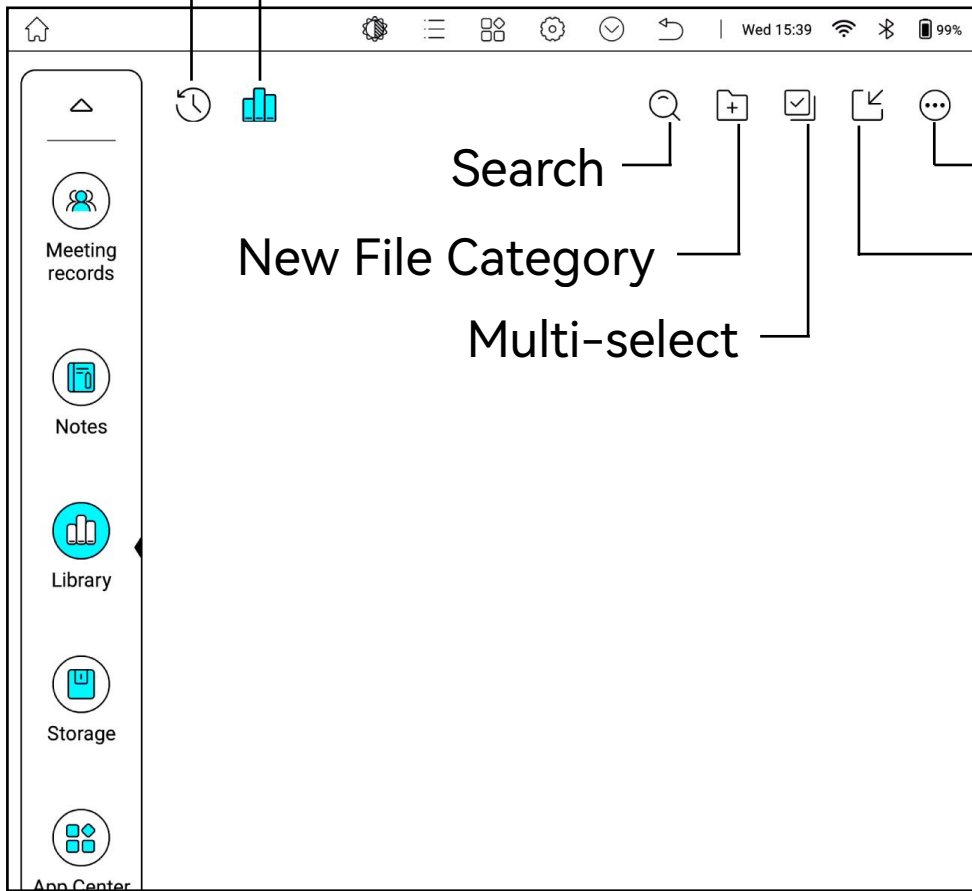

Search

New File Category

Multi-select

More operations

WiFi Import/
Local Import

Additional Operations:

1. You can reorder books by filename, creation time, and update time.
2. You can freely switch the page display style between grid and list.

Manage Books

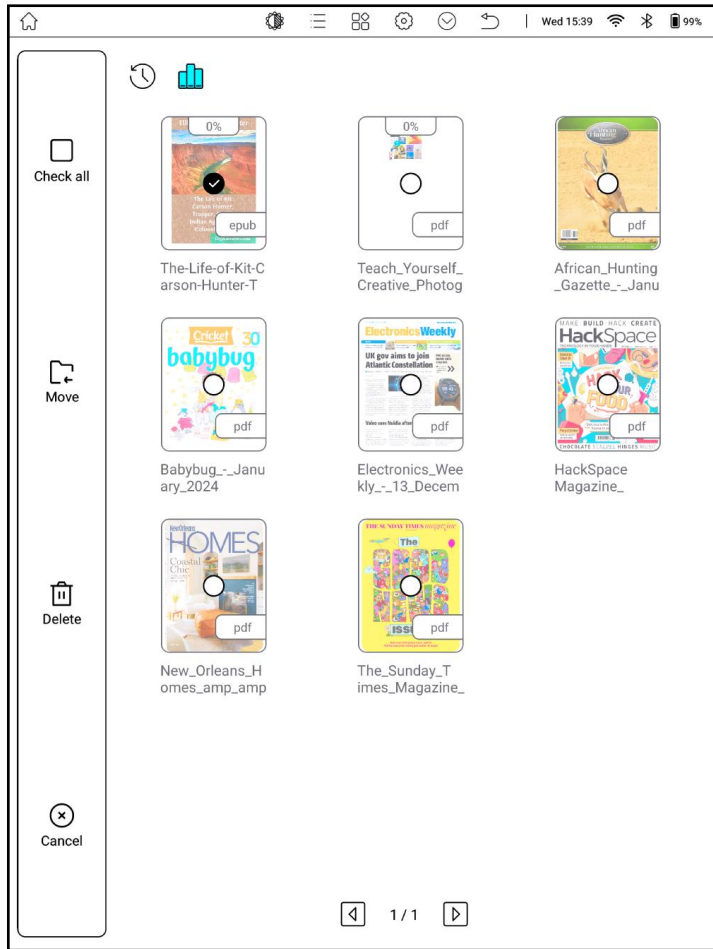

Multiple Selection



Long Press

1. Click on "Multiple Selection" to select all and delete book documents.
2. Long press on the book document to upload, move, rename, delete, share QR code, and other sharing operations.

Reading

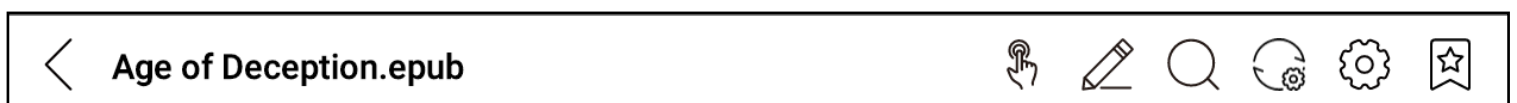

1. Return: Exit reading.
2. Touch: Click to turn on or off touch.

3. Handwriting Pen: Click to show or hide the type of pen and eraser window; adjust the color and thickness of the pen stroke; or choose an eraser to erase traces, erase range, erase all, etc.
4. Search: Enter keywords to search.
5. Refresh Settings: Allows toggling between refresh modes, such as Default (Normal), Magazine (HD 256), Comic (Regal), Video (Turbo), and Custom.
6. Basic Settings: Enables customization of the long-press menu and switching of the dictionary, along with other settings.
7. Bookmark: Bookmark the current reading page.

Table of Contents

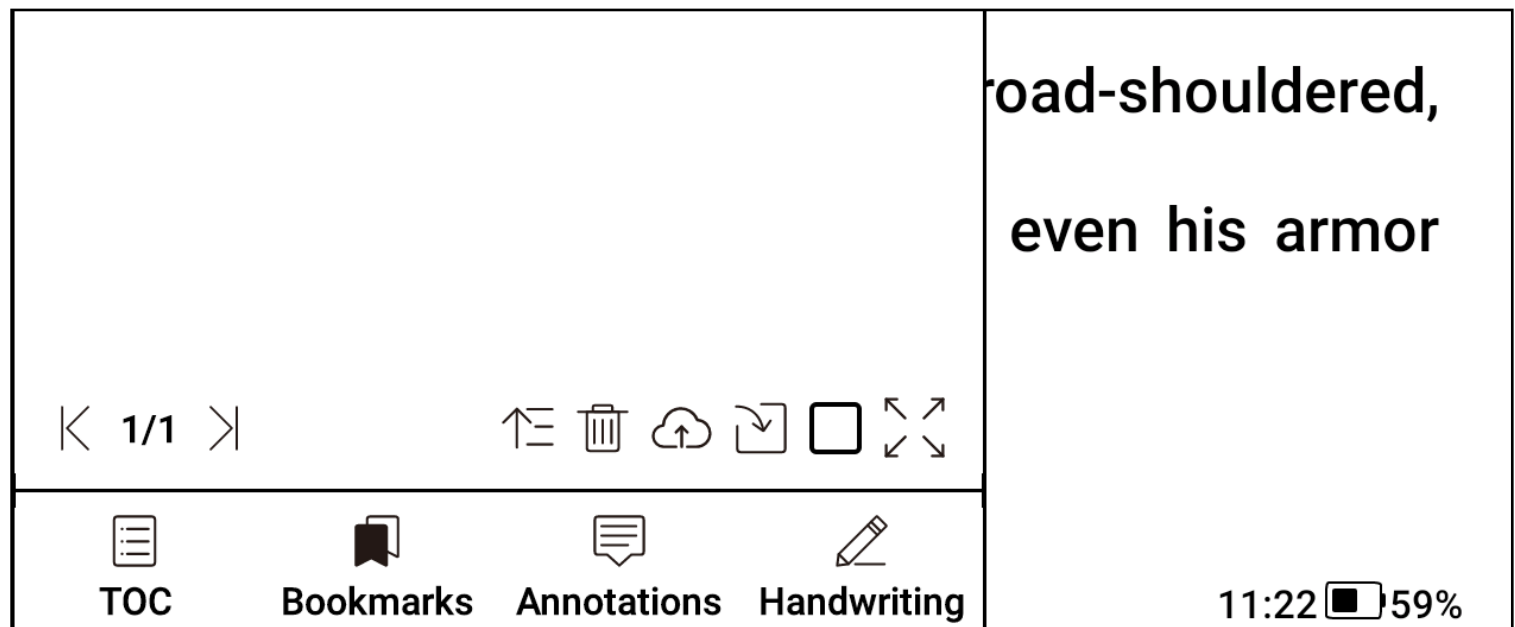

1. View the book's table of contents.
2. View the book reading's bookmark notes.
3. View the book reading's annotation notes.

4. View the book reading's handwritten notes.

5. You can sort, delete, upload to the cloud, export, and select all notes.

6. You can display the window in full screen.

Progress

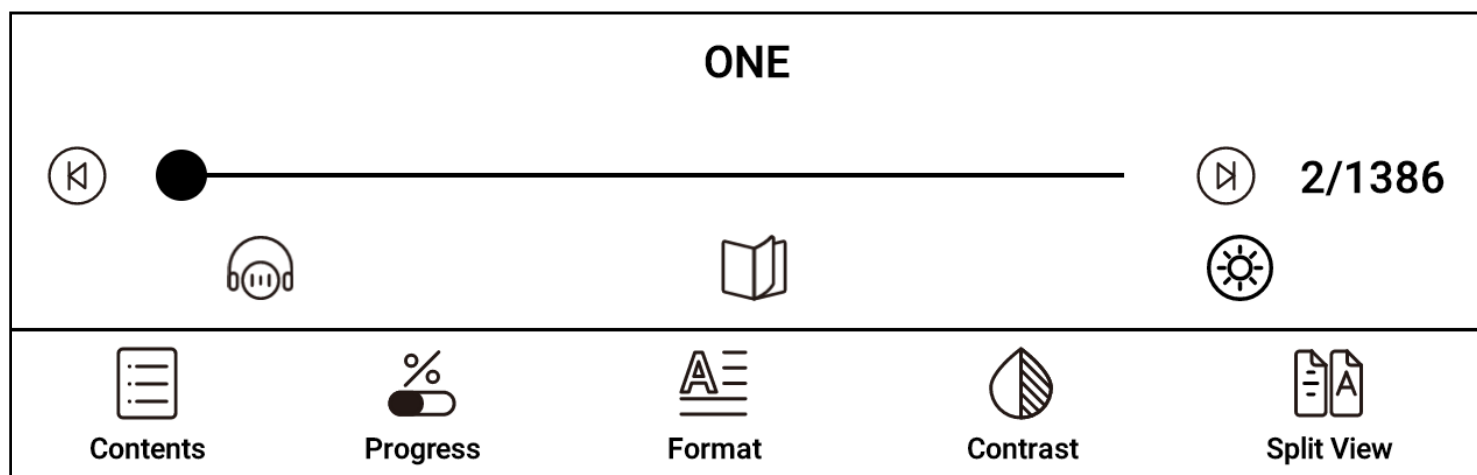

1. Previous Chapter: Go back to the previous chapter of the book.

2. Next Chapter: Go to the next chapter of the book.

3. Listen to the book: Set a timer, adjust the volume and playback speed.

4. Automatic page turning: Set a timer, adjust the automatic page turning interval and adjust the total number of automatic page turns.

5. Night/Day Mode: Freely switch between night or day mode according to your own reading habits.

Typesetting

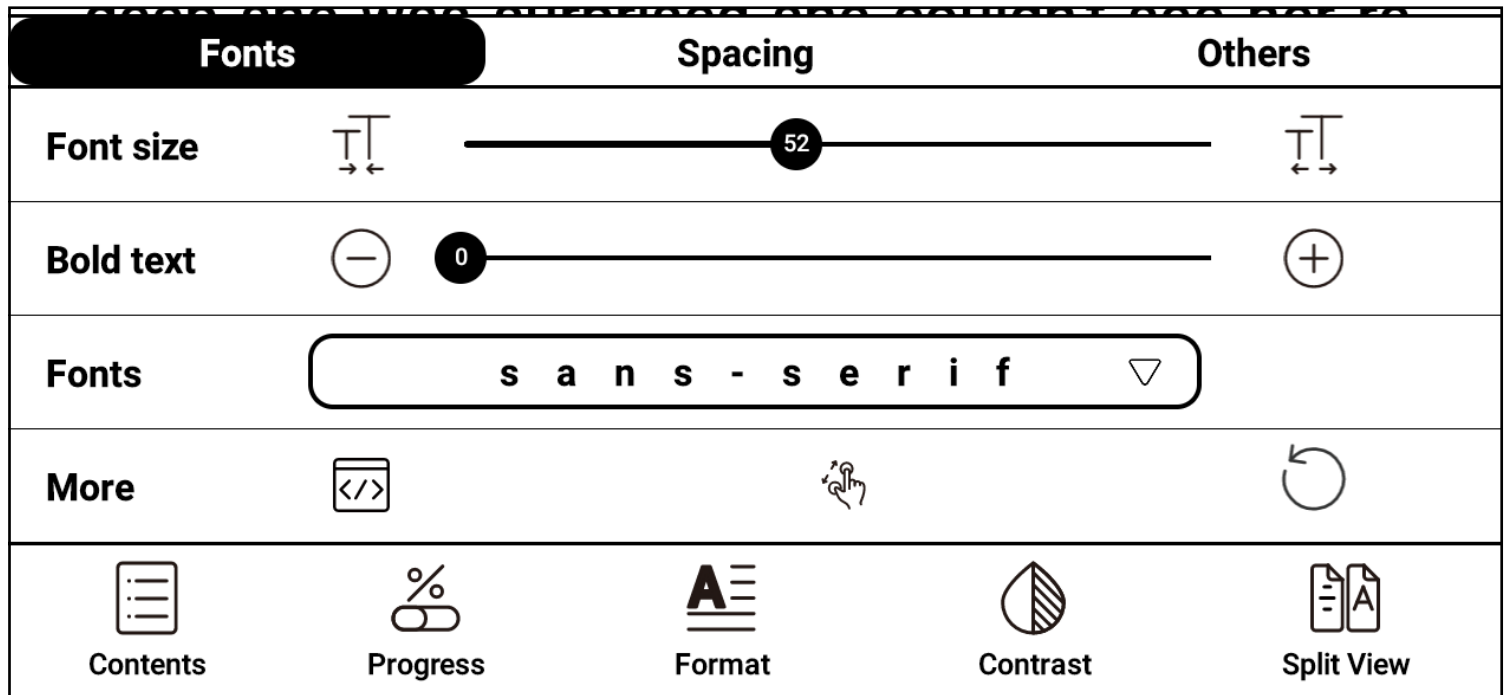

1. Font: Adjust the text size, font thickness, and change the font; change the encoding, turn on or off two-finger zoom and one-click restore default settings; support custom fonts, put ttf format fonts in the xReader/fonts directory.

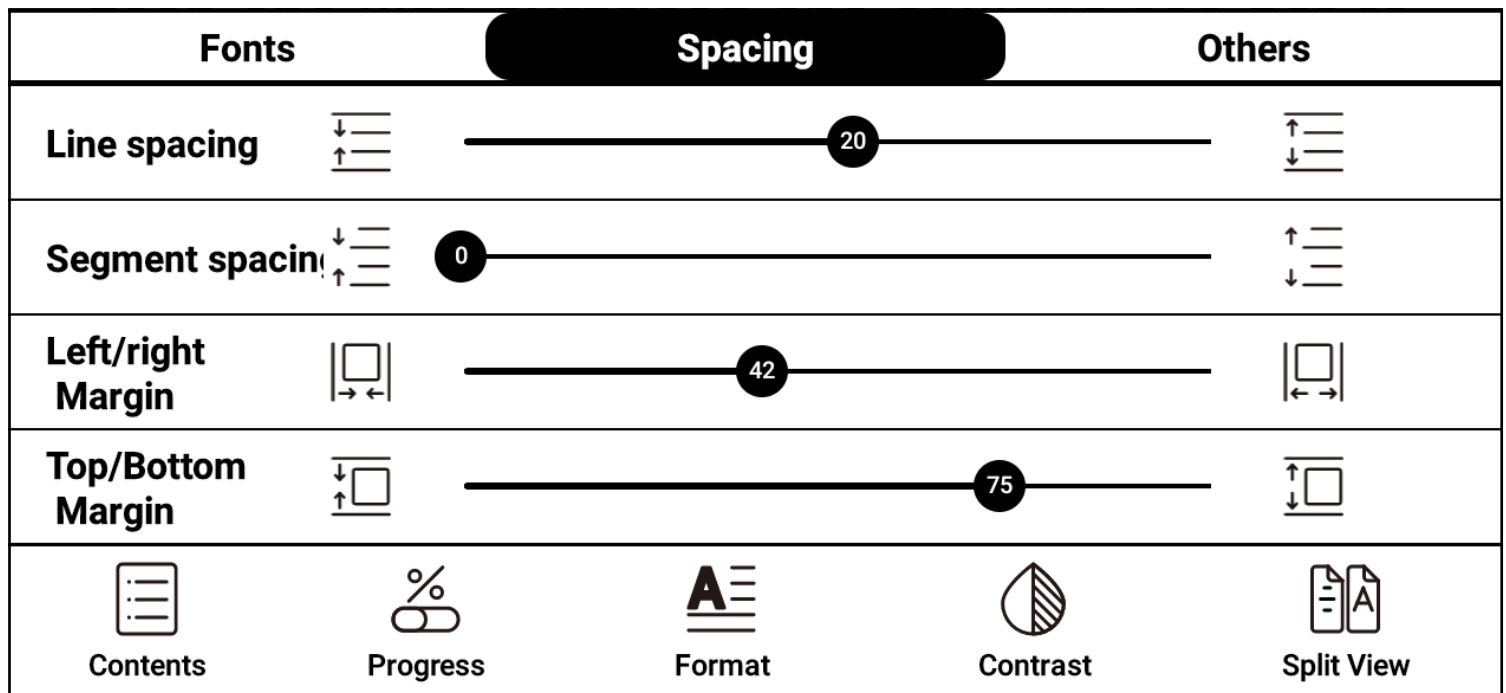

2. Style: Adjust the line spacing, paragraph spacing, left and right spacing, and top and bottom spacing of the article.

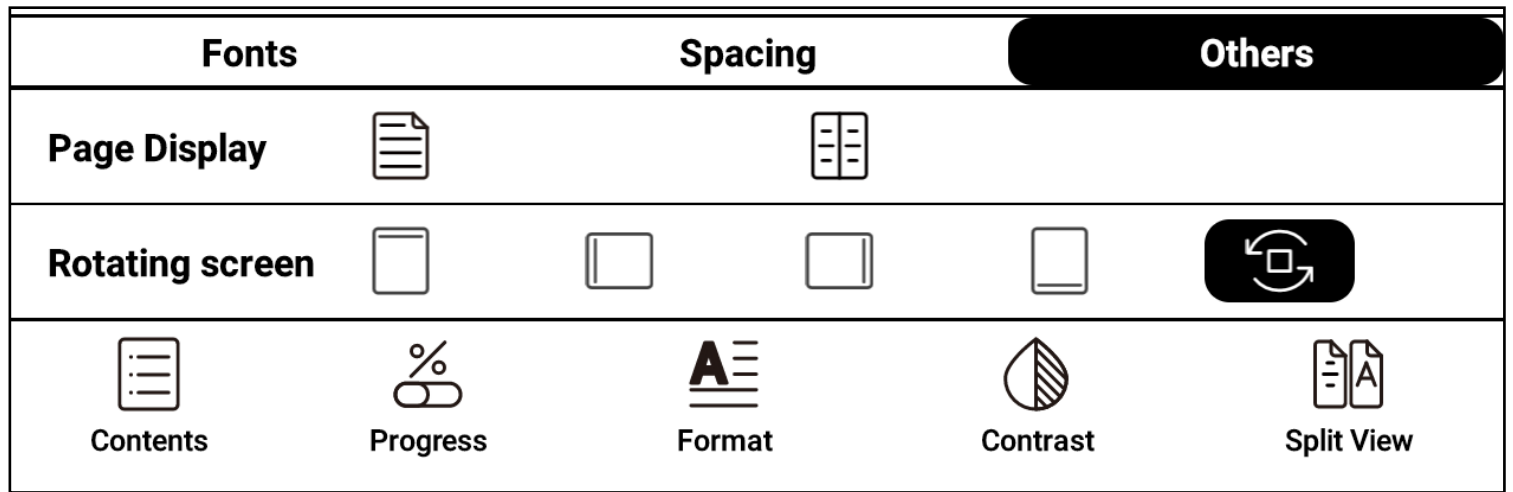

3. Other: Convert between simplified, traditional and default fonts; set double-page or single-page reading; adjust the screen orientation.

Contrast

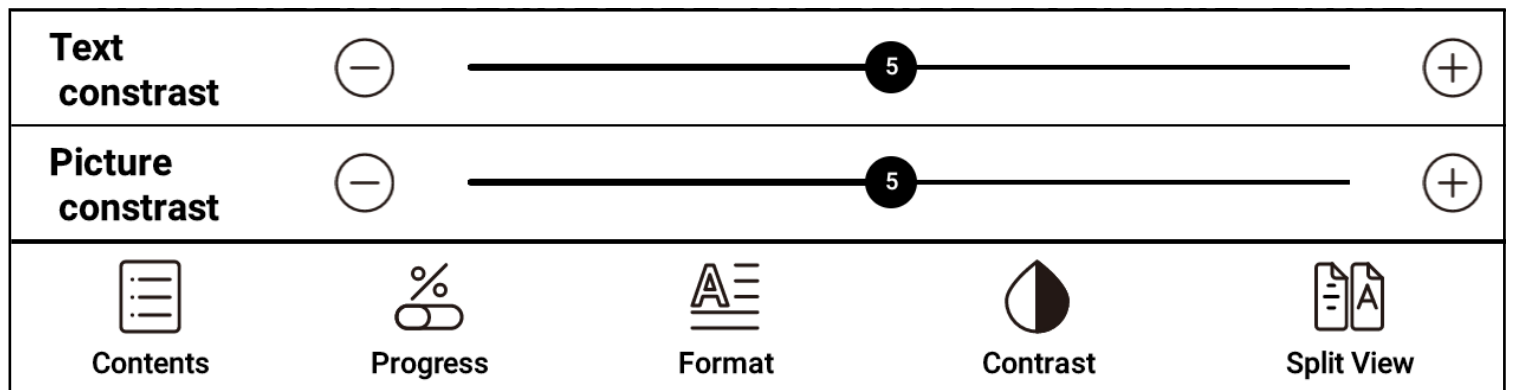

1. Text Contrast: Adjust the clarity of the text.

2. Image Contrast: Adjust the clarity of the image.

Double Open

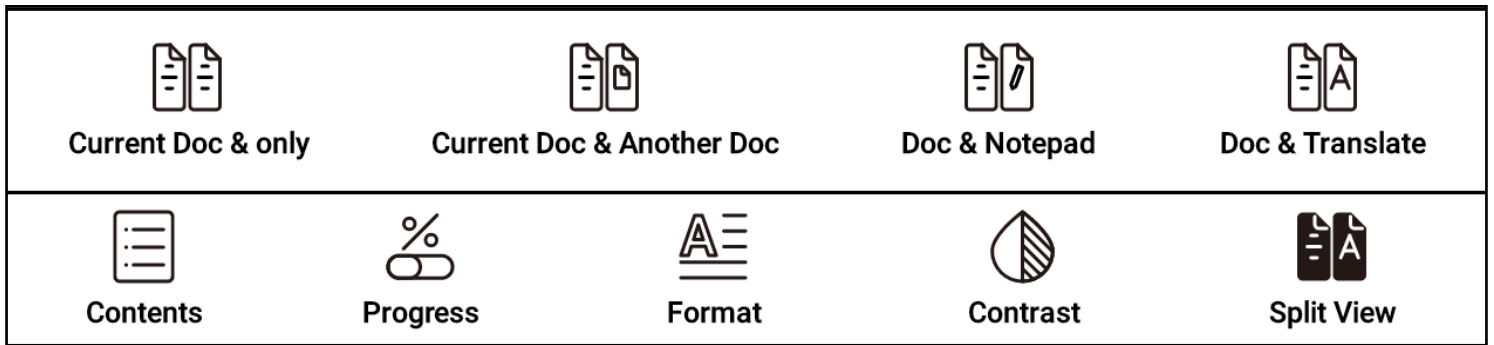

1. Double open the current document: Double open the currently reading document for split-screen browsing.
2. Double open different documents: Double open split screen, open two different documents for reading at the same time.
3. Double open notes: Double open split screen, make records while browsing the document.
4. Double open translation: Double open split screen, intelligently translate the document content while browsing the document.

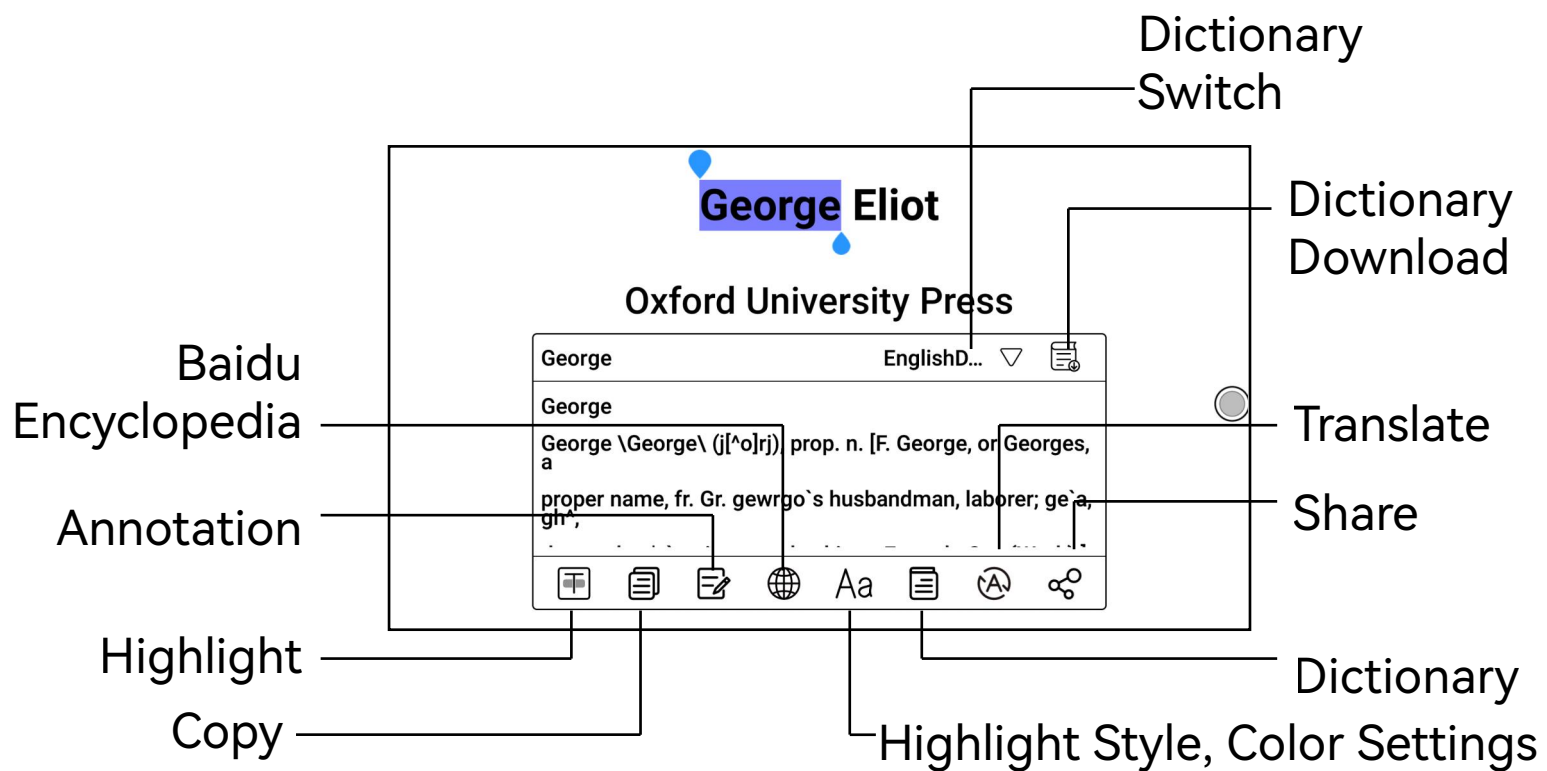

Long Press - Word Selection Menu

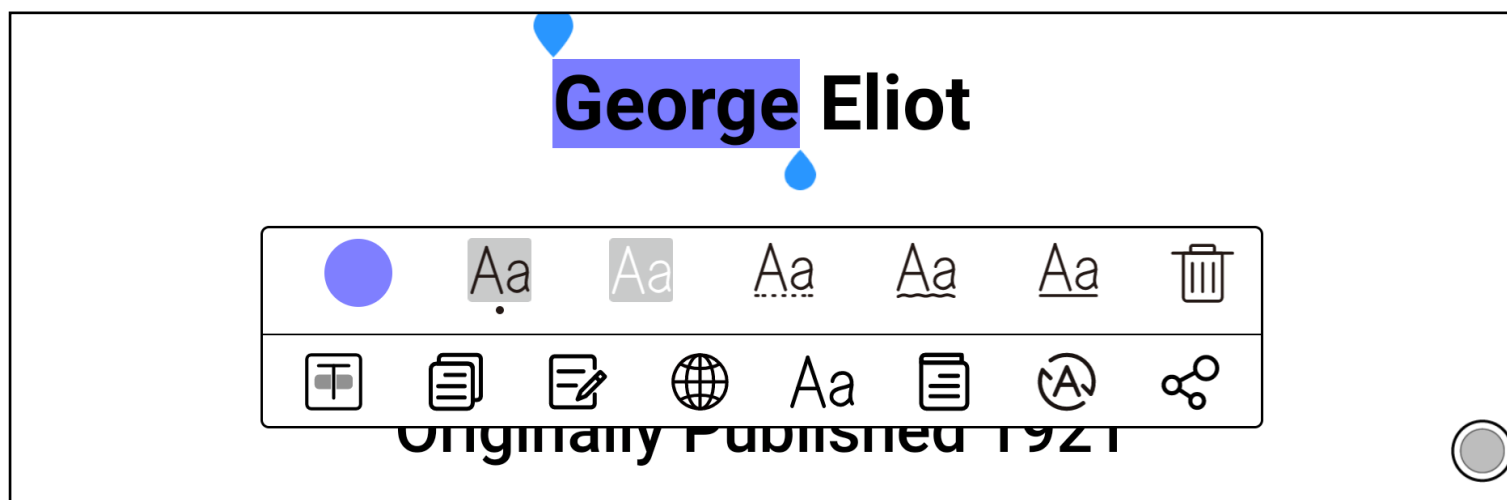

1. You can call the dictionary to query the text.
2. Support multiple dictionary switching, you can select the required dictionary document from the drop-down menu.
3. This function requires dictionary document support. If no dictionary document is loaded, word queries cannot be made.
4. Click on a blank space to exit the dictionary query.

Long Press - Word Selection Menu







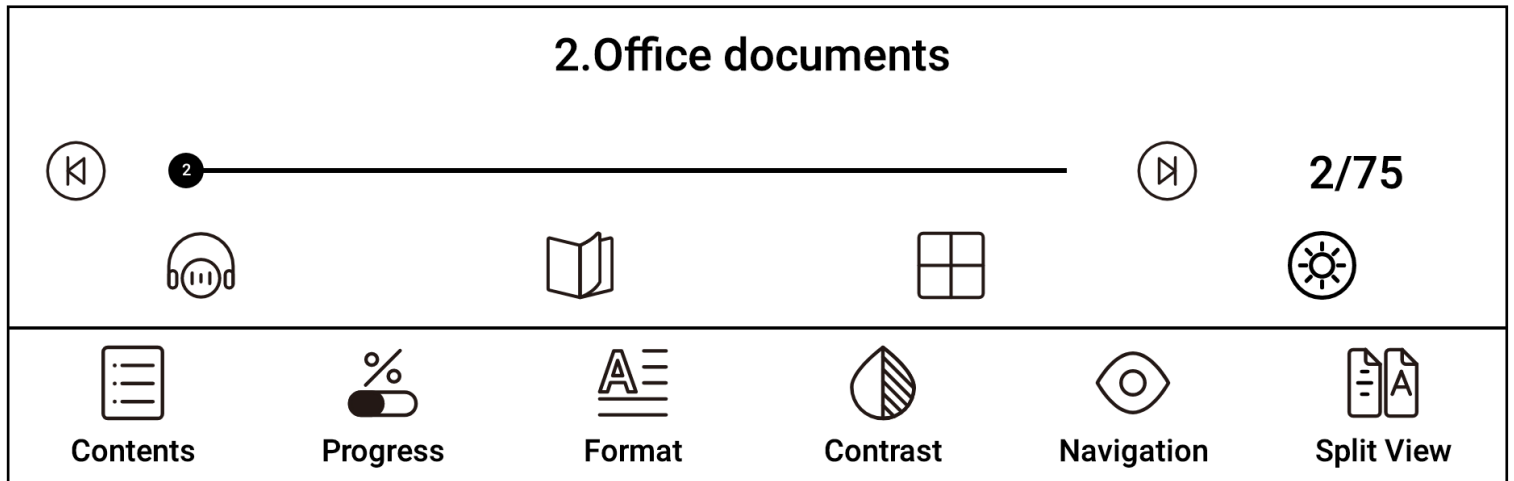



















1. Highlight Style Color Setting: Use the highlighter to long press the word and select the icon [**Aa**] in the pop-up menu. You can set the highlight style such as highlight, underline, wavy line, and also set the highlight color.
2. Set Highlight: Use the highlighter to long press the word and select the icon [] in the pop-up menu to highlight the selected content.
3. Delete Highlight: Click on the highlighted content with your hand and select the icon [**Aa** > ] in the pop-up menu to delete the highlight.
4. Click outside the word selection menu to directly exit the word selection menu.

Progress - PDF



1. Previous Chapter: Go back to the previous chapter of the book.
2. Next Chapter: Go to the next chapter of the book.
3. Listen to the book: Set a timer, adjust the volume and playback speed.
4. Automatic page turning: Set a timer, adjust the automatic page turning interval and adjust the total number of automatic page turns.
5. Quick Preview: Display multiple pages of documents at the same time for quick preview, you can set single page, 4 grid, 9 grid, and 16 grid display.
6. Night/Day Mode: Freely switch between night or day mode according to your own reading habits.

Typesetting - PDF

Page Display					
Zoom					
Crop					
Rotation					
Leaving Blank Space					
					
Contents	Progress	Format	Contrast	Navigation	Split View

1. Pagination: Choose the left or right side as the starting page.
2. Zoom: Click to gradually enlarge or shrink; turn on or off two-finger zoom.
3. Crop: You can crop corners, top and bottom, left and right, all around, and custom cropping.
4. Rotate: You can set the rotation direction to default portrait, rotate 90°, rotate 180°, rotate 270° or rotate with the system direction .
5. Margin: When choosing left and right cropping, it is the default size of the blank area retained when cropping, which is a manual modification of the cropping edge.

Contrast - PDF

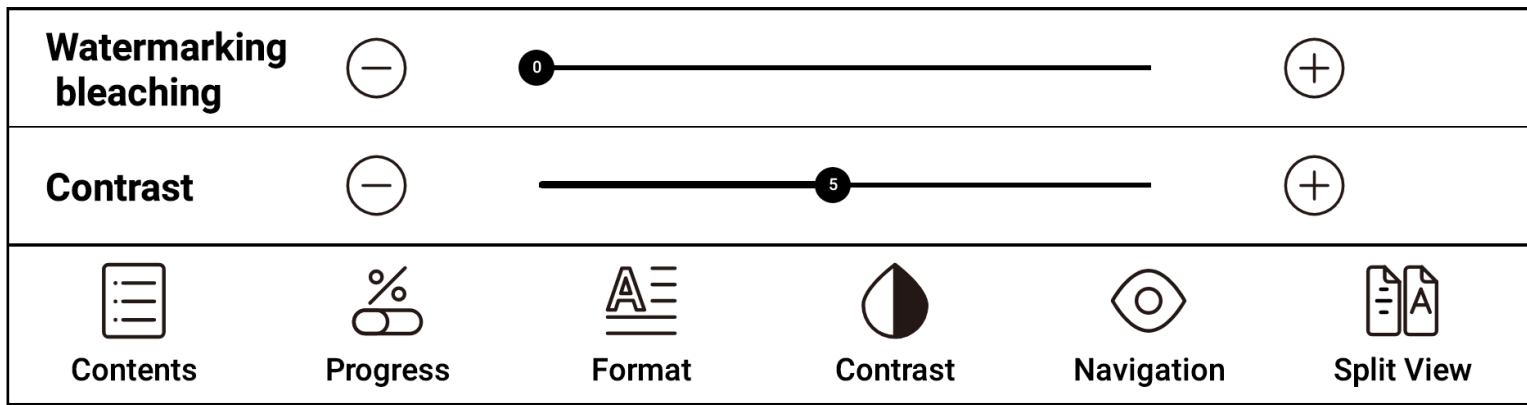

1. Watermark Bleaching: You can bleach and remove the watermark on the page.

2. Contrast: Adjust the clarity of the document content.

Browse - PDF

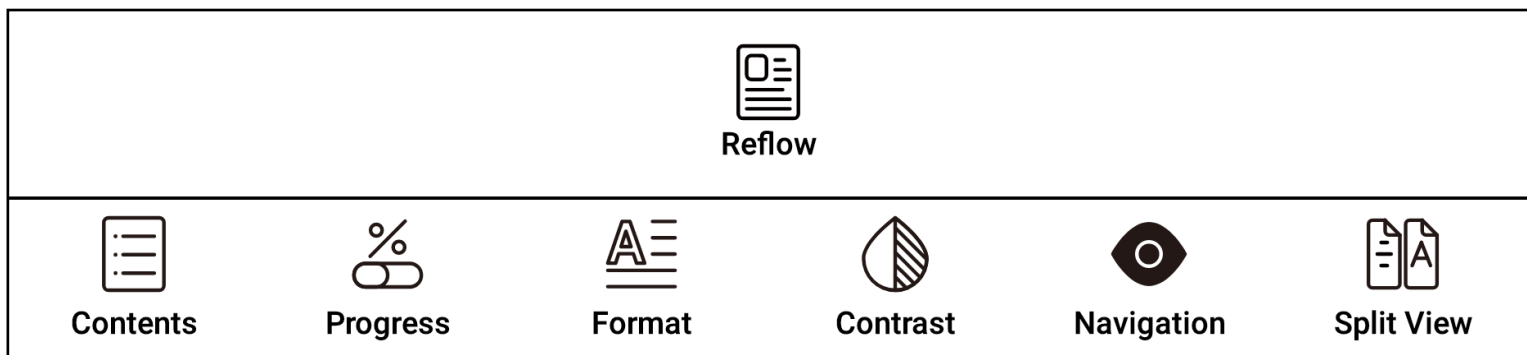

Reflow: Repaginate the document content.

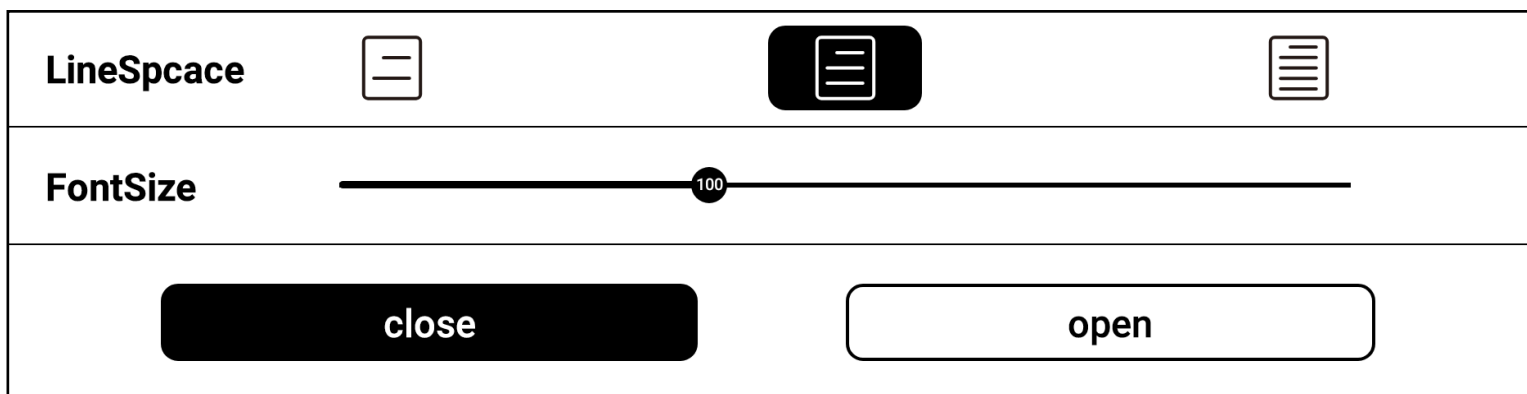

1. Line Spacing Format: Adjust the line spacing of the document's text content.

2. Font Size: Adjust the size of the document's text.

8. Office Documents

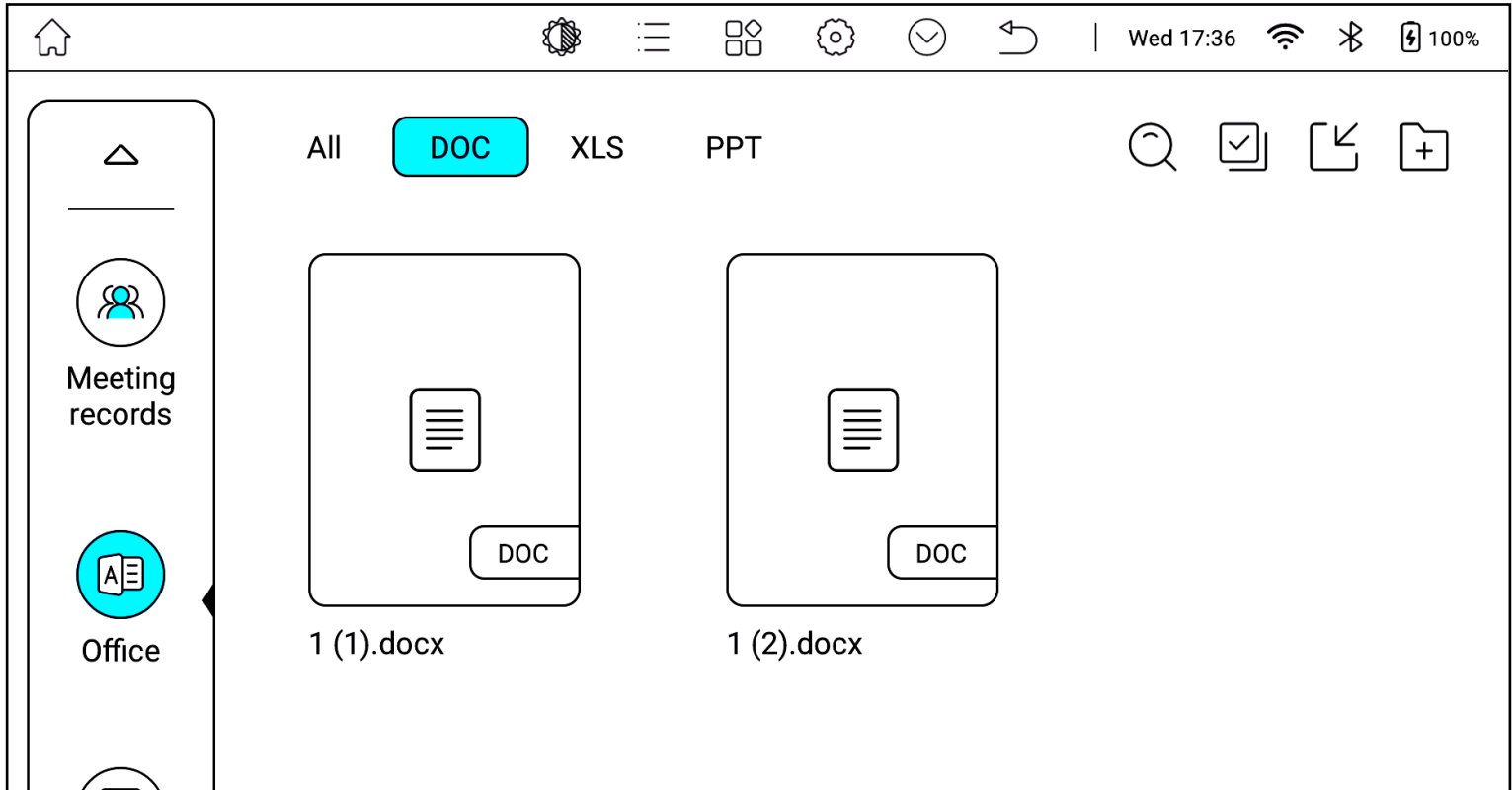

1. All: Display all Office documents.

2. Documents: Display doc, docx files.

3. Tables: Display xls, xlsx files.

4. Presentations: Display ppt, pptx files.

5. Search: Enter keywords to find files.

6. Multi-select: Select multiple files for actions like moving and deleting.

7. Import: Import from /internal storage/Office subfolders or /internal storage/Download folder.

8. Folder: Create new folders for file categorization.

9. Long press file: Upload, delete, rename, move, share via QR code and other sharing options (like Bluetooth, email).

9. Ai Assistant

Chat

<

Chat Composition AI Draw 

2023-11-28 16:22:28 Conversation New

(((Help me write a daily work report, focusing on UI design work content 



 **Subject: Daily Work Report - UI Design**

Date: [Date]

Dear [Supervisor/Team],

I am writing to provide a detailed summary of the UI design work I have accomplished today. Please find below a breakdown of the tasks I have completed:

- User Interface Prototyping:**
 - Created wireframes and prototypes for the new product feature in collaboration with the development team.
 - Incorporated feedback from stakeholders to fine-tune the user interface designs.
 - Explored various design concepts and layouts to ensure an intuitive and visually appealing interface.
- Graphic Design:**
 - Developed high-fidelity mockups for upcoming website enhancements, including landing pages and interactive elements.
 - Collaborated with the marketing team to design engaging visual assets for social media campaigns, ensuring brand consistency.
- Interaction Design:**
 - Conducted thorough research on user behaviors and preferences to inform optimal interaction patterns.
 - Implemented interactive elements, such as buttons, menus, tooltips, and animations, for enhanced user experience.
 - Worked closely with the development team to ensure seamless implementation of interactions within the interface.
- Visual Styling:**
 - Defined a comprehensive style guide for UI components, including typography choices, color schemes, and iconography.
 - Maintained consistency across all screens by adhering to established design standards throughout various product modules.
- User Testing and Feedback Integration:**
 - Conducted usability testing sessions with a group of selected users to gather feedback on specific UI features.
 - Analyzed feedback data and implemented necessary design iterations based on user insights garnered from these sessions.

 What would you like to chat with me? 

1. Avatar: View ChatGPT's account and profile.
2. Conversations: View past chat history.
3. New: Create a new chat with a custom title.
4. Dialogue Box: Voice input, keyboard input, or handwriting input.

Composition

The screenshot shows the 'Composition' tab in the ChatGPT interface. At the top, there are three tabs: 'Chat', 'Composition' (which is selected and highlighted in black), and 'AI Draw'. To the right of these tabs is a user profile icon. Below the tabs, there is an 'Export' button. The main section is titled 'Composition Theme' and contains a text input field with the word 'Sky' entered. To the right of this field is a 'Submit' button. Below the theme field is an 'Outline' section, which contains a list of three generated topics: '1. The Majesty of the Sky: Exploring its Wonders and Marvels', '2. The Significance of the Sky in Human Culture and Religion', and '3. Protecting the Skies: Environmental Concerns and Efforts for a Sustainable Future'. At the bottom of the interface is a large 'AI Generate' button.

1. Topic: Enter the title of the article you want to write.
2. Outline: AI generates a creative outline, which can be modified.
3. AI Generation: AI generates different content paragraphs.
4. Export: Export as TXT or PDF document.

AI Draw



Chat

Composition

AI Draw



Drawing description

I am an AI painter, I can generate pictures based on your description (it is recommended to use multiple specific keywords and phrases to describe)

0/300

You can describe the image features that need to be generated like this

Sweet, long hair, eyes

Natural scenery, mo...

可爱 神奇 幻想艺术, 金色

Lions, flowers, exqui...

Fantasy adventure...

鱼缸世界, 落英缤纷, 鱼...

Paper cutting craft, ...

cute, magical, fantasy...

The fish tank world, ...

Start creation

My creation



◀ 1 / 1 ▶

Painting Description: Enter keywords and adjectives related to the picture you want. The more detailed the description, the more accurate the picture will be.

10. Image Browser

Set Screensaver/Cancel Screensaver

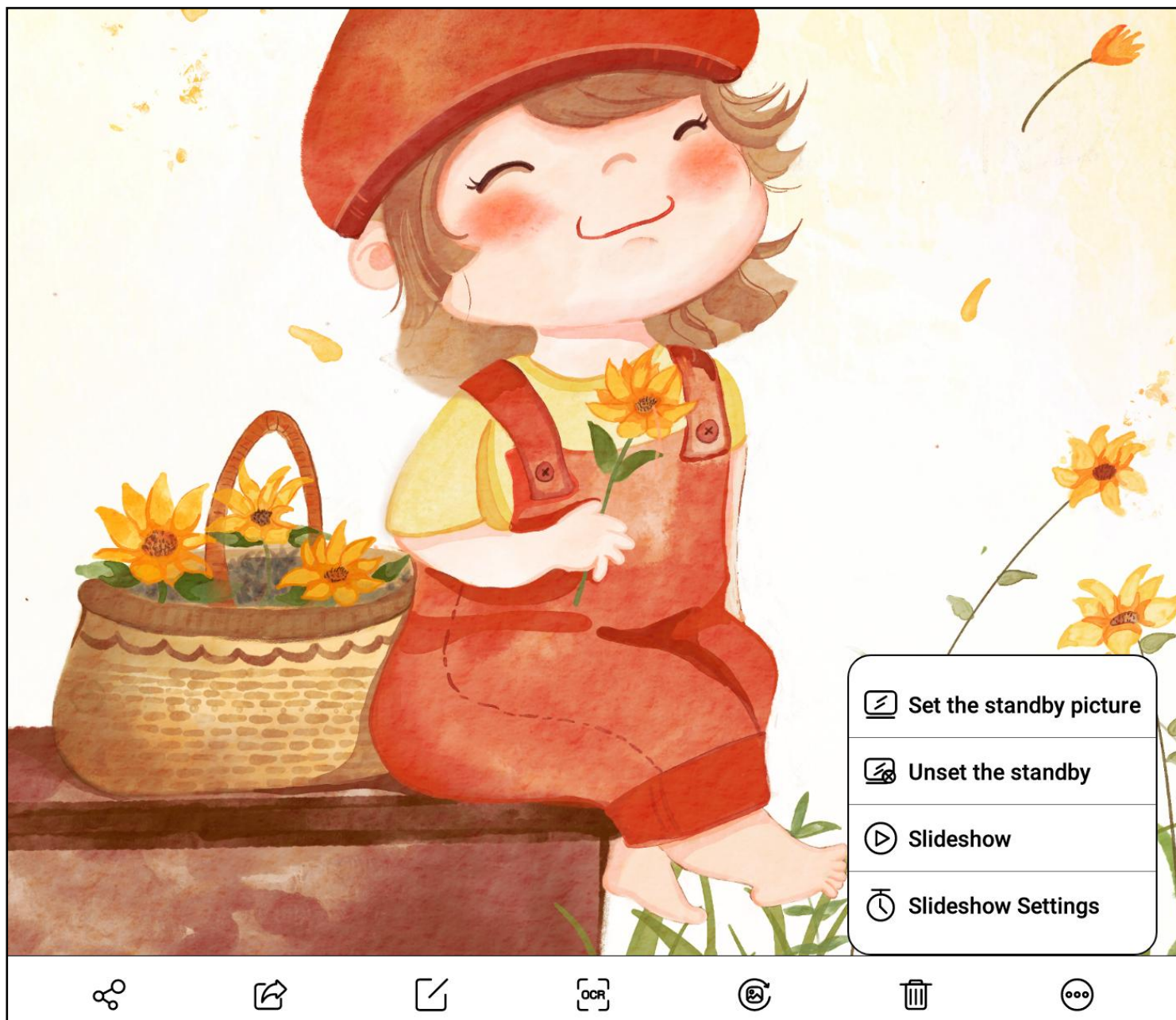

Click on “More” to set/cancel the screensaver for the current image.

Export as PDF

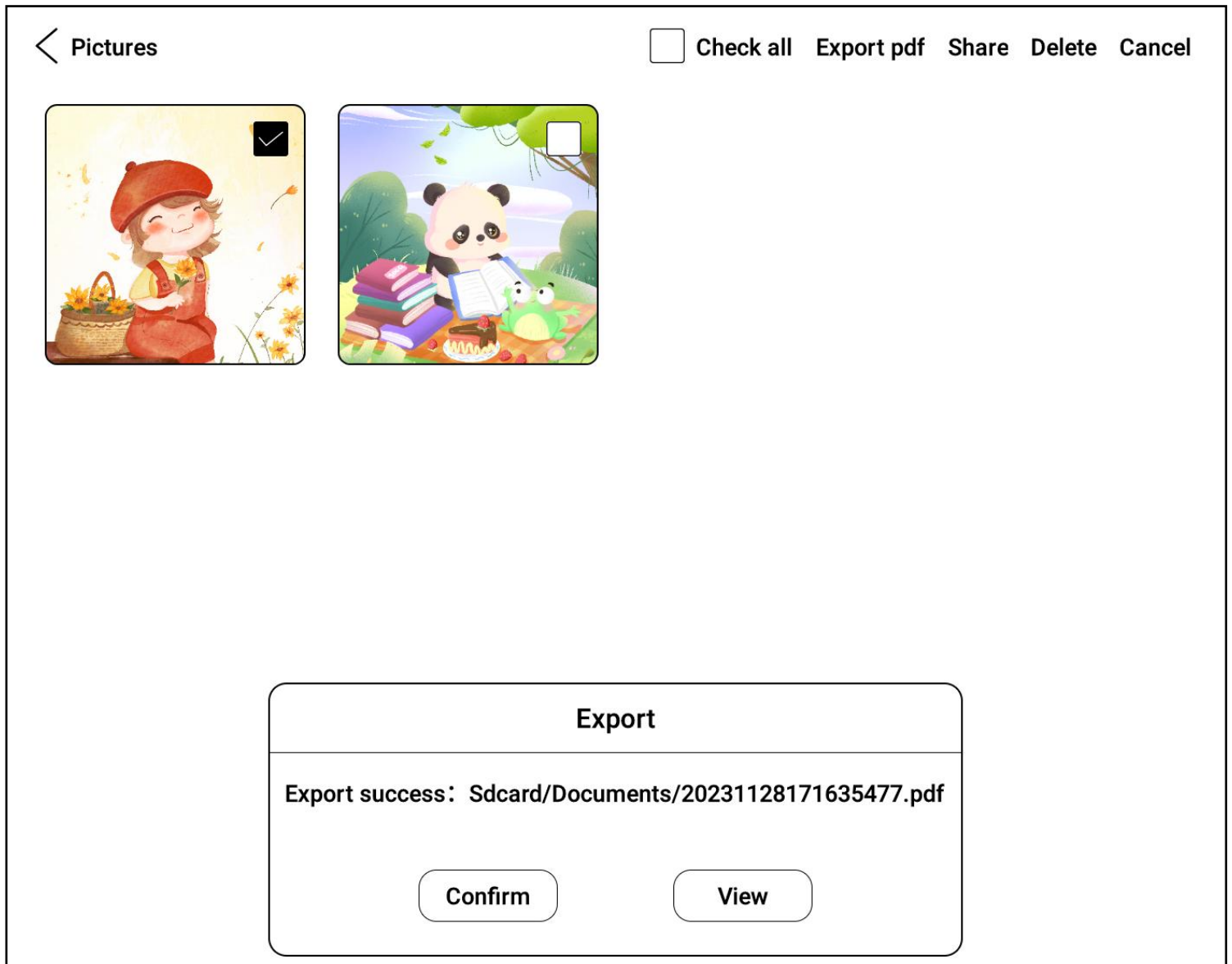

1. Click on "Select", choose multiple files.
2. Click on "Export" to PDF.
3. Export path is: Internal storage/Documents/.

Image Editing

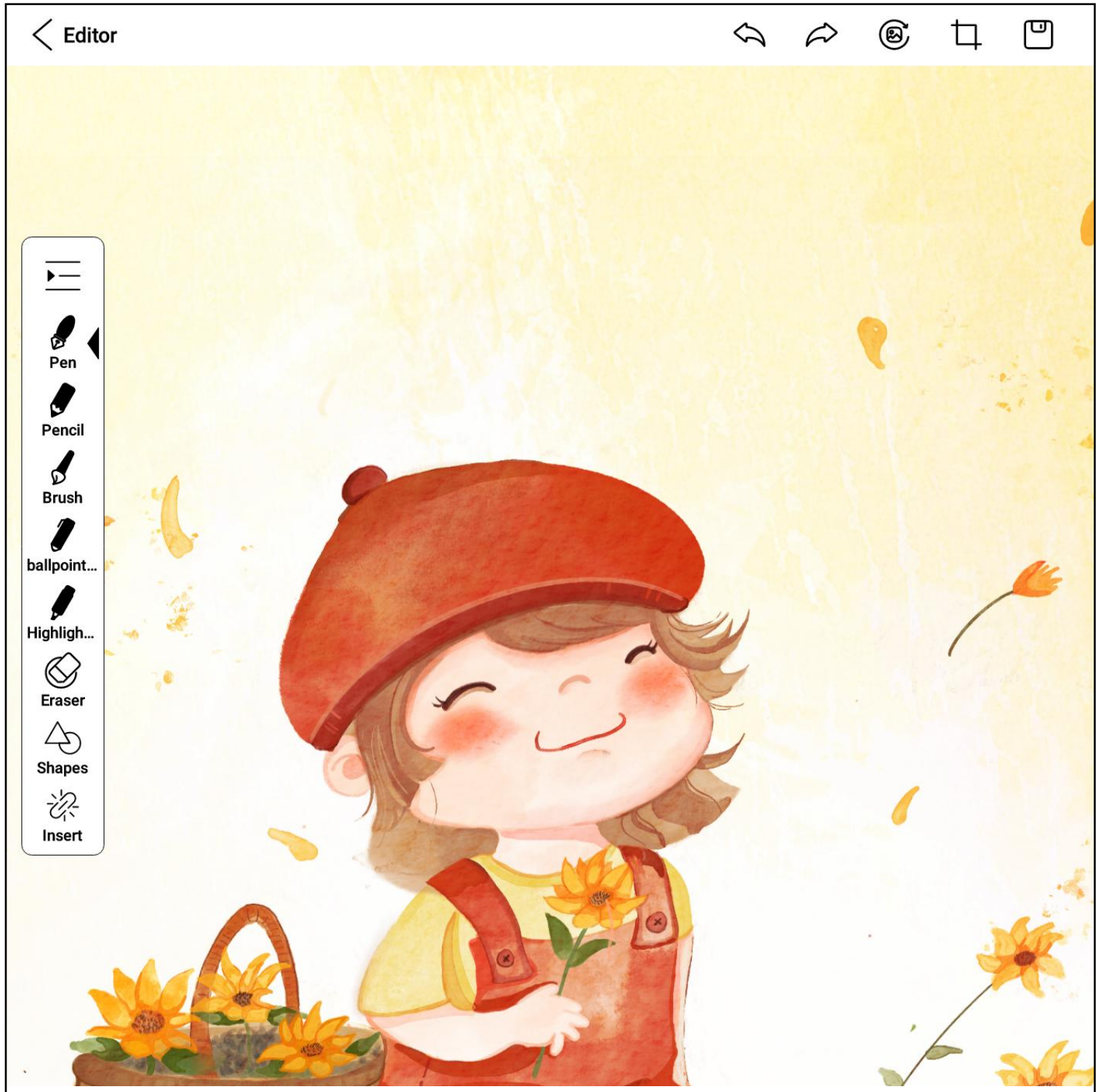

Click on "Edit" to make changes to the image, crop, insert text, etc.

OCR Recognition

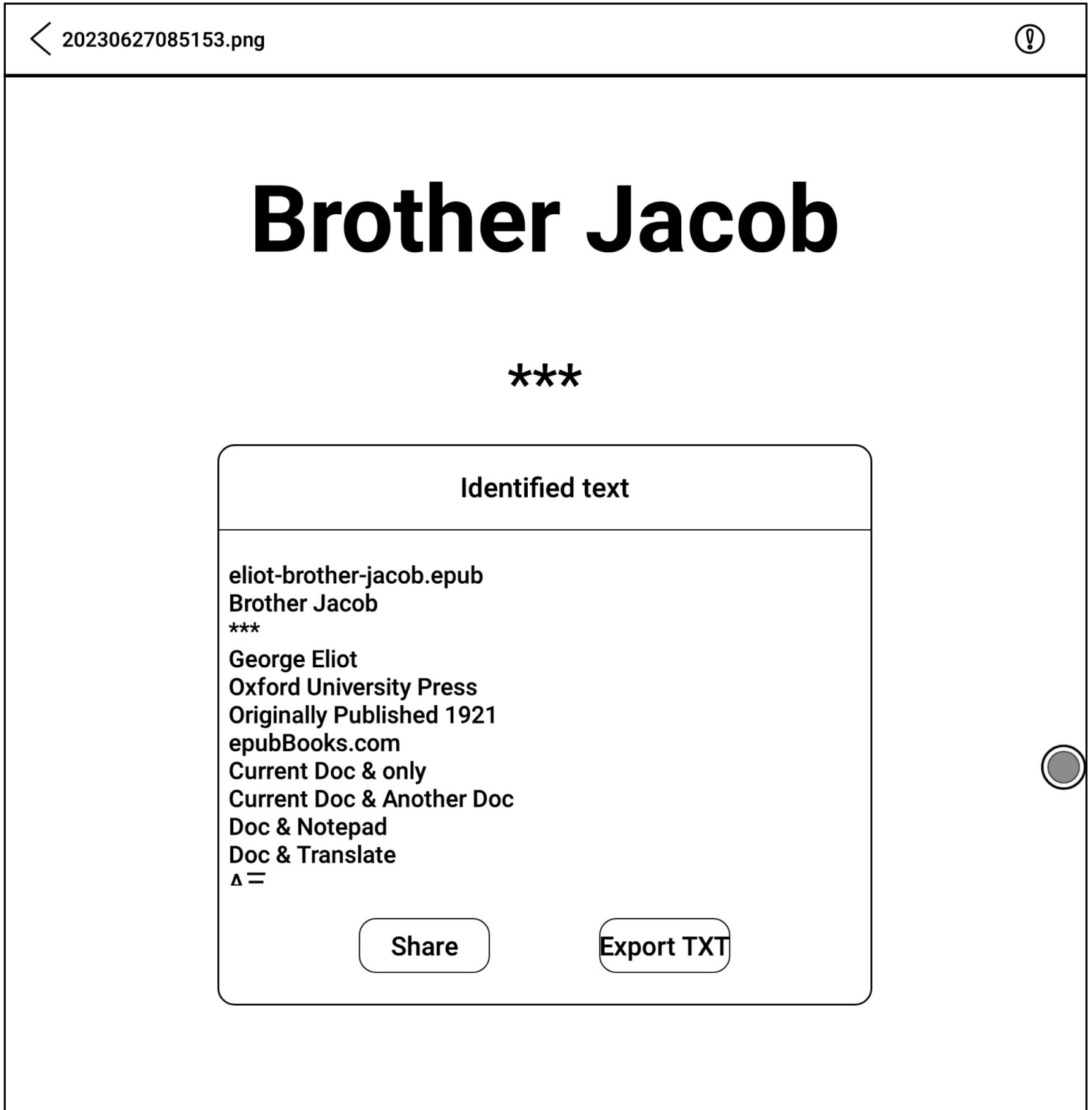

1. Click on "OCR" to recognize text in the image.
2. Share or export the recognized results as a TXT file.
3. Path is: Internal storage/Pictures/OCR/.

11. Document Scanning

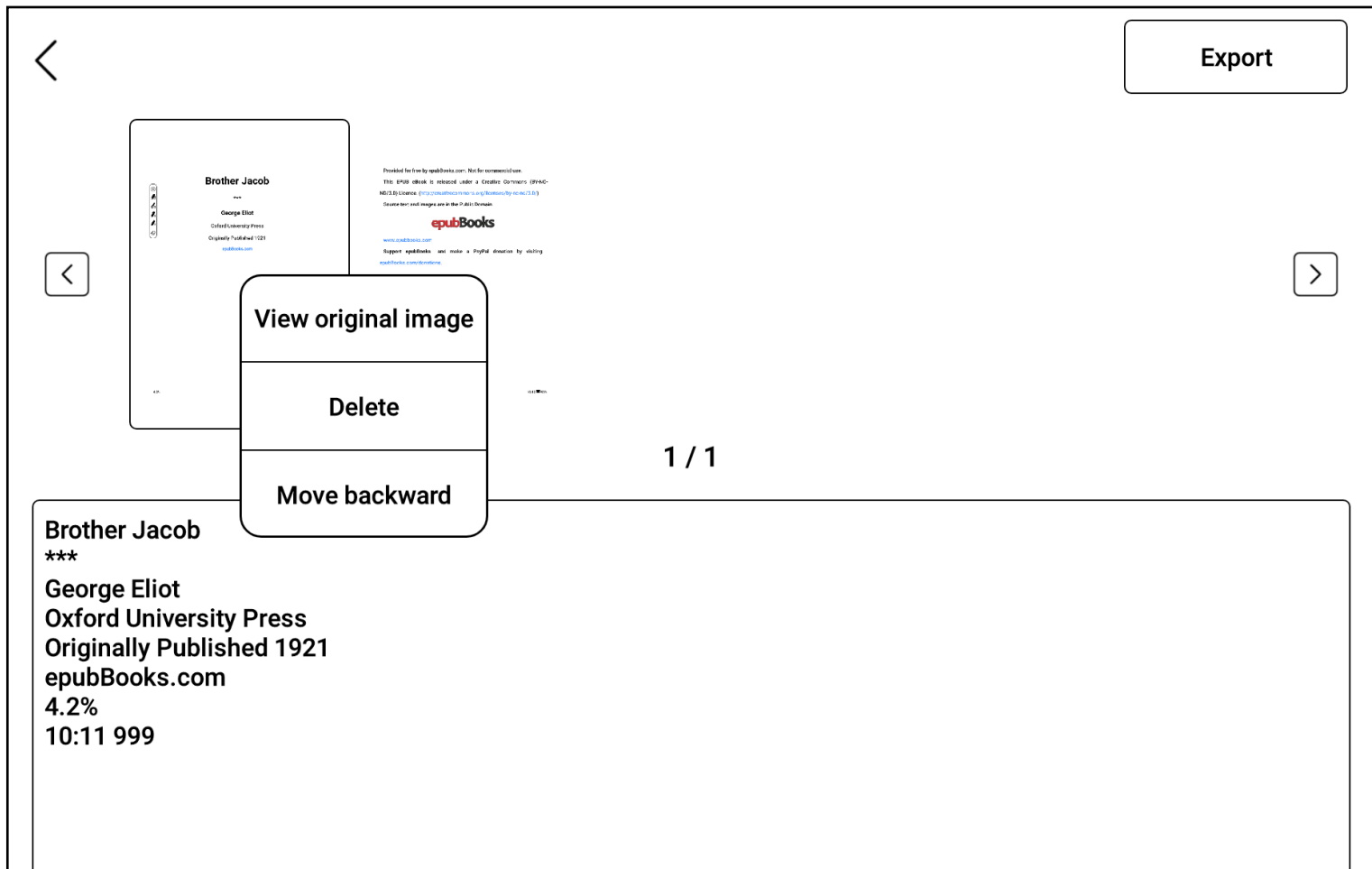

1. Scan documents by taking a photo with the camera.
2. Select files for recognition from "My Gallery".
3. Scan results can be exported as PDF or TXT files.
4. Export path is: Internal storage/OCR/.

12. App Center

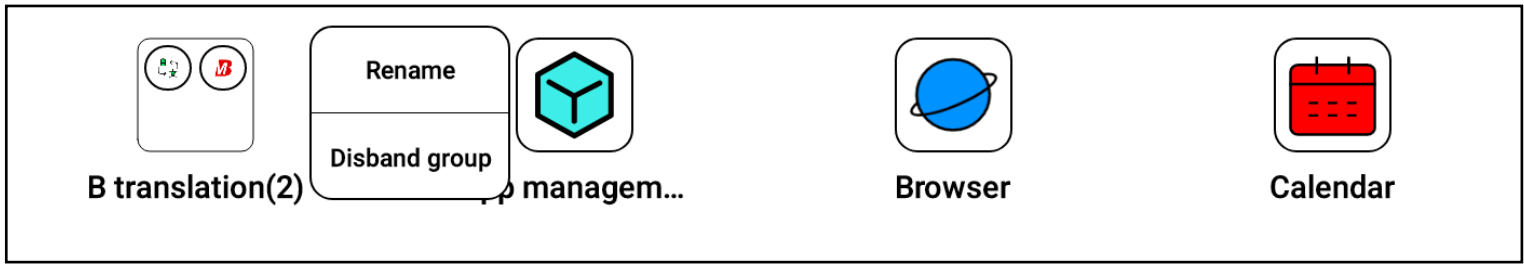

1. Long press app: Uninstall, manage (open, set app permissions, force stop, etc.), add to group.

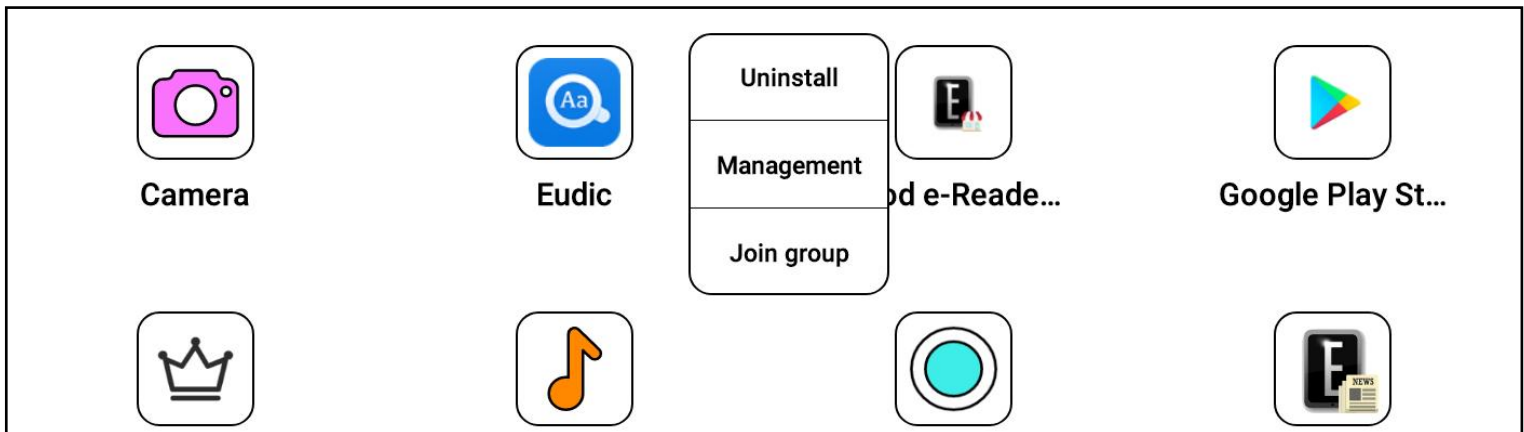

2. Long press app group: Rename, disband group.

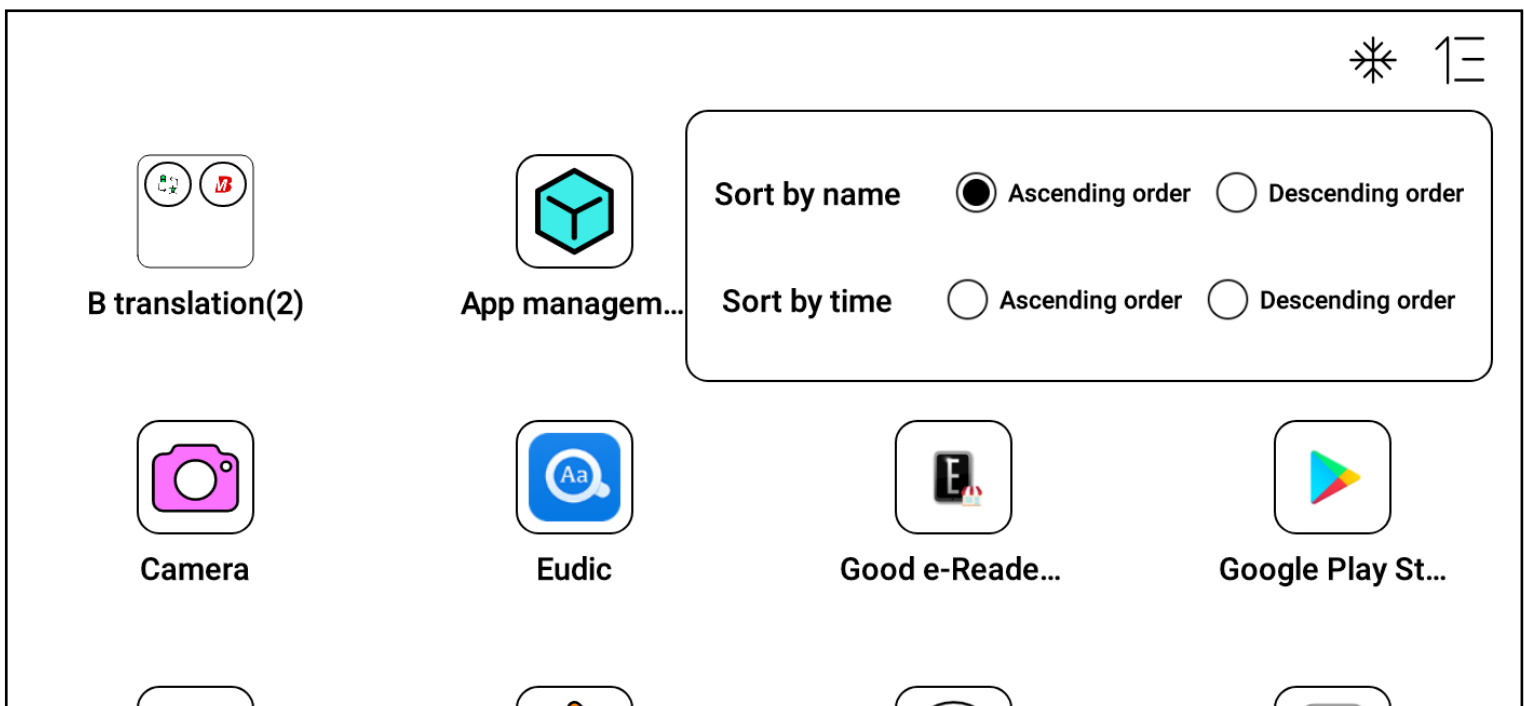

3. Sort: Sort apps by name or installation time in ascending or descending order.

13. E Ink Center

E Ink Center

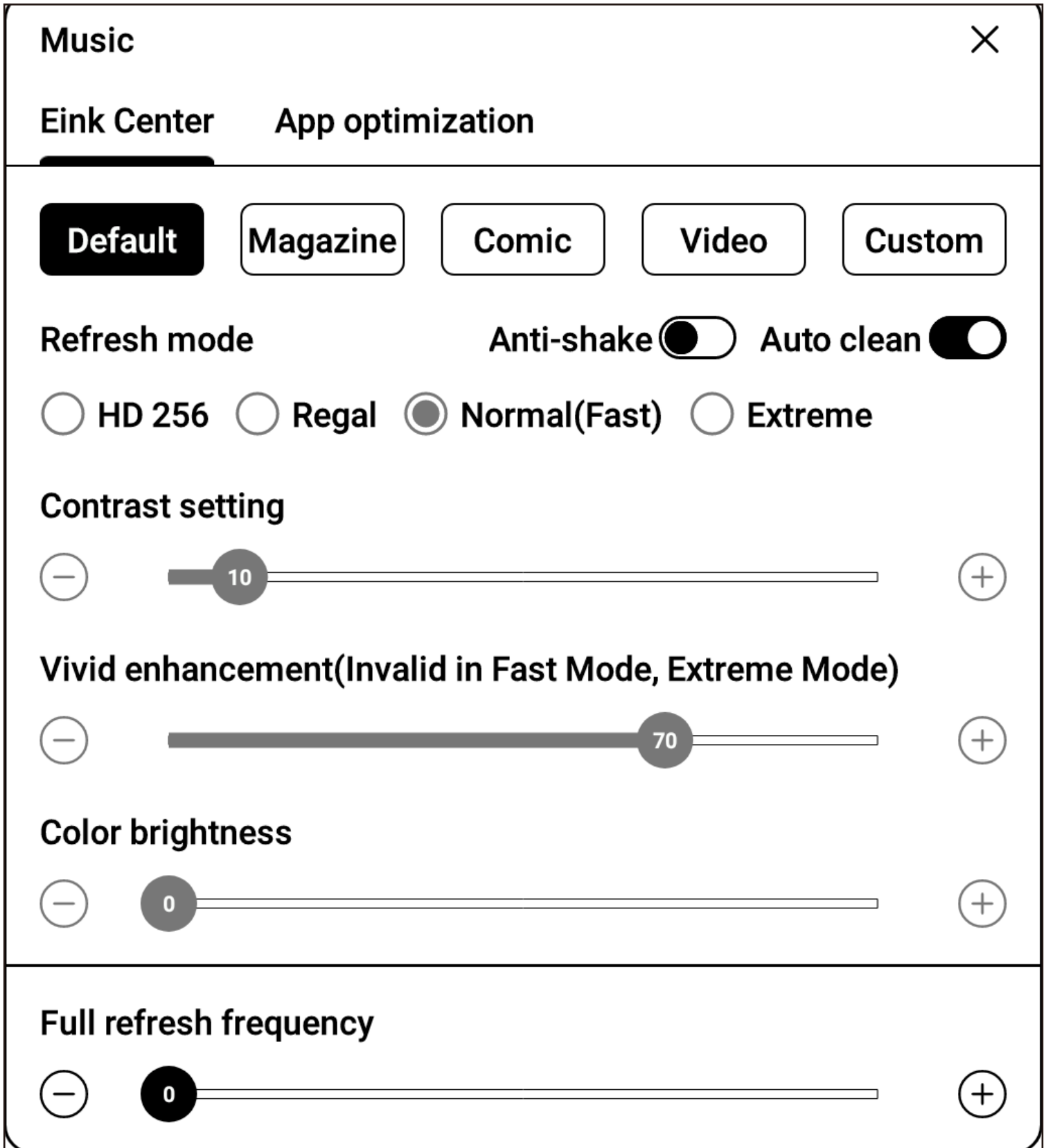

Operation: Pull down the status bar, select E Ink Center.

1. Refresh Mode: Set the refresh mode for the current app.

Default (normal / fast brush mode) – Suitable for most general scenarios, such as reading text.

Magazine (HD 256) – Ideal for high-definition images with multiple details, like magazines.

Comic (Regal mode) – Suited for scenarios that emphasize color over detail, like comics.

Video (speed mode) – Features fast refresh rates but with slightly more detail loss, suitable for browsing web pages and videos in ultra-fast mode.

Custom – Allows users to set their own parameters for "Dark Enhancement," "Vividness Enhancement," and "Brightness Enhancement" to meet different display requirements, ideal for advanced users.

2. Full brush frequency: brush the screen according to the set number of operations (if the value is 10, brush the screen once for 10 times).

App Optimization

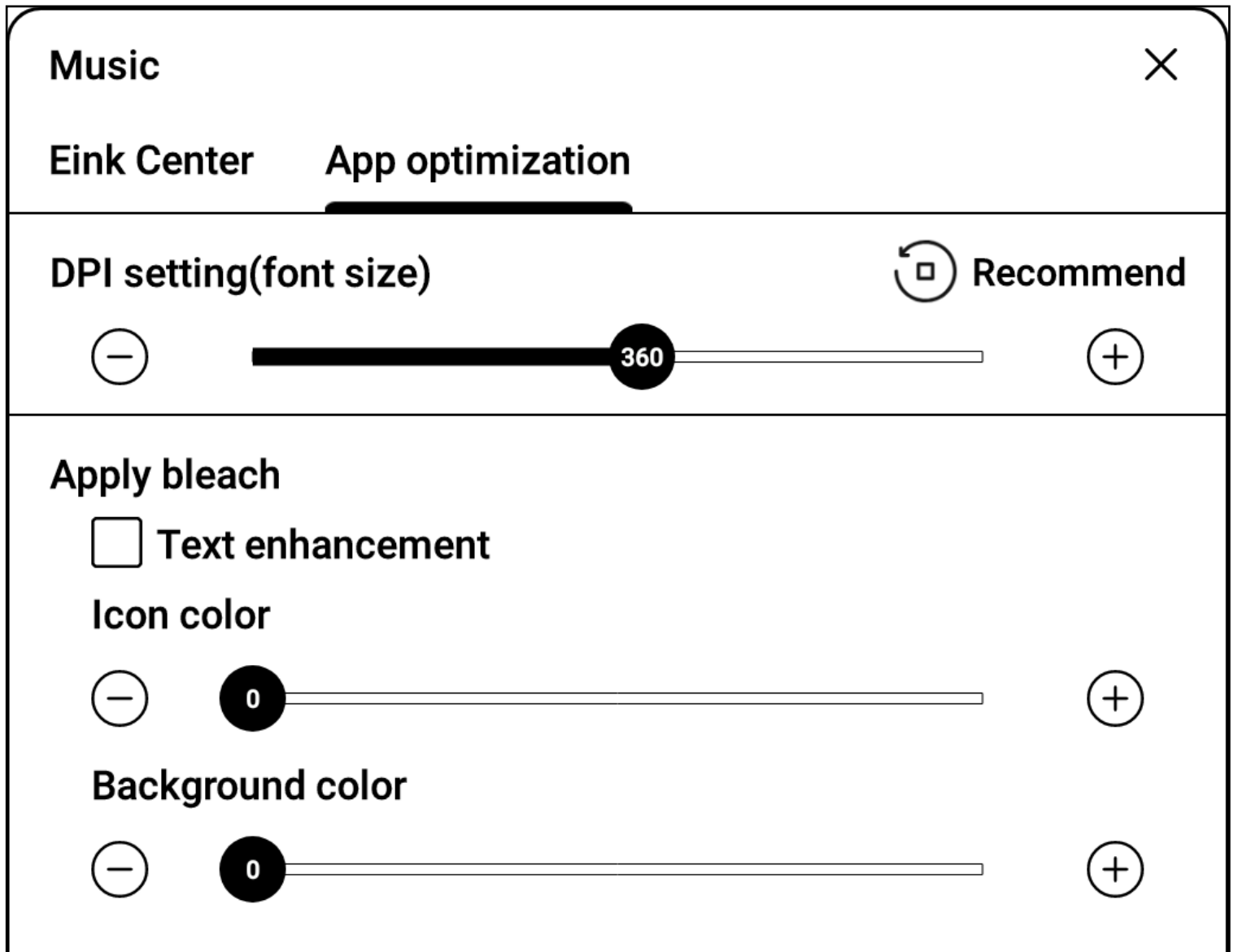

1. DPI setting: Adjust the overall page and font size of third-party apps;
2. Contrast Setting: Deepen the color of the third-party app fonts;
3. Text Enhancement: Bold the titles, menus, and text fonts of the third-party app.

14. Global Handwriting

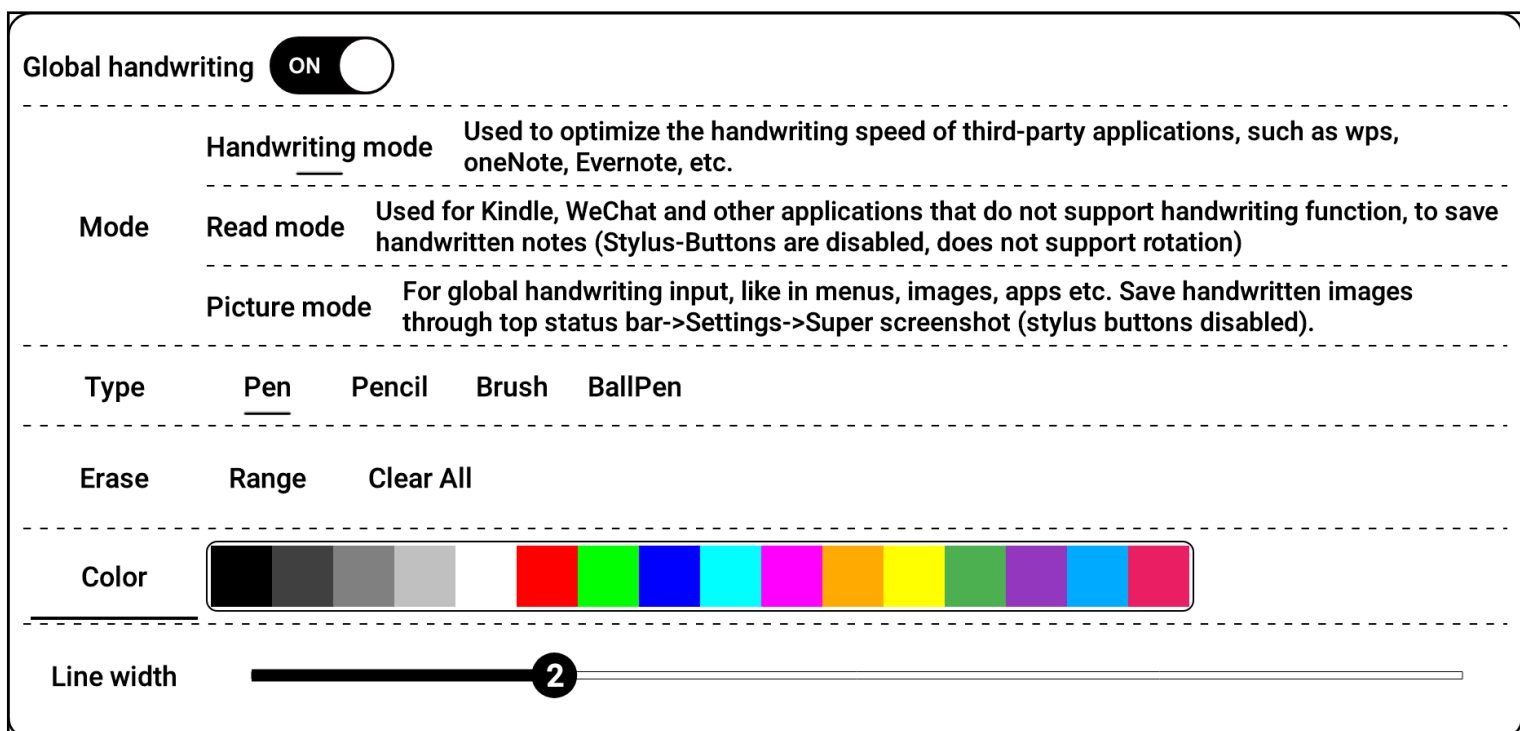



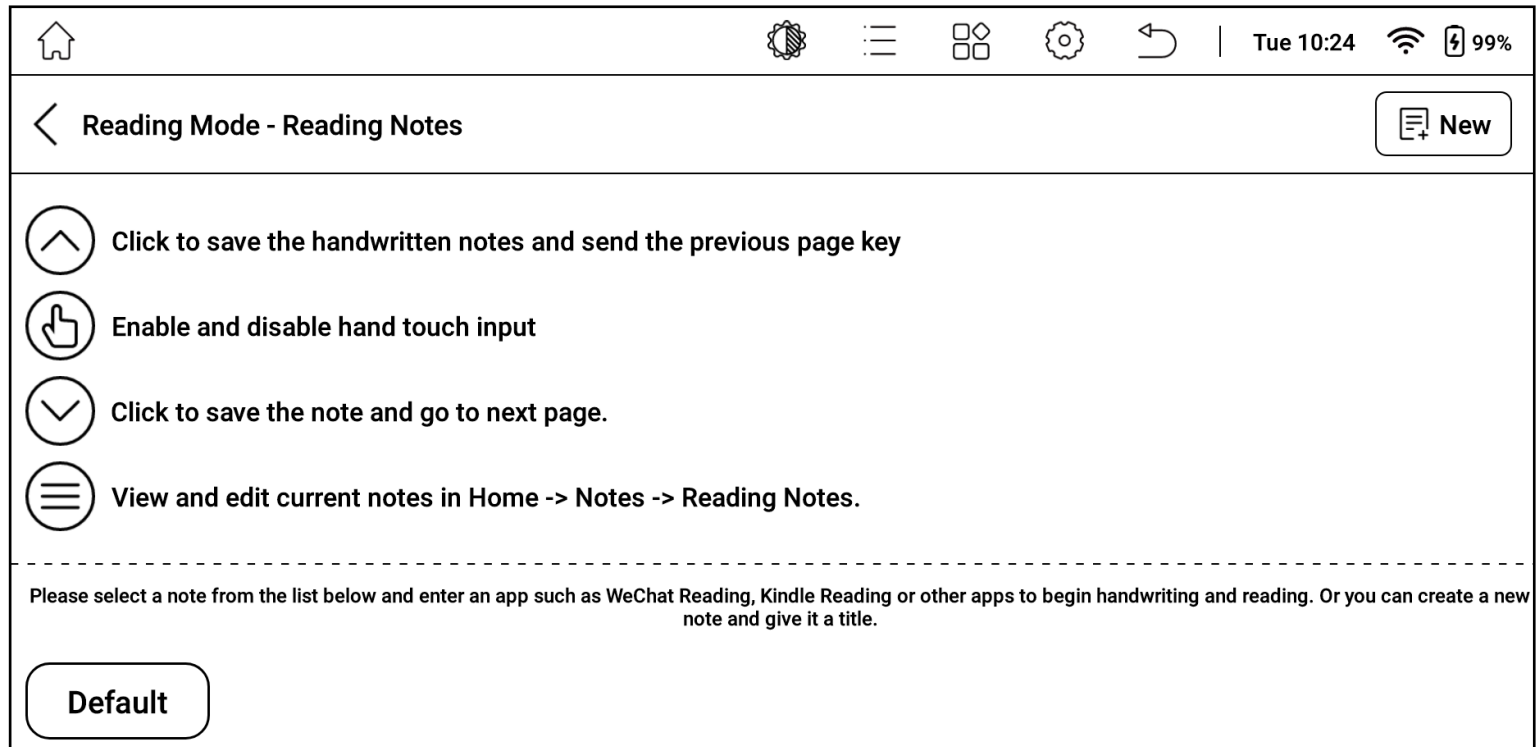

Operation: Pull down the status bar, select Global Handwriting.

1. **Handwriting Mode:** Effectively improves the handwriting speed of third-party handwriting apps, such as Youdao Cloud Notes, WPS, OneNote, etc. Features: Converts handwriting strokes into third-party app strokes, third-party notes disappear after being converted into global handwriting content.
2. **Reading Mode:** Supports handwriting annotations in thirdparty reading apps like WeChat Reading, Kindle Reading, etc., and can be saved as PDF format for cloud storage.
3. **Image Mode:** Allows handwriting on any app interface and saves and shares images. Features: Does not make apps that do not support handwriting support handwriting, allows you to handwrite on any interface, and handwriting can be saved through screenshots.

Reading Mode - Reading Notes



1. Click [] to turn the page up.
2. Click [] to turn the page down.
3. Click [] to disable touch.
4. Click [] to view the notes directory.

15. App Split Screen

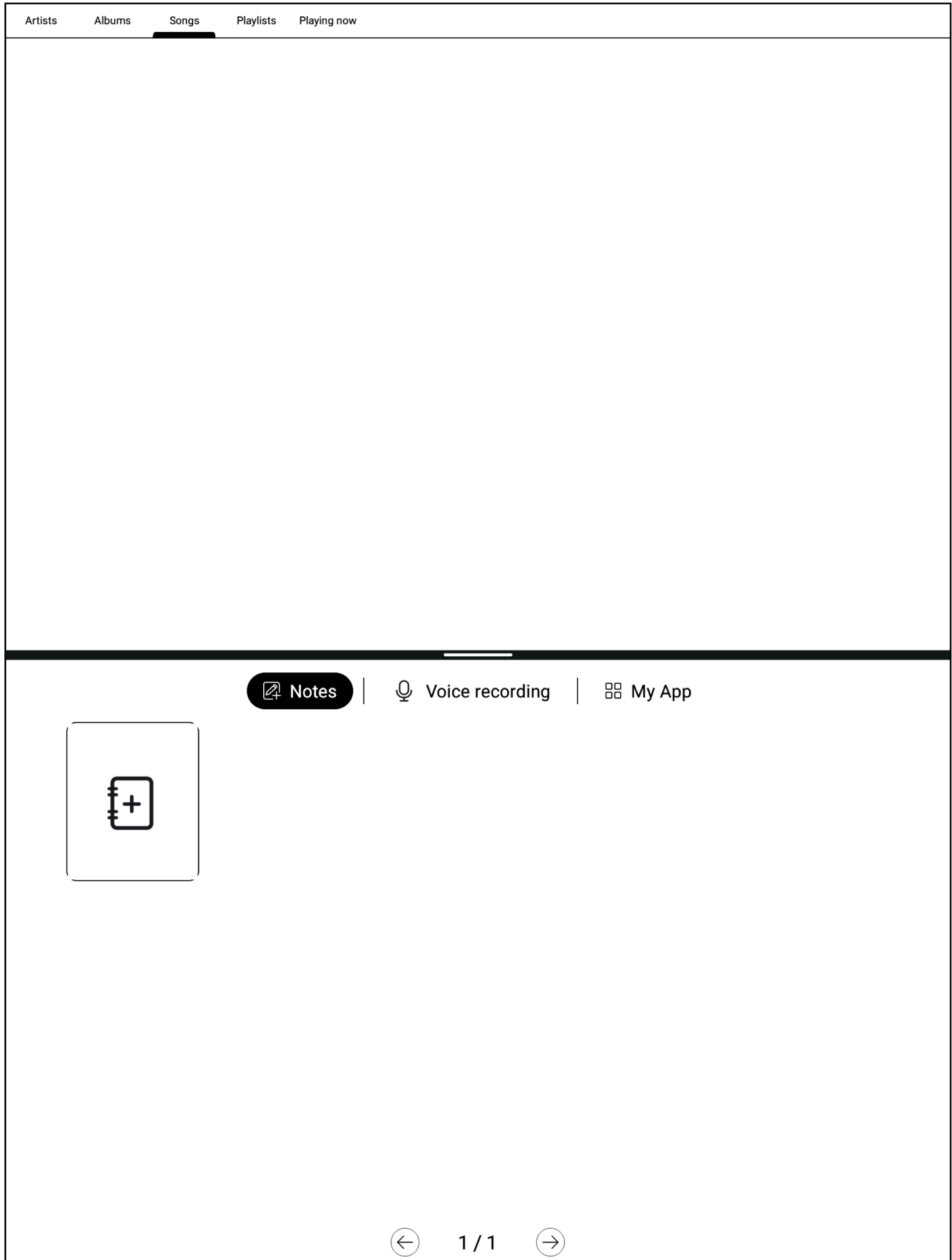

Operation

1. Pull down the status bar.
2. Select App Split Screen.

Dual Function

1. Notes: Read and take notes at the same time.
2. Voice recording: Video and voice transcription at the same time.
3. My App: Open two apps at the same time.

After Opening Dual Apps

1. Swap Positions: Pull down the menu, select App Split Screen, swap positions.
2. Exit Split Screen: Pull down the menu, select App Split Screen, exit split screen

16. Input Method Management

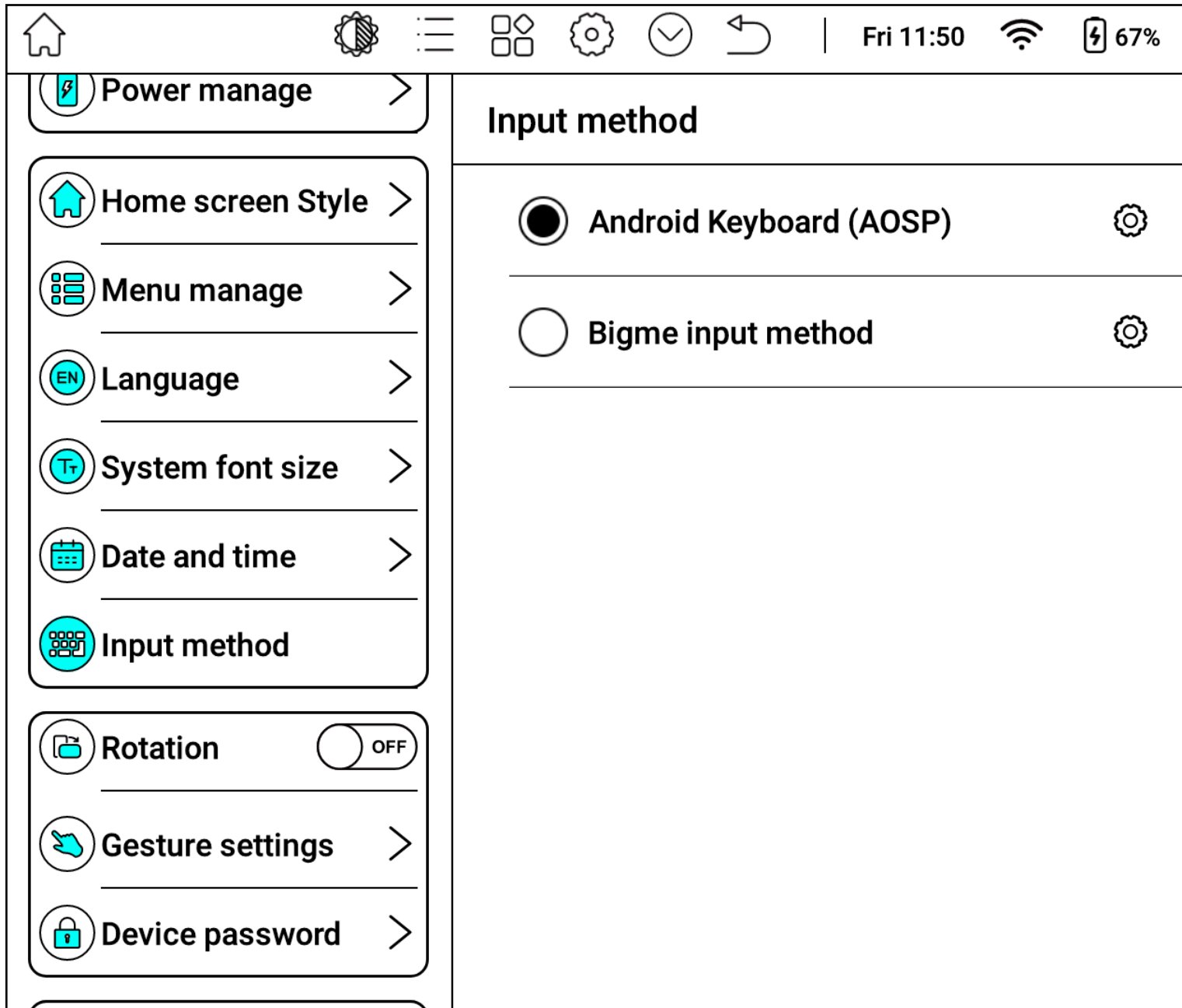

Changing the Input Method

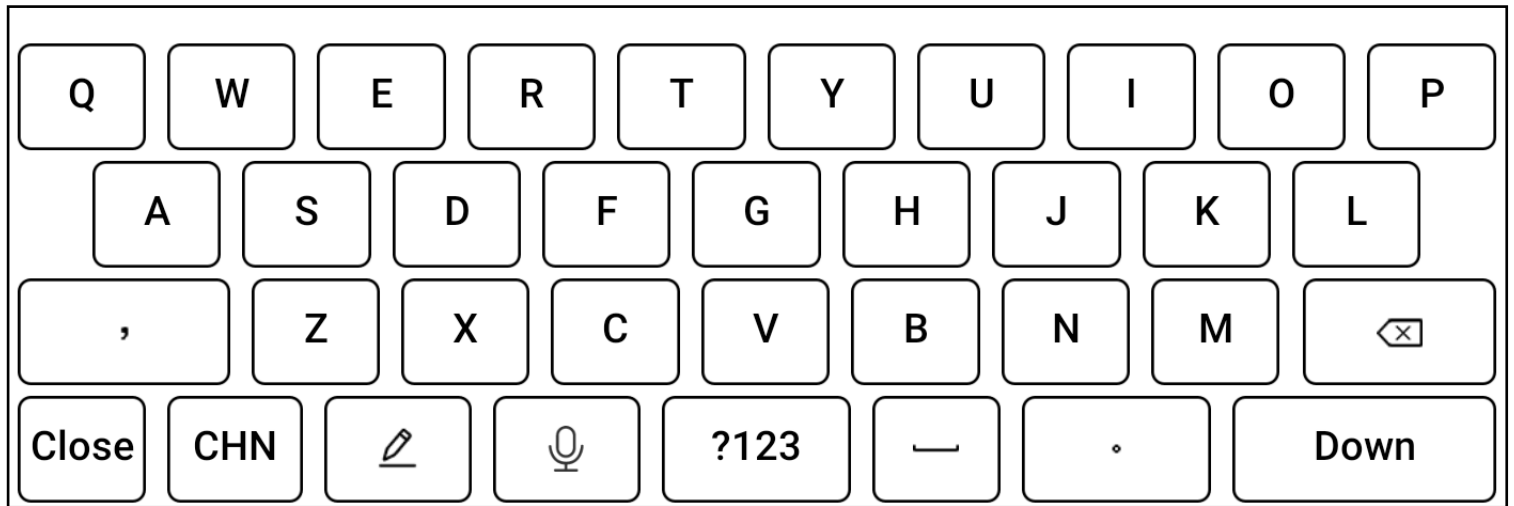

1. Click on [App Center] > [Settings] > [Input Method Management]
2. Select the input method you want to change

Bigme Input Method



1. Clicking on [Chinese/English] allows you to switch between Chinese and English input
2. Clicking on the [] icon allows you to use handwriting input, the content written by hand can be automatically recognized as standard characters, for example, if the system language default selection is "Simplified Chinese", handwriting input will be automatically recognized as "Simplified Chinese input", if the system language default selection is "English", handwriting input will be automatically recognized as "English input"
3. Clicking on [] allows you to enter voice input

Handwriting Input

Language Selection	
Simplified Chinese	<input checked="" type="radio"/>
English	<input type="radio"/>
Traditional Chinese	<input type="radio"/>
Deutsch	<input type="radio"/>
日本	<input type="radio"/>
한국인	<input type="radio"/>
Русский	<input type="radio"/>
Français	<input type="radio"/>
Total:41	1/6

0	1	2	3	4	5	6	7	8	9		关闭
,	°										
?	@										
—	↵										

In the handwriting interface, clicking on the [] icon - the language switch icon allows you to choose different languages, the content written by hand can be automatically recognized as the corresponding selected language text

17. File Download and Transfer

Cloud Reading and Writing - Download

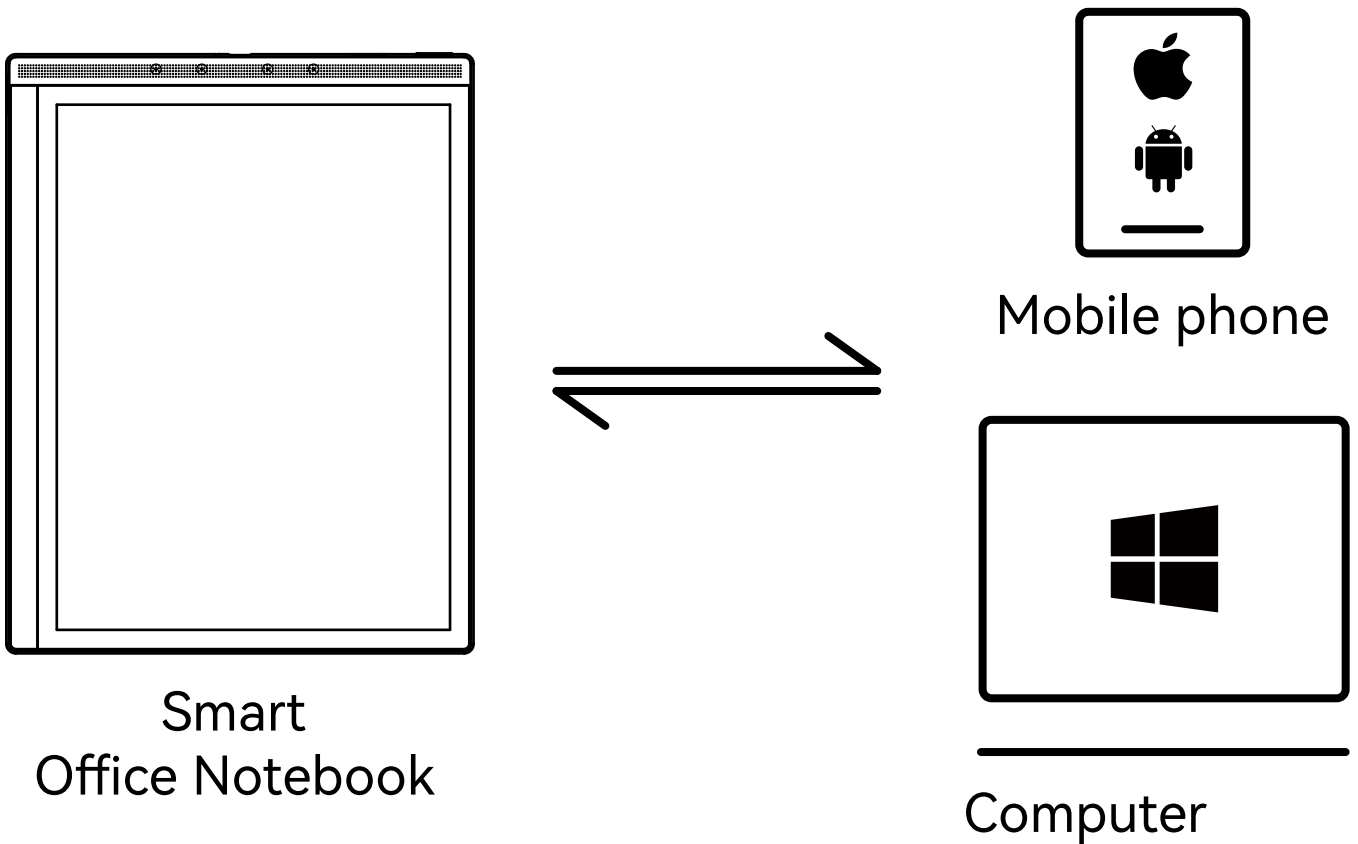

Through [Cloud Reading and Writing] can transfer files to each other



Scan the code to download or enter the address

<http://ereader.xrztech.com/BigmeCloud.html>

1. Smart office notebook and mobile phone or computer can transfer files, notes, and meeting records to each other
2. The login account for cloud reading and writing is the same as the registration login account for the Bigme smart notebook

Cloud Reading and Writing - Introduction

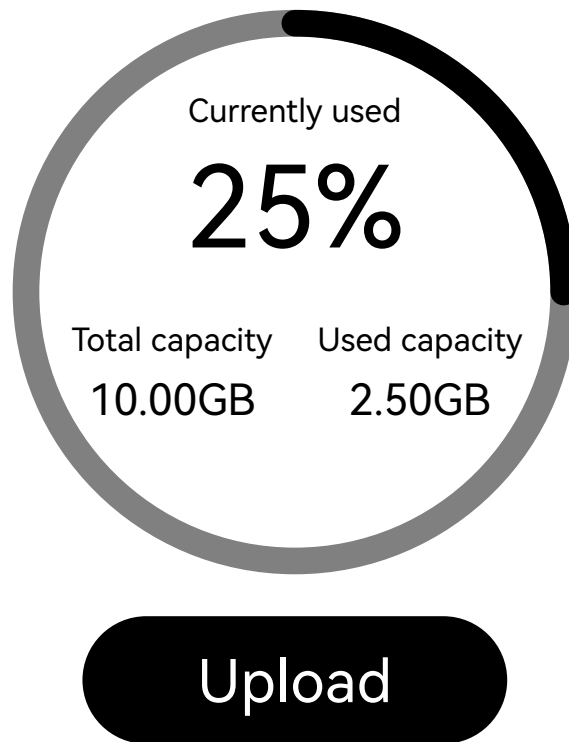

Upload:

1. Android/Harmony: Click on the upload icon, select the file to upload to Cloud Reading and Writing
2. iOS: Transfer the file to iCloud, then transfer it to Cloud Reading and Writing through iCloud



Meeting records



Random notes



Reading notes



Cloud synchronization

Others:

1. Meeting records: Meeting records uploaded to the cloud through the [Meeting Records] application on the office notebook

2. Random notes: Random notes uploaded to the cloud through the [Random Notes] application on the office notebook
3. Reading notes: Bookmarks, annotations, handwritten notes, etc., added when opening books in the bookshelf or bookstore, uploaded to the cloud as reading notes
4. Document synchronization:
 - a. Files transferred to Cloud Reading and Writing from the mobile phone
 - b. Files uploaded to the cloud from the office notebook can all be viewed in the document view

Cloud Files

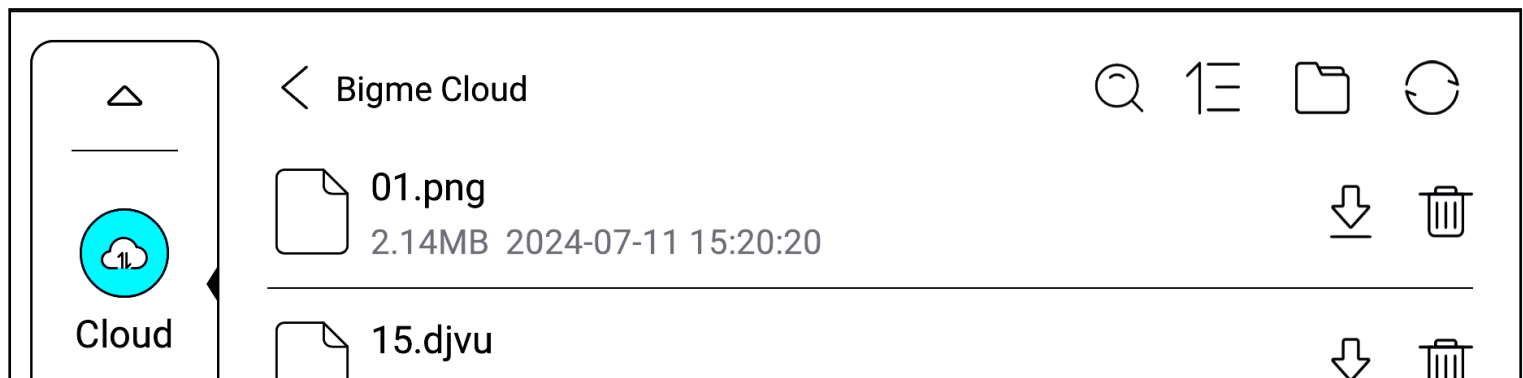

- 1 [Refresh] will synchronize the files uploaded to the cloud in the cloud file view
- 2 [Download] will download the files uploaded to the cloud to the local storage, the files will be saved in the local storage Download directory
- 3 [Delete] will delete the files uploaded to the cloud, once the files are deleted, they cannot be recovered, please operate with caution

Transfer books over WiFi

1. Enter the application "Bookshelf" – click on "Import" in the upper right corner of the page – select WiFi Import
2. Connect the smart office book and the computer to the same WiFi hotspot, enter the pop-up website address of the first step smart office book in the computer browser
3. Select a local file to import and upload the file

USB Transfer – Windows

Connect the device to the computer using a USB data cable, after the computer recognizes it, you can transfer files.

If the computer fails to recognize it, please perform the following operations:

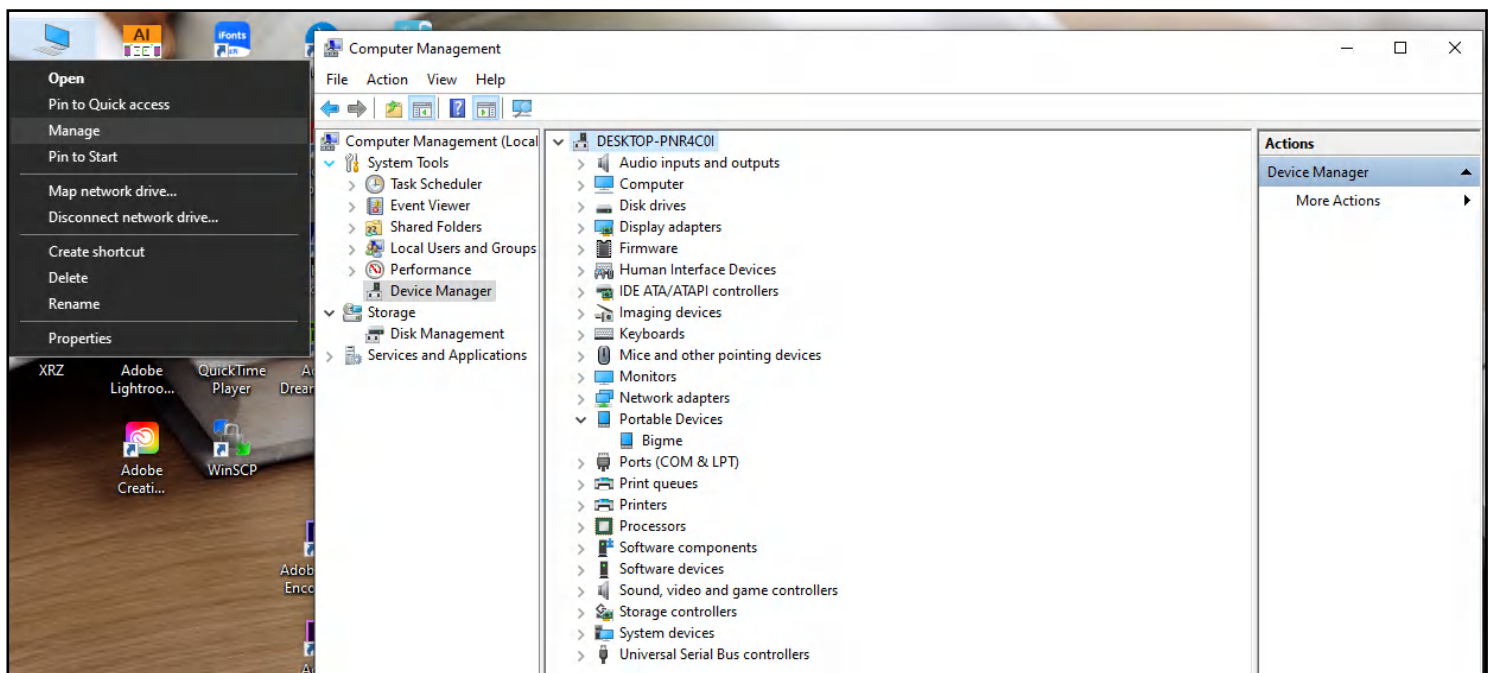

1. After the device is connected to the computer, right-click on the computer desktop [This PC], select [Manage] > [Device Manager] > [Portable Device-Bigme]



2. Right-click on [Bigme], select [Update Driver Software] > [Manual Search]

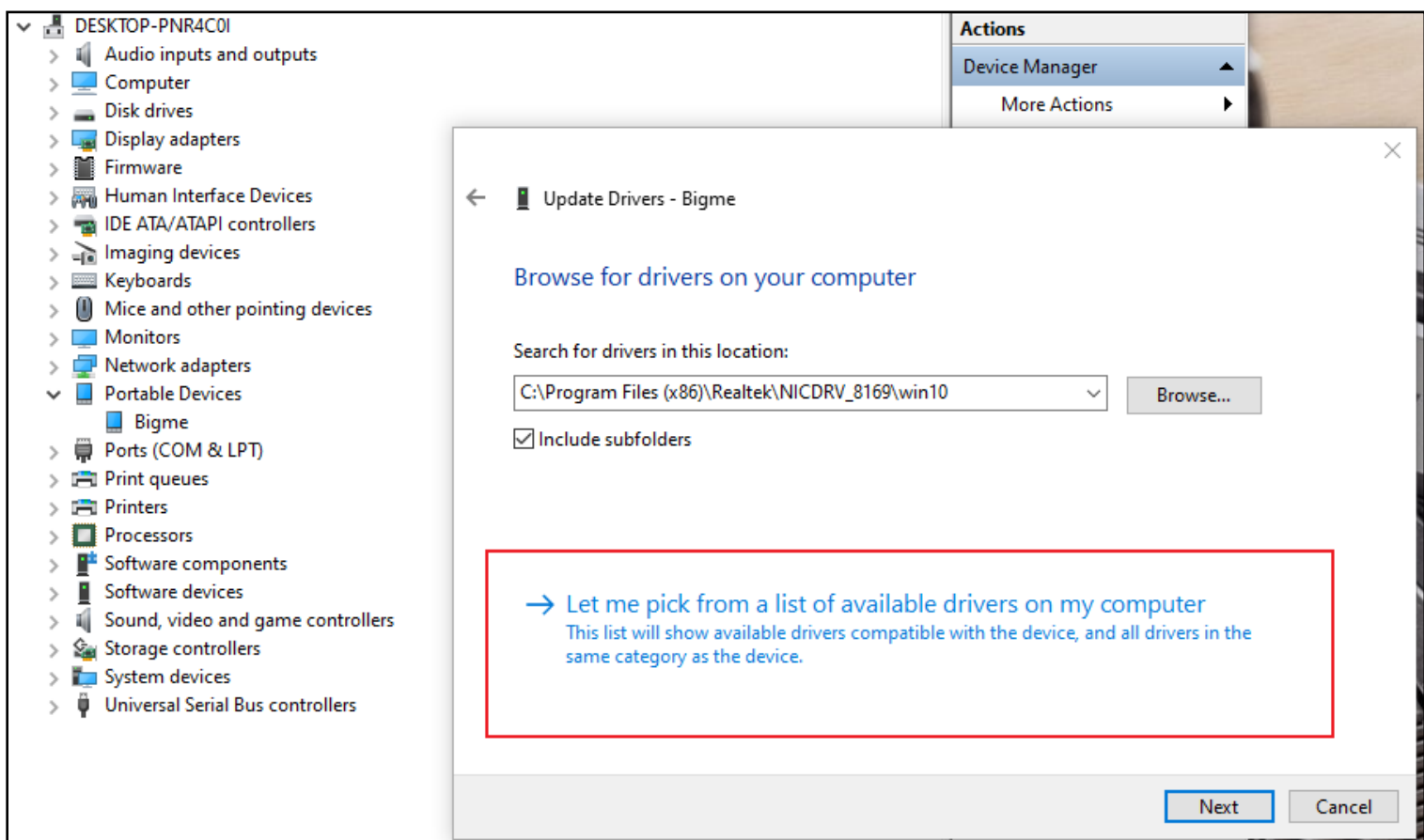

3. Select [Let me pick from a list of device drivers on my computer]

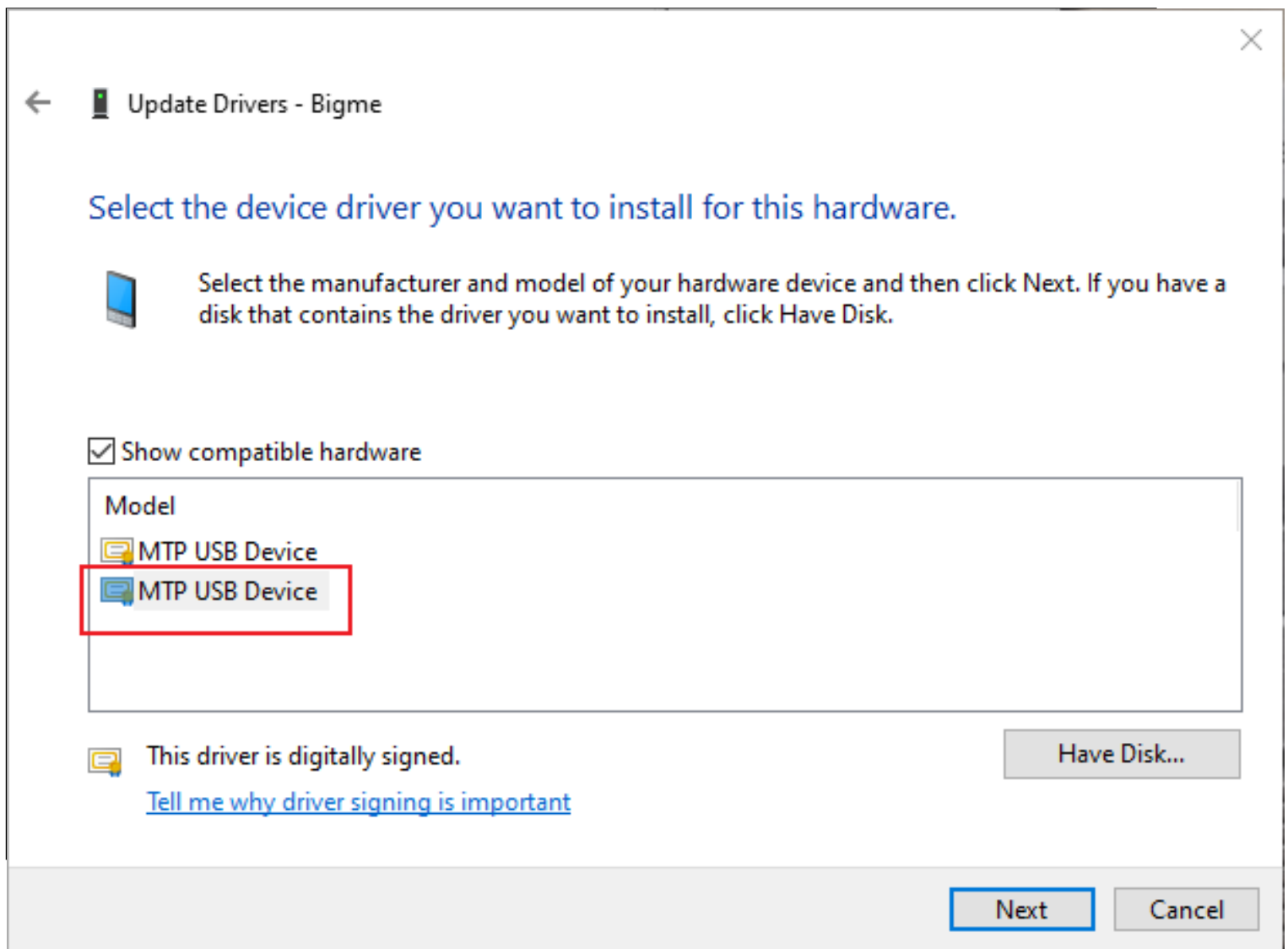

4. As shown in the figure, select [MTP USB Device], click [Next], wait for the update to complete, click [Close] to finish.

USB Transfer - Mac

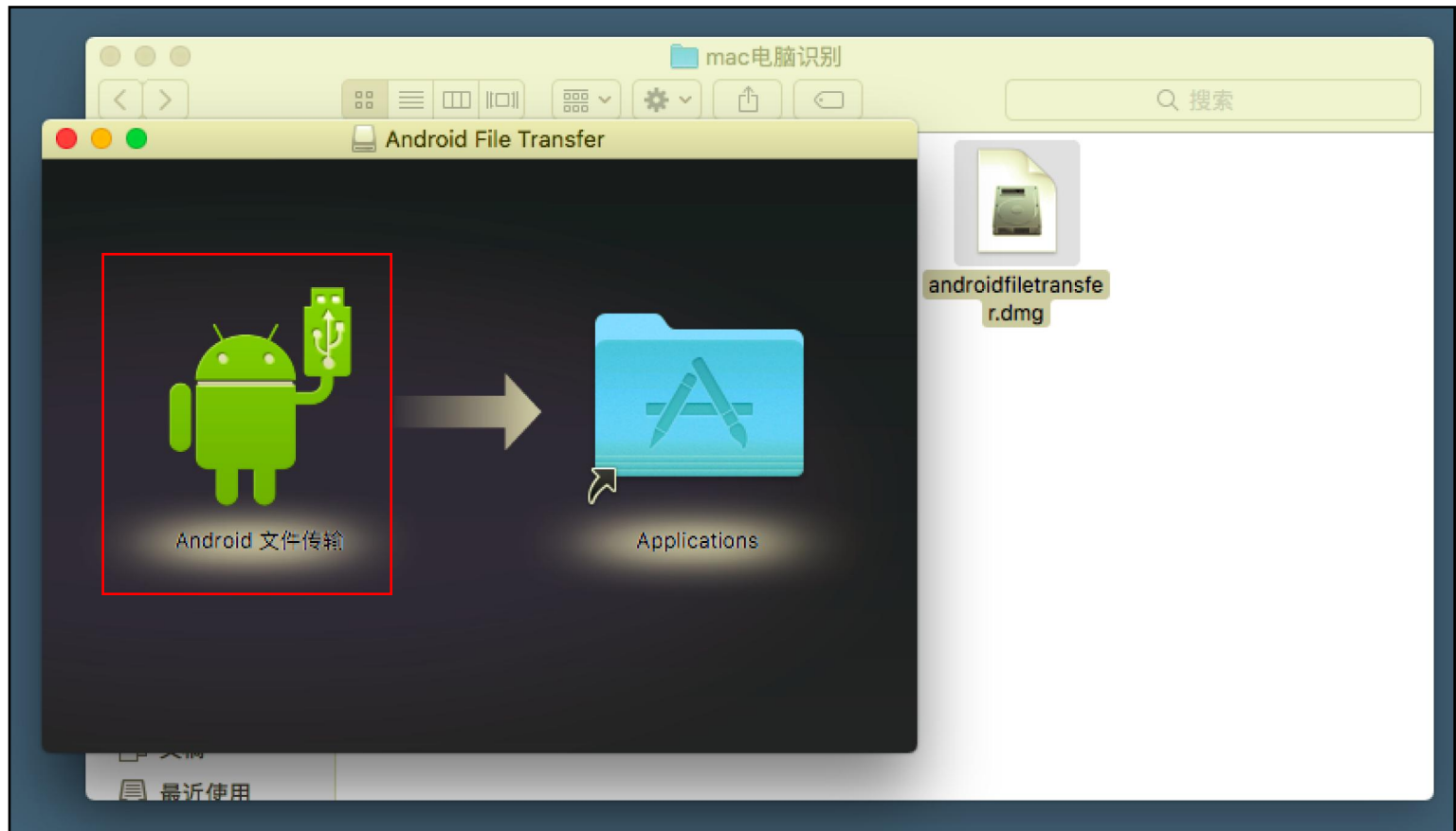

1. Install the [androidfiletransfer.dmg] file
2. Double-click on [Android File Transfer], you can transfer files after the folder window pops up

18. Floating Ball

Home icon | Settings icon | Menu icon | App icon | Gear icon | Refresh icon | Tue 10:31 | Wi-Fi icon | 99% battery icon









< Navigation Ball Set

Open the floating ball

Volume key to turn page

The size of the floating ball >

Button customization Reset

<p>Key 1</p>  <p>Homepage</p>	<p>Key 2</p>  <p>Back</p>	<p>Key 3</p>  <p>Multi-task switching</p>
<p>Key 4</p>  <p>Full refresh</p>	<p>Key 5</p>  <p>Screenshot</p>	<p>Key 6</p>  <p>Page key</p>
<p>Key 7</p>  <p>Navigation Ball Set</p>	<p>Key 8</p>  <p>Rotation</p>	<p>Key 9</p>  <p>Shut down and restart</p>

1. A control menu that floats on the top layer of the interface, you can customize the settings for 9 button functions
2. Clicking the center button can expand or collapse the floating menu
3. After modifying the options in the floating ball, you need to reopen the enable switch;

Button Settings

The 9 expanded buttons support customizing various common functions, including some of the system's own operations, application switching, etc.

19. Settings

About This Machine

Shutdown Never >

Power manage >

Home screen Style >

Menu manage >

Language >

System font size >

Date and time >

Input method >

Rotation OFF

Gesture settings >

Device password >

Google service >

Account Manage >

System update >

Log report >

After-sales service >

About the device

About the device

Device name	AI>Note
Product model	B1051C
System version:	B1051C_R_2.7.0_20240902_Beta
Serial number	0123456789ABCDEF
WLAN MAC address	00:08:22:A4:5E:A7
Bluetooth address	7E:5F:46:E3:4C:4C
Android version	14
Processor	Octa-core 2.4GHz
RAM	6GB
Storage capacity	Available97.06GB/Total128GB
Screen resolution	1860x2480

User manual >

User guide >

FAQs >

Factory reset

1. You can query device model, version number and other device information, and make global settings for the system in the settings interface;
2. You can download the user manual for the corresponding model
3. You can view the user guide
4. You can view common problems
5. You can restore factory settings

Note: Restoring factory settings will clear all user data, please back up your data in advance, operate with caution

WIFI Settings

1. Select "Turn on WIFI", the device will automatically search for available WIFI hotspots, select the corresponding hotspot from the displayed WLAN network list, enter the password and other required information, connect to the WIFI hotspot. After successful connection, the system bar will show WIFI connection successful and the WIFI signal icon will appear.
2. After the WLAN hotspot is successfully set up for the first time, it will automatically record the information of the hotspot, and the next time you connect, you only need to select the WLAN switch in the drop-down status bar to automatically connect to the valid WIFI hotspot.

Bluetooth Settings

1. Turn on the Bluetooth switch, you can search for available Bluetooth devices nearby, send connection requests
2. Bluetooth needs to be paired on both ends of the device before it can be used

Language

The language settings interface allows for the configuration of the system's language.

Date and Time

1. You can choose to set the time automatically or manually. When connected to the internet, the automatic setting will match the device time according to the network time.
2. For manual setting, you need to set the date, time zone, and time yourself.
3. You can set the time to be displayed in 12-hour or 24-hour format, as well as the date display method, according to your usage habits.

Device Password

You can set a numerical password for the device.

Account Management

The accounts needed for data synchronization during device usage are managed uniformly.

Gesture Settings

1. By default, upward swipes from the bottom and left-right swipes from the sides are enabled, while up-down swipes from the sides are disabled.
2. Upward swipes from the bottom can be customized for various functions such as returning to the home page, going back, taking screenshots, switching tasks, clearing cache, full refresh, E ink center, etc.
3. Up-down swipes from the sides need to be enabled for custom functions, which can be set for volume, warm light, and cold light.

20. Disclaimer

Bigme Cloud Literacy Technology Co., Ltd. reserves the right to make changes to the product specifications and content in the "User Manual" without further notice.

1. All book interfaces in this manual are for display purposes only and are not pre-installed books.
2. Due to different software versions, some functions or interfaces may not be consistent with the manual, and the actual product shall prevail.

21. FCC Statement

This equipment has been tested and found to comply with the limits for a Class B digital device, pursuant to part 15 of the FCC rules.

These limits are designed to provide reasonable protection against harmful interference in a residential installation. This equipment generates, uses and can radiate radio frequency energy and, if not installed and used in accordance with the instructions, may cause harmful interference to radio communications. However, there is no guarantee that interference will not occur in a particular installation.

If this equipment does cause harmful interference to radio or television reception, which can be determined by turning the equipment off and on, the user is encouraged to try to correct the interference by one or more of the following measures:

- Reorient or relocate the receiving antenna.
- Increase the separation between the equipment and receiver.
 - Connect the equipment into an outlet on a circuit different from that to which the receiver is connected.
- Consult the dealer or an experienced radio/TV technician for help.

To assure continued compliance, any changes or modifications not expressly approved by the party.

Responsible for compliance could void the user's authority to operate this equipment. (Example- use only shielded interface cables when connecting to computer or peripheral devices).

This equipment complies with Part 15 of the FCC Rules. Operation is subject to the following two conditions:

- (1) This device may not cause harmful interference, and

(2) This device must accept any interference received, including interference that may cause undesired operation.

Specific Absorption Rate (SAR) information: This device meets the government's requirements for exposure to radio waves. The guidelines are based on standards that were developed by independent scientific organizations through periodic and thorough evaluation of scientific studies. The standards include a substantial safety margin designed to assure the safety of all persons regardless of age or health.

FCC RF Exposure Information and Statement the SAR limit of USA (FCC) is 1.6 W/kg averaged over one gram of tissue. Device types: device has also been tested against this SAR limit. This device was tested for typical body-worn operations with the back of the Tablet kept 0mm from the body. To maintain compliance with FCC RF exposure requirements, use accessories that maintain an 0 mm separation distance between the user's body and the back of the Tablet.

The use of belt clips, holsters and similar accessories should not contain metallic components in its assembly. The use of accessories that do not satisfy these requirements may not comply with FCC RF Exposure requirements, and should be avoided.