



E52-900NW22S User Manual

Wireless Networking Module



LIST

E52-900NW22S USER MANUAL	0
DISCLAIMER AND COPYRIGHT NOTICE.....	0
I.PRODUCT DESCRIPTION	1
1.1 PRODUCT INTRODUCTION	1
1.2 FUNCTION DESCRIPTION	1
1.3 FUNCTION DESCRIPTION	2
1.4 NETWORK TOPOLOGY	3
1.5 APPLICATION SCENARIO	3
II.SPECIFICATIONS	4
2.1 LIMIT PARAMETERS	4
2.2 WORKING PARAMETERS	4
III. MECHANICAL DIMENSIONS AND PIN DEFINITION	5
IV. RECOMMENDED CONNECTION DIAGRAM	7
V. TEST SUITE	8
5.1 TEST SUITE INTRODUCTION.....	8
VI. COMMAND INTRODUCTION	9
6.1 INTRODUCTION TO AT COMMANDS	9
6.2 COMMAND INSTRUCTION SET.....	9
6.3 QUERY INSTRUCTION SET.....	10
6.4 SETTING UP THE INSTRUCTION SET.....	12
6.5 PARAMETER VALUE TABLE	14
6.6 PARAMETER NOTES	16
VII. BASIC FUNCTION INTRODUCTION	18
7.1 GET THE MAIN PARAMETERS OF THE MODULE	18
7.2 UNICAST COMMUNICATION (UNICAST)	19
7.3 MULTICAST COMMUNICATION (MULTICAST).....	20
7.4 BROADCAST	21
7.5 ANYCAST FUNCTION (ANYCAST)	21
7.6 INTRODUCTION TO ROUTING TABLE	22

7.7 ADDITIONAL HEADER INFORMATION	22
VIII. REMOTE CONFIGURATION.....	23
8.1 INTRODUCTION TO REMOTE CONFIGURATION	23
8.2 INTRODUCTION TO REMOTE SINGLE POINT CONFIGURATION	24
8.3 INTRODUCTION TO REMOTE BROADCAST CONFIGURATION	24
IX. INTRODUCTION TO THE HOST COMPUTER	25
X. HARDWARE DESIGN.....	27
XI. HARDWARE DESIGN	28
11.1 THE TRANSMISSION DISTANCE IS NOT IDEAL	28
11.2 MODULES ARE VULNERABLE TO DAMAGE.....	28
11.3 BIT ERROR RATE IS TOO HIGH	28
XII. WELDING OPERATION GUIDANCE	29
12.1 REFLOW TEMPERATURE.....	29
REVISION HISTORY	29

Disclaimer and Copyright Notice

The information in this article, including URL addresses for reference, is subject to change without notice. Documentation is provided "as is" without warranty of any kind, including any warranty of merchantability, fitness for a particular purpose, or non-infringement, and any warranty mentioned elsewhere in any proposal, specification or sample. This document disclaims all liability, including liability for infringement of any patent rights arising from the use of the information contained in this document. No license, express or implied, to the use of any intellectual property rights is granted herein by estoppel or otherwise.

The test data obtained in this article are all obtained from Ebyte laboratory testing, and the actual results may be slightly different.

All trade names, trademarks and registered trademarks mentioned in this article are the property of their respective owners and are hereby acknowledged.

The final right of interpretation belongs to Chengdu Yibaite Electronic Technology Co., Ltd.

Note: The contents of this manual may change due to product version upgrades or other reasons. Ebyte Electronic Technology Co., Ltd. reserves the right to modify the contents of this manual without any notice or prompt. This manual is only used as a guide. Chengdu Yibaite Electronic Technology Co., Ltd. makes every effort to provide accurate information in this manual. However, Chengdu Yibaite Electronic Technology Co., Ltd. does not ensure that the content of the manual is completely error-free. All statements in this manual , information and recommendations do not constitute any express or implied warranty.

I.Product Description

1.1 Product Introduction

E52-900NW22S is a wireless serial port LoRa MESH networking module based on LoRa spread spectrum technology.

The maximum output power is +10 dBm, the maximum air rate can reach 62.5 kbps, and the maximum supported baud rate is 460800 bps. The operating frequency range of the E52-900NW22S module is 903.125 - 924.125MHz (default 915.125 MHz).

E52-900NW22S adopts the new LoRa MESH networking technology, which has the functions of decentralization, self-routing, network self-healing, multi-level routing, etc. It is suitable for smart home and industrial sensors, wireless alarm security systems, building automation solutions, Smart agriculture and other application scenarios.

E52-900NW22S



1.2 Function description

The LoRa MESH network adopts a decentralized structure. The entire network is composed of only two types of nodes: terminal nodes and routing nodes. There is no need for a central node or coordinator to participate in network management; users can also build a MESH network using only routing nodes. Routing nodes are similar to terminal nodes, but terminal nodes do not have routing functions. Terminal nodes are generally deployed at the edge of the network and are generally used to design low-power nodes, but currently do not support low-power functions. Routing nodes need to continuously receive data from the network for routing updates and data forwarding, so routing nodes cannot be used as low-power nodes.

CSMA avoidance technology is adopted in the MESH network. The CSMA avoidance mechanism can prevent nodes from sending wireless data at the same time as much as possible and reduce the probability of data collision errors. The routing node will automatically collect information from surrounding nodes to form a multi-hop communication network; when a link fails or is abnormal, the routing node will re-establish a new path after several consecutive communication failures.

The network supports four communication methods, Unicast, Multicast, Broadcast and Anycast. Users can choose

different communication methods according to different application scenarios. Among them, unicast and broadcast are the simplest and most basic communication methods. In unicast mode, routes will be automatically established and request responses will be returned to determine the data transmission path; in broadcast mode, all routing nodes will start a data relay after receiving data. The multicast mechanism is relatively complex and can achieve one-to-many communication. Users need to configure the multicast group address first, similar to a public address. Anycast is usually used for data exchange between different networks. Data will not be forwarded under anycast. Under anycast, two communication methods, unicast and broadcast, can be implemented depending on the target address. Users can transmit any data to any module within the communication range.

During network transmission, data will be encrypted using special algorithms by default to ensure data privacy and security. In addition, in order to avoid data errors caused by interference from other nodes, multiple verifications are performed on the data at the network layer to ensure the reliability and accuracy of the transmitted data.

1.3 Function description

- LoRa MESH: Using advanced LoRa modulation method, it has the advantage of long-distance anti-interference, greatly improving the coverage of the entire MESH network;
- Super large network capacity: the theoretical number of LoRa MESH network is as high as 65535, and the proposed network size is about 200;
- Decentralization: The entire network is composed of only two types of nodes: terminal nodes and routing nodes, and there is no need for a central node or coordinator to participate in network management;
- Automatic routing: When initiating a data request, each routing node can automatically initiate connections with surrounding nodes to determine the data transmission path, without the need for the coordinator to participate in path planning;
- Network self-healing: When a link fails, the routing node re-establishes a new path after several communication attempts fail;
- Multi-level routing: Routing nodes can automatically transmit data to lower-level routing, and the automatically generated routing table controls the transmission direction of data;
- Path optimization: Routing information will be continuously and automatically updated and optimized with data transmission in the network to ensure the stability of the entire network;
- Avoidance mechanism: CSMA avoidance mechanism can greatly reduce the possibility of air signal collision;
- Communication methods: Supports four communication methods: Unicast, Multicast, Broadcast and Anycast;
- E52-900NW22S module frequency range: works at 903.125 - 924.125 MHz, supports 22 channels, and the channel interval is 1 MHz;
- Multiple verification: ensure the reliability and accuracy of the data transmission process;
- Multiple verification: ensure the reliability and accuracy of the data transmission process;
- High throughput: The entire network is combined in time and space to achieve high concurrency performance;
- Remote configuration: Supports remote changes of basic communication parameters of the entire network.

1.4 Network topology

LoRa MESH network supports two types of devices: routing nodes and terminal nodes.

Routing node: Routing node receives data in the network for routing updates and data forwarding.

Terminal node: Terminal nodes do not have routing functions and are generally deployed at the edge of the network.

The network topology of routing nodes and terminal nodes is as shown in the figure:

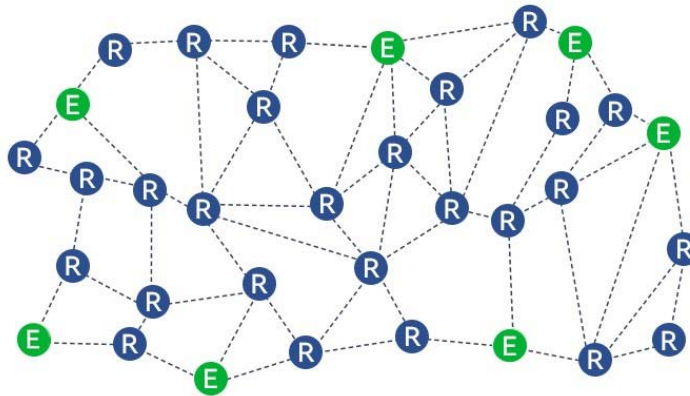

1.5 Application scenario

- Smart home and industrial sensors, etc.
- Wireless alarm security system;
- Building automation solutions;
- Smart agriculture;
- Smart logistics and warehousing.

II.Specifications

2.1 Limit parameters

The main parameters	Performance		Remark
	Minimum value	Maximum value	
Voltage	1.8V	3.6V	$\geq 3.3V$ can guarantee the output power. If it exceeds 3.6V, the module may be burned. There is no LDO inside the module. It is recommended to connect an external 3.3V LDO.
Operating temperature	-40°C	+85°C	Industrial grade design
Working humidity	10%	90%	-
Storage temperature	-40°C	+125°C	-

2.2 Working parameters

The main parameters		Performance			Remark
		Minimum value	Typical value	Maximum value	
Working voltage (V)		1.8	3.3	3.6	$\geq 3.3V$ can guarantee the output power. If it exceeds 3.6V, the module may be burned. There is no LDO inside the module. It is recommended to connect an external 3.3V LDO.
Communication level (V)			3.3		It is recommended to add level conversion when using 5.0V TTL
Working temperature (°C)		-40	-	+85	Industrial grade design
Working frequency band (MHz)		903.125	914.125	924.125	E52-900NW22S module working frequency band, supports ISM frequency band
Power consumption	Emission current (mA)	-	128	-	Instantaneous power consumption
	Working current (mA)	-	14	-	-
Transmit power (dBm)		0	9.5	10	User configurable
Over-the-air rate (bps)		7K	62.5K	62.5K	Three air speed levels are available (62.5K, 21.875K, 7K)
Receiving sensitivity (dBm)		-121	-116	-111	Sensitivity corresponding to three air speeds

The main parameters	Description	Remark
Reference distance	2.5 km	In a clear and open environment, the antenna gain is 3.0dBi, the antenna height is 2.5 meters, and the air rate is 7kbps.
	2.0 km	In a clear and open environment, the antenna gain is 3.0dBi, the antenna height is 2.5 meters, and the air rate is 21.875kbps.
	1.6 km	In a clear and open environment, the antenna gain is 3.0dBi, the antenna height is 2.5 meters, and the air rate is 62.5kbps.
Subcontracting method	200 Btye	The maximum capacity of a single package. It is prohibited to exceed the maximum capacity.
Modulation	LoRa	-
Communication Interface	UART serial port	3.3V TTL level
Packaging method	SMD type	-
Dimensions	20*14mm	±0.1mm
Antenna interface	IPEX/stamp hole	Characteristic impedance is about 50Ω
Weight	1.2g	±0.1g

III. Mechanical Dimensions and Pin Definition

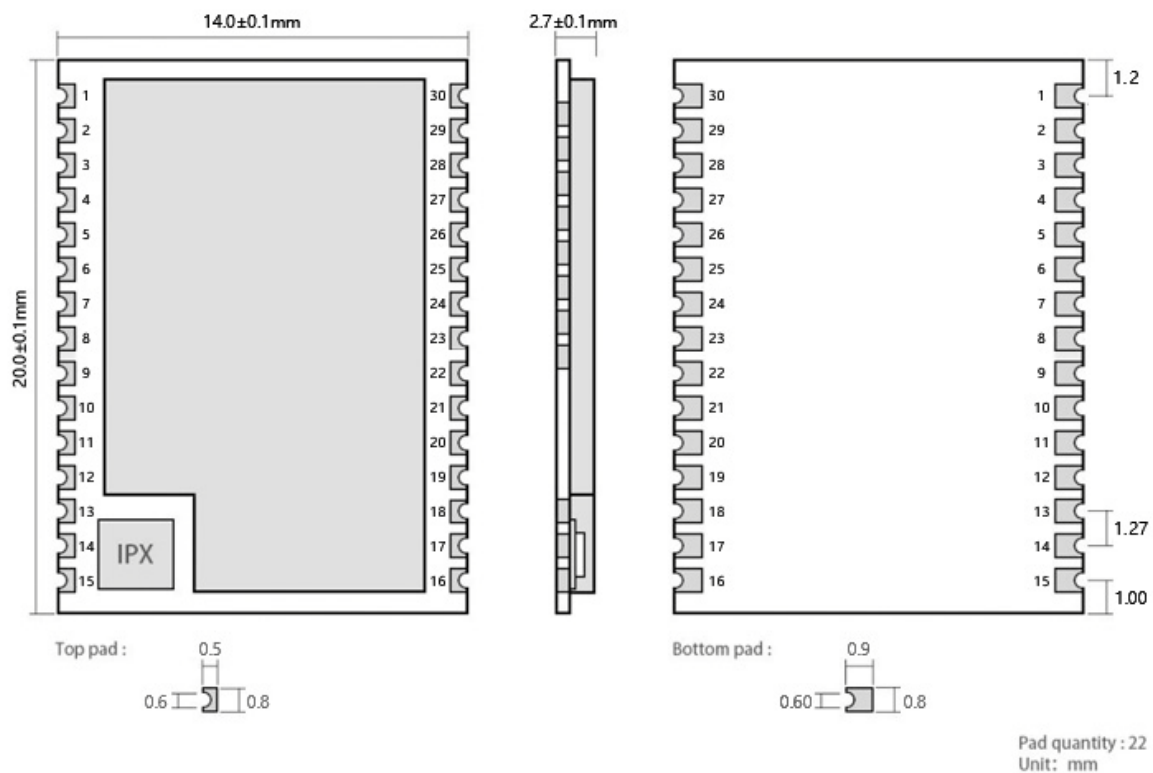

Pin number	Pin name	Pin direction	Pin usage
1	PB3	Input / Output	Some function indication pins, high level by default, active low level (connected to test suite LED2)
2	PB4	Input / Output	RF transmission indication pin, default high level, active low level (connected to test suite LED1)
3	PB5	Input / Output	Not used yet, NC recommended
4	PB6	Input / Output	Not used yet, NC recommended
5	PB7	Input / Output	Not used yet, NC recommended
6	PB8	Input / Output	Not used yet, NC recommended
7	PA0	Input / Output	Default is high level, pull it low when power on to enter the Bootloader (connected to the test suite KEY button)
8	PA1	Input / Output	Not used yet, NC recommended
9	PA2	Input / Output	UART_TXD, serial port transmit pin
10	PA3	Input / Output	UART_RXD, serial port receiving pin
11	PA4	Input / Output	Not used yet, NC recommended
12	PA5	Input / Output	Not used yet, NC recommended
13	GND	Input / Output	Ground wire, connected to the power reference ground
14	ANT	Input / Output	Antenna interface, 50Ω characteristic impedance (connected to SMA interface of test kit)
15	GND	Input / Output	Ground wire, connected to the power reference ground
16	PA8	Input / Output	Not used yet, NC recommended
17	NRST	Input	Reset pin, default high level, active low level (connected to test suite RST button)
18	PA9	Input / Output	Not used yet, NC recommended
19	PA12	Input / Output	Not used yet, NC recommended
20	PA11	Input / Output	Not used yet, NC recommended
21	PA10	Input / Output	Not used yet, NC recommended
22	PB12	Input / Output	Not used yet, NC recommended
23	PB2	Input / Output	Not used yet, NC recommended
24	PB0	Input / Output	Not used yet, NC recommended
25	PA15	Input / Output	Not used yet, NC recommended
26	PC13	Input / Output	Not used yet, NC recommended
27	GND	Input / Output	Ground wire, connected to the power reference ground
28	VDD	Input	Power supply VDD, the maximum input voltage is 3.6V, it is recommended to supply power through 3.3V LDO
29	SWDIO	-	Debug pin
30	SWCLK	-	Debug pin

IV. Recommended Connection Diagram

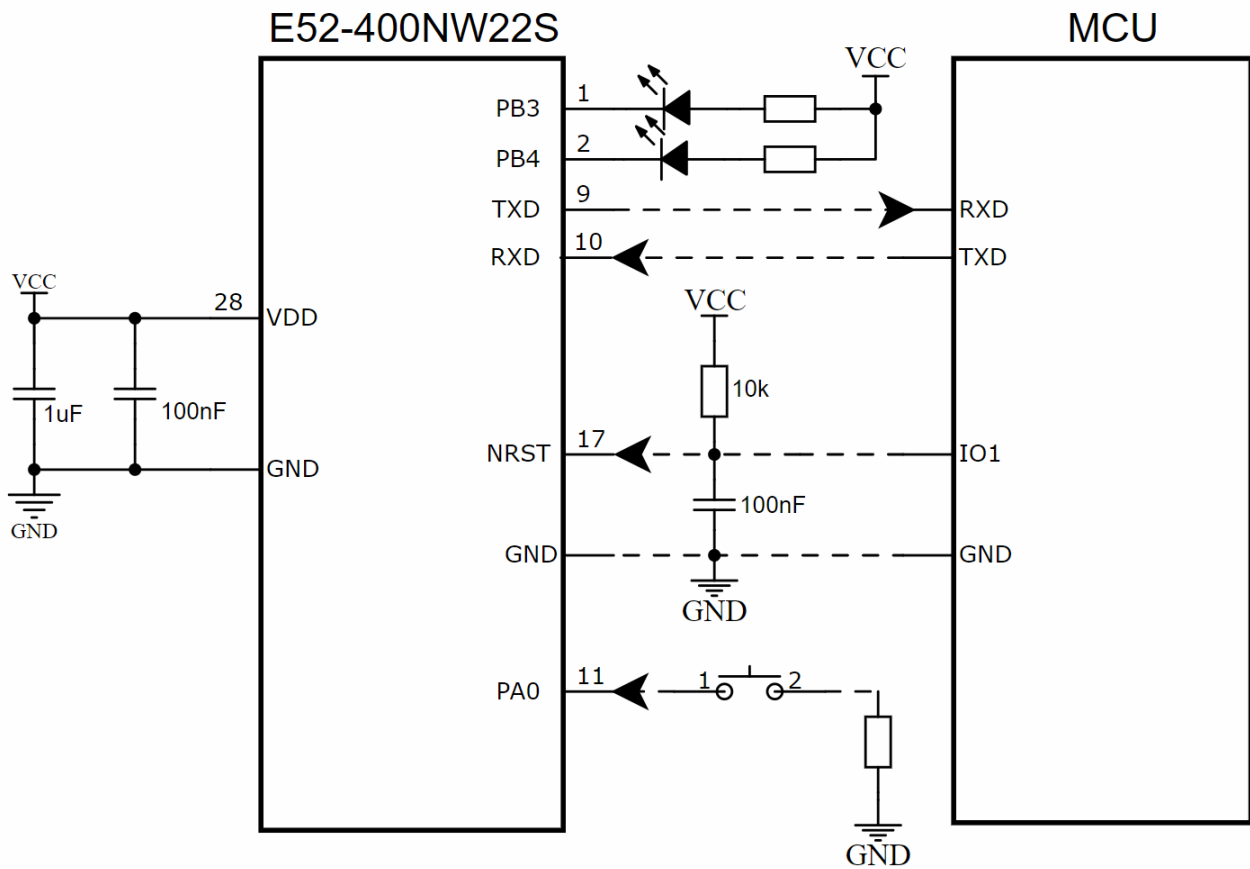

Serial number	Brief connection instructions between the module and the microcontroller (the above figure takes the STM8L microcontroller as an example)
1	The wireless serial port module is TTL level, please connect it to a 3.3V TTL level MCU.
2	When using a 5V microcontroller, please perform UART level conversion.
3	TVS protection and capacitors need to be added to the outside of the power supply (it is recommended to add a 22uF low ESR electrolytic capacitor or tantalum capacitor).
4	The RF module is sensitive to pulse static electricity. Please do not hot-swap the module.
5	There is no LDO inside the module. It is recommended to connect an external 3.3V LDO for power supply.

V. Test Suite

5.1 Test Suite Introduction

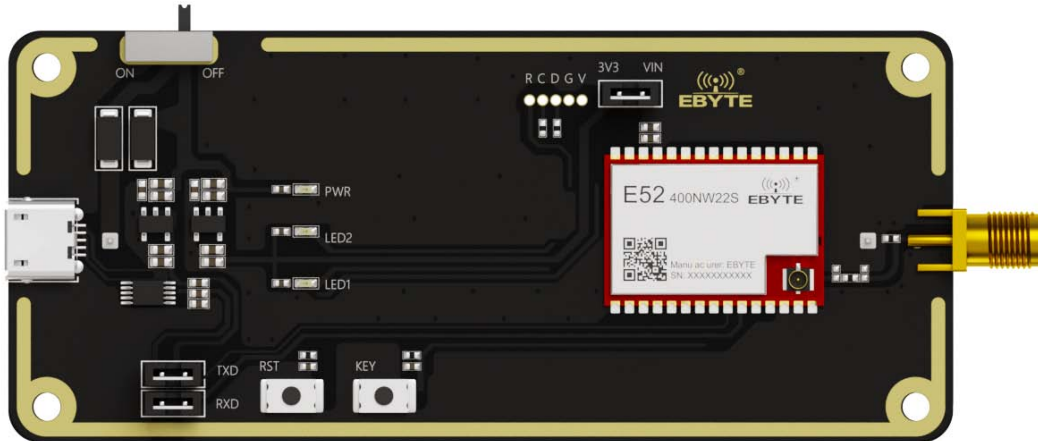

Figure 5.1.1 Physical Object

- The E52-900NW22S-TB test kit is designed to help users quickly evaluate module-related functions. For first-time use, it is recommended to purchase several test kits directly for testing (the test kit has been soldered with the E52-900NW22S module).
- The hardware integrates power supply circuit, reset circuit, button circuit, power indicator light PWR, work indicator LED, etc., and an 18650 battery box is reserved at the bottom. Customers can install 18650 batteries by themselves for testing.
- The test kit has connected the required pins of the module to the corresponding peripherals, the most important of which is the TTL to USB circuit. Users only need to connect the Micro USB to the computer, and a COM port will appear on the computer's device manager.
- If you do not see the corresponding COM, there may be the following possibilities:
 - The CH340 driver is being installed automatically, please wait patiently for a while; if the driver cannot be installed automatically, you need to install it manually.
 - Check whether the module power light PWR is on and whether the module is supplying power normally?
- Download any serial port debugging tool. Under the relevant downloads on the official website, there is the XCOM serial port debugging assistant;
- Open the serial port debugging assistant, follow the above steps to simply set up the software, and send "AT+INFO=?" to read the module-related parameters.

VI. Command Introduction

6.1 Introduction to AT commands

- AT instructions are divided into three categories: command instructions, setting instructions and query instructions;
- AT command uses 115200 bps baud rate by default, without sending new lines;
- Different AT commands require different numbers of input parameters. Different parameters need to be separated by ",". The input parameters are uniformly decimal values. You need to read the instruction set carefully for details. If the number of input parameters of the AT command is wrong, the serial port will Returns data similar to "AT+DST_ADDR=CMD_ERR".
- Some AT command parameters will be restricted. If the AT command input value is wrong, the serial port will return data similar to "AT+DST_ADDR=CMD_VALUE_ERR";
- If the parameter setting is successful, the serial port will return data similar to "AT+DST_ADDR=OK";
- Data in non-AT command sets will be considered transparent data, and the module will initiate a data request, so you should try to avoid sending data starting with "AT+";
- After using the saved instructions, all parameters inside the current module will be saved. Most of the setting instructions will be saved directly to Flash. Only some common setting instructions can be saved to Flash according to the parameters.

6.2 Command instruction set

- The command instruction has no suffix, and only requires "AT+RESET" to restart the module.

Command Instruction	Function	Description
AT+IAP	Enter IAP upgrade mode	After returning AT+IAP=OK, the module immediately restarts and enters the IAP upgrade mode. It remains powered on for about 30 seconds and automatically exits the IAP upgrade mode.
AT+RESET	Module restart	After returning AT+RESET=OK, the module will restart immediately.
AT+DEFAULT	Restore module to factory settings	After returning AT+DAFAULT=OK, the parameters will be restored to factory values, and then restart immediately.

6.3 Query instruction set

- The suffix of the query command is "=?". For example, the query module related information command "AT+INFO=?", the module will return the main parameters of the module.

Query command	Function	Description
AT+INFO=?	Query the main parameters of the module	Important command, returns the main parameters of the module (displayed and used by the serial port assistant)
AT+DEVTYPE=?	Query module model	Return the device model such as E52-900NW22S
AT+FWCODE=?	Query module firmware code	Return the firmware code such as 7460-0-10
AT+POWER=?	Query module transmit power	Returns RF output power
AT+CHANNEL=?	Query module working channel	Return to RF working channel
AT+UART=?	Query module serial port parameters	Returns the serial port baud rate and check digit
AT+RATE=?	Query module air rate	Return module air rate [0:62.5K 1:21.825K 2:7K]
AT+OPTION=?	Query module communication method	Important command, return module communication method
AT+PANID=?	Query network identification code	Return network identifier
AT+TYPE=?	Query the node type of the module	Return module type (routing node/terminal node)
AT+SRC_ADDR=?	Query the address of the current module	Important instruction, returns the address of the current module
AT+DST_ADDR=?	Query the address of the target module	Important instruction, returns the address of the target module
AT+SRC_PORT=?	Query the port of the current module	Returns the port of the current module
AT+DST_PORT=?	Query the port of the target module	Returns the port of the target module
AT+MEMBER_RAD=?	Query multicast member radius	Returns the propagation radius of multicast members. The larger the radius, the greater the coverage.
AT+NONMEMBER_RAD=?	Query multicast non-member radius	Returns the multicast non-member propagation radius. The larger the radius, the greater the coverage.
AT+CSMA_RNG=?	Query CSMA random avoidance time	Returns the maximum random avoidance time

AT+ROUTER_SCORE=?	Maximum number of consecutive route query failures	Returns the maximum number of consecutive failures. If this number is exceeded, routing information will be removed.
AT+HEAD=?	Query whether the extra frame header function is enabled	Returns whether the extra frame header function is enabled
AT+BACK=?	Example Query whether the function of sending return messages is enabled	Return Whether the function of sending return messages is enabled
AT+SECURITY=?	Query whether the data encryption function is enabled	Returns whether the data encryption function is enabled
AT+RESET_AUX=?	Query whether LED2 changes during automatic reset	Returns whether LED2 changes to turn on when the radio frequency is restarted.
AT+RESET_TIME=?	Query the automatic reset time	Returns the radio frequency automatic restart time, unit min
AT+FILTER_TIME=?	Query broadcast filter timeout	Returns the broadcast filter timeout
AT+ACK_TIME=?	Query request response timeout	Return request response timeout
AT+ROUTER_TIME=?	Query routing request timeout	Returns the routing request timeout
AT+GROUP_ADD=?	Query GROUP information	Return multicast group address table
AT+GROUP_DEL=?		
AT+GROUP_CLR=?		
AT+ROUTER_CLR=?	Query routing table information	Return routing table information
AT+ROUTER_SAVE=?		
AT+ROUTER_READ=?		
AT+MAC=?	Query MAC unique address	Returns the MCU's unique 32-bit MAC address
AT+KEY=?	Query encryption key	Unable to read to avoid key leakage

6.4 Setting up the instruction set

- Set the command suffix to "=%d,%d,%d", for example, set the module target address command "AT+DST_ADDR=25640,0", the first parameter is the target address, and the second parameter is whether to save to Flash, the middle needs to be separated by ",".
- If there is no <save> parameter in the setting command, it will be saved in Flash.

Setup instructions	Function	Description
AT+INFO=0	Query module advanced parameters	Return to the module for more advanced setting parameters (displayed using the serial port assistant)
AT+POWER=<power>,<save>	Set module transmit power	<power>: RF output power (-9 ~ +22 dBm) <save>: whether to save to Flash
AT+CHANNEL=<channel>,<save>	Set module working channel	<channel>: E52-900NW22S frequency band: RF working channel (0 ~ 79) <save>: whether to save to Flash
AT+UART=<baud>,<parity>	Set module serial port parameters	Restart takes effect <baud>: serial port baud rate (1200 ~ 460800) <parity>: Check digit (8N1 8E1 8O1)
AT+RATE=<rate>	Set module air rate	<rate>: 0:62.5K 1:21.825K 2:7K
AT+OPTION=<option>,<save>	Set module communication method	Commonly used instructions, generally broadcast and unicast <option>: Communication method (1 ~ 4) <save>: whether to save to Flash
AT+PANID=<panid>,<save>	Set network ID	Commonly used instructions, it is not recommended to use the default value <panid>: network identification code (0 ~ 65535) <save>: whether to save to Flash
AT+TYPE=<type>	Set the node type of the module	<type>: 0: routing node 1: terminal node
AT+SRC_ADDR=<addr>,<save>	Set the address of the current module (Guaranteed uniqueness)	Commonly used commands, the default is the last 15 digits of the MAC address <addr>: current address (0 ~ 65535) <save>: whether to save to Flash
AT+DST_ADDR=<addr>,<save>	Set the address of the target module	Commonly used instructions to set the target address <addr>: target address (0 ~ 65535) <save>: whether to save to Flash

AT+SRC_PORT=<port>,<save>	Set the port of the current module	<port>: Default current port 1 <save>: whether to save to Flash
AT+DST_PORT=<port>,<save>	Set the port of the current module	<port>: Default target port 1 <save>: whether to save to Flash
AT+MEMBER_RAD=<rad>,<save>	Set module multicast member radius	For multicast use, it is recommended to keep the default <rad>: multicast member radius (0 ~ 15) <save>: whether to save to Flash
AT+NONMEMBER_RAD=<rad>,<save>	Set module multicast non-member radius	For multicast use, it is recommended to keep the default <rad>: Multicast non-member radius (0 ~ 15) <save>: whether to save to Flas
AT+CSMA_RNG=<rng>	Set CSMA random avoidance time	it is recommended to keep the default Random avoidance time range (20 ~ 65535) ms
AT+ROUTER_SCORE=<score>	Set the maximum number of consecutive routing failures	<score>: The maximum number of consecutive route failures, Routes need to be re-established after exceeding
AT+HEAD=<enable>	Set the extra frame header function enable switch	<enable>: Whether the extra frame header function is enabled
AT+BACK=<enable>	Example Set the function of sending return messages	<enable>: Send return information Whether the function is enabled
AT+SECURITY=<enable>	Set the data encryption function enable switch	<enable>: Whether the data encryption function is enabled
AT+RESET_AUX=<enable>	Set auto-reset LED2 change switch	<enable>: Automatic reset LED2 change enable
AT+RESET_TIME=<reset_time>	Set automatic reset time	<reset_time>: automatic reset interval time (min)
AT+FILTER_TIME=<time>	Set broadcast filter timeout	it is recommended to keep the default <time>: Broadcast filter timeout (3000 ~ 65535 ms)
AT+ACK_TIME=<time>	Set request response timeout	it is recommended to keep the default <time>: Request response timeout (1000 ~ 65535 ms)
AT+ROUTER_TIME=<time>	Set routing request timeout	it is recommended to keep the default <time>: Routing request timeout (1000 ~ 65535 ms)
AT+GROUP_ADD=<gruop>	Add GROUP information	<group>: Add multicast group address, up to 8 can be added

AT+GROUP_DEL=<group>	Delete GROUP information	<group>: Delete multicast group address
AT+GROUP_CLR=<enable>	Delete GROUP information table	<enable>: 1: Delete the entire GROUP information table
AT+ROUTER_CLR=<enable>	Clear routing table information	<enable>: 1: Delete the entire routing information table
AT+ROUTER_SAVE=<enable>	Flash operation of routing table	<enable>: 1: Save routing information table to Flash <enable>: 0: Delete the routing information in Flash
AT+ROUTER_READ=<enable>	Read routing information in Flash	<enable>: 1: Load the routing information table in Flash
AT+KEY=<key>	Set data encryption key	Communication is impossible if the keys are different <key>: Data encryption key [0~0x7FFF FFFF]

6.5 Parameter value table

Parameter name	Value range	Function	Description
<save>	[0~1]	Whether parameters are saved to Flash	[1: Save, 0: Do not save]
<power>	[0~10]	Set module transmit power	RF output power [0~+10] dBm
<channel>	[0~21]	Set the working channel of the E52-900NW22S module	Working channel [0~21], Corresponding frequency 903.125 ~913.125 MHz Operating frequency =913.125 + channel * 1 MHz
<baud>	See description	Set baud rate	It will take effect after restarting, and the following baud rates are supported: 1200,2400,4800,9600,19200,38400, 57600,115200,230400,460800 bps
<parity>	[0~2]	Set check digit	Serial port check digit [0:8N0 1:8E1 2:8O1]
<rate>	[0~3]	Set air rate	[0:62.5K 1:21.825K 2:7K]
<option>	[1~4]	Set communication method	Communication method [1: Unicast 2: Multicast 3: Broadcast 4: Anycast]

<panid>	[0~65534]	Set network ID	Network identification code [0x0000~0xFFFE]
<type>	[0~1]	Set the node type of the module	Set the node type of the module [0: Routing node 1: Terminal node]
<addr>	[0~65534]	Set module address	Address range [0x0000~0xFFFE] Routing node: 0x0000~0x7FFF Terminal node: 0x8000~0xFFFE
<group>	[0~65534]	Set multicast group address	Group address range [0x0000~0xFFFE]
<port>	[1、14]	Port settings	Different ports correspond to different functions, and the remaining ports have no functions yet. Port 1: Output data directly through UART Port 14: Parse data as AT commands
<rad>	[0~15]	Set the propagation radius under multicast	Multicast propagation radius[0~15] The larger the radius, the greater the number of propagation stages.
<rng>	[20~65535]	Set CSMA random avoidance time	Random avoidance time [20~65535] ms
<score>	[1~15]	Set the maximum number of consecutive failures,Exceeding this will require re-initiating the routing request	Maximum number of consecutive failures [1~15]
<enable>	[0~1]	Various function switches	[1: Function enabled 0: Function disabled]
<reset_time>	[0~255]	Automatic reset RF time	Automatic reset time [1~255] min [0: Turn off automatic reset]
<time>	See description	Network timeout	Broadcast filter timeout [3000~65535] ms Request response timeout [1000~65535] ms Routing request timeout [1000~65535] ms
<key>	[0~0x7FFF FFFF]	Network encryption key	Encryption key [0~0x7FFF FFFF]

6.6 Parameter Notes

- If the setting command does not have the **save option <save>** parameter, it will be saved in Flash.
- After the **baud rate <baud>** and **parity bit <parity>** are set, a **reboot** is required to take effect. You can use "AT+RESET" to reset.
- **Address <addr>** and **network identification code <panid>** are generally not recommended to be set to 0xFFFF. 0xFFFF is used as a broadcast address and broadcast network.
- **Node type <type>** will change the highest bit of the local address. Generally, you need to set the **node type <type>** after setting the **local address <addr>**.
- **generally keeps the default port 1**. Only in remote configuration, the target port needs to be changed to port 14, and the other ports have no function yet.
- **Multicast radius <rad>** is generally **kept at the default level 2**. The larger the **multicast radius <rad>** is, the larger the coverage area is.
- **CSMA random avoidance time<rng>** **generally keeps the default value of 127 (random avoidance time is 0~127ms)**. The longer the random avoidance time, the slower the network response speed, but the lower the possibility of conflict. If you want to modify this time, you need to pay attention to the response time and conflict probability of the entire network. **It is generally not recommended to shorten this time**.
- **The maximum number of consecutive failures <score>** is **generally kept at the default value of 3**. **The maximum number of consecutive failures <score>** will affect the probability of re-establishing routes.
The smaller the maximum number of consecutive failures <score> is, the shorter the time it takes to re-establish the route when a link fails or the communication is abnormal. However, re-establishing the route takes a certain amount of time, so it is generally sufficient to keep the default. When communication is successful, the current number of failures will be reset.
- **The RF automatic reset time <reset_time>** **generally keeps the default value of 5 minutes**. When data is received, the radio frequency automatic reset time will be reset, which will not affect normal data transmission. This time can be shortened in places with severe environmental interference. Setting it to 0 minutes will turn off the automatic restart function.
- **The default values of broadcast filter timeout <time>** at different airspeeds are 15s, 30s, and 60s respectively. When duplicate data frames are received within the **broadcast filtering timeout <time>**, they will be filtered. **It is not recommended to shorten this time**.
- **The default values of request response timeout <time>** at different airspeeds are 2.5s, 5s, and 15s respectively.
 NO ACK Under unicast, the target device needs to return a response ACK. If it gets a response ACK from the target address, it will return SUCCESS immediately. Otherwise, it will wait for the **request response timeout <time>** to end before returning NO ACK.
 The more levels of routing devices passed through, the longer **the request response timeout <time>** should be. Under the default parameters, about 5 levels of routing devices can be supported.
- **The default values of routing request timeout <time>** at different airspeeds are 2.5s, 5s, and 15s respectively.
 Under unicast, you need to initiate a routing request first, collect the routing information of each device within **the routing request timeout <time>**, and then initiate another data request after the end.
The routing request timeout <time> needs to cover the entire process from the initiation of the routing request to the complete completion of the network. If the route is not successfully established, NO ROUTER will be returned.
 The greater the number of devices, the longer **the routing request timeout <time>** should be. Under the default parameters, about 50 devices can be supported to establish routes. More than 50 devices need to extend this time through instructions.

- When "OUT OF CACHE" is returned, it means that the sending buffer is full. The sending buffer area can cache 5 items. Under normal circumstances, the buffer area will not be full. It will only occur when the interval between consecutive sendings is too fast, and all sending data buffers will be forcibly cleared inside the module.
- The network protocol layer uses data RSSI to optimize the entire network link. The routing nodes will automatically select the best routing nodes for routing. Users no longer need to consider signal strength.

VII. Basic Function Introduction

7.1 Get the main parameters of the module

- The main parameters of the module can be obtained through the "AT+INFO=?" AT command. It is mainly used for serial port display, as shown in Figure 8.1.1.
- If it is difficult to use the MCU to parse it, the correct operation of the MCU should be obtained using a separate AT command, as shown in Figure 8.1.2.

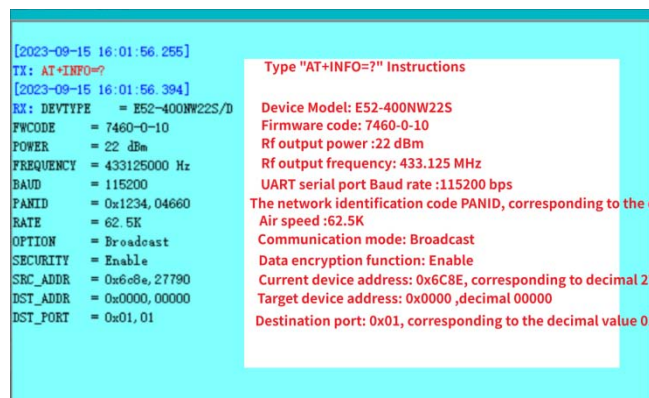

Figure 8.1.1 AT+INFO=? command

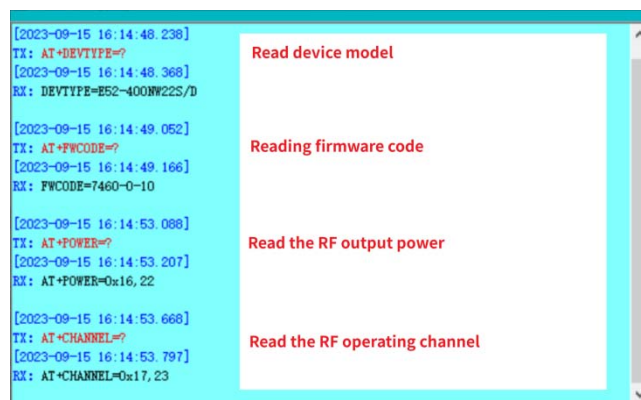

Figure 8.1.2 MCU obtains parameters

7.2 Unicast communication (Unicast)

- Unicast communication method requires knowing the address of the target module (the address of module B) in advance. Please refer to Chapter 8.1 for the specific steps to obtain basic parameters.
- When initiating a unicast request for the first time, you need to wait for route establishment (the waiting time is different under different airspeeds). After the route establishment is completed, the module will automatically send user data 1234567890 again. After the route is established, access again does not need to wait for the route to be re-established until the number of consecutive communication failures with a node exceeds 3 times.
- The routing table can be queried through the "AT+ROUTER_CLR=?" command.
- The data frame header can be closed using the "AT+HEAD=0" command.
- User data cannot be module internal AT commands, otherwise they will be recognized by the module as AT commands, resulting in user data being unable to be sent.
- The basic operation steps of unicast are as follows:

Step 1: Module A uses the "AT+DST_ADDR=26034,0" command to configure the target address as the address of module B;

Step 2: Module A uses the "AT+OPTION=1,0" command to change the communication mode to unicast mode (Unicast);

Step 3: Module A sends user data 1234567890. If the transmission is successful, SUCCESS will be returned; if the transmission fails, NO ROUTE or NO ACK will be returned. NO ROUTE means that the route establishment failed; NO ACK means that the route was established successfully but no response was received. If NO ACK occurs three times, the routing table needs to be re-established.

Step 4: Module B receives the (ASCII code) 1234567890 sent from module A and converts it into HEX format as 31 32 33 34 35 36 37 38 39 30 (showing different encoding), and adds additional data frame headers.

- The time for first initiating a unicast request is different under different airspeeds, which is at least 1.5 routing request timeouts:

It takes about 4 seconds to initiate a unicast request for the first time at 62.5K airspeed.

It takes about 8 seconds to initiate a unicast request for the first time at 21.875K airspeed.

It takes about 25 seconds to initiate a unicast request for the first time at 7K airspeed.

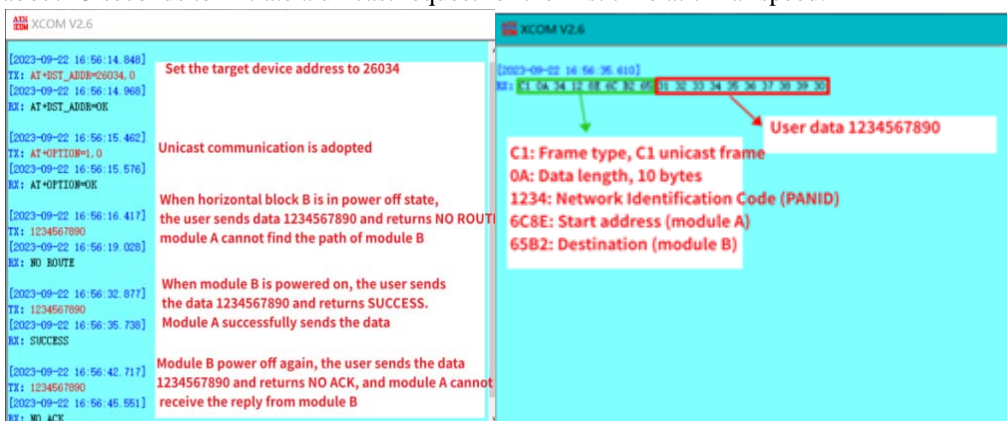

Figure 8.2.1 Unicast communication

7.3 Multicast communication (Multicast)

- Multicast (multicast) communication method requires group management of target modules in advance. All target modules need to be grouped in advance using "AT+GROUP_ADD=<group>".
- <group> can be understood as a public address, and each module can set up to 8 group addresses.
- In multicast mode, routing needs to be re-established every time. It is recommended that the interval between consecutive multicast initiations be about 5 seconds.
- "AT+GROUP_DEL=<group>" can delete the group address with the public address group and save the new group information to Flash.
- "AT+GROUP_CLR=1" can clear all group addresses and also clear the group information in Flash.
- The routing table can be queried through the "AT+ROUTER_CLR=?" command.
- The data frame header can be closed using the "AT+HEAD=0" command.
- The user data cannot be an internal AT command of the module, otherwise it will be recognized by the module as an AT command, resulting in the inability to send user data.

- The basic operation steps of multicast (multicast) are as follows:
 - Step 1: Use "AT+GROUP_ADD=123" for module B in advance to set the group;
 - Step 2: Module A uses the "AT+OPTION=2,0" command to change the communication mode to multicast mode (Multicast);
 - Step 3: Module A uses the "AT+DST_ADDR=123,0" command to change the communication mode to multicast mode and set the target group address;
 - Step 4: Module A sends user data 1234567890. If the transmission is successful, SUCCESS will be returned; if the transmission fails, NO ROUTE or NO ACK will be returned. NO ROUTE means that the route establishment failed; NO ACK means that the route was established successfully but no response was received. If NO ACK occurs three times, the routing table needs to be re-established.
 - Step 5: Module B receives the (ASCII code) 1234567890 sent from module A and converts it into HEX format as 31 32 33 34 35 36 37 38 39 30 (showing different encoding), and adds additional data frame headers.

- The time for first initiating a unicast request is different under different airspeeds, which is at least 1.5 routing request timeouts:
 - It takes about 4 seconds to initiate a unicast request for the first time at 62.5K airspeed.
 - It takes about 8 seconds to initiate a unicast request for the first time at 21.875K airspeed.
 - It takes about 25 seconds to initiate a unicast request for the first time at 7K airspeed.

7.4 Broadcast

- The broadcast communication method does not require knowing the address of the target module.
- There is no sending timeout under the broadcast module, and there is no need to establish a route, but all receiving modules will forward the data again after receiving it. The module's built-in CSMA avoidance mechanism and broadcast filtering mechanism can effectively prevent data collision and secondary forwarding.
- User data cannot be module internal AT commands, otherwise they will be recognized by the module as AT commands, resulting in user data being unable to be sent.
- The basic operation steps of broadcasting are as follows:
 - Step 1: Module A uses the "AT+OPTION=3,0" command to change the communication mode to broadcast mode (Broadcast);
 - Step 2: Module A sends user data 1234567890. Successfully sent will return SUCCESS, the user can wait for SUCCESS to determine whether the data is sent successfully;
 - Step 3: Module B received the (ASCII code) 1234567890 sent from module A and converted it into HEX format as 31 32 33 34 35 36 37 38 39 30 (showing different encoding), and added additional data frame headers.

7.5 Anycast function (Anycast)

- Anycast communication is generally used for communication between different networks, and different networks have different network identification codes. Unicast, multicast, and broadcast communication methods cannot directly interact with data between networks. In this case, anycast can be used to interact with data between different networks.
- Anycast communication can send data to a single or all nodes within the single-hop coverage according to the set target address.
- Data cannot be relayed and responded to in anycast mode.
- Anycast cannot guarantee the reliability of data transmission, similar to simple data transparent transmission.
- User data cannot be module internal AT commands, otherwise they will be recognized by the module as AT commands, resulting in user data being unable to be sent.
- The basic operation steps of anycast are as follows:
 - Step 1: Module A uses the "AT+DST_ADDR=26034,0" command to configure the target address as the address of module B;
 - Step 2: Module A or use the "AT+DST_ADDR=65535,0" command to configure the target address to all modules;
 - Step 3: Module A uses the "AT+OPTION=4,0" command to change the communication mode to anycast mode (Anycast);
 - Step 4: Module A sends user data 1234567890. If the transmission is successful, SUCCESS will be returned. The user can wait for SUCCESS to determine whether the data is sent successfully;
 - Step 5: Module B receives the (ASCII code) 1234567890 sent from module A and converts it into HEX format as 31 32 33 34 35 36 37 38 39 30 (showing different encoding), and adds additional data frame headers.

7.6 Introduction to routing table

- The routing table is automatically established by routing requests and cannot be modified manually. It is stored in RAM and will be lost if the module is restarted. The routing table is only for viewing paths. Users do not need to pay attention to it. There is no need to parse AT commands on the routing table.
- The routing table can be saved to Flash through the "AT+ROUTER_SAVE=1" command, and can be loaded through the "AT+ROUTER_READ=1" command when powering on again.
- If you want to clear the routing information saved in Flash, you can clear it through the "AT+ROUTER_SAVE=0" command.
- If you only want to clear the routing information in RAM, you can clear it through the "AT+ROUTER_CLR=1" command.
- The routing table can be read through the three instructions "AT+ROUTER_CLR=?", "AT+ROUTER_SAVE=?", and "AT+ROUTER_READ=?".
- The routing table contains parameters such as target address, lower-level address, score, signal strength, etc.
- When the DST and HOP in the routing table are different, it means that the module needs to pass through the routing node to reach the target module.
- The routing information of NO.03 and NO.04 in the figure below together form a path to the target address 59020: The routing information of NO.04 tells the module that if it wants to send data to the module of 59020, the next level should send the data through the routing node of 26017. The routing information of NO.03 tells the module that if it wants to send data to the module of 26111, the next level can directly transmit the data to the routing node of 26111.

7.7 Additional header information

- When the module receives data from other modules, additional frame header information will be added to the serial port output data.
- Frame header meaning:

Frame type	Data length	Network ID	Initial address	Target address	User data
C1	03	34 12	8E 6C	28 64	01 02 03
C3	01	34 12	AA 71	28 64	AA

- Frame type: C1 represents unicast frame, C2 represents multicast frame, C3 represents broadcast frame, C4 represents anycast frame;
 - Data length: user data length, maximum value 200 bytes;
 - Network identification code: Different networks have different network identification codes. This information can be used to know which network the source is;
 - Address: Specifies the source and destination of data;
 - User data: User data area, maximum 200 bytes.
- The address and network identification in the data frame header are low-order first, such as network identification 34 12, which should actually be 0x1234, making it easier to use the structure to parse it.
 - The data frame header can be turned off through the "AT+HEAD=0" command.

VIII. Remote Configuration

8.1 Introduction to remote configuration

- In addition to basic communication, the module also supports remote configuration functions. Since remote configuration can change the basic communication parameters of the entire network, it needs to be used with caution to avoid changing important parameters of some nodes and preventing normal communication with the previous network.
- Remote configuration can be divided into two types: single-point configuration and broadcast configuration. In both configuration modes, the instruction will be executed after a certain period of delay. The purpose is to maintain the current parameters and continue to forward the data to the next-level module to ensure that the data can be transmitted to the entire network and then take effect.
- In single-point configuration, routing also needs to be established in advance. When the target receiving module receives the correct AT command, it will return "+OK" or "+FAIL" through the radio frequency to indicate the module execution result. Under broadcast configuration, it is still the same as basic broadcast communication. All modules that receive data will forward the data once to ensure that modules in the entire network can receive this instruction. However, under broadcast configuration, there will be no radio frequency data response.
- The default target port used for normal basic communication is port 1. The corresponding function is to output the data sent by the user directly through the serial port and add additional information frame headers. The target port used for remote configuration is port 14. The corresponding function is to parse the remote configuration instructions sent by the user and delay execution or response after a period of time. The remote configuration command needs to be additionally added with "++" to distinguish it from the local configuration. After the remote configuration is completed, the target port should be restored to port 1 in time to avoid affecting the next basic communication.
- The delay time is different under different airspeeds. The specific delay time is as follows (a route establishment timeout time):
 - The command delay execution time at 62.5K airspeed is about 2.5 seconds.
 - The command delay execution time is about 5 seconds at 21.875K airspeed.
 - The command delay execution time is about 15 seconds at 7K airspeed.

8.2 Introduction to remote single point configuration

- The basic steps for remote single-point configuration are as follows:
 - Step 1: Module A uses the "AT+DST_ADDR=26034,0" command to configure the target address as the address of module B;
 - Step 2: Module A uses the "AT+OPTION=1,0" command to change the communication mode to unicast mode (Unicast);
 - Step 3: Module A uses the "AT+DST_PORT=14,0" command to modify the target port to the remote parsing AT command function;
 - Step 4: Module A sends the AT command "+AT+PANID=4660,0". If sent successfully, SUCCESS will be returned;
 - Step 5: After receiving the instruction, module B will output the execution result of the corresponding instruction through the serial port after waiting for a route establishment timeout, and respond with "+OK:" or "+FAIL:" through the radio frequency, and will send the current module The parameters are sent via radio frequency, and SUCCESS will be returned if the transmission is successful;
 - Step 6: Module A receives the module information responded from module B and outputs it through the serial port.

8.3 Introduction to remote broadcast configuration

- The basic steps for remote broadcast configuration are as follows:
 - Step 1: Module A uses the "AT+OPTION=3,0" command to change the communication mode to broadcast mode (Broadcast);
 - Step 2: Module A uses the "AT+DST_PORT=14,0" command to modify the target port to the remote parsing AT command function;
 - Step 3: Module A sends the AT command "+AT+PANID=4660,0". If sent successfully, SUCCESS will be returned;
 - Step 4: After receiving the instruction, module B waits for a route establishment timeout period and then outputs the execution result of the corresponding instruction through the serial port.

IX. Introduction to the host computer

- Users can use the host computer provided by the official website to configure the module. When using it, the user needs to virtualize the module serial port into a COM port. The host computer interface is as shown below. The upper part is the basic function buttons to set the COM port, baud rate, and calibration. By checking the bit, you can perform operations such as parameter reading, writing, restoring defaults, and restarting the module. The lower left side is the parameter area. The right side below is the log area, which will print and display the corresponding AT commands executed. Users can operate the module based on the logs.



- The second page is the multicast-related group address settings. Users can add, delete and query multicast group addresses. The multicast group address supports up to 8 different addresses. .

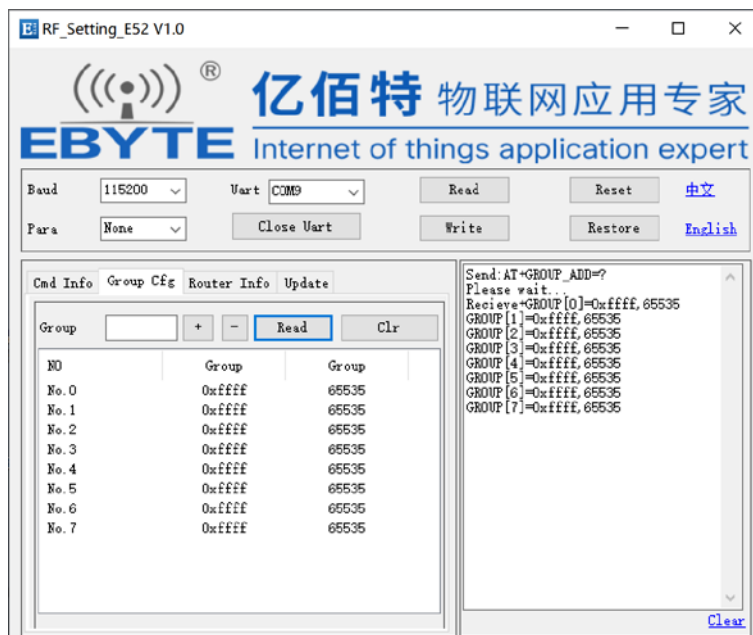

- The third page is the routing table-related functions. Users can read and clear the routing table, and can also perform Flash-related read and write operations. Due to the huge amount of data, it takes about 4 seconds to read the routing table. If there is no routing table information, the error "read error or null" will be returned.
- The routing table will continuously update the path according to the data transmitted in the network to optimize network transmission efficiency.
- It is not recommended to read the routing table at low baud rates such as 1200, 2400, 4800, etc., as it will take a long time.



- The fourth page is the online upgrade (IAP) function. Users can upgrade the firmware. **Under normal circumstances, there is no need to upgrade.** If you accidentally enter the IAP upgrade mode and keep powering on for about 30 seconds, the module will automatically exit the IAP upgrade mode and will not exit the IAP upgrade mode even if it is restarted.

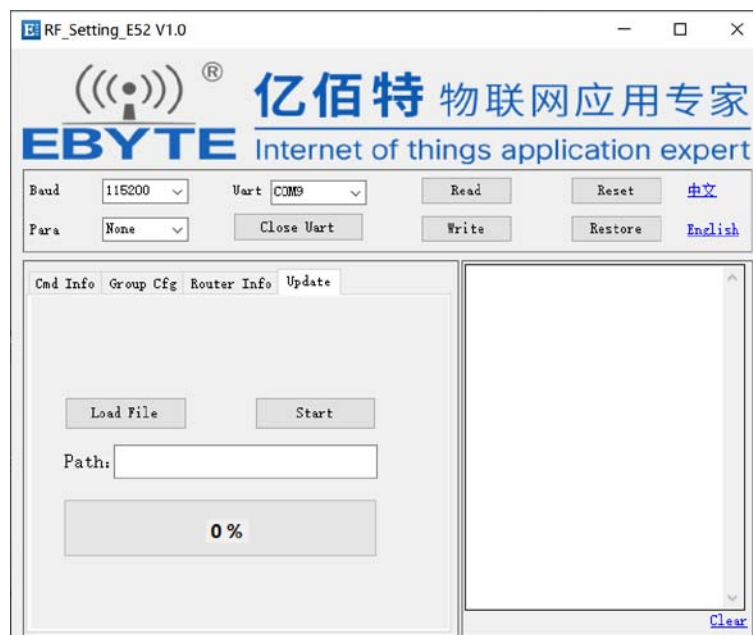

X. Hardware Design

- It is recommended to use a DC regulated power supply to power the module. The power ripple coefficient should be as small as possible, and the module must be reliably grounded;
- Please pay attention to the correct connection of the positive and negative poles of the power supply. Reverse connection may cause permanent damage to the module;
- Please check the power supply to ensure that it is within the recommended power supply voltage. If it exceeds the maximum value, it will cause permanent damage to the module;
- Please check the stability of the power supply. The voltage cannot fluctuate greatly and frequently;
- When designing the power supply circuit for the module, it is often recommended to reserve more than 30% margin, so that the whole machine can work stably for a long time;
- The module should be kept as far away as possible from power supplies, transformers, high-frequency wiring and other parts with high electromagnetic interference;
- High-frequency digital traces, high-frequency analog traces, and power traces must be avoided under the module. If it is absolutely necessary to pass under the module, assume that the module is welded on the Top Layer, and ground copper is laid on the Top Layer of the module contact part (all paved Copper and well grounded), must be close to the digital part of the module and routed on the Bottom Layer;
- Assuming that the module is welded or placed on the Top Layer, it is also wrong to route traces randomly on the Bottom Layer or other layers, which will affect the spuriousness and receiving sensitivity of the module to varying degrees;
- Assuming that there are devices with large electromagnetic interference around the module that will greatly affect the performance of the module. It is recommended to stay away from the module according to the intensity of the interference. If the situation allows, appropriate isolation and shielding can be done;
- Assuming that there are traces with large electromagnetic interference around the module (high-frequency digital, high-frequency analog, power traces), which will also greatly affect the performance of the module. According to the intensity of the interference, it is recommended to stay away from the module appropriately. This can be done if the situation allows Proper isolation and shielding;
- If the communication line uses 5V level, a 1k-5.1k resistor must be connected in series (not recommended, there is still a risk of damage);
- Try to stay away from some TTL protocols whose physical layer is also 2.4GHz, such as USB3.0;
- The antenna installation structure has a great impact on module performance. Make sure the antenna is exposed and preferably vertically upward;
- When the module is installed inside the casing, you can use a high-quality antenna extension cable to extend the antenna to the outside of the casing;
- The antenna must not be installed inside a metal shell, as this will greatly reduce the transmission distance.

XI. Hardware Design

11.1 The transmission distance is not ideal

- When there are straight-line communication obstacles, the communication distance will be correspondingly attenuated;
- Temperature, humidity, and co-channel interference will lead to increased communication packet loss rate;
- The ground absorbs and reflects radio waves, and the test effect is poor when close to the ground;
- Seawater has a strong ability to absorb radio waves, so the seaside test results are poor;
- If there are metal objects near the antenna, or if it is placed in a metal case, the signal attenuation will be very serious;
- The power register setting is wrong and the air rate is set too high (the higher the air rate, the closer the distance);
- The low voltage of the power supply at room temperature is lower than the recommended value. The lower the voltage, the smaller the transmit power;
- There is a poor match between the antenna and the module or there is a problem with the quality of the antenna itself.

11.2 Modules are vulnerable to damage

- Please check the power supply to ensure that it is within the recommended power supply voltage. If it exceeds the maximum value, it will cause permanent damage to the module;
- Please check the stability of the power supply. The voltage cannot fluctuate greatly and frequently;
- Please ensure anti-static operation during installation and use, as high-frequency devices are sensitive to static electricity;
- Please ensure that the humidity during installation and use should not be too high, as some components are humidity-sensitive devices;
- If there are no special needs, it is not recommended to use it at too high or too low temperature.

11.3 Bit error rate is too high

- If there is co-channel signal interference nearby, stay away from the interference source or modify the frequency or channel to avoid interference;
- Unsatisfactory power supply may also cause garbled code, so be sure to ensure the reliability of the power supply;
- Extension cords and feeders of poor quality or too long will also cause a high bit error rate.

XII. Welding Operation Guidance

12.1 Reflow temperature

Reflow soldering curve characteristics		Assembly with lead process	Lead free process assembly
Preheating/insulation	Minimum temperature (T _{min})	100°C	150°C
	Maximum temperature (T _{max})	150°C	200°C
	Time (T _{min} ~T _{min})	60-120 seconds	60-120 seconds
Heating slope (TL~Tp)		3 °C/s, maximum	3 °C/s, maximum
Liquid phase temperature (TL)		183°C	217°C
Holding time above TL		60-90 seconds	60~90seconds
Package peak temperature Tp		Users cannot exceed the temperature indicated on the "Moisture Sensitivity" label.	Users cannot exceed the temperature indicated on the "Moisture Sensitivity" label of the product.
Time (Tp) within 5 °C of the specified grading temperature (Tc), as shown in the following figure		20 seconds	30 seconds
Cooling slope (Tp~TL)		6°C/seconds, maximum	6°C/seconds, maximum
Time from room temperature to peak temperature		6 minutes, maximum	8 minutes, maximum
※The peak temperature (Tp) tolerance of the temperature curve is defined as the user's upper limit			

Revision History

Version	Revision date	Revision Description	Maintainer
1.0	2023-10-20	Initial version	Weng
1.1	2023-12-23	Content revision	Bin
1.2	2023-12-28	Content revision	Bin
1.3	2024-07-12	Content revision	Bin



About us

Technical support: support@cdebyte.com

Documents and RF Setting download link:<https://www.cdebyte.com>

Web: <https://www.cdebyte.com>

Address: Building B2, Mould Industrial Park, 199# Xi-Qu Ave, West High-tech Zone, Chengdu, 611731, Sichuan, China

Important Notice to OEM integrators

1. This module is limited to OEM installation ONLY.
2. This module is limited to installation in mobile or fixed applications, according to Part 2.1091(b).
3. The separate approval is required for all other operating configurations, including portable configurations with respect to Part 2.1093 and different antenna configurations
4. For FCC Part 15.31 (h) and (k): The host manufacturer is responsible for additional testing to verify compliance as a composite system. When testing the host device for compliance with Part 15 Subpart B, the host manufacturer is required to show compliance with Part 15 Subpart B while the transmitter module(s) are installed and operating. The modules should be transmitting and the evaluation should confirm that the module's intentional emissions are compliant (i.e. fundamental and out of band emissions). The host manufacturer must verify that there are no additional unintentional emissions other than what is permitted in Part 15 Subpart B or emissions are complaint with the transmitter(s) rule(s).
The Grantee will provide guidance to the host manufacturer for Part 15 B requirements if needed.

Important Note

notice that any deviation(s) from the defined parameters of the antenna trace, as described by the instructions, require that the host product manufacturer must notify to Chengdu Ebyte that they wish to change the antenna trace design. In this case, a Class II permissive change application is required to be filed by the USI, or the host manufacturer can take responsibility through the change in FCC ID (new application) procedure followed by a Class II permissive change application.

End Product Labeling

When the module is installed in the host device, the FCC ID label must be visible through a window on the final device or it must be visible when an access panel, door or cover is easily re-moved. If not, a second label must be placed on the outside of the final device that contains the following text:

"Contains FCC ID: 2A8C3-E52900NW22S"

The FCC ID can be used only when all FCC compliance requirements are met.

Antenna Installation

- (1) The antenna must be installed such that 20 cm is maintained between the antenna and users,
- (2) The transmitter module may not be co-located with any other transmitter or antenna.
- (3) Only antennas of the same type and with equal or less gains as shown below may be used with this module. Other types of antennas and/or higher gain antennas may require additional authorization for operation.

Antenna type	Peak Gain (dBi)
Monopole Antenna	3.0dBi

In the event that these conditions cannot be met (for example certain laptop configurations or co-location with

another transmitter), then the FCC authorization is no longer considered valid and the FCC ID cannot be used on the final product. In these circumstances, the OEM integrator will be responsible for re-evaluating the end product (including the transmitter) and obtaining a separate FCC authorization.

Manual Information to the End User

The OEM integrator has to be aware not to provide information to the end user regarding how to install or remove this RF module in the user's manual of the end product which integrates this module. The end user manual shall include all required regulatory information/warning as show in this manual.

Federal Communication Commission Interference Statement

This device complies with Part 15 of the FCC Rules. Operation is subject to the following two conditions: (1) This device may not cause harmful interference, and (2) this device must accept any interference received, including interference that may cause undesired operation.

This equipment has been tested and found to comply with the limits for a Class B digital device, pursuant to Part 15 of the FCC Rules. These limits are designed to provide reasonable protection against harmful interference in a residential installation. This equipment generates, uses and can radiate radio frequency energy and, if not installed and used in accordance with the instructions, may cause harmful interference to radio communications. However, there is no guarantee that interference will not occur in a particular installation. If this equipment does cause harmful interference to radio or television reception, which can be determined by turning the equipment off and on, the user is encouraged to try to correct the interference by one of the following measures:

- Reorient or relocate the receiving antenna.
- Increase the separation between the equipment and receiver.
- Connect the equipment into an outlet on a circuit different from that to which the receiver is connected.
- Consult the dealer or an experienced radio/TV technician for help.

Any changes or modifications not expressly approved by the party responsible for compliance could void the user's authority to operate this equipment. This transmitter must not be co-located or operating in conjunction with any other antenna or transmitter.

Radiation Exposure Statement

This equipment complies with FCC radiation exposure limits set forth for an uncontrolled environment. This equipment should be installed and operated with minimum distance 20 cm between the radiator & your body.

List of applicable FCC rules

This module has been tested and found to comply with part 15.247 requirements for Modular Approval.

The modular transmitter is only FCC authorized for the specific rule parts (i.e., FCC transmitter rules) listed on the grant, and that the host product manufacturer is responsible for compliance to any other FCC rules that apply to the host not covered by the modular transmitter grant of certification. If the grantee markets their product as being Part 15 Subpart B compliant (when it also contains unintentional-radiator digital circuit), then the grantee shall provide a notice stating that the final host product still requires Part 15 Subpart B compliance testing with the modular transmitter installed.

This device is intended only for OEM integrators under the following

conditions: (For module device use)

- 1) The antenna must be installed such that 20 cm is maintained between the antenna and users, and
- 2) The transmitter module may not be co-located with any other transmitter or antenna.

As long as 2 conditions above are met, further transmitter test will not be required. However, the OEM integrator is still responsible for testing their end-product for any additional compliance requirements required with this module installed.