

Antenna specification

Doc No.	IS-QR-PD-010
Rev.	V1.0
Page	1/8

Antenna specification

Applicant	Shanghai Huace Navigation Technology Ltd.
Address	577 Songying Road, Qingpu District, 201706 Shanghai, China

Antenna model: MARB AT V1.0

APPLications

※Bluetooth Home RF

※ISM band 2.4GHz applications

1. Dimensions

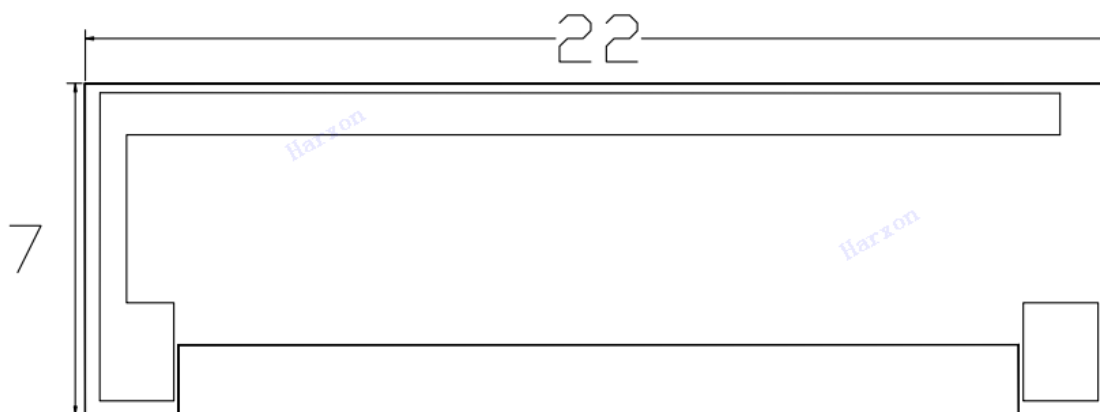

Size: length: 22mm width: 7mm

2. Specifications

number	Item	Specifications
1	Working Central Frequency	2441 MHz
2	Band Width	(2402-2480)MHz
3	Gain	0dBi
4	VSWR	Resonance point ≤ 2.0
5	Antenna type	PCB antenna
6	Azimuth Beam width	Omni - directional
7	Impedance	50ohm
8	Modulation mode	GFSK

3. simulation parameter

① VSWR

Mkr1: 2402MHz 4.3 Mkr2: 2441MHz 1.7 Mkr3: 2480 MHz 3.2

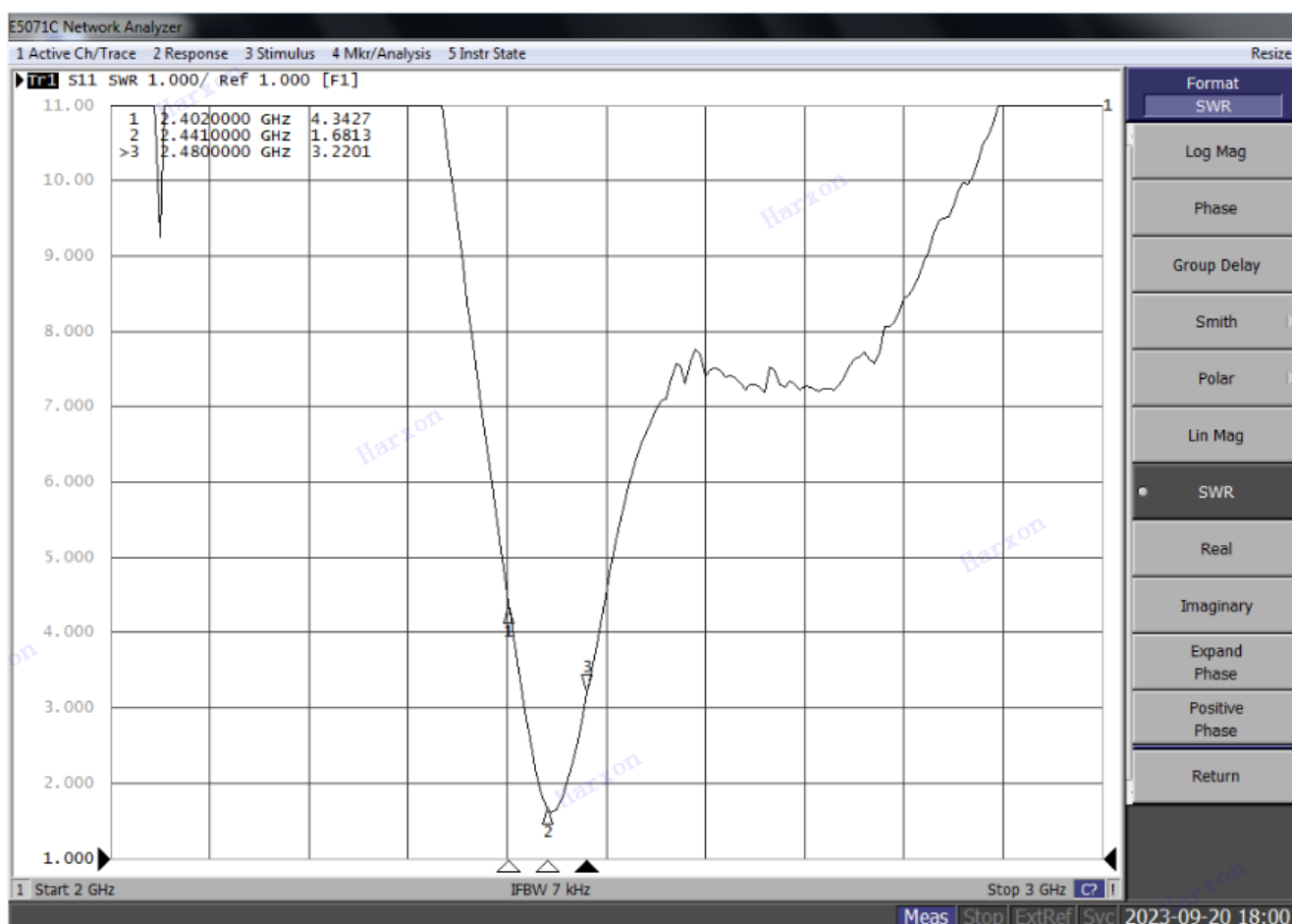

②Smith Chart

Mkr1: 2402MHz 16 Mkr2: 2441MHz 32 Mkr3: 2480MHz 160

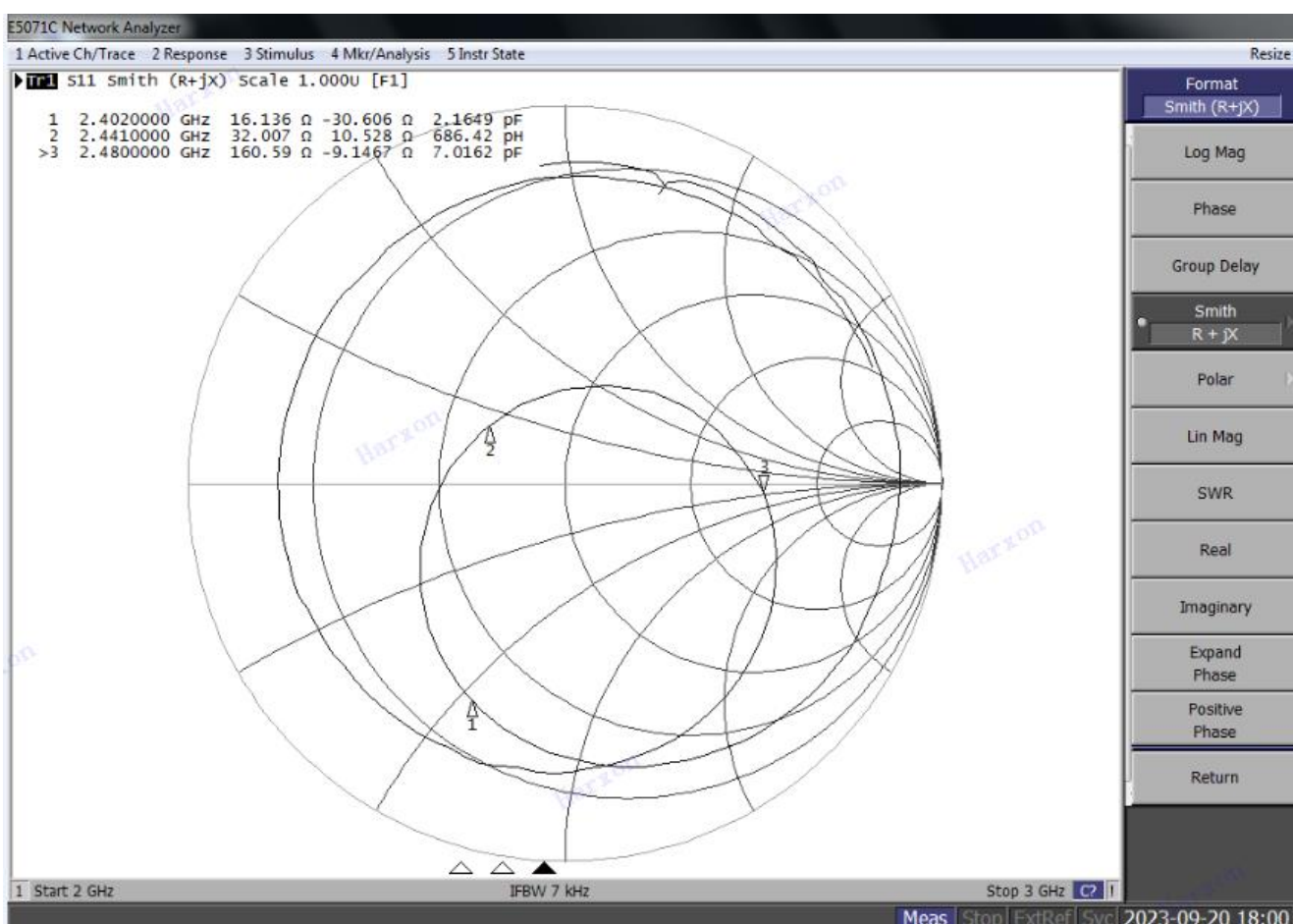

③Return Loss

Mkr1: 2402MHz -4 Mkr2: 2441MHz -11 Mkr3: 2480 MHz -5.6

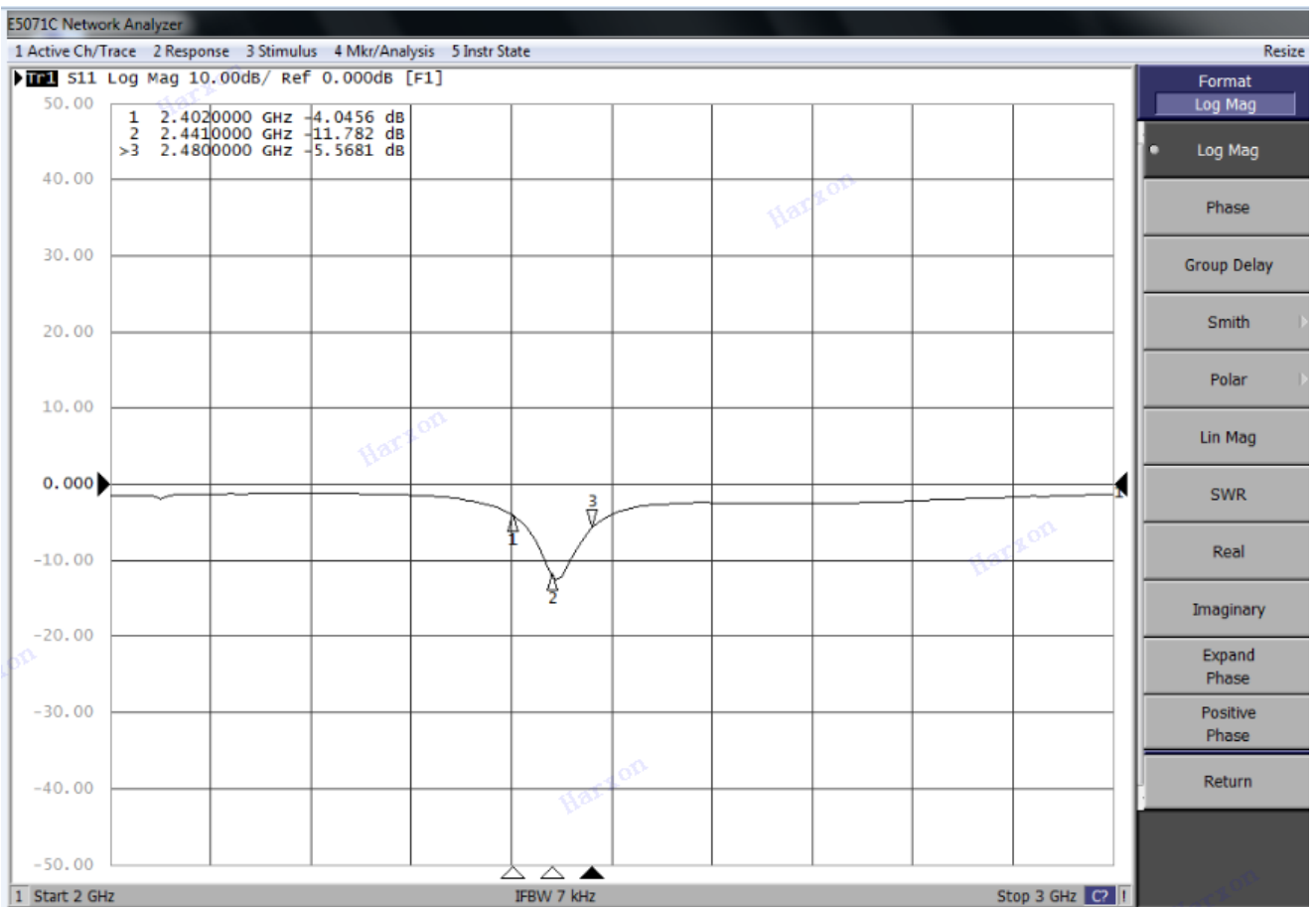

④Smith Chart

Mkr1: 2402MHz -4 Mkr2: 2441MHz -11 Mkr3: 2480 MHz -5.6

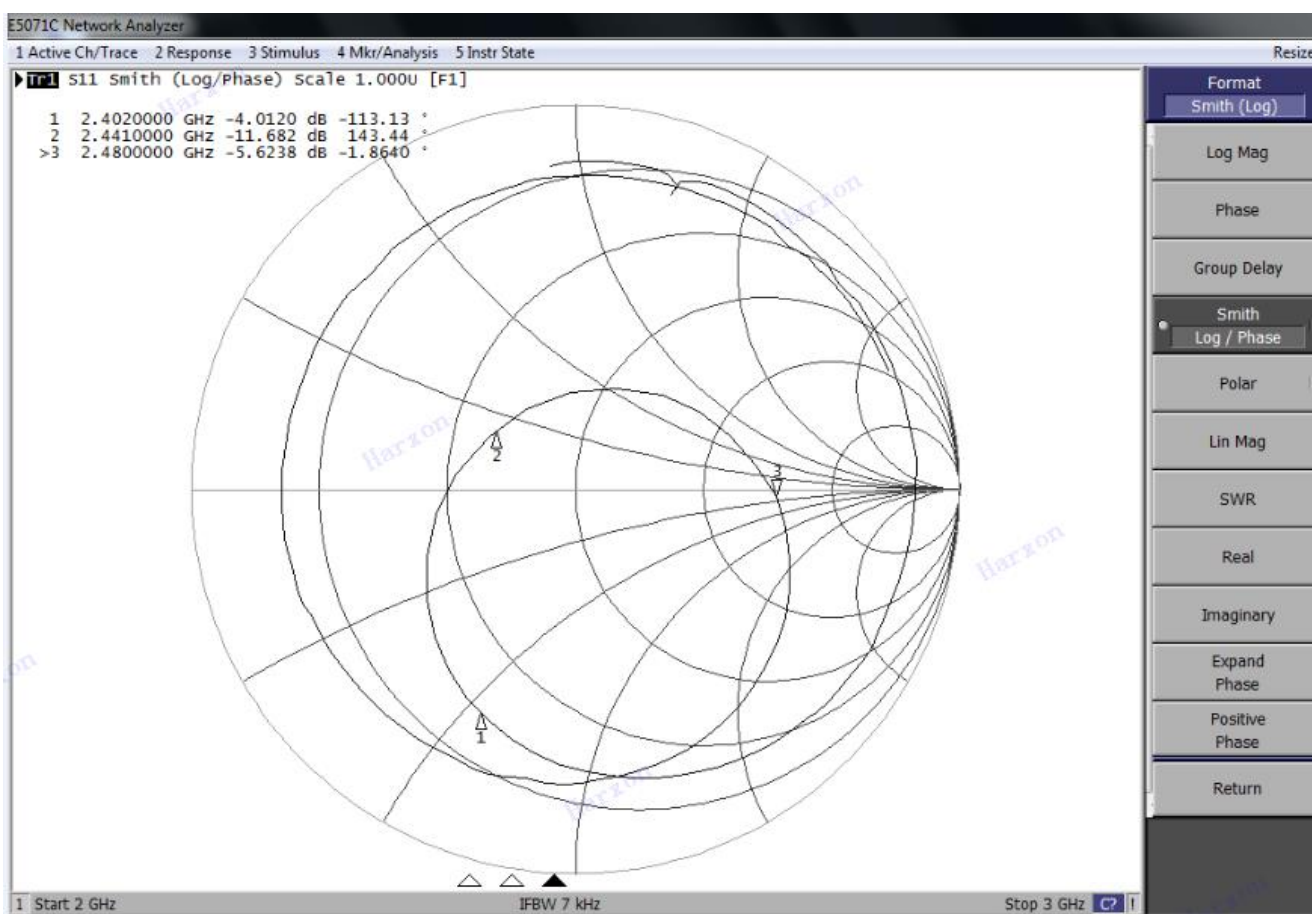

⑤Phase

7Mkr1: 2402MHz -113 Mkr2: 2441MHz 143 Mkr3: 2480MHz -1

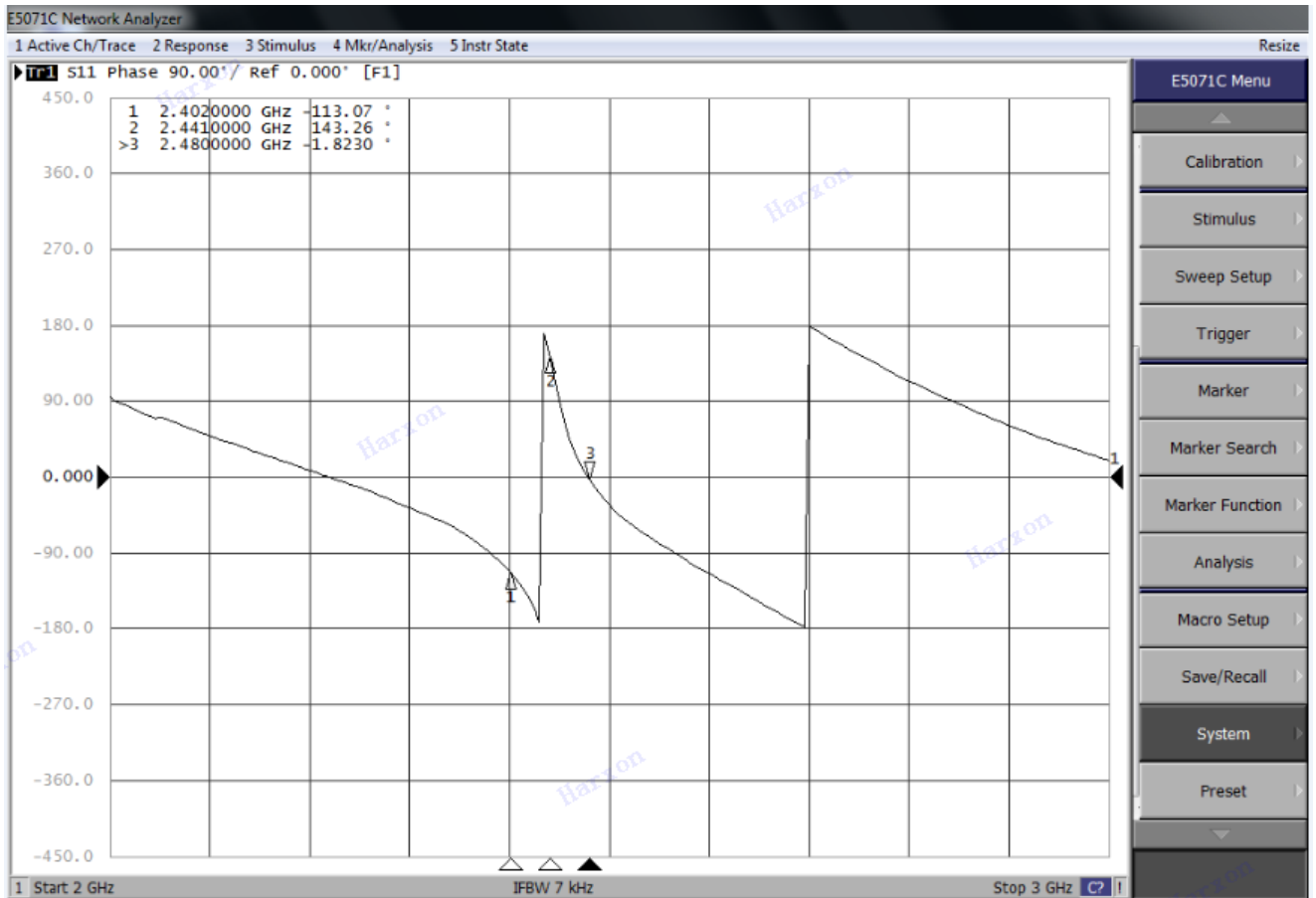

4. Radiation Patterns

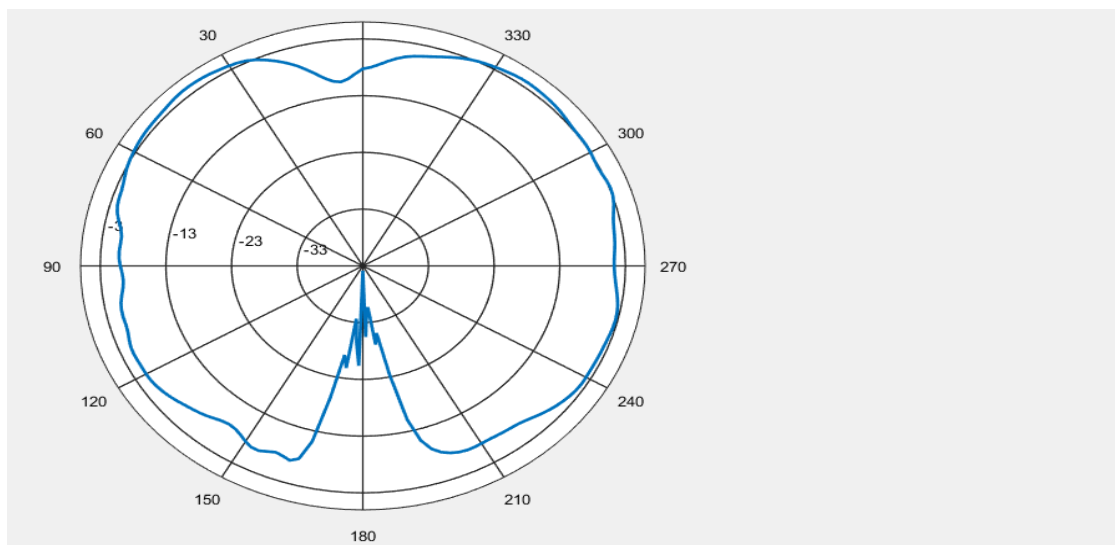

2441MHz

- 3DRadiation pattern

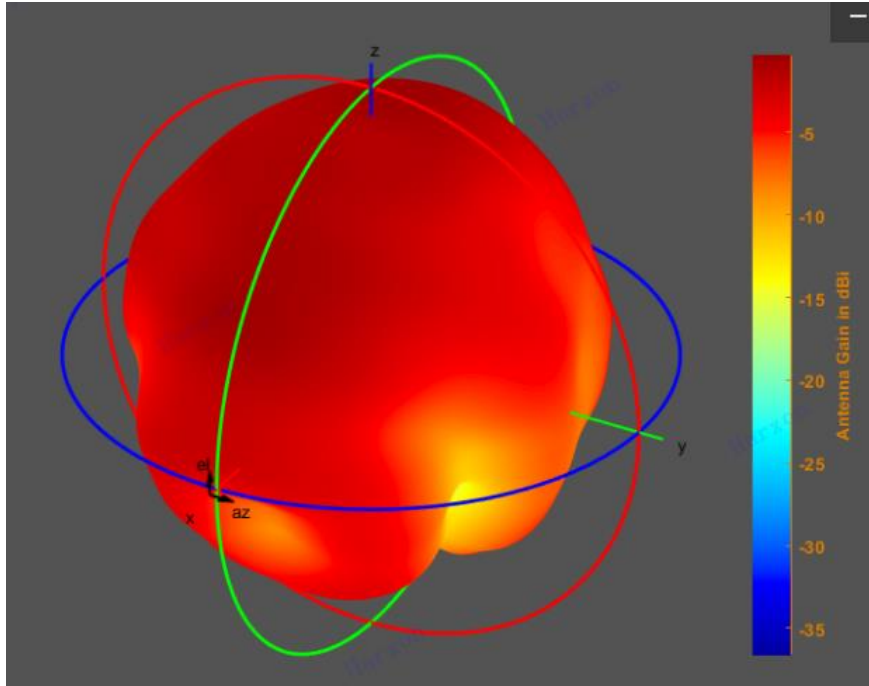

2441MHz