

承認書

SPECIFICATION FOR APPROVAL

客戶

CUSTOMER:

客戶料號:

CUST P/N:

天夏料號:

FINE P/N:

產品型號

DESC:

TX43.5*5.3*0.8-10TS-0.08*48P-6.5UH-25MM

日期

DATE:

2024/05/27

版本:

Version:

A.0

擬制 PREPARED BY	審核 CHECKED BY	批准 APPROVED BY	客戶承認 CUSTOMER APPROVE
陈诚佳	张燕	罗勇军	

深圳市天夏科技有限公司

Shenzhen Tianxia Technology Co., LTD

地址: 深圳市宝安区33区C33科创园523-525

Address: 523-525, C33 Science and Technology Park, Zone 33, Baoan District, Shenzhen

TEL: 18718699959

E-mail: 2321113770@qq.com

SPECIFICATION

产品型号 DESC	TX43.5*5.3*0.8-10TS-0.08* 48P---6.5UH-25MM	版本 Rev: A.0	客户 CUST: 客户料号 CUST P/N:	微电能
--------------	---	----------------	----------------------------	-----

一、尺寸 DIMENSION:(mm)

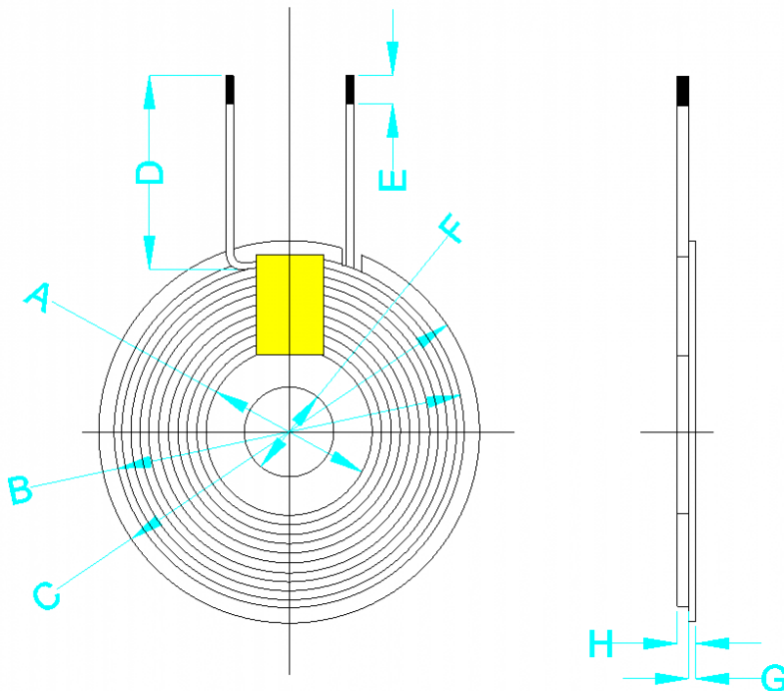

A	20.5±0.5
B	39±1
C	43.5±0.5
D	25±2
E	3±1
F	5.3±0.2
G	0.8±0.2
H	2.5Max

- 注:
1. 线圈为顺时针方向
 2. 线圈背面贴双面背胶
Attach double-sided backing tape to the back of the coil
 3. 出线处套23MM热缩管
Cover the outlet with a 23MM heat shrink pipe

二、原理图 SCHEMATIC DIAGRAM



三、绕线参数 Winding Specification:

序号 NO.	端子 TERMINAL		线径 WIRE	圈数 Turns	绕线方向 Winding Direction
1	S	F	0.08*48P	10Ts	CCW

四、电气特性 ELECTRICAL CHARACTERISTICS:

温度 TEMPERATURE:25±10°C, 湿度 RELATIVE HUMIDITY:65±20%

序号 NO.	项目 ITEM	端子 TERMINAL	标准 SPECIFICATION	测试条件 TEST FREQUENCY	测试仪器 TEST EQUIPMENTS
1	IND.	S-F	6.0uH ± 10% 单独线圈	100KHz/1.0V	LCR METER 106X
2	IND.	S-F	9.5uH ± 10% 带磁片	100KHz/1.0V	LCR METER 106X
3	DCR	S-F	600m Max	100KHz/1.0V	LCR METER 106X

拟制/日期 PREPARED BY/DATE 陈诚佳 2024/05/27	审核/日期 CHECKED BY/DATE 张燕 2024/05/27
--	--