

# TEST REPORT

## CERTIFICATE OF CONFORMITY

**Standard:** 47 CFR FCC Part 15, Subpart B, Class B  
ANSI C63.4: 2014

**Report No.:** FDCGWN-WTW-P23080612

**Product:** USB UHF RFID Reader

**Brand:** ACURA Technologies, part of HID

**Model No.:** AC-01 V2 OEM

**FCC ID:** 2A7XUAC01V2OEM

**Received Date:** 2023/8/25

**Test Date:** 2023/9/2

**Issued Date:** 2023/9/13

**Applicant:** Acura Technologies

**Address:** Avenida Antártico, 381, 14th andar - CEP: 09726-150 - São Bernardo do Campo – SP

**Issued By:** Bureau Veritas Consumer Products Services (H.K.) Ltd., Taoyuan Branch  
Lin Kou Laboratories

**Lab Address:** No. 47-2, 14th Ling, Chia Pau Vil., Lin Kou Dist., New Taipei City, Taiwan

**Test Location:** No. 19, Hwa Ya 2nd Rd., Wen Hwa Vil., Kewi Shan Dist., Taoyuan City 33383, Taiwan

### FCC Registration /

**Designation Number:** 328930 / TW1050

Approved by: \_\_\_\_\_

*Leo Hsu*

, Date: \_\_\_\_\_

2023/9/13

Leo Hsu / Project Engineer

This test report consists of 20 pages in total. It may be duplicated completely for legal use with the approval of the applicant. It should not be reproduced except in full, without the written approval of our laboratory. The test results in the report only apply to the tested sample. The test results in this report are traceable to the national or international standards.



Prepared by : Gina Liu / Specialist

This report is governed by, and incorporates by reference, the Conditions of Testing as posted at the date of issuance of this report at <http://www.bureauveritas.com/home/about-us/our-business/cps/about-us/terms-conditions/>, and is intended for your exclusive use. Any copying or replication of this report to or for any other person or entity, or use of our name or trademark, is permitted only with our prior written permission. This report sets forth our findings solely with respect to the test samples identified herein. The results set forth in this report are not indicative or representative of the quality or characteristics of the lot from which a test sample was taken or any similar or identical product unless specifically and expressly noted. Our report includes all of the tests requested by you and the results thereof based upon the information that you provided to us. Measurement uncertainty is only provided upon request for accredited tests. Statements of conformity are based on simple acceptance criteria without taking measurement uncertainty into account, unless otherwise requested in writing. You have 60 days from date of issuance of this report to notify us of any material error or omission caused by our negligence or if you require measurement uncertainty; provided, however, that such notice shall be in writing and shall specifically address the issue you wish to raise. A failure to raise such issue within the prescribed time shall constitute your unqualified acceptance of the completeness of this report, the tests conducted and the correctness of the report contents.

## Table of Contents

<b>Release Control Record .....</b>	<b>3</b>
<b>1 Certificate.....</b>	<b>4</b>
<b>2 Summary of Test Results .....</b>	<b>5</b>
2.1 Measurement Uncertainty .....	5
2.2 Supplementary Information .....	5
<b>3 General Information .....</b>	<b>6</b>
3.1 Description of EUT .....	6
3.2 Primary Clock Frequencies of Internal Source.....	6
3.3 Features of EUT .....	6
3.4 Operating Modes of EUT and Determination of Worst Case Operating Mode .....	6
3.5 Test Program Used and Operation Descriptions .....	7
3.6 Connection Diagram of EUT and Peripheral Devices .....	7
3.7 Configuration of Peripheral Devices and Cable Connections .....	7
<b>4 Test Instruments .....</b>	<b>8</b>
4.1 Conducted Emissions from Power Ports .....	8
4.2 Radiated Emissions up to 1 GHz .....	8
4.3 Radiated Emissions above 1 GHz.....	9
<b>5 Limits of Test Items.....</b>	<b>10</b>
5.1 Conducted Emissions from Power Ports .....	10
5.2 Radiated Emissions up to 1 GHz .....	10
5.3 Radiated Emissions above 1 GHz.....	10
<b>6 Test Arrangements.....</b>	<b>11</b>
6.1 Conducted Emissions from Power Ports .....	11
6.2 Radiated Emissions up to 1 GHz .....	12
6.3 Radiated Emissions above 1 GHz.....	13
<b>7 Test Results of Test Item .....</b>	<b>14</b>
7.1 Conducted Emissions from Power Ports .....	14
7.2 Radiated Emissions up to 1 GHz .....	16
7.3 Radiated Emissions above 1 GHz.....	18
<b>8 Information of the Testing Laboratories .....</b>	<b>20</b>



## Release Control Record

Issue No.	Description	Date Issued
FDCGWN-WTW-P23080612	Original release.	2023/9/13

## 1 Certificate

**Product:** USB UHF RFID Reader

**Brand:** ACURA Technologies, part of HID

**Test Model:** AC-01 V2 OEM

**FCC ID:** 2A7XUAC01V2OEM

**Sample Status:** Engineering sample

**Applicant:** Acura Technologies

**Test Date:** 2023/9/2

**Standard:** 47 CFR FCC Part 15, Subpart B, Class B  
ANSI C63.4: 2014

The above equipment has been tested by **Bureau Veritas Consumer Products Services (H.K.) Ltd., Taoyuan Branch**, and found compliance with the requirement of the above standards. The test record, data evaluation & Equipment Under Test (EUT) configurations represented herein are true and accurate accounts of the measurements of the sample's EMC characteristics under the conditions specified in this report.

## 2 Summary of Test Results

The test items that the EUT need to perform in accordance with its interfaces, evaluated functions, are as follows:

Standard / Clause	Test Item	Result	Remark
FCC Part 15.107	Conducted Emissions from Power Ports	Pass	Minimum passing Class B margin is -15.39 dB at 0.57400 MHz
FCC Part 15.109	Radiated Emissions up to 1 GHz	Pass	Minimum passing Class B margin is -6.16 dB at 48.07 MHz
FCC Part 15.109	Radiated Emissions above 1 GHz	Pass	Minimum passing Class B margin is -19.39 dB at 4599.83 MHz

Note: Determining compliance based on the results of the compliance measurement, not taking into account measurement instrumentation uncertainty.

### 2.1 Measurement Uncertainty

Where relevant, the following measurement uncertainty levels have been estimated for tests performed on the EUT as specified in CISPR 16-4-2:

Measurement	Specification	Expanded Uncertainty (k=2) (±)	Maximum allowable uncertainty (±)
Conducted Emissions from Power Ports	9 kHz ~ 30 MHz	2.99 dB	3.4 dB ( $U_{\text{CISPR}}$ )
Radiated Emissions up to 1 GHz	30 MHz ~ 1 GHz	4.72 dB	6.3 dB ( $U_{\text{CISPR}}$ )
Radiated Emissions above 1 GHz	1 GHz ~ 6 GHz	4.97 dB	5.2 dB ( $U_{\text{CISPR}}$ )
	6 GHz ~ 18 GHz	4.79 dB	5.5 dB ( $U_{\text{CISPR}}$ )

The other instruments specified are routine verified to remain within the calibrated levels, no measurement uncertainty is required to be calculated.

### 2.2 Supplementary Information

There is not any deviation from the test standards for the test method, and no modifications required for compliance.

### 3 General Information

#### 3.1 Description of EUT

Product	USB UHF RFID Reader
Brand	ACURA Technologies, part of HID
FCC ID	2A7XUAC01V2OEM
RF Module FCC ID	QV5MERCURY6EN
Test Model	AC-01 V2 OEM
Sample Status	Engineering sample
Operating Software	N/A
Power Supply Rating	5 Vdc (USB)
Accessory Device	N/A
Data Cable Supplied	N/A

#### 3.2 Primary Clock Frequencies of Internal Source

The highest frequency generated or used within the EUT or on which the EUT operates or tunes is 928MHz, provided by Acura Technologies, for detailed internal source, please refer to the manufacturer's specifications.

#### 3.3 Features of EUT

The tests reported herein were performed according to the method specified by Acura Technologies, for detailed feature description, please refer to the manufacturer's specifications or user's manual.

Please refer to appendix of the report if the applicant has provided additional descriptions of the EUT.

#### 3.4 Operating Modes of EUT and Determination of Worst Case Operating Mode

The EUT has been pre-tested under following test modes.

Test Condition	
Mode	Radiated Emissions up to 1 GHz
1	EUT Wall mount + USB Interface device + RFID Looping test.
<b>2</b>	<b>EUT Laying-flat + USB Interface device + RFID Looping test.</b>
Note: The worst case is that mode 2 is shown in bold.	

Test modes are presented in the report as below.

Test Condition	
Mode	Conducted Emissions from Power Ports
A	EUT Laying-flat + USB Interface device + RFID Looping test.
Mode	Radiated Emissions up to 1 GHz
A	EUT Laying-flat + USB Interface device + RFID Looping test.
Mode	Radiated Emissions above 1 GHz
A	EUT Laying-flat + USB Interface device + RFID Looping test.

### 3.5 Test Program Used and Operation Descriptions

- a. The laptop supplies power to EUT through USB.
- b. EUT does looping test through RFID function.

### 3.6 Connection Diagram of EUT and Peripheral Devices

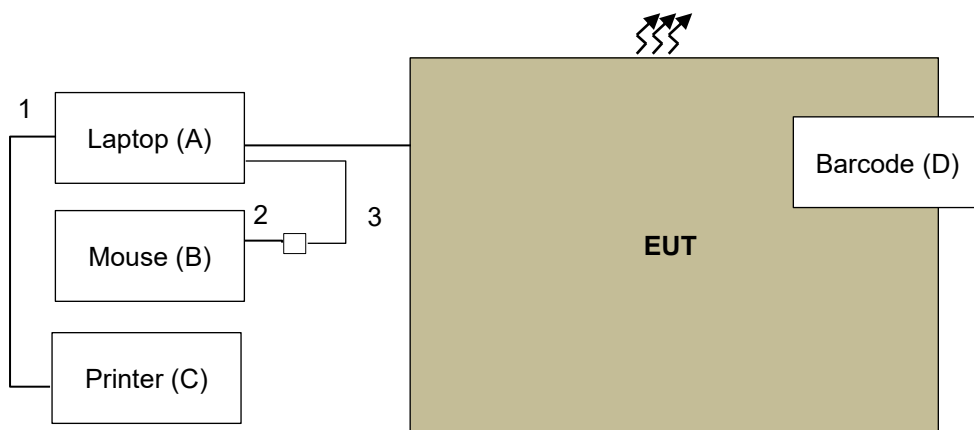

### 3.7 Configuration of Peripheral Devices and Cable Connections

ID	Product	Brand	Model No.	Serial No.	FCC ID	Remarks
A	Laptop	DELL	Latitude 5420	C6F33F3	N/A	Provided by Lab
B	Mouse	DELL	MS116P	CN-0145WW- PRC00-32R-07TQ	N/A	Provided by Lab
C	Printer	EPSON	T22	MEEZ070388	N/A	Provided by Lab
D	Barcode	N/A	N/A	N/A	N/A	Supplied by applicant

ID	Cable Descriptions	Qty.	Length (m)	Shielding (Yes/No)	Cores (Qty.)	Remarks
1	USB Cable	1	1.8	Yes	0	Provided by Lab
2	USB Cable	1	1.8	Yes	0	Provided by Lab
3	USB-C to A Cable	1	0.15	Yes	0	Provided by Lab

## 4 Test Instruments

The calibration interval of the all test instruments are 12 months and the calibrations are traceable to NML/ROC and NIST/USA.

### 4.1 Conducted Emissions from Power Ports

Description Manufacturer	Model No.	Serial No.	Calibrated Date	Calibrated Until
EMI Test Receiver R&S	ESCI	100613	2022/12/5	2023/12/4
LISN R&S	ENV216	101826	2023/3/23	2024/3/22
	ESH3-Z5	100311	2022/9/12	2023/9/11
RF Coaxial Cable Woken	5D-FB	Cable-cond1-01	2023/1/7	2024/1/6
Software BVADT	BVADT_Cond_ V7.3.7.4	N/A	N/A	N/A

Notes:

1. The test was performed in HY - Conduction 1.
2. The VCCI Site Registration No. is C-12040.
3. Tested Date: 2023/9/2

### 4.2 Radiated Emissions up to 1 GHz

Description Manufacturer	Model No.	Serial No.	Calibrated Date	Calibrated Until
Antenna Tower (H)	MFA-440	970705	N/A	N/A
Antenna Tower (V)	MFA-440	9707	N/A	N/A
Bi_Log Antenna Schwarzbeck	VULB 9168	9168-148	2022/12/20	2023/12/19
		9168-156	2022/12/20	2023/12/19
Controller (H)	MF7802	08093	N/A	N/A
Controller (V)	MF7802	074	N/A	N/A
EMI Test Receiver R&S	ESR7	101240	2022/11/7	2023/11/6
		101264	2023/4/10	2024/4/9
Fixed Attenuator Mini-Circuits	UNAT-5+	PAD-CH(H)-01	2022/9/3	2023/9/2
		PAD-CH(V)-01	2022/9/3	2023/9/2
Preamplifier Sonoma	310N	352923	2023/5/7	2024/5/6
		352924	2023/5/7	2024/5/6
RF Coaxial Cable TIMES	LMR-600(11.8M)+LMR-400 (7M)	CABLE-CH1(HOR)-01	2022/9/3	2023/9/2
	LMR-600(18M)+LMR-400 (7M)	CABLE-CH1(VER)-01	2022/9/3	2023/9/2
Software	ADT_Radiated_V8.7.08	N/A	N/A	N/A
Turn Table	DS430	50303	N/A	N/A

Notes:

1. The test was performed in HY - 10M Chamber. The test site validated date: 2023/7/29 (NSA)
2. The VCCI Site Registration No. is R-11893.
3. Tested Date: 2023/9/2



### 4.3 Radiated Emissions above 1 GHz

Description Manufacturer	Model No.	Serial No.	Calibrated Date	Calibrated Until
Antenna Tower BVADT	AT100	AT93021702	N/A	N/A
Band Pass Filter Micro-Tronics	BRM17690-01	002	2022/9/3	2023/9/2
	BRM50716-01	G010	2022/9/3	2023/9/2
Boresight antenna tower fixture BV	BAF-02	3	N/A	N/A
Controller BVADT	SC100	SC93021702	N/A	N/A
Fixed Attenuator Mini-Circuits	BW-N4W5+	PAD-CH3-03	2023/7/8	2024/7/7
Horn Antenna Schwarzbeck	BBHA 9120D	209	2022/11/13	2023/11/12
Preamplifier Agilent	8449B	3008A02465	2023/2/15	2024/2/14
Preamplifier EMCI	EMC012645SE	980338	2023/5/7	2024/5/6
PXA Signal Analyzer Keysight	N9030B	MY60070562	2023/2/22	2024/2/21
RF Coaxial Cable HUBER+SUHNER&EMCI	SUCOFLEX 104&EMC104-SM-SM- 8000	Cable-CH3- 03(309224+170907)	2023/7/8	2024/7/7
Software BVADT	ADT_Radiated_V8.7.08	N/A	N/A	N/A
Turn Table BVADT	TT100	TT93021702	N/A	N/A

Notes:

1. The test was performed in HY - 966 Chamber 2. The test site validated date: 2023/4/29 (VSWR)
2. The VCCI Site Registration No. is G-20126.
3. Tested Date: 2023/9/2

## 5 Limits of Test Items

### 5.1 Conducted Emissions from Power Ports

Frequency (MHz)	Class A (dBuV)		Class B (dBuV)	
	Quasi-peak	Average	Quasi-peak	Average
0.15 - 0.5	79	66	66 - 56	56 - 46
0.50 - 5.0	73	60	56	46
5.0 - 30.0	73	60	60	50

Notes: 1. The lower limit shall apply at the transition frequencies.  
 2. The limit decreases linearly with the logarithm of the frequency in the range of 0.15 to 0.50 MHz.

### 5.2 Radiated Emissions up to 1 GHz

Emissions radiated outside of the specified bands, shall be according to the general radiated limits as following:

Radiated Emissions Limits at 10 meters (dB $\mu$ V/m)				
Frequencies (MHz)	FCC 15B, Class A	FCC 15B, Class B	CISPR 22, Class A	CISPR 22, Class B
30-88	39.1	29.5	40	30
88-216	43.5	33.1		
216-230	46.4	35.6		
230-960				
960-1000	49.5	43.5	47	37

Radiated Emissions Limits at 3 meters (dB $\mu$ V/m)				
Frequencies (MHz)	FCC 15B, Class A	FCC 15B, Class B	CISPR 22, Class A	CISPR 22, Class B
30-88	49.5	40.0	50.5	40.5
88-216	54.0	43.5		
216-230	56.9	46.0		
230-960				
960-1000	60.0	54.0	57.5	47.5

Notes: 1. The lower limit shall apply at the transition frequencies.

### 5.3 Radiated Emissions above 1 GHz

Frequency Range (For unintentional radiators)

Highest frequency generated or used in the device or on which the device operates or tunes (MHz)	Upper frequency of measurement range (MHz)
Below 1.705	30
1.705-108	1000
108-500	2000
500-1000	5000
Above 1000	5th harmonic of the highest frequency or 40GHz, whichever is lower

Radiated Emissions Limits at 3 meters (dB $\mu$ V/m)		
Frequency range	Class A	Class B
Above 1GHz	Avg: 60 Peak: 80	Avg: 54 Peak: 74

Notes: 1. These limit levels apply for a measurement distance of 3 m. If using a different measurement distance, the measured levels shall be extrapolated to the 3 m limit distance using a factor of 20 dB per decade of distance. The measurement distance shall place the measurement antenna in the far field of the ITE or digital apparatus under test.

## 6 Test Arrangements

### 6.1 Conducted Emissions from Power Ports

- For the table-top EUT is placed on a 0.8 meter insulation table; for the floor standing EUT shall be insulated (by insulation of 12 mm) from the horizontal reference ground plane. The EUT is placed 0.4 meters from the conducting wall of the shielded room with EUT being connected to the power mains through a line impedance stabilization network (LISN). Other support units are connected to the power mains through another LISN. They provide coupling impedance for the measuring instrument.
- Both lines of the power mains connected to the EUT were checked for maximum conducted interference.
- The test results of conducted emissions at mains ports are recorded of six worst margins for quasi-peak (mandatory) [and average (if necessary)] values against the limits at frequencies of interest unless the margin is 20 dB or greater.

Note: The resolution bandwidth and video bandwidth of test receiver is 9kHz for quasi-peak detection (QP) and average detection (AV) at frequency 0.15MHz-30MHz.

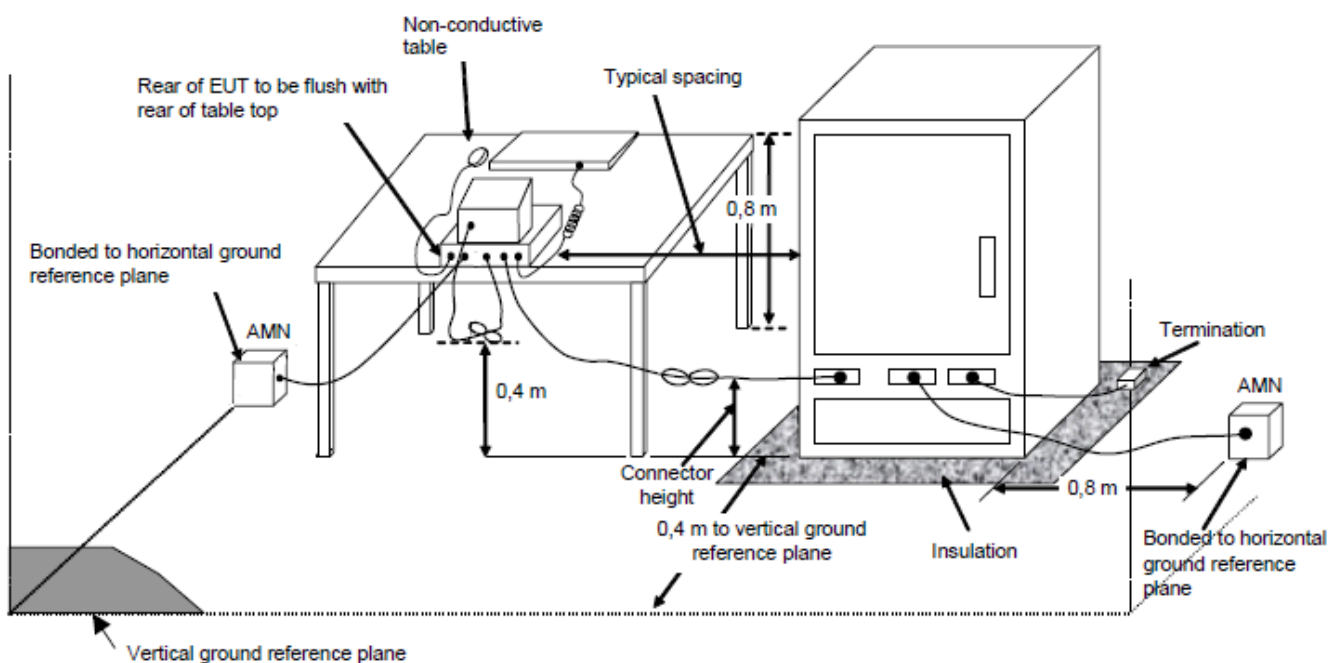

For the actual test configuration, please refer to the related Item – Photographs of the Test Configuration.

## 6.2 Radiated Emissions up to 1 GHz

- a. For the table-top EUT is placed on a 0.8 meter to the top of rotating table; for the floor standing EUT shall be insulated (by insulation of 12 mm) from the horizontal reference ground plane. The rotating table is rotated 360 degrees to determine the position of the highest radiation. If the equipment requires a dedicated ground connection, this shall be provided and bonded to the RGP.
- b. The EUT was set 10 meters away from the interference-receiving antenna, which was mounted on the top of a variable-height antenna tower.
- c. The antenna is a broadband antenna, and its height is varied from one meter to four meters above the ground to determine the maximum value of the field strength. Both horizontal and vertical polarizations of the antenna are set to make the measurement.
- d. For each suspected emission, the EUT was arranged to its worst case and then the antenna was tuned to heights from 1 meter to 4 meters and the rotatable table was turned from 0 degrees to 360 degrees to find the maximum reading.
- e. The test-receiver system was set to quasi-peak detect function and specified bandwidth with maximum hold mode when the test frequency is up to 1 GHz.

Note: The resolution bandwidth and video bandwidth of test receiver/spectrum analyzer is 120kHz for quasi-peak detection (QP) at frequency up to 1GHz.

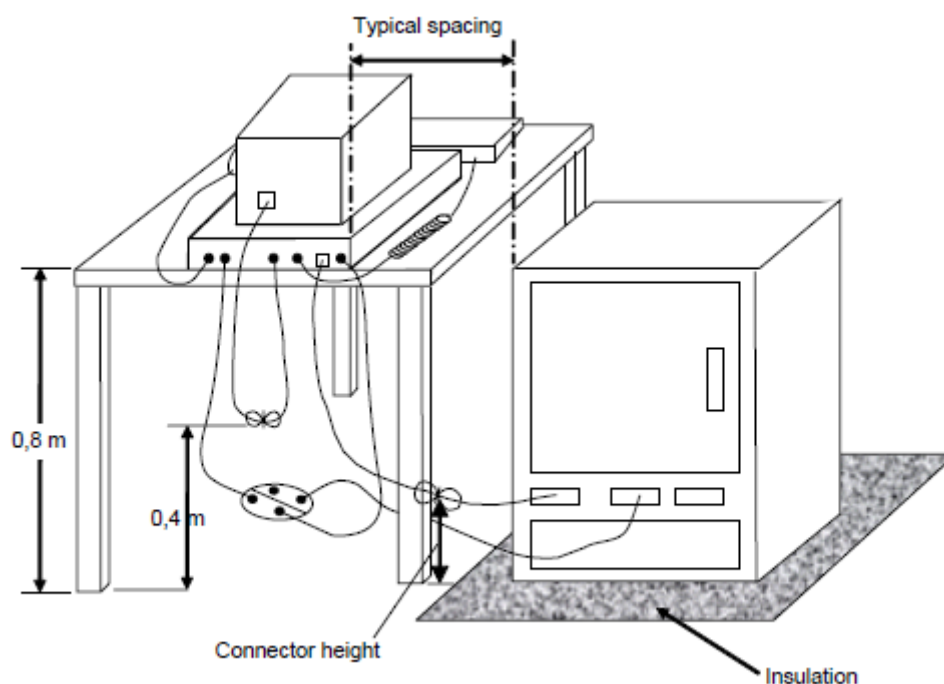

For the actual test configuration, please refer to the related Item – Photographs of the Test Configuration.

### 6.3 Radiated Emissions above 1 GHz

- For the table-top EUT is placed on a 0.8 meter to the top of rotating table; for the floor standing EUT shall be insulated (by insulation of 12 mm) from the horizontal reference ground plane. The rotating table is rotated 360 degrees to determine the position of the highest radiation. If the equipment requires a dedicated ground connection, this shall be provided and bonded to the RGP.
- The EUT was set  $d = 3$  meters away from the interference-receiving antenna, which was mounted on the top of a variable-height antenna tower.
- The height of antenna can be varied from one meter to four meters, the height of adjustment depends on the EUT height and the antenna 3dB beamwidth both, to detect the maximum value of the field strength. Both horizontal and vertical polarizations of the antenna are set to make the measurement.
- For each suspected emission, the EUT was arranged to its worst case and then the antenna was tuned to heights and the rotatable table was turned from 0 degrees to 360 degrees to find the maximum reading.
- The spectrum analyzer system was set to peak and average detects function and specified bandwidth with maximum hold mode when the test frequency is above 1 GHz.

Note: The resolution bandwidth of test receiver/spectrum analyzer is 1MHz and video bandwidth is 3MHz for Peak detection (PK) at frequency above 1GHz. The resolution bandwidth of test receiver/spectrum analyzer is 1 MHz for Average detection (AV) at frequency above 1GHz.

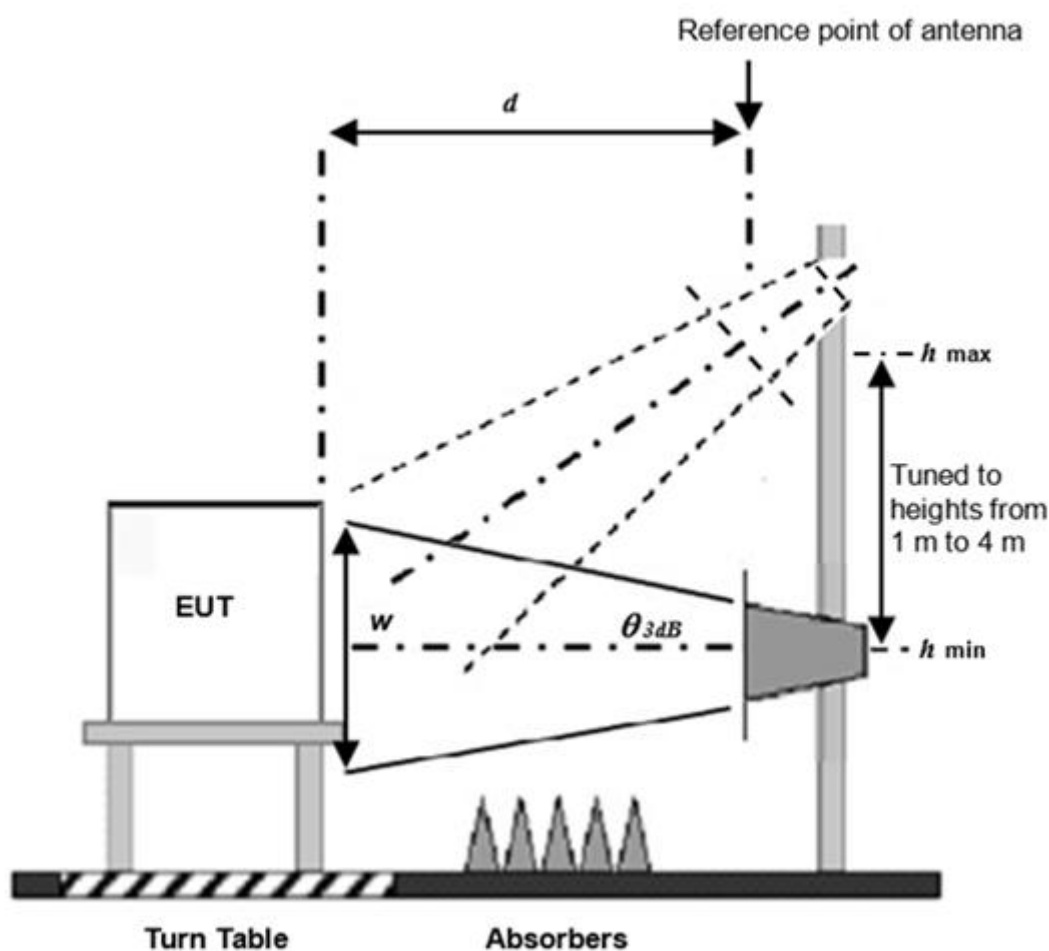

For the actual test configuration, please refer to the related item – Photographs of the Test Configuration.

## 7 Test Results of Test Item

### 7.1 Conducted Emissions from Power Ports

#### Mode A

Frequency Range	150 kHz ~ 30 MHz	Detector Function & Resolution Bandwidth	Quasi-Peak (QP) / Average (AV), 9kHz
Input Power	AC 120 V/60 Hz	Environmental Conditions	23°C, 63% RH
Tested by	Fox Chang		

Phase Of Power : Line (L)										
No	Frequency (MHz)	Correction Factor (dB)	Reading Value (dBuV)		Emission Level (dBuV)		Limit (dBuV)		Margin (dB)	
			Q.P.	AV.	Q.P.	AV.	Q.P.	AV.	Q.P.	AV.
1	0.15400	9.62	38.13	24.27	47.75	33.89	65.78	55.78	-18.03	-21.89
2	0.17384	9.63	33.59	19.02	43.22	28.65	64.77	54.77	-21.55	-26.12
3	0.29000	9.65	23.90	13.84	33.55	23.49	60.52	50.52	-26.97	-27.03
<b>4</b>	<b>0.57400</b>	<b>9.68</b>	<b>27.95</b>	<b>20.93</b>	<b>37.63</b>	<b>30.61</b>	<b>56.00</b>	<b>46.00</b>	<b>-18.37</b>	<b>-15.39</b>
5	3.39400	9.73	15.16	4.04	24.89	13.77	56.00	46.00	-31.11	-32.23
6	3.95400	9.74	17.58	5.58	27.32	15.32	56.00	46.00	-28.68	-30.68
7	13.38600	9.79	20.82	15.52	30.61	25.31	60.00	50.00	-29.39	-24.69

#### Remarks:

1. Q.P. and AV. are abbreviations of quasi-peak and average individually.
2. The emission levels of other frequencies were very low against the limit.
3. Margin value = Emission level – Limit value
4. Correction factor = Insertion loss + Cable loss
5. Emission Level = Correction Factor + Reading Value

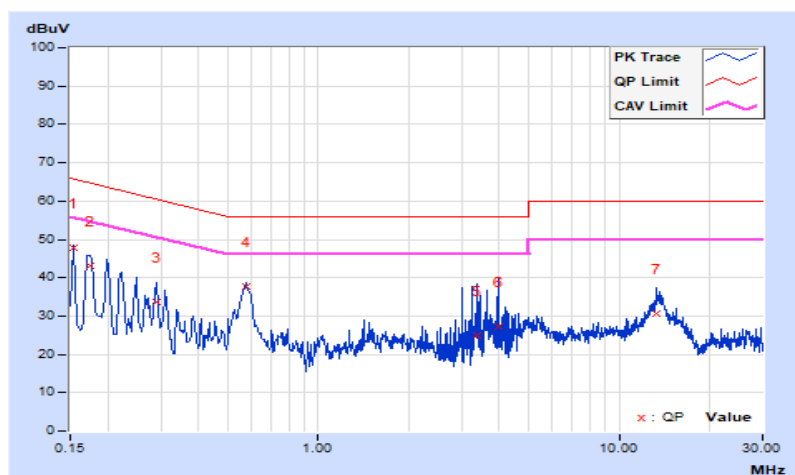

<b>Frequency Range</b>	150 kHz ~ 30 MHz	<b>Detector Function &amp; Resolution Bandwidth</b>	Quasi-Peak (QP) / Average (AV), 9kHz
<b>Input Power</b>	AC 120 V/60 Hz	<b>Environmental Conditions</b>	23°C, 63% RH
<b>Tested by</b>	Fox Chang		

Phase Of Power : Neutral (N)										
No	Frequency (MHz)	Correction Factor (dB)	Reading Value (dBuV)		Emission Level (dBuV)		Limit (dBuV)		Margin (dB)	
			Q.P.	AV.	Q.P.	AV.	Q.P.	AV.	Q.P.	AV.
1	0.15000	9.62	37.64	22.05	47.26	31.67	66.00	56.00	-18.74	-24.33
2	0.16535	9.63	35.59	20.22	45.22	29.85	65.19	55.19	-19.97	-25.34
3	0.26200	9.65	23.45	12.06	33.10	21.71	61.37	51.37	-28.27	-29.66
4	0.56600	9.68	27.74	19.39	37.42	29.07	56.00	46.00	-18.58	-16.93
5	1.72600	9.71	15.64	10.60	25.35	20.31	56.00	46.00	-30.65	-25.69
6	4.03800	9.75	18.47	8.36	28.22	18.11	56.00	46.00	-27.78	-27.89
7	13.66200	9.84	19.21	13.74	29.05	23.58	60.00	50.00	-30.95	-26.42

**Remarks:**

1. Q.P. and AV. are abbreviations of quasi-peak and average individually.
2. The emission levels of other frequencies were very low against the limit.
3. Margin value = Emission level – Limit value
4. Correction factor = Insertion loss + Cable loss
5. Emission Level = Correction Factor + Reading Value

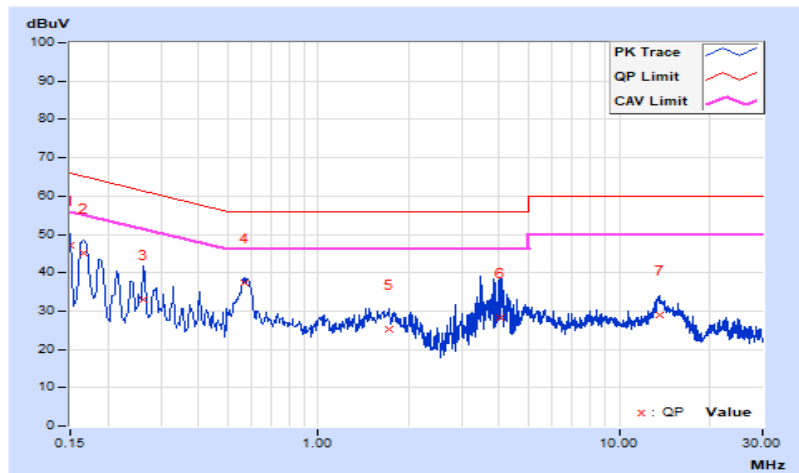

## 7.2 Radiated Emissions up to 1 GHz

### Mode A

Frequency Range	30 MHz ~ 1 GHz	Detector Function & Resolution Bandwidth	Quasi-Peak (QP), 120 kHz
Input Power	120 Vac, 60 Hz	Environmental Conditions	23°C, 63% RH
Tested By	Fox Chang		

Antenna Polarity & Test Distance : Horizontal at 10 m								
No	Frequency (MHz)	Emission Level (dBuV/m)	Limit (dBuV/m)	Margin (dB)	Antenna Height (m)	Table Angle (Degree)	Raw Value (dBuV)	Correction Factor (dB/m)
1	48.98	17.07 QP	30.00	-12.93	2.00 H	231	29.16	-12.09
2	120.05	15.56 QP	30.00	-14.44	2.00 H	333	31.05	-15.49
3	154.77	15.89 QP	30.00	-14.11	1.00 H	42	28.83	-12.94
4	186.11	17.59 QP	30.00	-12.41	3.50 H	210	32.39	-14.80
5	315.60	17.20 QP	37.00	-19.80	3.50 H	105	29.09	-11.89
6	484.38	22.00 QP	37.00	-15.00	3.00 H	52	29.71	-7.71

#### Remarks:

1. Emission Level(dBuV/m) = Raw Value(dBuV) + Correction Factor(dB/m)
2. Correction Factor(dB/m) = Antenna Factor (dB/m) + Cable Factor (dB)  
– Pre-Amplifier Factor (dB)
3. Margin value = Emission level – Limit value
4. The other emission levels were very low against the limit.

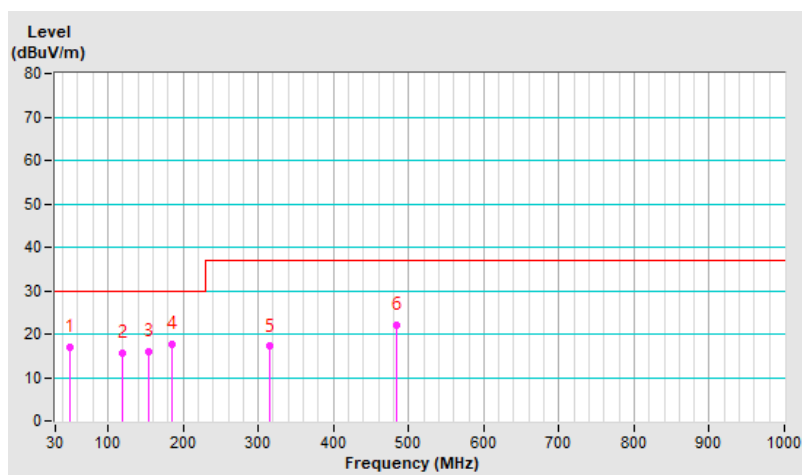



<b>Frequency Range</b>	30 MHz ~ 1 GHz	<b>Detector Function &amp; Resolution Bandwidth</b>	Quasi-Peak (QP), 120 kHz
<b>Input Power</b>	120 Vac, 60 Hz	<b>Environmental Conditions</b>	23°C, 63% RH
<b>Tested By</b>	Fox Chang		

Antenna Polarity & Test Distance : Vertical at 10 m								
No	Frequency (MHz)	Emission Level (dBuV/m)	Limit (dBuV/m)	Margin (dB)	Antenna Height (m)	Table Angle (Degree)	Raw Value (dBuV)	Correction Factor (dB/m)
1	48.07	23.84 QP	30.00	-6.16	1.50 V	268	35.94	-12.10
2	62.82	20.73 QP	30.00	-9.27	1.50 V	134	34.11	-13.38
3	102.07	22.48 QP	30.00	-7.52	4.00 V	119	39.69	-17.21
4	120.08	23.02 QP	30.00	-6.98	2.00 V	11	38.43	-15.41
5	191.89	18.84 QP	30.00	-11.16	1.50 V	302	34.16	-15.32
6	251.10	21.44 QP	37.00	-15.56	1.00 V	280	35.00	-13.56

**Remarks:**

1. Emission Level(dBuV/m) = Raw Value(dBuV) + Correction Factor(dB/m)
2. Correction Factor(dB/m) = Antenna Factor (dB/m) + Cable Factor (dB)  
– Pre-Amplifier Factor (dB)
3. Margin value = Emission level – Limit value
4. The other emission levels were very low against the limit.

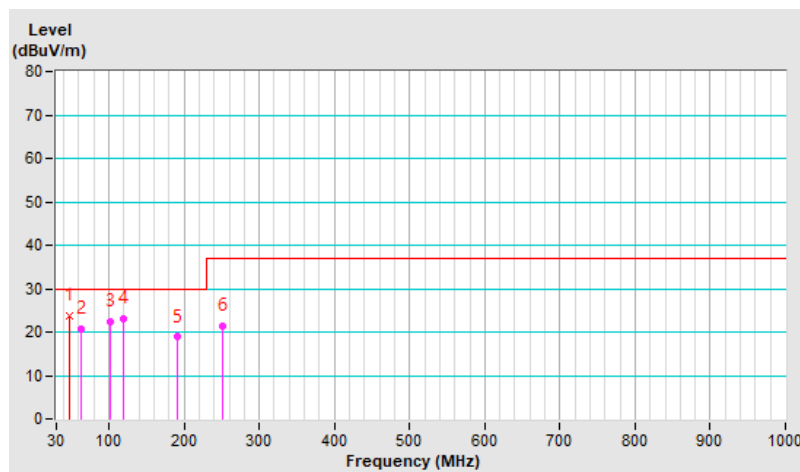

### 7.3 Radiated Emissions above 1 GHz

#### Mode A

Frequency Range	1 GHz ~ 18 GHz	Detector Function & Resolution Bandwidth	Peak (PK) / Average (AV), 1MHz
Input Power	120 Vac, 60 Hz	Environmental Conditions	23°C, 70% RH
Tested By	Nick Wu		

Antenna Polarity & Test Distance : Horizontal at 3 m								
No	Frequency (MHz)	Emission Level (dBuV/m)	Limit (dBuV/m)	Margin (dB)	Antenna Height (m)	Table Angle (Degree)	Raw Value (dBuV)	Correction Factor (dB/m)
1	1838.54	49.82 PK	74.00	-24.18	1.74 H	148	51.78	-1.96
2	1838.54	32.33 AV	54.00	-21.67	1.74 H	148	34.29	-1.96
3	2773.87	47.58 PK	74.00	-26.42	1.00 H	303	46.04	1.54
4	2773.87	31.02 AV	54.00	-22.98	1.00 H	303	29.48	1.54
5	4594.73	46.07 PK	74.00	-27.93	1.21 H	346	39.46	6.61
6	4594.73	33.91 AV	54.00	-20.09	1.21 H	346	27.30	6.61

#### Remarks:

1. Emission Level(dBuV/m) = Raw Value(dBuV) + Correction Factor(dB/m)
2. Correction Factor(dB/m) = Antenna Factor (dB/m) + Cable Factor (dB)  
– Pre-Amplifier Factor (dB)
3. Margin value = Emission level – Limit value
4. The other emission levels were very low against the limit.

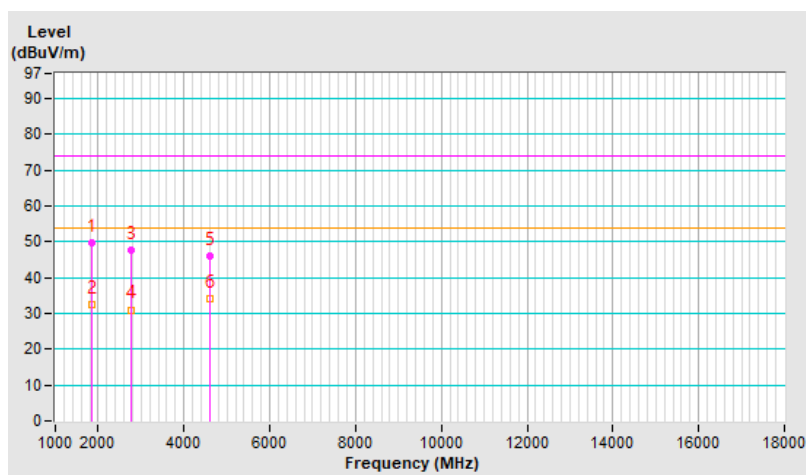

<b>Frequency Range</b>	1 GHz ~ 18 GHz	<b>Detector Function &amp; Resolution Bandwidth</b>	Peak (PK) / Average (AV), 1MHz
<b>Input Power</b>	120 Vac, 60 Hz	<b>Environmental Conditions</b>	23°C, 70% RH
<b>Tested By</b>	Nick Wu		

Antenna Polarity & Test Distance : Vertical at 3 m								
No	Frequency (MHz)	Emission Level (dBuV/m)	Limit (dBuV/m)	Margin (dB)	Antenna Height (m)	Table Angle (Degree)	Raw Value (dBuV)	Correction Factor (dB/m)
1	1743.90	41.34 PK	74.00	-32.66	1.20 V	66	43.68	-2.34
2	1743.90	27.65 AV	54.00	-26.35	1.20 V	66	29.99	-2.34
3	2754.01	48.57 PK	74.00	-25.43	1.91 V	146	47.01	1.56
4	2754.01	32.69 AV	54.00	-21.31	1.91 V	146	31.13	1.56
5	4599.83	47.84 PK	74.00	-26.16	1.90 V	199	41.19	6.65
<b>6</b>	<b>4599.83</b>	<b>34.61 AV</b>	<b>54.00</b>	<b>-19.39</b>	<b>1.90 V</b>	<b>199</b>	<b>27.96</b>	<b>6.65</b>

**Remarks:**

1. Emission Level(dBuV/m) = Raw Value(dBuV) + Correction Factor(dB/m)
2. Correction Factor(dB/m) = Antenna Factor (dB/m) + Cable Factor (dB) – Pre-Amplifier Factor (dB)
3. Margin value = Emission level – Limit value
4. The other emission levels were very low against the limit.

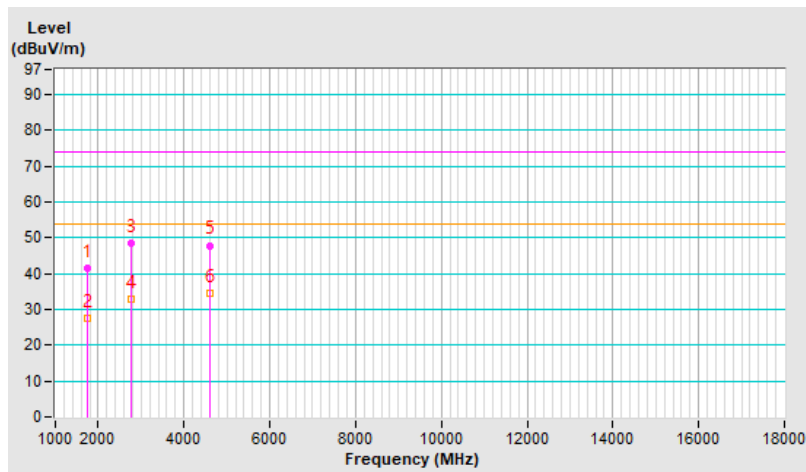

## 8 Information of the Testing Laboratories

We, Bureau Veritas Consumer Products Services (H.K.) Ltd., Taoyuan Branch, were founded in 1988 to provide our best service in EMC, Radio, Telecom and Safety consultation. Our laboratories are FCC recognized accredited test firms and accredited according to ISO/IEC 17025.

If you have any comments, please feel free to contact us at the following:

**Lin Kou EMC/RF Lab**

Tel: 886-2-26052180

Fax: 886-2-26051924

**Hsin Chu EMC/RF/Telecom Lab**

Tel: 886-3-6668565

Fax: 886-3-6668323

**Hwa Ya EMC/RF/Safety Lab**

Tel: 886-3-3183232

Fax: 886-3-3270892

**Email:** [service.adt@bureauveritas.com](mailto:service.adt@bureauveritas.com)

**Web Site:** <http://ee.bureauveritas.com.tw>

The address and road map of all our labs can be found in our web site also.

--- END ---