

Shenzhen Zhenduan Electronic Technology Co., Ltd

SPECIFICATION FOR APPROVAL

CUSTOMER

Product Name of Customer 303030-00020

product Name of Ours (Material) A11 D43*0.5MM
3MM Gummed paper L45MM

APPROVED

APPROVED 邓湘 **DRAWN** 赖伟 **DATE** 2022.3.23



REVISED RECORD

PEVISON NO	DATE	REVISE DESCRIPTION		Change person
REV:01				
REV:02				
ESCRINED		CHECKED	APPROVED	PACE
赖伟		邓湘	陈展良	

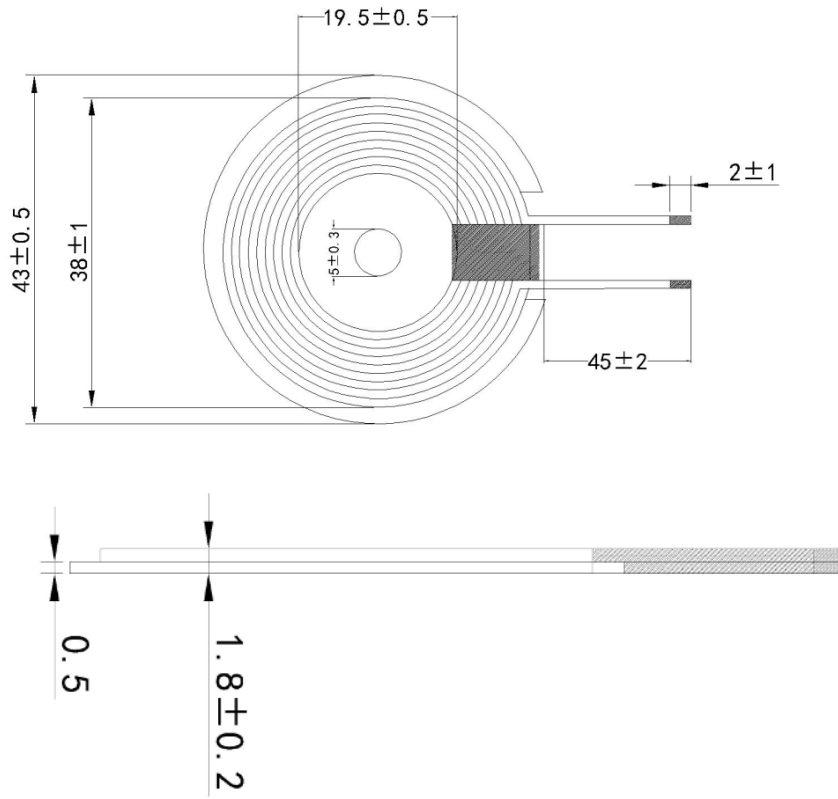

UNIT: mm

* Dimension without tolerance is approx.

3. Coils Specification

3-1. Connection (Bottom View)

“●” START

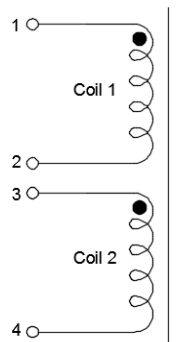

Note:	Spec. No.
-------	-----------

Specifcation	CUSTOMERP/N:	
	PARTNUMBER:	

5.WINDING DETAILS:

Wdy.NO.	Start	Finish	Turns	Wire Dia	Wdg.TyepeSprad/lose	Wdg.Direction	Turns/Layer
	S	F	10TS	0.08*48P	Single-layeer	Anticlockwise	1 /10TS

6.ELECTRICAL CHARACTERISTICS:

PARAMETERS	UNIN	LIMTI
Inductance $I_s@100KHz/1v$	uh	$6.5 \pm 5\%$
Q @100KHz/1v		38MIN
DCR @100KHz/1v	mΩ	90MAX

APPROVED BY	CHECKED BY	PREPARED BY	DATE	PAGE
		赖伟	2022.3.23	

MATERIAL LIST					CUSTOMER P/N:	
					PARTNUMBER:	
NO.	Material name	Description	Manufacturer	Material		
1	Silk-covered wire	0.08*48P				
2	Lead free tin	High temperatuye				
3	Alloy sheet	43*0.5				
4	High temperature adhesive tape	5mm				
5	Sponge	42*0.5mm				
6	3MGummed paper	43mm				
APPROVED BY		CHECKED BY	PREPARED BY	DATE		PAGE
			赖伟	2022.3.23		