

# H7161 英语说明书

版本：v1.0

尺寸：75×105 (mm)

材质：80G书页纸

工艺：单色印刷

折叠方式：骑马钉

页数：24页



# GoveeLife

Model: H7161



## User Manual

Smart Aroma Diffuser

# Contents

Safety Instructions	01
Introduction	03
Operation	07
Govee Home App	10
Cleaning Instructions	11
Troubleshooting	14
Appendix	18
Compliance Information	19

# GoveeLife Smart Aroma Diffuser User Manual

## READ AND SAVE THESE INSTRUCTIONS

### Safety Instructions

#### General Safety

- Only use the product as described in this manual, and keep it out of reach from children.
- To reduce the risk of fire, electric shock, or other injuries, always follow all instructions and safety guidelines.
- Use the product under the voltage within the specified range.
- Use the product on a flat surface to avoid tilting or dropping the aroma diffuser, which may cause water overflow from the diffuser or damage to the device.
- Do not block the air inlet or put objects into the air outlet, port or slot to avoid the risk of electric shock or fire.
- Do not use thinner benzyl alcohol, formaldehyde, acidic detergent, alcohol, etc. to wipe the product, so as not to damage the product or erase the logos on the product.
- Do not let the mist output face directly against furniture, appliances, clothes or walls.
- Do not touch, push, or press the ultrasonic vibrating plate directly with your hands to avoid damaging it and causing accidents or malfunctions.
- Do not unplug the power adapter or touch the power socket with wet hands to prevent electric shock.
- Stop using the product immediately if a strange odor, noise or an abnormal heat occurs during use.

- Do not open the top cover to add water or essential oils or move the diffuser while it is misting.
- Do not attempt to disassemble the diffuser or its components to avoid malfunction, fire, electric shock, injuries etc.
- This product is not suitable for young children or people who lack knowledge and experience in the use of this product.
- Disconnect the power supply : Unplug the power adapter when not in use. Always disconnect the power supply prior to beginning any servicing and cleaning operation.
- Do not use outdoors. Household use only. Not for commercial use.

CAUTION HOT: Do not touch the host while operating or if it stops running.

## Power Cord & Plug

- This device has a polarized plug (one blade is wider than the other). To reduce the risk of electric shock, this plug is intended to fit in a polarized outlet only one way. If the plug does not fit fully in the outlet, reverse the plug. If it still does not fit, contact a qualified electrician. Do not attempt to defeat this safety feature.
- Do not handle the power cord or plug with wet hands. Keep the power cord and plug away from liquids.

# Introduction

The GoveeLife Smart Aroma Diffuser has 300ml capacity, dazzling light, and white noise. The built-in ultrasonic atomizer can blow the essential oil dissolved in pure water into the air. This product is equipped with dazzling RGBIC lights and 21 pieces of built-in white noise, making it suitable for almost all indoor scenes such as living rooms, bedrooms, offices, etc. It can not only improve air quality but can also create atmosphere. It plays the role of a great partner that cares about your health and helps you relax.

## Included in the Box

Item	Quantity
Aroma Diffuser	1
Power Adapter	1
Cleaning Brush	1
User Manual	1
Quick Start Guide	1

# Part Names

- a. Mist Outlet
- b. DC Port
- c. Air Inlet & Speaker
- d. Power Button & Power Indicator
- e. Wi-Fi Indicator
- f. Top Cover

- g. Air Outlet
- h. Water Flap
- i. Ultrasonic Atomizer
- j. Power Adapter
- k. Cleaning Brush

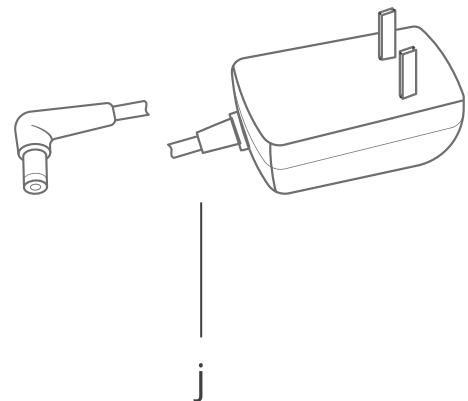
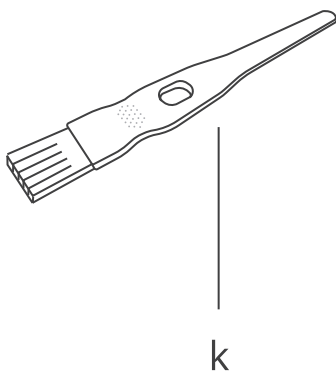
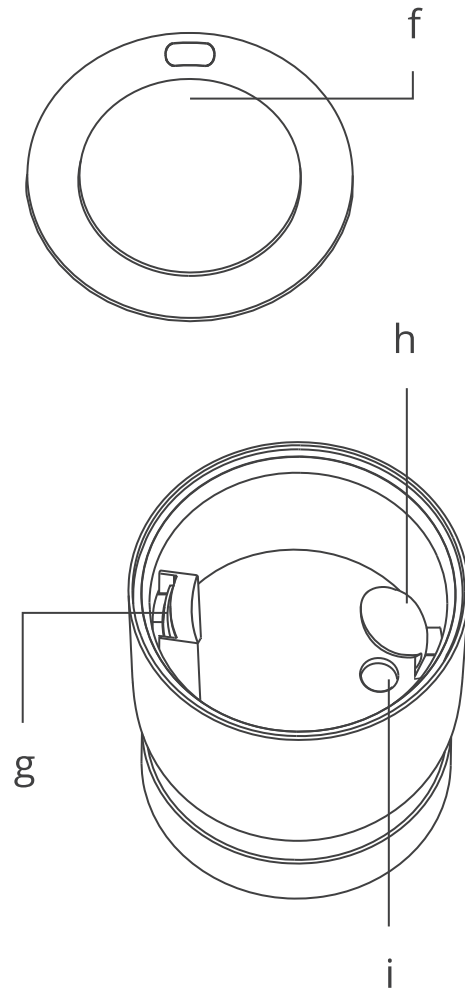
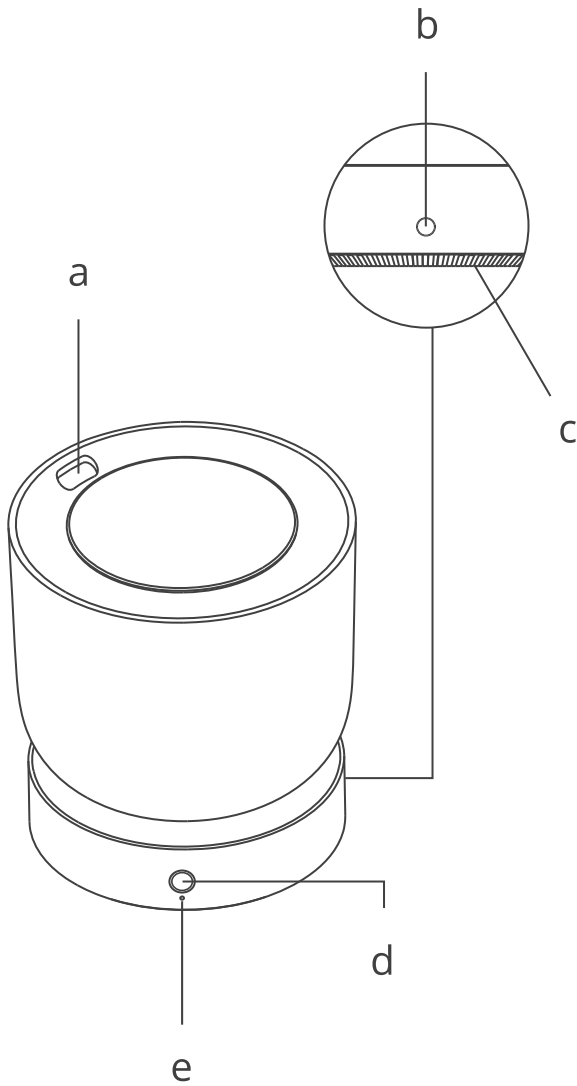

## Controls

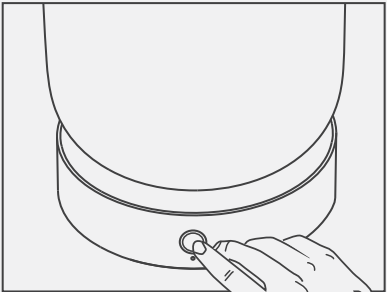
Power Button	Status	Operation	Command
	Standby	Short press	Power on
	Powered On	Short press	Next preset
	Powered On	Long press for 2 seconds	Power off
	Powered On / Standby	Long press for 10 seconds	Restore factory settings

### Note:

Before using the product, please make sure you are using the official power adapter and it is properly plugged into power.

## Indicator Status

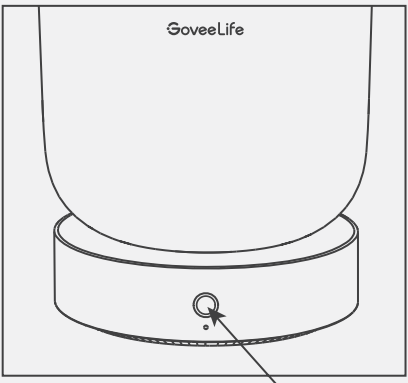
Indicator	Light Status	Working Status
	Solid White	Working
	Off	Standby / Powered Off
	Solid Red	Low on water
	Flashes Red	The top cover is not properly placed

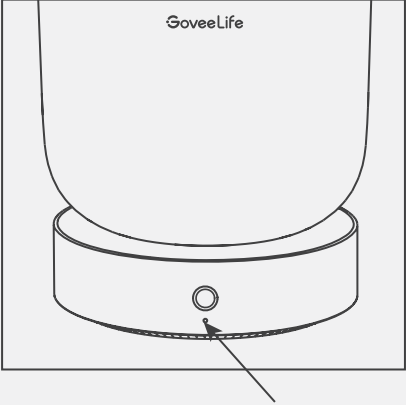

Wi-Fi Indicator	Solid White	Connected
	Off	Disconnected / Standby / Powered Off
	Slowly Flashes White	Ready to Connect
	Quickly Flashes White	Connecting

## Controls

### Preset Function

This aroma diffuser has 5 default presets (the best combination of mist, music, and light) that you can switch between via the button on the device. By adding the aroma diffuser to Govee Home App via Wi-Fi or Bluetooth, you can modify the order and number of presets, or create your own presets, including adjusting the mist level, light color, brightness, white noise music and volume, etc. Apply it to the product and enjoy.

### DIY Function

Connect this diffuser to Govee Home App via Wi-Fi or Bluetooth to enjoy DIY functions, such as adjusting the lighting, mist level, setting a timer, etc.

### Memory Function

The diffuser will remember its previous settings when powered off, including its mist level, sound level, light color, and brightness. These settings will become active again when the diffuser is turned back on.

# Operation

## Getting Started

1. Remove all packaging, protective foam, and stickers from the diffuser. Remove the Max Water Line sticker.
2. Place the diffuser on a hard, flat and waterproof surface and keep it at least 6 inches (15 cm) away from any walls.

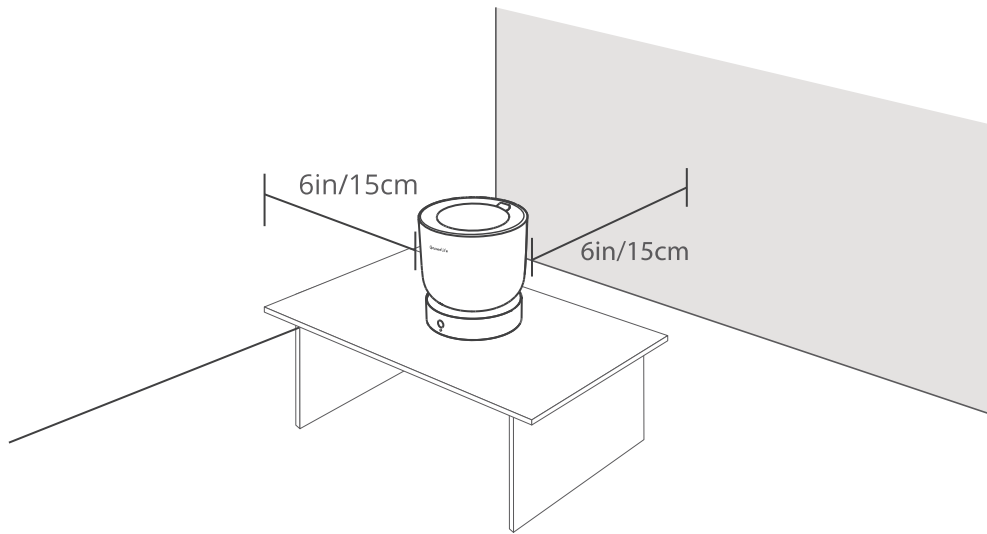

3. Keep fog away from walls, furniture, bedding and other appliances and electronics.

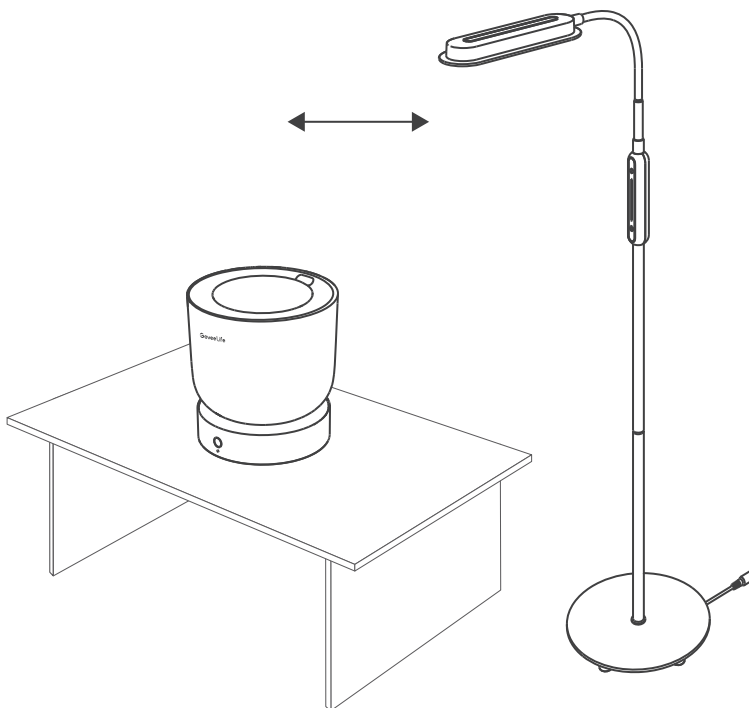

## Filling with Water

1. Fill the water tank from the top.

**Note:**

- Fill the tank with room-temperature water. Do not use warm or hot water.
- It is recommended to fill the tank with purified or distilled water instead of tap water, which may cause scales.
- Do not fill past the tank's Max Water Line.

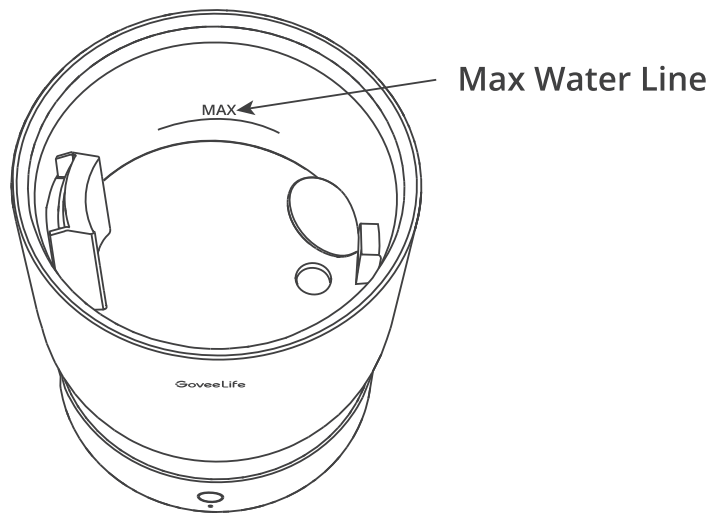

- Do not add water or essential oils into the air outlet.

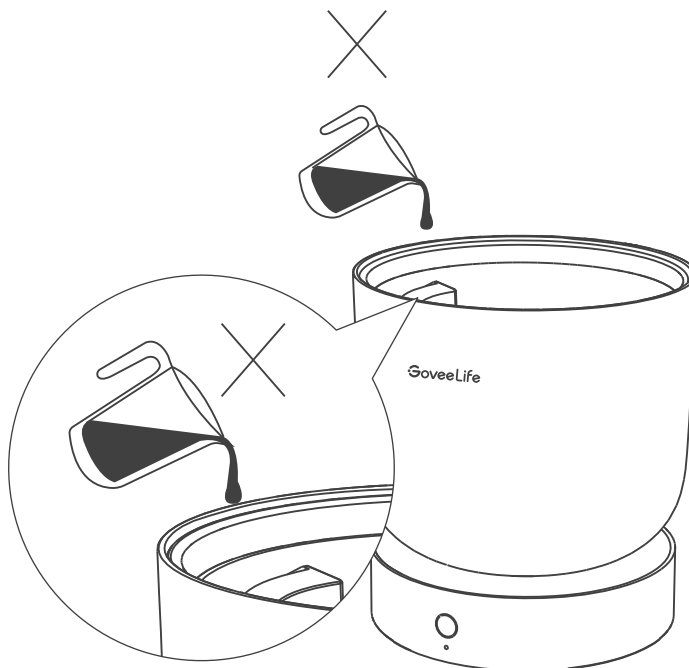

2. Add 5-10 drops of essential oils into the water tank (optional).  
Note: It is recommended to use pure essential oils for the best results.

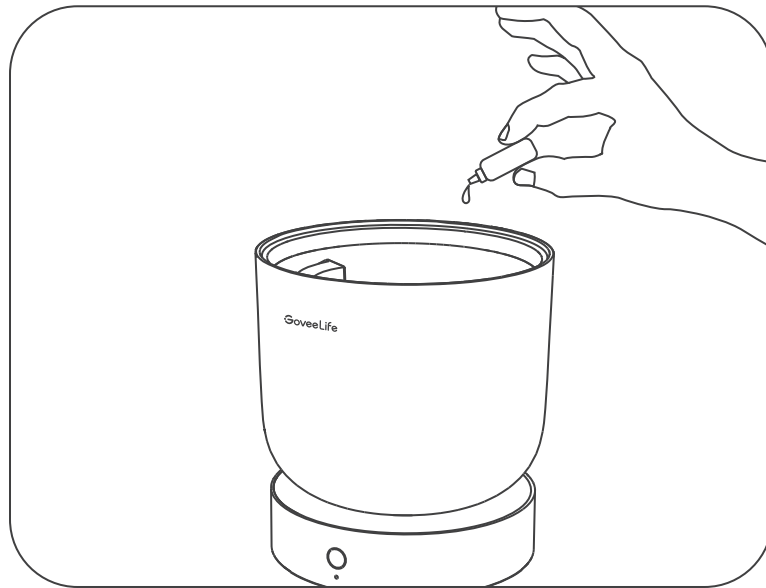

3. Place the cover back onto the water tank.
4. Plug the diffuser into power.

**Note:**

- Keep the diffuser stable while using.
- Make sure the mist outlet isn't blocked, otherwise, it may damage the diffuser.
- When the top cover is not placed properly, the diffuser will stop misting (the white noise and ambient light will still work). The indicator of the Power Button will flash red for 3 minutes. If the top cover is placed well within 3 minutes, the device will resume misting. The alert feature can be turned off in the app.
- When the water tank is waterless, the diffuser will stop misting (the white noise and ambient light will still work). The indicator of the Power Button will remain solid red for 3 minutes. If the water tank is refilled with enough water within 3 minutes (do not exceed the Max Water Line), the device will resume misting.

## Using Your Aroma Diffuser

### Power On

Plug into power and single click the Power Button to turn on the aroma diffuser. It will automatically resume working in the previous working mode.



## Switch Presets

When the diffuser is working, single click to switch to the next preset. Click repeatedly to cycle through the whole list of presets.

### Note:

- The diffuser has 5 default presets.
- You can modify, create, delete and save your own preset list in the app.
- You can save up to 12 presets and at least 3 onto the product. Please follow the in-app instructions.

## Power Off

Press and hold for 2 seconds to power off the diffuser.

**Note:** For volume adjustments, mist levels, light colors, schedule and more features, please download Govee Home App.

# Govee Home App

You can access more features using Govee Home App.

## Downloading Govee Home App

To download Govee Home App, scan the QR code or search for “Govee” in the Apple App Store® (iOS) or Google Play Store (Android).



Govee Home App



### Note:

- Choose “Allow” to the permissions requested when opening Govee Home App for the first time. These permissions allow the app’s features to function normally and are not used to record personal, private information.

- Due to ongoing updates, Govee Home App may be slightly different than shown in this manual. In case of any differences, always follow the in-app instructions.

## Pairing with Govee Home App

1. Turn on your smartphone's Bluetooth.
2. Open Govee Home App, tap the "+" icon in the top right corner and search for "H7161."
3. Tap the device icon and follow the on-screen instructions to complete pairing.

### Note:

- You can use Govee Home App to connect your Aroma Diffuser to Amazon Alexa or Google Assistant. Follow the in-app instructions to connect to each voice assistant.
- Govee Home App is being continually updated and its features do expand.

# Cleaning Instructions

## Maintenance Frequency

The diffuser should be cleaned after being used for a week or before being stored.

**Note:** Do not use detergents to clean the diffuser. Only use distilled white vinegar.

## Cleaning Steps

1. First, power off the diffuser and unplug it from power.
2. Open the top cover, pour out the superfluous water, pull out the water flap upwards and unscrew the cover counterclockwise.

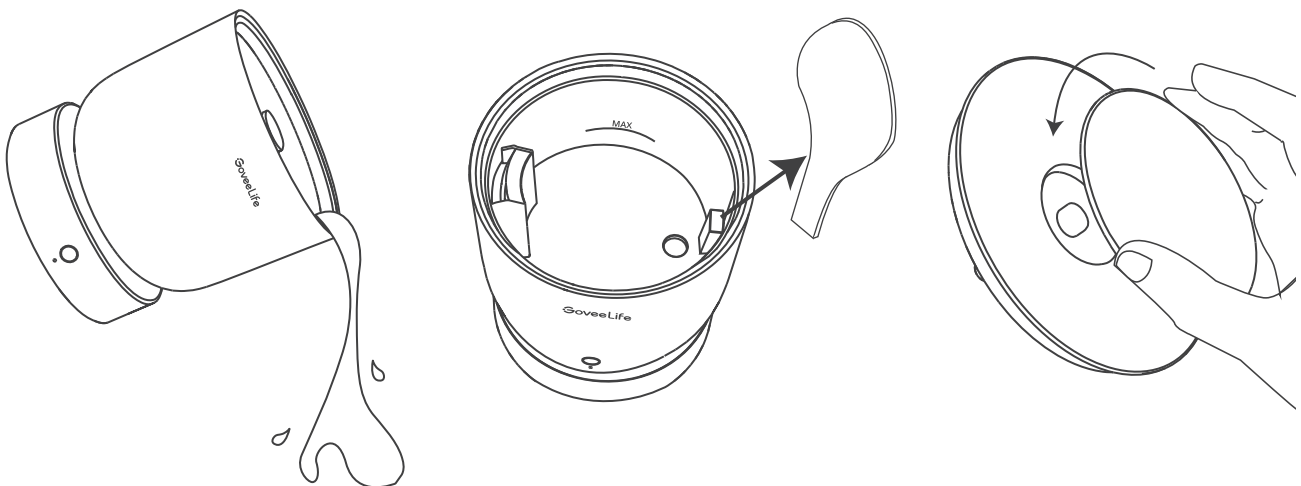

3. Wash the water tank and cover: Use a few drops of white vinegar or detergent diluted with warm water and scrub with the included cleaning brush or soft cloth.

**Note:** Before scrubbing with a soft cloth, please twist it dry in case any water drops enter the inside of the device through the air outlet and cause malfunction.

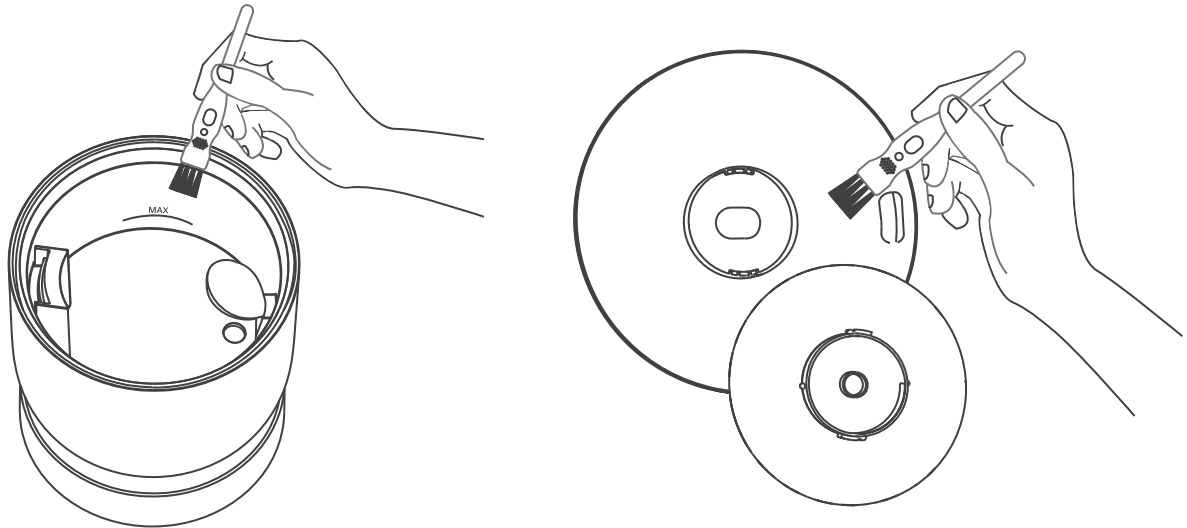

4. Dry all parts with a cloth completely before reassembling or storing the diffuser.
5. Put the water flap back into place and firmly screw the cover clockwise.

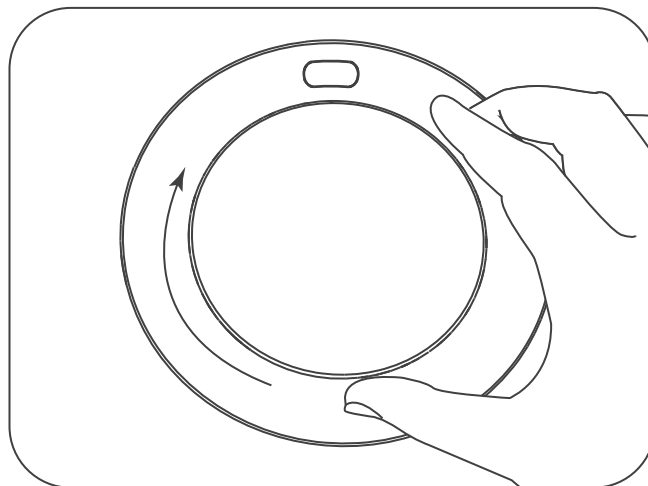

## Storing

When the aroma diffuser will not be used for a long time, please wash and dry the water tank, wipe it clean and store it in a cool place to avoid contact with direct sunlight.



# Troubleshooting

The troubleshooting section below is for solving frequently asked questions. If your problem persists, please contact Customer Support.

## For Smart Aroma Diffuser

Problem	Possible Solution
Diffuser doesn't turn on or it powers off frequently.	Make sure the power cable is securely connected and press the Power Button again.
Little or no mist comes out.	Add at least 100ml purified or distilled water to the water tank.
	Make sure the water is below the Max Water Line.
	Make sure the top cover is placed properly.
	Switch to the highest mist level.
	Make sure the air inlet and outlet haven't been clogged.
	Make sure the mist outlet hasn't been clogged.
	Make sure the diffuser is placed on a flat surface.
	The water temperature might be too low. Replace with room temperature water.
	If the water tank has been cleaned with detergent, use clean water to wash it completely to remove any leftover detergent.

The volume of the white noise is too low or the diffuser makes no sound.	Make sure the air inlet / speaker is not clogged.
	Switch to the highest volume.
Diffuser produces an unusual smell.	If the aroma diffuser has never been used before, unplug it, wash all parts and dry them in cool dry places for 12 hours.
	Clean the water tank.
Diffuser makes a loud or unusual noise.	Switch the mist output to a lower level.
	The aroma diffuser might have malfunctioned. Stop using it and contact Customer Support.
White dust appears around the diffuser.	It is recommended to use purified or distilled water to fill the aroma diffuser. Avoid using water with high mineral content, such as tap water.
Water leaks from the diffuser.	Do not shake the device body.
	Try to place the device on a flat surface.
	Check whether the water tank is leaking. If there is a water leak, please contact Customer Support.
Mold grows inside the diffuser.	Regularly clean the water tank.
Cannot smell the essential oils.	Add more essential oils.
	To get the best effect, it is recommended to use pure essential oils.

<p>Indicator of the Power Button flashes red.</p>	<p>The top cover is not placed properly. Correctly place the water tank on the base and properly place the top cover.</p>
<p>Indicator of the Power Button remains solid red.</p>	<p>The top cover is not placed properly or the water tank is lacking water. Correctly place the water tank on the base and properly place the top cover. Make sure there is enough pure water in the water tank that does not surpass the Max Water Line.</p>
<p>The ambient light cannot be turned on or adjusted through the app.</p>	<p>Check whether the aroma diffuser has connected with the app.</p>
	<p>If the diffuser has already connected with the app but the problem persists, please contact Customer Support.</p>

## For App & Connectivity

### 1. Cannot connect to Govee Home App.

- Make sure your smartphone is powered on and is not connected with other Bluetooth devices.
- Enable the smartphone's Location Services.
- Try connecting with another smartphone.
- Make sure your app is updated to the latest version.
- Make sure you connect to your Wi-Fi router's 2.4GHz network and that the network is working correctly.
- Make sure the Wi-Fi password you entered is correct.
- Shorten the distance between the diffuser, Wi-Fi router, and the smartphone.
- Make sure your diffuser and the Wi-Fi router are located away from appliances that produce electromagnetic radiation (e.g. microwave ovens, refrigerators, etc.)
- If you are using a VPN, try turning it off and then connecting the diffuser.
- Disable portal authentication for your Wi-Fi network. If portal authentication is enabled, this diffuser will not be able to access your Wi-Fi network, and setup will fail. Portal authentication means that you need to sign in to your Wi-Fi network through a web page before you can use the Internet.

### 2. Cannot find the device on Bluetooth Device Nearby page of the app.

- The diffuser may be connected with another smartphone. Disconnect it from the other smartphone first.

### 3. The diffuser is offline.

- Make sure the diffuser is plugged in and powered on, then refresh "My Devices" in Govee Home App by swiping down on the screen.
- Make sure your router is connected to the internet, and your smartphone's network connection is working.
- If the Wi-Fi password has been changed, the diffuser will automatically go offline. Try connecting it to the network again.
- Delete the offline diffuser from Govee Home App, then add and reconfigure the diffuser again in the app.

## After-Sales Service

 Warranty: 12-Month Limited Warranty

 Support: Lifetime Technical Support

 Email: support@govee.com

 Official Website: www.govee.com

 @Govee  @govee\_official  @govee.official

 @Goveeofficial  @Govee.smarthome

## Specifications

Model Name	H7161
Power Supply	AC 100-240V, 50/60Hz
Rated Power	14W
Water Tank Capacity	300ml
Max Run Time	15 Hours <b>Note:</b> The diffuser may run for a longer or shorter amount of time depending on the ambient temperature and humidity.
Noise Level	≤30 dB

# Compliance Information

## FCC Statement

This device complies with Part 18 of the FCC Rules.

This device complies with Part 15 of the FCC Rules. Operation is subject to the following two conditions: (1) This device may not cause harmful interference, and (2) This device must accept any interference received, including interference that may cause undesired operation.

Warning: Changes or modifications not expressly approved by the party responsible for compliance could void the user's authority to operate the equipment.

**Note:** This equipment has been tested and found to comply with the limits for a Class B digital device, pursuant to Part 15 of the FCC Rules. These limits are designed to provide reasonable protection against harmful interference in a residential installation. This equipment generates uses and can radiate radio frequency energy and, if not installed and used in accordance with the instructions, may cause harmful interference to radio communications. However, there is no guarantee that interference will not occur in a particular installation. If this equipment does cause harmful interference to radio or television reception, which can be determined by turning the equipment off and on, the user is encouraged to try to correct the interference by one or more of the following measures:

- (1) Reorient or relocate the receiving antenna.
- (2) Increase the separation between the equipment and receiver.
- (3) Connect the equipment into an outlet on a circuit different from that to which the receiver is connected.
- (4) Consult the dealer or an experienced radio/TV technician for help.

# FCC Radio Frequency Exposure Statement

This equipment complies with FCC radiation exposure limits set forth for an uncontrolled environment. This equipment should be installed and operated with minimum distance 20cm between the radiator & your body.

The following importer is the responsible party

Name: GOVEE MOMENTS (US) TRADING LIMITED

Address: 2501 Chatham Rd Suite R Springfield IL 62704

Email: support@govee.com

Contact information: <https://www.govee.com/support>



FOR INDOOR USE ONLY

POUR UNE UTILISATION EN INTÉRIEUR UNIQUEMENT

The Bluetooth® word mark and logos are registered trademarks owned by Bluetooth SIG, Inc. and any use of such marks by Shenzhen Qianyan Technology LTD.

The trademark GoveeLife has been authorised to Shenzhen Qianyan Technology LTD.

Copyright ©2021 Shenzhen Qianyan Technology LTD.

All Rights Reserved.



**Govee Home App**

For FAQs and more information,  
please visit: [www.govee.com](http://www.govee.com)