

FCC Test Report

Report No.: 2405U81213EC

Applicant: Shenzhen Qianyan Technology LTD

Address: No.3301, Block C, Section 1, ChuangzhiYuncheng Building, Liuxian Avenue, Xili Community, Xili Street, Nanshan District, Shenzhen, China

Product Name: Govee Outdoor Flood Lights 2

Product Model: H7058

Multiple Models: H7057

Trade Mark: Govee

FCC ID: 2A7VD-H7057

Standards: FCC CFR Title 47 Part 15C (§15.247)

Test Date: 2024-06-18 to 2024-09-10

Test Result: Complied

Report Date: 2024-09-10

Reviewed by:

Frank Yin

Approved by:

Jacob Kong

Frank Yin
Project Engineer

Jacob Kong
Manager

Prepared by:

World Alliance Testing & Certification (Shenzhen) Co., Ltd

No. 1002, East Block, Laobing Building, Xingye Road 3012, Xixiang street, Bao'an District, Shenzhen, Guangdong, People's Republic of China



This report may contain data that are not covered by the NVLAP accreditation and shall be marked with an asterisk “★”

Announcement

1. This test report shall not be reproduced except in full, without the written approval of World Alliance Testing & Certification (Shenzhen) Co., Ltd
2. The results in this report apply only to the sample tested.
3. This sample tested is in compliance with the limits of the above regulation.
4. This report must not be used by the client to claim product certification, approval, or endorsement by NVLAP, NIST, or any agency of the U.S. Government.
5. The information marked “#” is provided by the applicant, the laboratory is not responsible for its authenticity and this information can affect the validity of the result in the test report. Customer model name, addresses, names, trademarks etc. are included.

Revision History

Version No.	Issued Date	Description
00	2024-09-10	Original

Contents

1	General Information	4
1.1	Client Information	4
1.2	Product Description of EUT	4
1.3	Antenna information	4
1.4	Related Submittal(s)/Grant(s).....	5
1.5	Measurement Uncertainty	5
1.6	Laboratory Location.....	5
1.7	Test Methodology	5
2	Description of Measurement.....	6
2.1	Test Configuration.....	6
2.2	Test Auxiliary Equipment	6
2.3	Interconnecting Cables.....	6
2.4	Block Diagram of Connection between EUT and AE	7
2.5	Test Setup.....	7
2.6	Test Procedure	9
2.7	Measurement Method.....	10
2.8	Measurement Equipment	11
3	Test Results	12
3.1	Test Summary.....	12
3.2	Limit	13
3.3	AC Line Conducted Emissions Test Data.....	14
3.4	Radiated emission Test Data.....	20
3.5	RF Conducted Test Data	36
3.5.1	6 dB Emission Bandwidth and 99% Occupied Bandwidth.....	36
3.5.2	Maximum Conducted Peak Output Power.....	36
3.5.3	Power Spectral Density.....	36
3.5.4	100 kHz Bandwidth of Frequency Band Edge	36
3.5.5	Duty Cycle.....	36
4	Test Setup Photo.....	42
5	E.U.T Photo.....	43

1 General Information

1.1 Client Information

Applicant:	Shenzhen Qianyan Technology LTD
Address:	No.3301, Block C, Section 1, ChuangzhiYuncheng Building, Liuxian Avenue, Xili Community, Xili Street, Nanshan District, Shenzhen, China
Manufacturer:	Shenzhen Qianyan Technology LTD
Address:	No.3301, Block C, Section 1, ChuangzhiYuncheng Building, Liuxian Avenue, Xili Community, Xili Street, Nanshan District, Shenzhen, China

1.2 Product Description of EUT

The EUT is Govee Outdoor Flood Lights 2 that contains BLE and 2.4G WLAN radios, this report covers the full testing of the BLE radio.

Sample Serial Number	2N1P-9 & 2N1P-1 for CE&RE test, 2N1P-11 for RF conducted test (assigned by WATC)
Sample Received Date	2024-06-17
Sample Status	Good Condition
Frequency Range	2402MHz - 2480MHz(BLE1M)
Maximum Conducted Peak Output Power	-6.20dBm
Modulation Technology	GFSK
Spatial Streams	SISO (1TX, 1RX)
Antenna Gain [#]	3.77dBi
Power Supply	DC 24V from adapter
Adapter Information	For model H7057: Adapter model: BI48G-240200-AdU Input: AC100-240V, 50/60Hz, 1.4A Output: DC 24V/2.0A For model H7058: Adapter model: SOY-2400300US-306 Input: AC100-240V, 50/60Hz, 1.8A Output: DC 24V/3.0A 72.0W
Modification	Sample No Modification by the test lab

1.3 Antenna information

15.203 requirement:	
An intentional radiator shall be designed to ensure that no antenna other than that furnished by the responsible party shall be used with the device. The use of a permanently attached antenna or of an antenna that uses a unique coupling to the intentional radiator, the manufacturer may design the unit so that a broken antenna can be replaced by the user, but the use of a standard antenna jack or electrical connector is prohibited.	
Device Antenna information:	
The BLE antenna is an internal antenna which cannot replace by end-user, please see product internal photos for details.	

1.4 Related Submittal(s)/Grant(s)

No related submittal(s)/Grant(s)

1.5 Measurement Uncertainty

Parameter		Expanded Uncertainty (Confidence of 95%(U = 2Uc(y)))
AC Power Lines Conducted Emissions		±3.14dB
Emissions, Radiated	Below 30MHz	±2.78dB
	Below 1GHz	±4.84dB
	Above 1GHz	±5.44dB
Emissions, Conducted		1.75dB
Conducted Power		0.74dB
Frequency Error		150Hz
Bandwidth		0.34%
Power Spectral Density		0.74dB

Note: The extended uncertainty given in this report is obtained by combining the standard uncertainty times the coverage factor K with the 95% confidence interval. Otherwise required by the applicant or Product Regulations, Decision Rule in this report did not consider the uncertainty.

1.6 Laboratory Location

World Alliance Testing & Certification (Shenzhen) Co., Ltd

No. 1002, East Block, Laobing Building, Xingye Road 3012, Xixiang street, Bao'an District, Shenzhen, Guangdong, People's Republic of China

Tel: +86-755-29691511, Email: qa@watc.com.cn

The lab has been recognized as the FCC accredited lab under the KDB 974614 D01 and is listed in the FCC Public Access Link (PAL) database, FCC Registration No. : 463912, the FCC Designation No. : CN5040.

The lab has been recognized by Innovation, Science and Economic Development Canada to test to Canadian radio equipment requirements, the CAB identifier: CN0160.

1.7 Test Methodology

FCC CFR 47 Part 2

FCC CFR 47 Part 15

KDB 558074 D01 DTS Meas Guidance v05r02

ANSI C63.10-2013

2 Description of Measurement

2.1 Test Configuration

Operating channels:					
Channel No.	Frequency (MHz)	Channel No.	Frequency (MHz)	Channel No.	Frequency (MHz)
0	2402	19	2440	38	2478
1	2404	20	2442	39	2480
...	/	/
18	2438	/	/

According to ANSI C63.10-2013 chapter 5.6.1 Table 11 requirement, select lowest channel, middle channel, and highest channel in the frequency range in which device operates for testing. The detailed frequency points are as follows:

Lowest channel		Middle channel		Highest channel	
Channel No.	Frequency (MHz)	Channel No.	Frequency (MHz)	Channel No.	Frequency (MHz)
0	2402	19	2440	39	2480

Test Mode:				
Transmitting mode:	Keep the EUT in continuous transmitting with modulation			
Exercise software [#] :	UartAssist			
Mode	Data rate	Power Level Setting [#]		
		Low Channel	Middle Channel	High Channel
BLE 1M	1Mbps	0x05	0x05	0x05

The exercise software and the maximum power setting that provided by manufacturer.

Worst-Case Configuration:
For radiated emissions, EUT was investigated in three orthogonal orientation, the worst-case orientation was recorded in report
For AC power line conducted emission and radiated emission 9kHz-1GHz and above 18GHz were performed with the EUT transmits at the channel with highest output power as worst-case scenario.

2.2 Test Auxiliary Equipment

Manufacturer	Description	Model	Serial Number
/	/	/	/

2.3 Interconnecting Cables

Manufacturer	Description	Length(m)	From	To
Unknown	DC Power Cable	2.0	Adapter	Controller
Unknown	DC Power Cable	2.0	Controller	LEDs

2.4 Block Diagram of Connection between EUT and AE

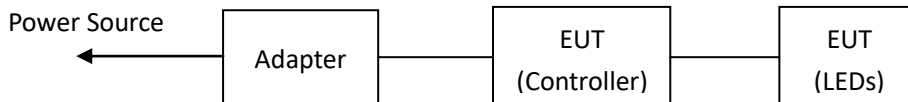

Note: for reference only, the actual connection setup used for testing please refer to the test photos.

2.5 Test Setup

1) Conducted emission measurement:

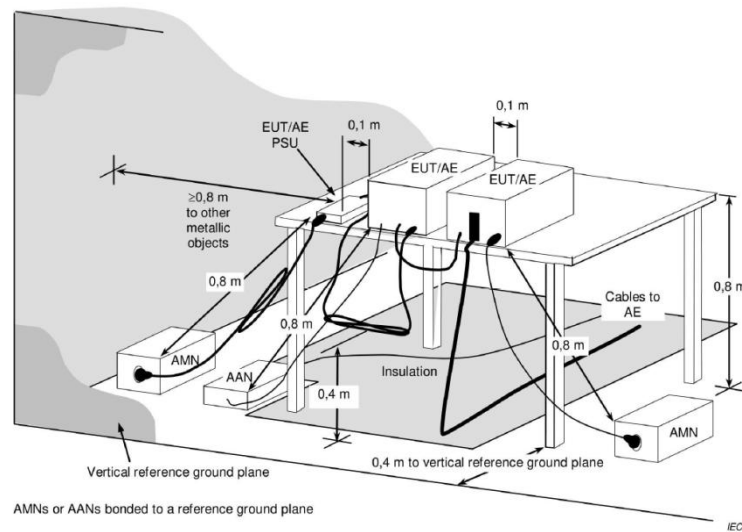

Note: The 0.8 m distance specified between EUT/AE/PSU and AMN/AAN, is applicable only to the EUT being measured. If the device is AE then it shall be >0.8 m.

2) Radiated emission measurement:

Below 30MHz (3m SAC)

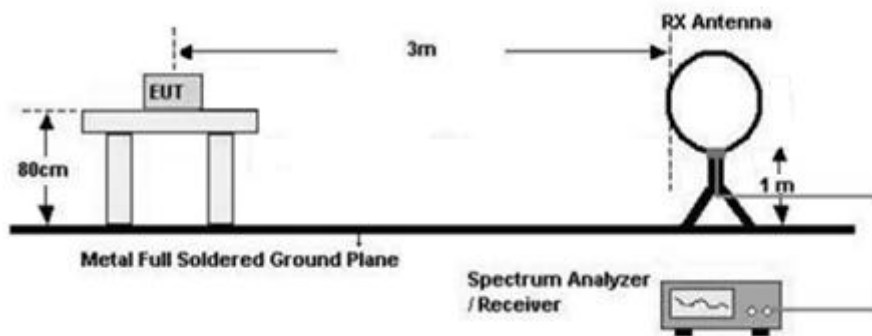

30MHz-1GHz (3m SAC)

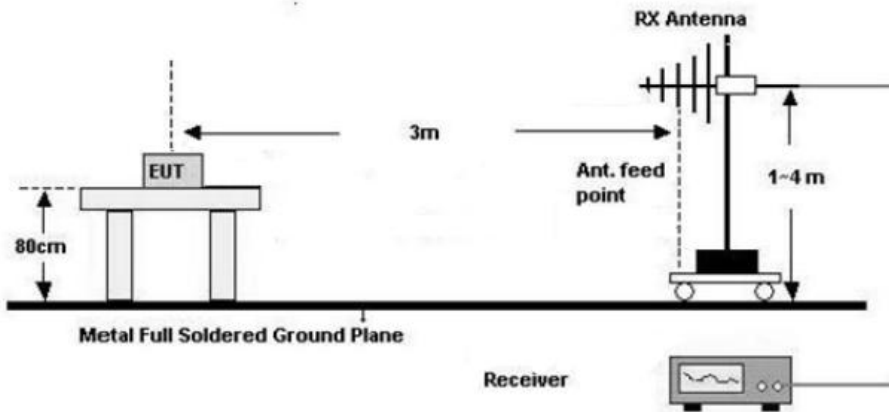

1GHz-18GHz(3m FAC)

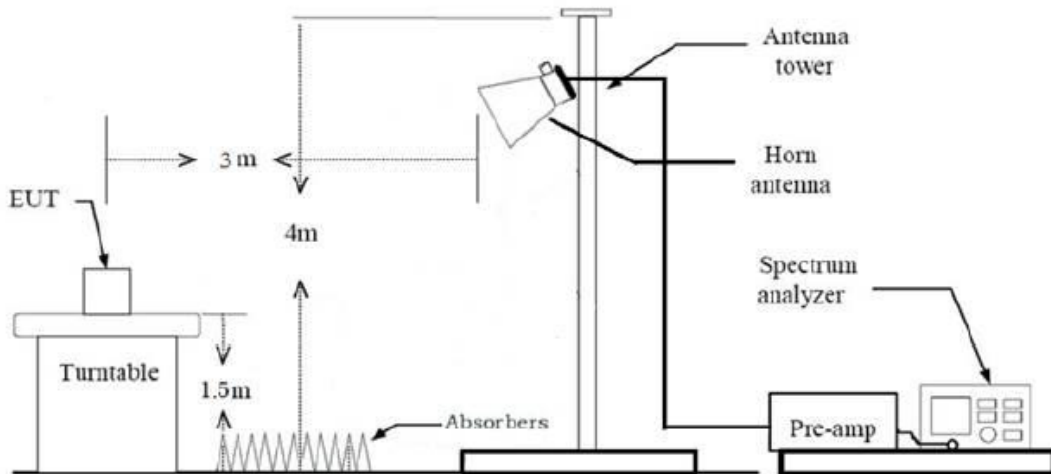

Above 18GHz (3m FAC)

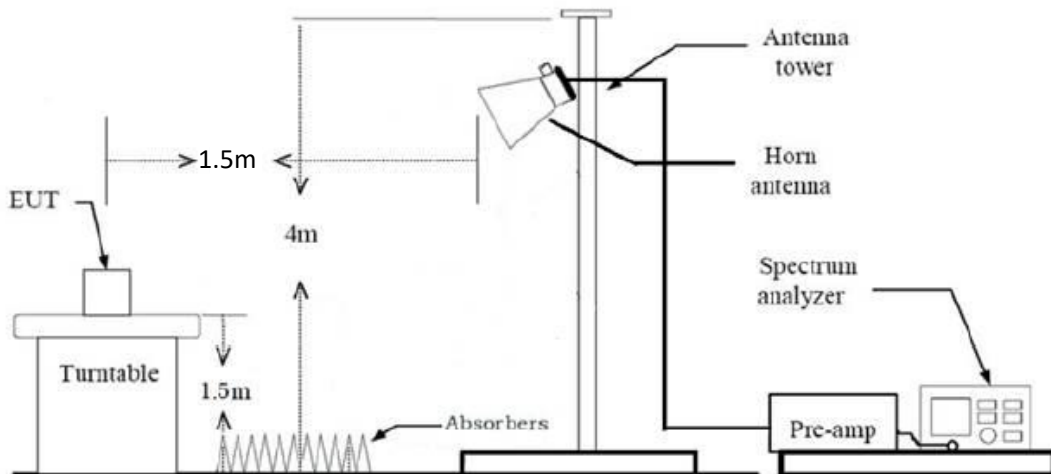

3) RF Conducted Test

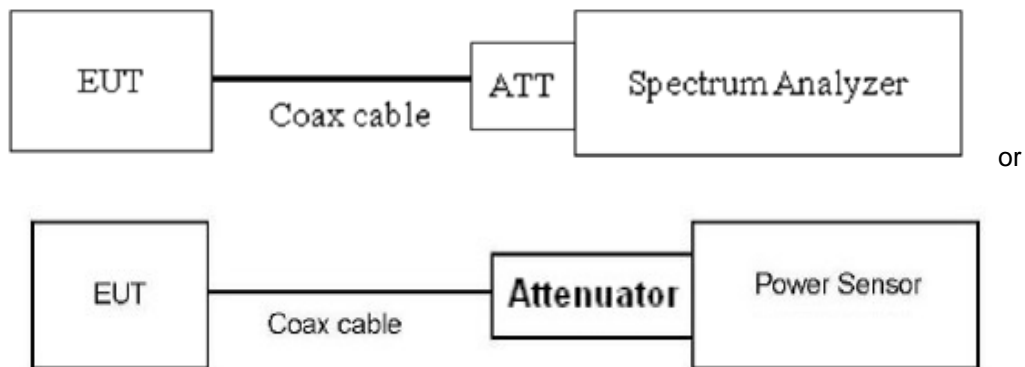

2.6 Test Procedure

Conducted emission:

1. The E.U.T is placed on a non-conducting table 40cm from the vertical ground plane and 80cm above the horizontal ground plane (Please refer to the block diagram of the test setup and photographs).
2. Both sides of A.C. line are checked for maximum conducted interference. In order to find the maximum emission, the relative positions of equipment and all of the interface cables must be changed according to ANSI C63.10 on conducted measurement.
3. Line conducted data is recorded for both Line and Neutral

Radiated Emission Procedure:

a) For below 30MHz

1. All measurements were made at a test distance of 3 m. The measured data was extrapolated from the test distance (3m) to the specification distance (300 m from 9-490 kHz and 30 m from 490 kHz- 30 MHz) to clearly show the relative levels of fundamental and spurious emissions and demonstrate compliance with the requirement that the level of any spurious emissions be below the level of the intentionally transmitted signal. The extrapolation factor for the limits were $40 \cdot \log(\text{test distance} / \text{specification distance})$.
2. Loop antenna use, investigation was done on the three antenna orientations (parallel, perpendicular, ground-parallel)

b) For 30MHz-1GHz:

1. The EUT was placed on the tabletop of a rotating table 0.8 m the ground at a 3 m semi anechoic chamber. The measurement distance from the EUT to the receiving antenna is 3 m.
2. EUT works in each mode of operation that needs to be tested. The highest signal levels relative to the limit shall be determined by rotating the EUT from 0° to 360° and with varying the measurement antenna height between 1 m and 4 m in vertical and horizontal polarizations.

c) For above 1GHz:

1. The EUT was placed on the tabletop of a rotating table 1.5 m the ground at a 3 m fully anechoic room. The measurement distance from the EUT to the receiving antenna is 3 m (1-18GHz) and 1.5 m (above

18GHz).

2. EUT works in each mode of operation that needs to be tested, and having the EUT continuously working. The highest signal levels relative to the limit shall be determined by rotating the EUT from 0° to 360° and with varying the measurement antenna height between 1 m and 4 m in vertical and horizontal polarizations.
3. Open the test software to control the test antenna and test turntable. Perform the test, save the test results, and export the test data.
4. Base on FCC 15.31 (f) (2): measurements may be performed at a distance closer than that specified in the regulations; however, an attempt should be made to avoid making measurements in the near field.

RF Conducted Test:

1. The antenna port of EUT was connected to the RF port of the test equipment (Power Meter or Spectrum analyzer) through Attenuator and RF cable.
2. The cable assembly insertion loss of 6.5dB (including 6.0dB Attenuator and 0.5dB cable) was entered as an offset in the power meter. Note: Actual cable loss was unavailable at the time of testing, therefore a loss of 0.5dB was assumed as worst case. This was later verified to be true by laboratory. (if the RF cable provided by client, the cable loss declared by client)
3. The EUT is keeping in continuous transmission mode and tested in all modulation modes.

2.7 Measurement Method

Description of Test	Measurement Method
AC Line Conducted Emissions	ANSI C63.10-2013 Section 6.2
Maximum Conducted Output Power	ANSI C63.10-2013 Section 11.9.1.1
Power Spectral Density	ANSI C63.10-2013 Section 11.10.2
6 dB Emission Bandwidth	ANSI C63.10-2013 Section 11.8.1
99% Occupied Bandwidth	ANSI C63.10-2013 Section 6.9.3
100kHz Bandwidth of Frequency Band Edge	ANSI C63.10-2013 Section 6.10
Radiated emission	ANSI C63.10-2013 Section 11.11&11.12.1
Duty Cycle	ANSI C63.10-2013 Section 11.6

2.8 Measurement Equipment

Manufacturer	Description	Model	Management No.	Calibration Date	Calibration Due Date
AC Line Conducted Emission Test					
ROHDE& SCHWARZ	EMI TEST RECEIVER	ESR	101817	2023/7/3	2024/7/2
R&S	LISN	ENV216	101748	2023/8/1	2024/7/31
N/A	Coaxial Cable	NO.12	N/A	2023/7/3	2024/7/2
Farad	Test Software	EZ-EMC	Ver. EMEC-3A1	/	/
Radiated Emission Test					
R&S	EMI test receiver	ESR3	102758	2023/7/3	2024/7/2
ROHDE& SCHWARZ	SPECTRUM ANALYZER	FSV40-N	101608	2023/7/3	2024/7/2
SONOMA INSTRUMENT	Low frequency amplifier	310	186014	2023/7/12	2024/7/11
COM-POWER	preamplifier	PAM-118A	18040152	2023/8/21	2024/8/20
COM-POWER	Amplifier	PAM-840A	461306	2023/8/8	2024/8/7
BACL	Loop Antenna	1313-1A	4010611	2024/2/7	2027/2/6
SCHWARZBECK	Log - periodic wideband antenna	VULB 9163	9163-872	2023/7/7	2024/7/6
Astro Antenna Ltd	Horn antenna	AHA-118S	3015	2023/7/6	2024/7/5
Ducommun technologies	Horn Antenna	ARH-4223-02	1007726-03	2023/7/10	2024/7/9
Oulitong	Band Reject Filter	OBSF-2400-248 3.5-50N	OE02103119	2023/9/15	2024/9/14
N/A	Coaxial Cable	N/A	NO.9	2023/8/8	2024/8/7
N/A	Coaxial Cable	N/A	NO.10	2023/8/8	2024/8/7
N/A	Coaxial Cable	N/A	NO.11	2023/8/8	2024/8/7
Audix	Test Software	E3	191218 V9	/	/
RF Conducted Test					
ROHDE& SCHWARZ	SPECTRUM ANALYZER	FSU-26	200680/026	2023/7/12	2024/7/11
ROHDE& SCHWARZ	SPECTRUM ANALYZER	FSU-26	200680/026	2024/6/4	2025/6/3
narda	6dB attenuator	603-06-1	N/A	2023/7/26	2024/7/25
narda	6dB attenuator	603-06-1	N/A	2024/6/4	2025/6/3

Note: All equipment is calibrated with valid calibrations. Each measurement data is traceable to the national or International standards.

3 Test Results

3.1 Test Summary

FCC Rules	Description of Test	Result
§15.203	Antenna Requirement	Compliance
§15.207 (a)	AC Line Conducted Emissions	Compliance
§15.247(b)(3)	Maximum Conducted Output Power	Compliance
§15.247(e)	Power Spectral Density	Compliance
§15.247 (a)(2)	6 dB Emission Bandwidth	Compliance
-	99% Occupied Bandwidth	Report only
§15.247(d)	100kHz Bandwidth of Frequency Band Edge	Compliance
§15.205, §15.209, §15.247(d)	Radiated emission	Compliance
-	Duty Cycle	Report only

3.2 Limit

Test items	Limit
AC Line Conducted Emissions	See details §15.207 (a)
Conducted Output Power	For systems using digital modulation in the 902-928 MHz, 2400-2483.5 MHz, and 5725-5850 MHz bands: 1 Watt.
6dB Emission Bandwidth	The minimum 6 dB bandwidth shall be at least 500 kHz.
Power Spectral Density	For digitally modulated systems, the power spectral density conducted from the intentional radiator to the antenna shall not be greater than 8 dBm in any 3 kHz band during any time interval of continuous transmission.
Spurious Emissions, 100kHz Bandwidth of Frequency Band Edge	In any 100 kHz bandwidth outside the frequency band in which the spread spectrum or digitally modulated intentional radiator is operating, the radio frequency power that is produced by the intentional radiator shall be at least 20 dB below that in the 100 kHz bandwidth within the band that contains the highest level of the desired power, based on either an RF conducted or a radiated measurement, provided the transmitter demonstrates compliance with the peak conducted power limits. If the transmitter complies with the conducted power limits based on the use of RMS averaging over a time interval, as permitted under paragraph (b)(3) of this section, the attenuation required under this paragraph shall be 30 dB instead of 20 dB. Attenuation below the general limits specified in §15.209(a) is not required. In addition, radiated emissions which fall in the restricted bands, as defined in §15.205(a), must also comply with the radiated emission limits specified in §15.209(a) (see §15.205(c)).

3.3 AC Line Conducted Emissions Test Data

Test Date:	2024-06-18	Test By:	Lirou Li
Environment condition:	Temperature: 23.5°C; Relative Humidity:58%; ATM Pressure: 101.2kPa		

Model: H7058

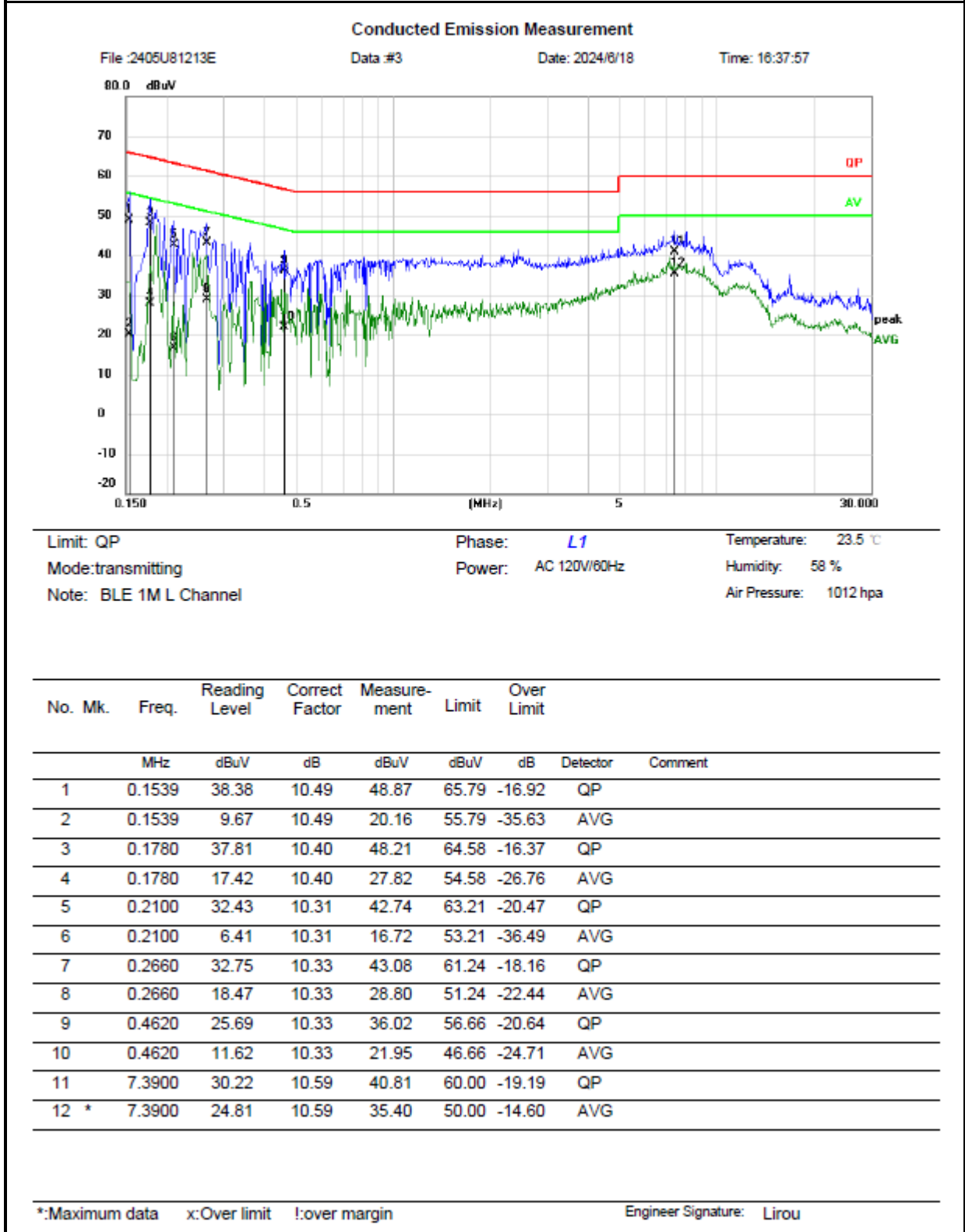

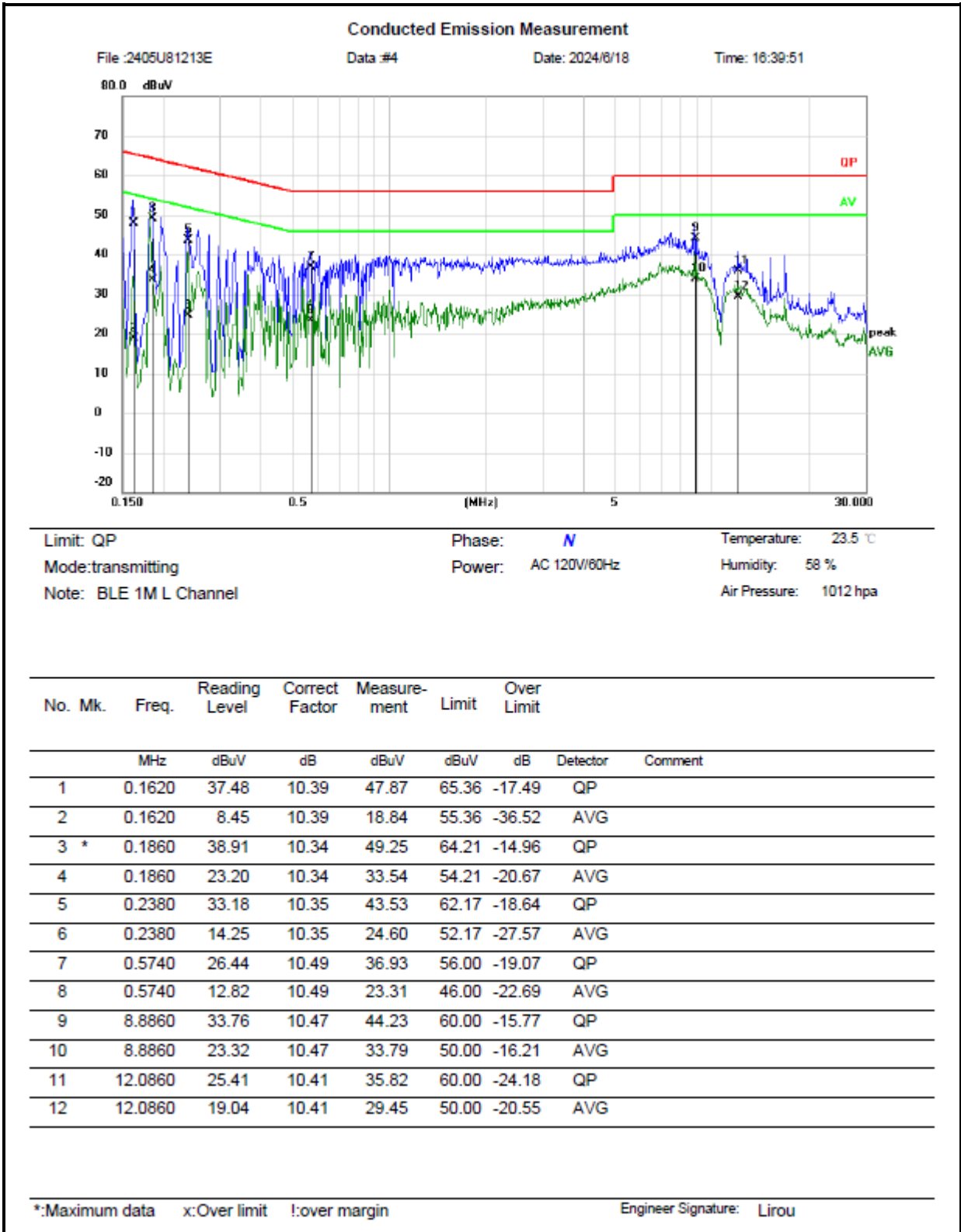

Test Date:	2024-06-19	Test By:	Lirou Li
Environment condition:	Temperature: 23°C; Relative Humidity:59%; ATM Pressure: 101.2kPa		

Model: H7057

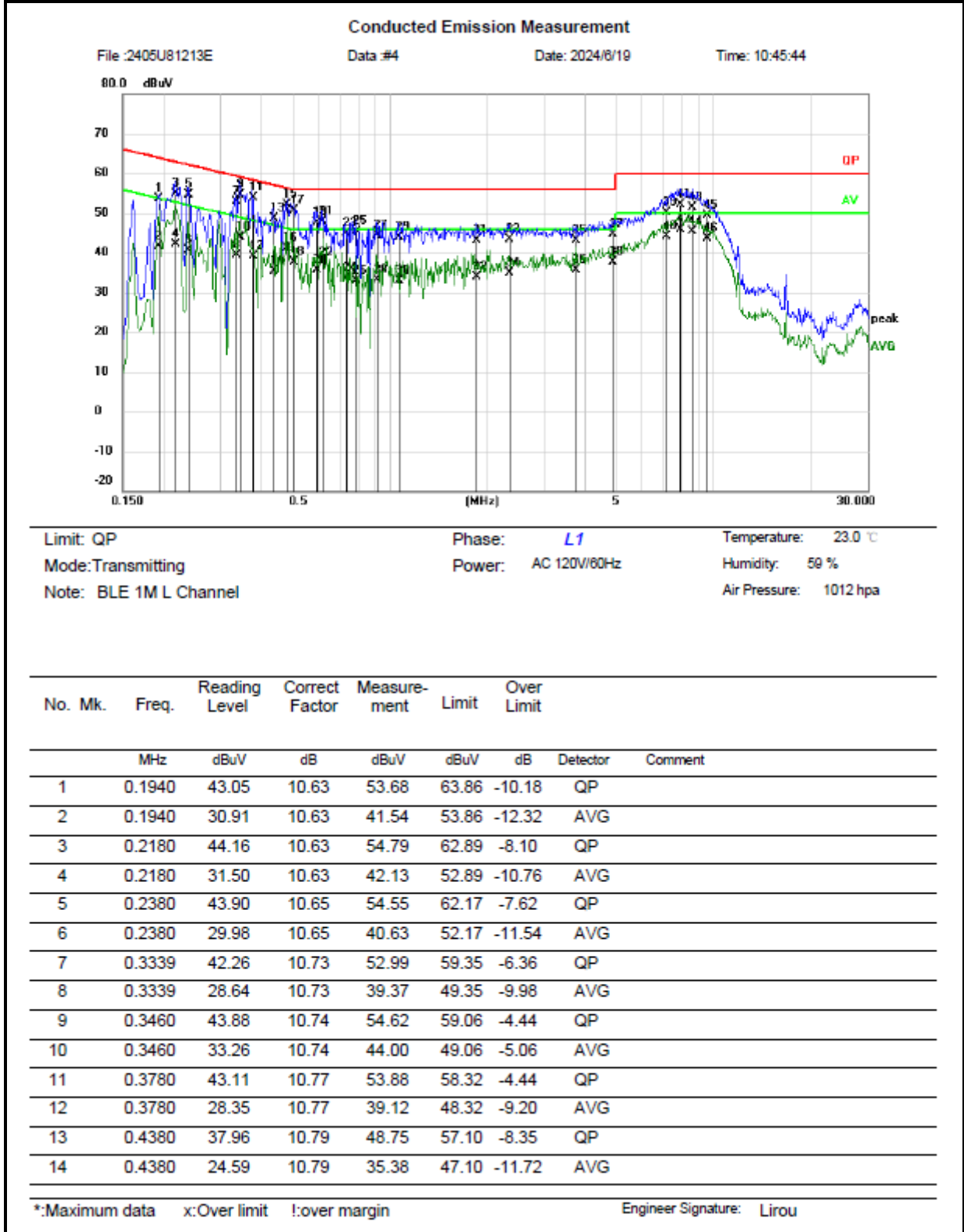

Limit: QP Phase: *L1* Temperature: 23.0 °C
 Mode: Transmitting Power: AC 120V/60Hz Humidity: 59 %
 Note: BLE 1M L Channel Air Pressure: 1012 hpa

No.	Mk.	Freq.	Reading Level	Correct Factor	Measurement	Limit	Over Limit	Detector	Comment
		MHz	dBuV	dB	dBuV	dBuV	dB		
15		0.4820	41.22	10.81	52.03	56.30	-4.27	QP	
16		0.4820	30.24	10.81	41.05	46.30	-5.25	AVG	
17		0.5060	39.78	10.81	50.59	56.00	-5.41	QP	
18		0.5060	26.85	10.81	37.66	46.00	-8.34	AVG	
19		0.5940	36.82	10.84	47.66	56.00	-8.34	QP	
20		0.5940	24.81	10.84	35.65	46.00	-10.35	AVG	
21		0.6180	37.05	10.84	47.89	56.00	-8.11	QP	
22		0.6180	26.58	10.84	37.42	46.00	-8.58	AVG	
23		0.7340	33.90	10.88	44.78	56.00	-11.22	QP	
24		0.7340	22.75	10.88	33.63	46.00	-12.37	AVG	
25		0.7900	34.48	10.93	45.41	56.00	-10.59	QP	
26		0.7900	21.90	10.93	32.83	46.00	-13.17	AVG	
27		0.9180	33.33	11.01	44.34	56.00	-11.66	QP	
28		0.9180	22.09	11.01	33.10	46.00	-12.90	AVG	
29		1.0660	32.96	11.02	43.98	56.00	-12.02	QP	
30		1.0660	21.78	11.02	32.80	46.00	-13.20	AVG	
31		1.8500	32.45	10.58	43.03	56.00	-12.97	QP	
32		1.8500	23.30	10.58	33.88	46.00	-12.12	AVG	
33		2.3380	32.70	10.59	43.29	56.00	-12.71	QP	
34		2.3380	24.32	10.59	34.91	46.00	-11.09	AVG	
35		3.7660	31.97	11.04	43.01	56.00	-12.99	QP	
36		3.7660	24.50	11.04	35.54	46.00	-10.46	AVG	
37		4.8940	33.38	11.14	44.52	56.00	-11.48	QP	
38		4.8940	26.55	11.14	37.69	46.00	-8.31	AVG	
39		7.1380	38.98	11.09	50.07	60.00	-9.93	QP	
40		7.1380	33.07	11.09	44.16	50.00	-5.84	AVG	
41		7.9300	41.12	10.91	52.03	60.00	-7.97	QP	
42 *		7.9300	35.04	10.91	45.95	50.00	-4.05	AVG	
43		8.6300	40.74	10.75	51.49	60.00	-8.51	QP	
44		8.6300	34.56	10.75	45.31	50.00	-4.69	AVG	
45		9.5659	38.76	10.52	49.28	60.00	-10.72	QP	
46		9.5659	33.06	10.52	43.58	50.00	-6.42	AVG	

*:Maximum data x:Over limit !:over margin

Engineer Signature: Lirou

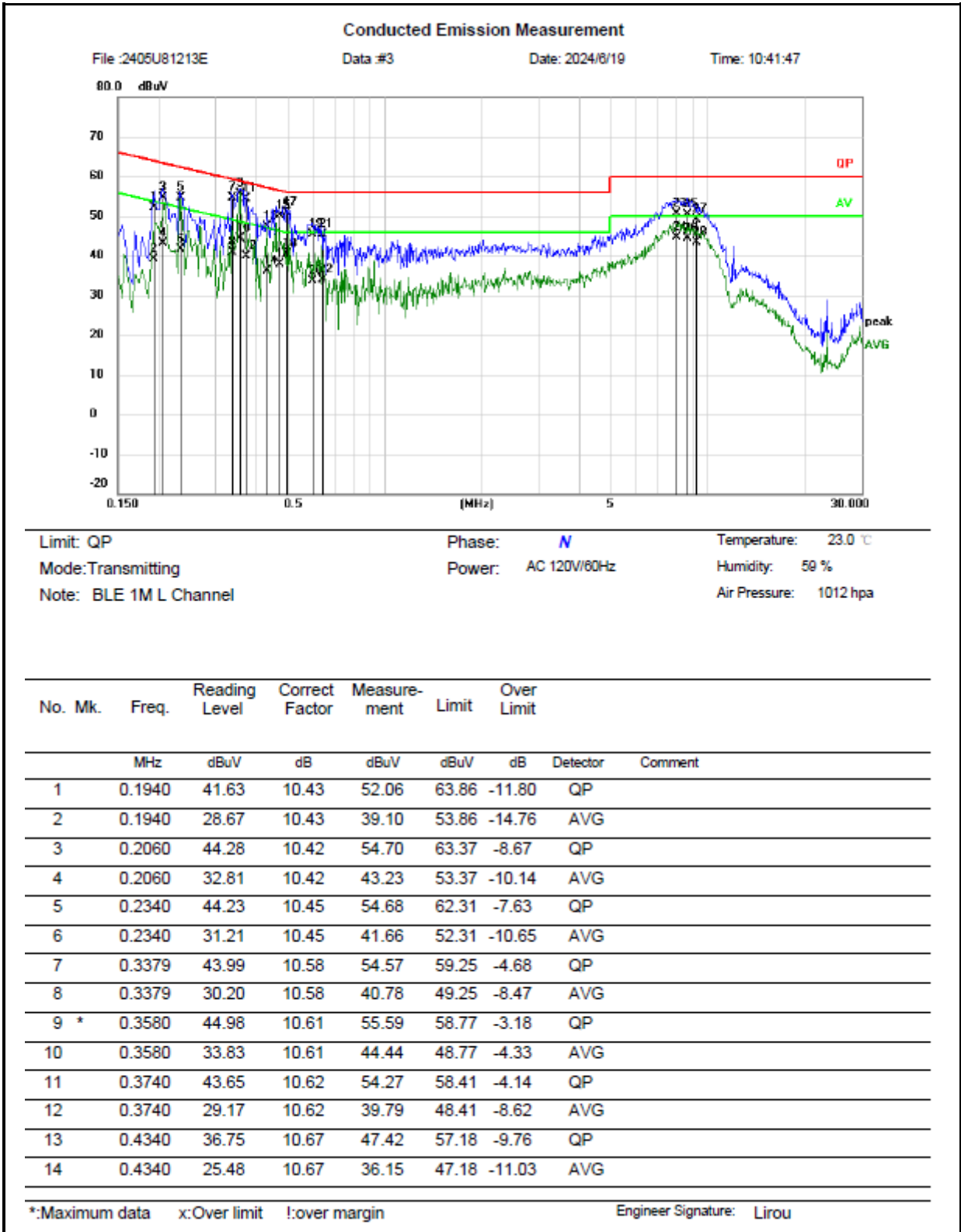

Limit: QP Phase: **N** Temperature: 23.0 °C
 Mode: Transmitting Power: AC 120V/60Hz Humidity: 50 %
 Note: BLE 1M L Channel Air Pressure: 1012 hpa

No.	Mk.	Freq.	Reading Level	Correct Factor	Measurement	Limit	Over Limit	Detector	Comment
		MHz	dBuV	dB	dBuV	dBuV	dB		
15		0.4740	39.55	10.69	50.24	56.44	-6.20	QP	
16		0.4740	27.28	10.69	37.97	46.44	-8.47	AVG	
17		0.4980	40.05	10.71	50.76	56.03	-5.27	QP	
18		0.4980	29.68	10.71	40.39	46.03	-5.64	AVG	
19		0.5980	34.79	10.64	45.43	56.00	-10.57	QP	
20		0.5980	23.00	10.64	33.64	46.00	-12.36	AVG	
21		0.6419	34.83	10.61	45.44	56.00	-10.56	QP	
22		0.6419	23.20	10.61	33.81	46.00	-12.19	AVG	
23		7.9780	39.81	10.73	50.54	60.00	-9.46	QP	
24		7.9780	33.95	10.73	44.68	50.00	-5.32	AVG	
25		8.6459	39.62	10.73	50.35	60.00	-9.65	QP	
26		8.6459	33.53	10.73	44.26	50.00	-5.74	AVG	
27		9.2140	38.34	10.73	49.07	60.00	-10.93	QP	
28		9.2140	32.74	10.73	43.47	50.00	-6.53	AVG	

*:Maximum data x:Over limit !:over margin

Engineer Signature: Lirou

Remark:

Measurement (dBuV)= Reading Level (dBuV) + Correct Factor(dB)

Correct Factor(dB)= LISN Voltage Division Factor (dB)+ Cable loss(dB)

Over Limit = Measurement – Limit

3.4 Radiated emission Test Data

9 kHz-30MHz:

Test Date:	2024-06-19	Test By:	Bard Huang
Environment condition:	Temperature: 22.8°C; Relative Humidity:67%; ATM Pressure: 100kPa		

For radiated emissions below 30MHz, there were no emissions found within 20dB of limit.

30MHz-1GHz:

Test Date:	2024-06-19	Test By:	Bard Huang
Environment condition:	Temperature: 22.8°C; Relative Humidity:67%; ATM Pressure: 100kPa		

Model: H7057

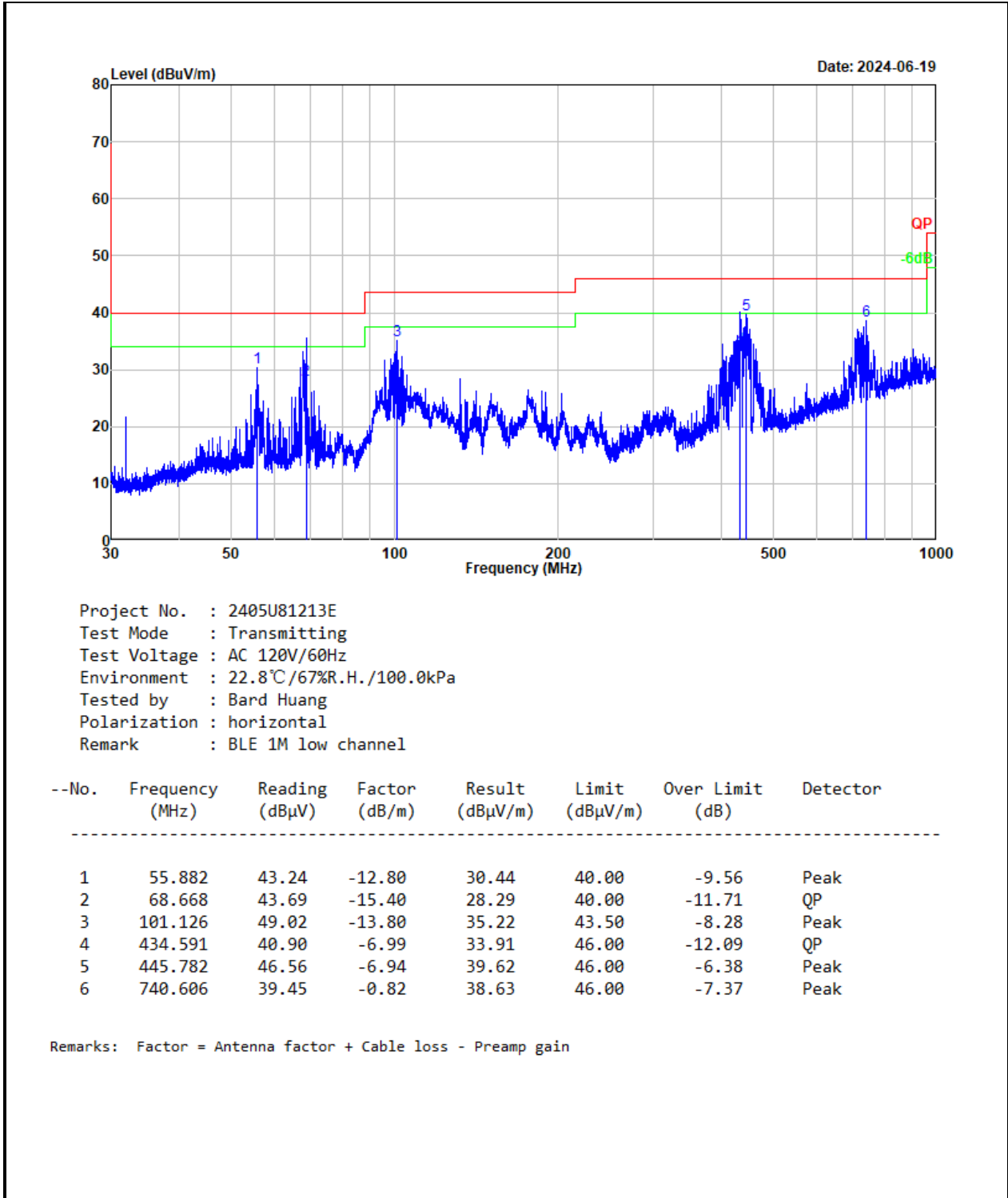

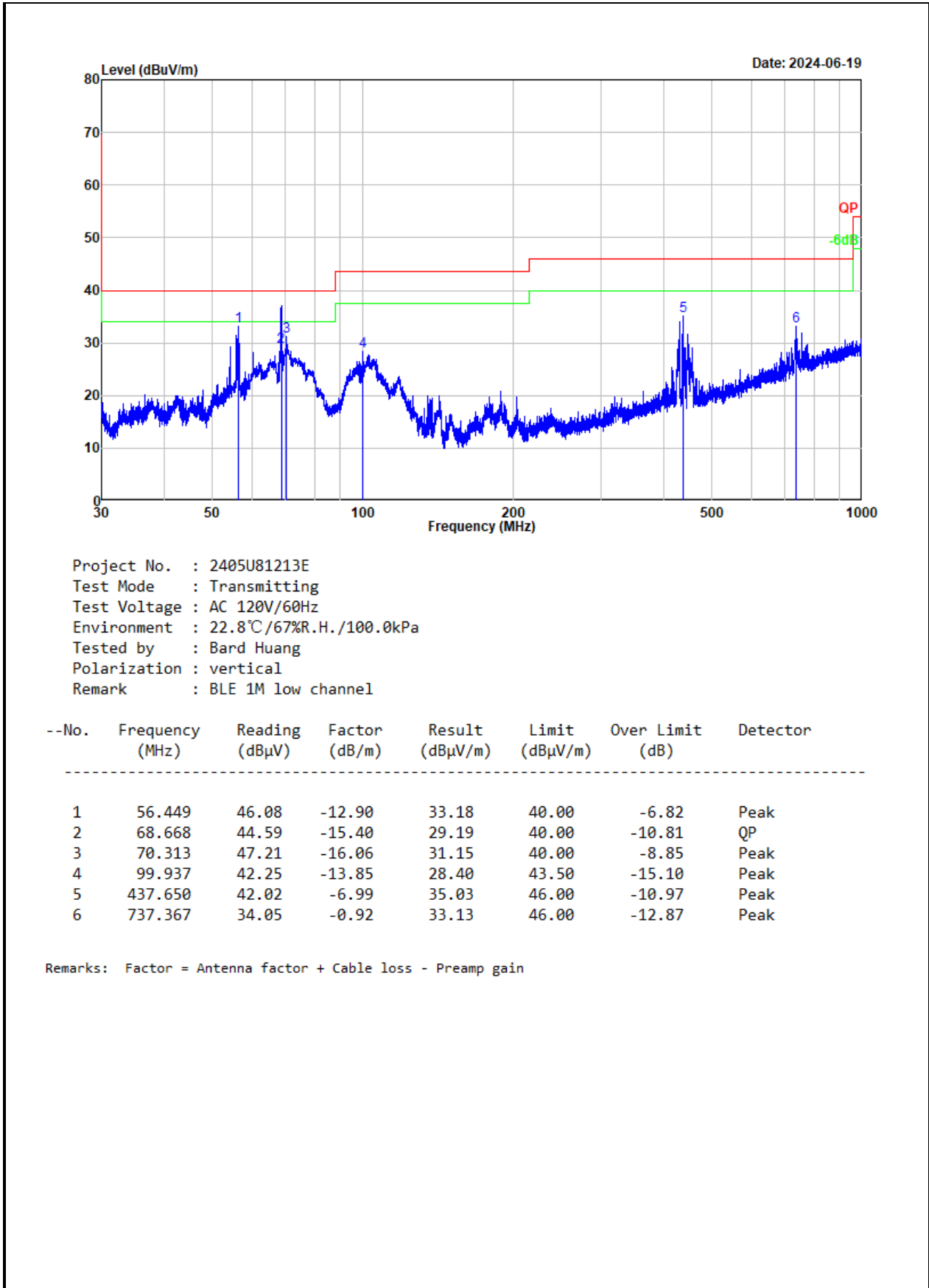

Model: H7058

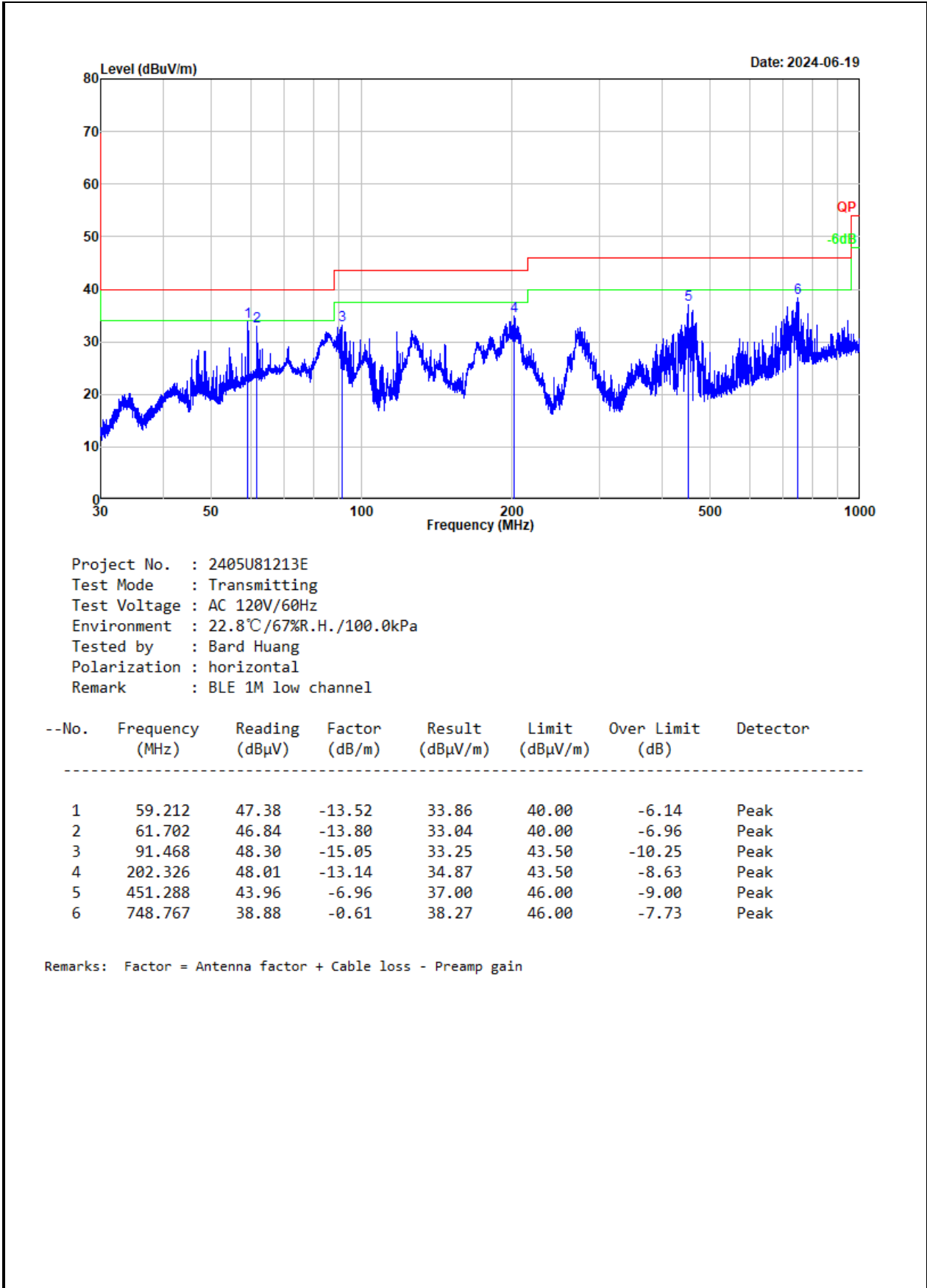

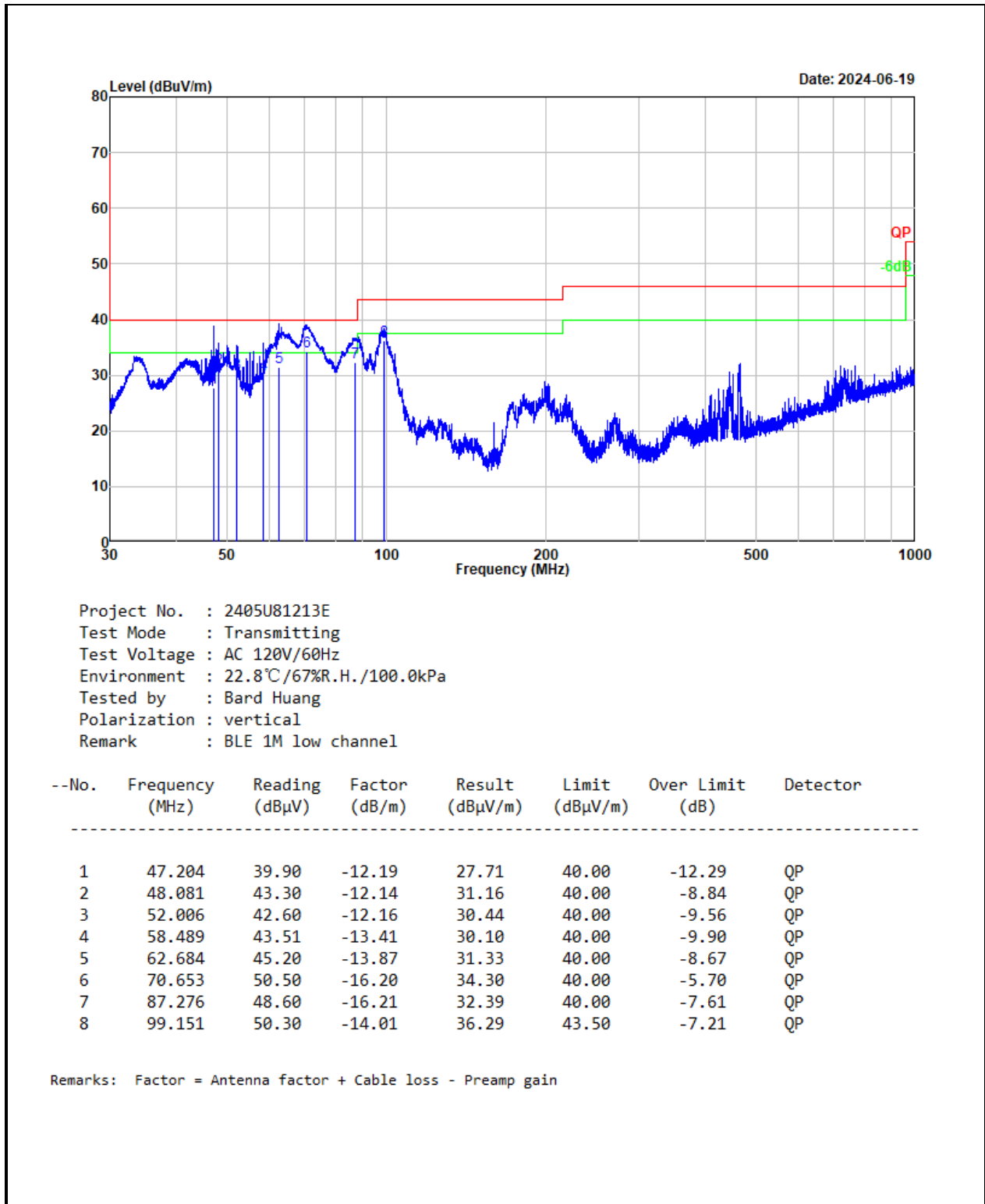

Remark:

Result = Reading + Factor

Factor = Antenna factor + Cable loss – Amplifier gain

Over Limit = Result – Limit

Above 1GHz:

Test Date:	2024-06-27	Test By:	Luke Li
Environment condition:	Temperature: 22.5°C; Relative Humidity:67%; ATM Pressure: 100.5kPa		

Frequency (MHz)	Reading level (dBμV)	Polar	Corrected Factor (dB/m)	Corrected Amplitude (dBμV/m)	Limit (dBμV/m)	Margin (dB)	Remark
BLE 1M							
Low Channel							
2390.000	38.14	horizontal	7.18	45.32	54.00	-8.68	Average
2390.000	49.04	horizontal	7.18	56.22	74.00	-17.78	Peak
2390.000	37.95	vertical	7.18	45.13	54.00	-8.87	Average
2390.000	48.74	vertical	7.18	55.92	74.00	-18.08	Peak
4804.000	48.90	horizontal	-0.21	48.69	74.00	-25.31	Peak
4804.000	48.32	vertical	-0.21	48.11	74.00	-25.89	Peak
Middle Channel							
4880.000	47.67	horizontal	0.08	47.75	74.00	-26.25	Peak
4880.000	47.66	vertical	0.08	47.74	74.00	-26.26	Peak
High Channel							
2483.500	43.96	horizontal	7.25	51.21	54.00	-2.79	Average
2483.500	55.87	horizontal	7.25	63.12	74.00	-10.88	Peak
2483.500	40.47	vertical	7.25	47.72	54.00	-6.28	Average
2483.500	51.01	vertical	7.25	58.26	74.00	-15.74	Peak
4960.000	47.82	horizontal	0.28	48.10	74.00	-25.90	Peak
4960.000	47.45	vertical	0.28	47.73	74.00	-26.27	Peak

Remark:

Corrected Amplitude= Reading level + corrected Factor

Corrected Factor = Antenna factor + Cable loss – Amplifier gain

Margin = Corrected Amplitude – Limit

For the test result of Peak below the Peak limit more than 20dB, which can compliance with the average limit, just the Peak level was recorded.

The emission levels of other frequencies that were lower than the limit 20dB, not show in test report.

For emissions in 18GHz-25GHz range, all emissions were investigated and in the noise floor level.

Test plot for example as below:

Mode:	BLE 1M	Channel:	2402MHz
--------------	--------	-----------------	---------

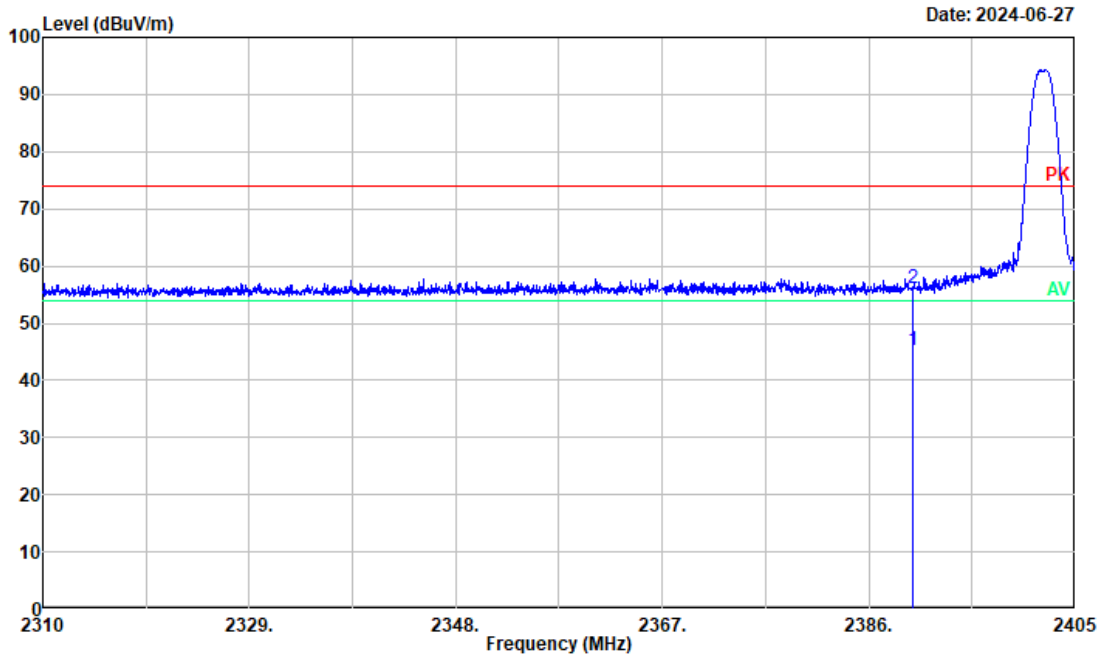

Project No. : 2405U81213E
 Test Mode : Transmitting
 Test Voltage : AC 120V/60Hz
 Environment : 22.5°C/67%R.H./100.5kPa
 Tested by : Luke Li
 Polarization : horizontal
 Remark : BLE 1M low channel

--No.	Frequency (MHz)	Reading (dBμV)	Factor (dB/m)	Result (dBμV/m)	Limit (dBμV/m)	Over Limit (dB)	Detector
1	2390.000	38.14	7.18	45.32	54.00	-8.68	Average
2	2390.000	49.04	7.18	56.22	74.00	-17.78	Peak

Remarks: Factor = Antenna factor + Cable loss - Preamp gain
 Result = Reading + Factor
 Over Limit = Result - Limit

Mode:	BLE 1M	Channel:	2402MHz
--------------	--------	-----------------	---------

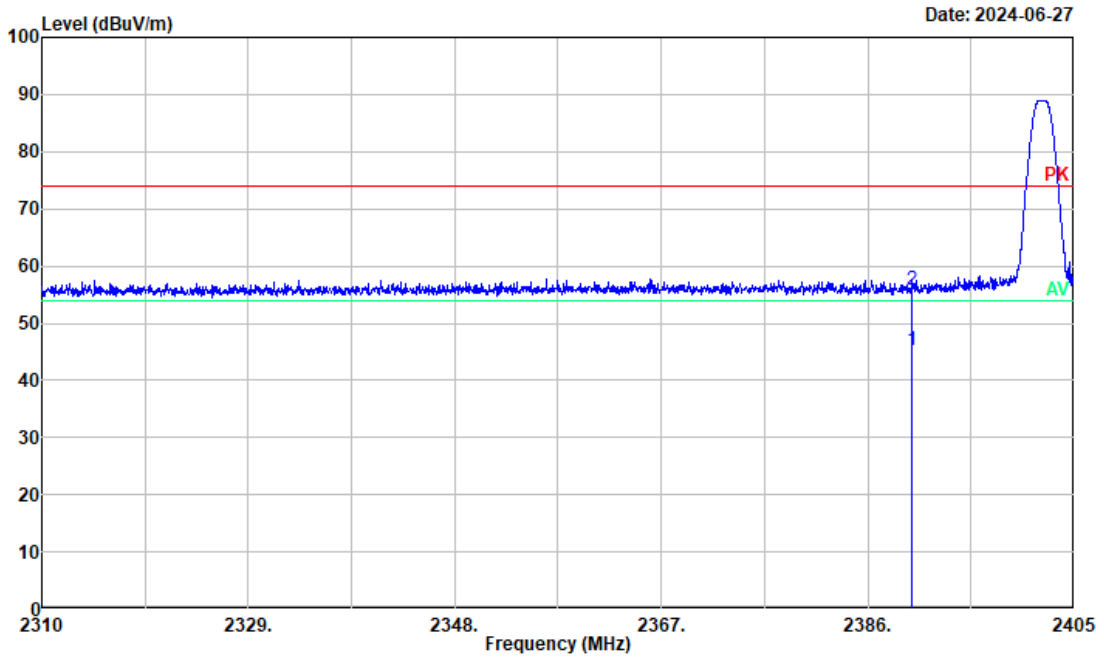

Project No. : 2405U81213E
 Test Mode : Transmitting
 Test Voltage : AC 120V/60Hz
 Environment : 22.5°C/67%R.H./100.5kPa
 Tested by : Luke Li
 Polarization : vertical
 Remark : BLE 1M low channel

--No.	Frequency (MHz)	Reading (dBμV)	Factor (dB/m)	Result (dBμV/m)	Limit (dBμV/m)	Over Limit (dB)	Detector
1	2390.000	37.95	7.18	45.13	54.00	-8.87	Average
2	2390.000	48.74	7.18	55.92	74.00	-18.08	Peak

Remarks: Factor = Antenna factor + Cable loss - Preamp gain
 Result = Reading + Factor
 Over Limit = Result - Limit

Mode:	BLE 1M	Channel:	2480MHz
--------------	--------	-----------------	---------

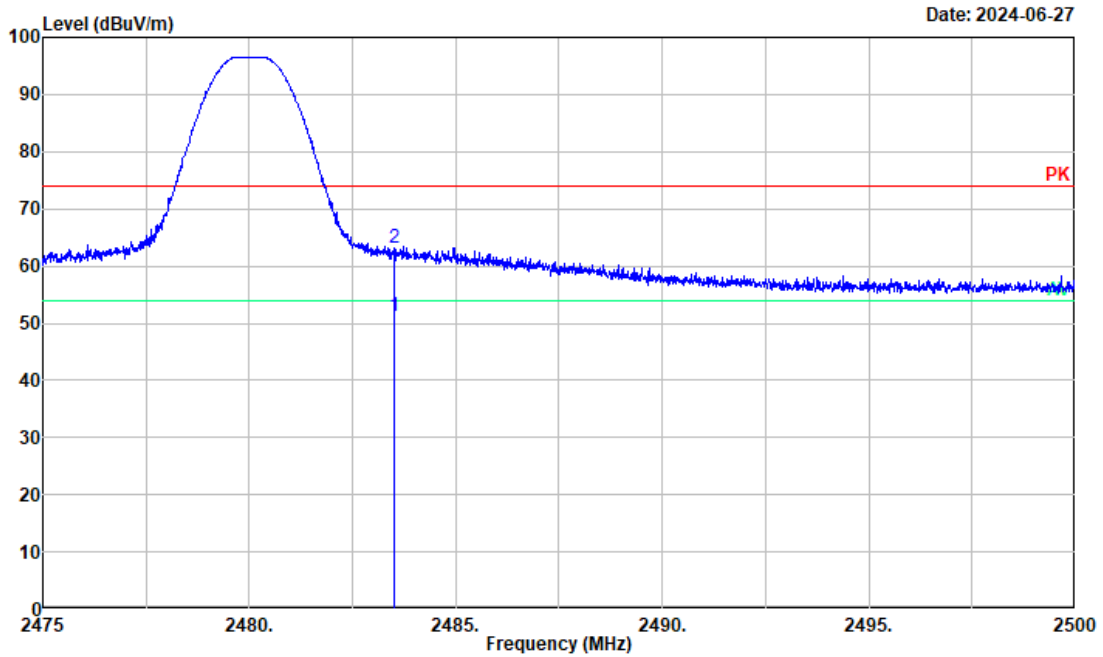

Project No. : 2405U81213E
 Test Mode : Transmitting
 Test Voltage : AC 120V/60Hz
 Environment : 22.5°C/67%R.H./100.5kPa
 Tested by : Luke Li
 Polarization : horizontal
 Remark : BLE 1M high channel

--No.	Frequency (MHz)	Reading (dBμV)	Factor (dB/m)	Result (dBμV/m)	Limit (dBμV/m)	Over Limit (dB)	Detector
1	2483.500	43.96	7.25	51.21	54.00	-2.79	Average
2	2483.500	55.87	7.25	63.12	74.00	-10.88	Peak

Remarks: Factor = Antenna factor + Cable loss - Preamp gain
 Result = Reading + Factor
 Over Limit = Result - Limit

Mode:	BLE 1M	Channel:	2480MHz
--------------	--------	-----------------	---------

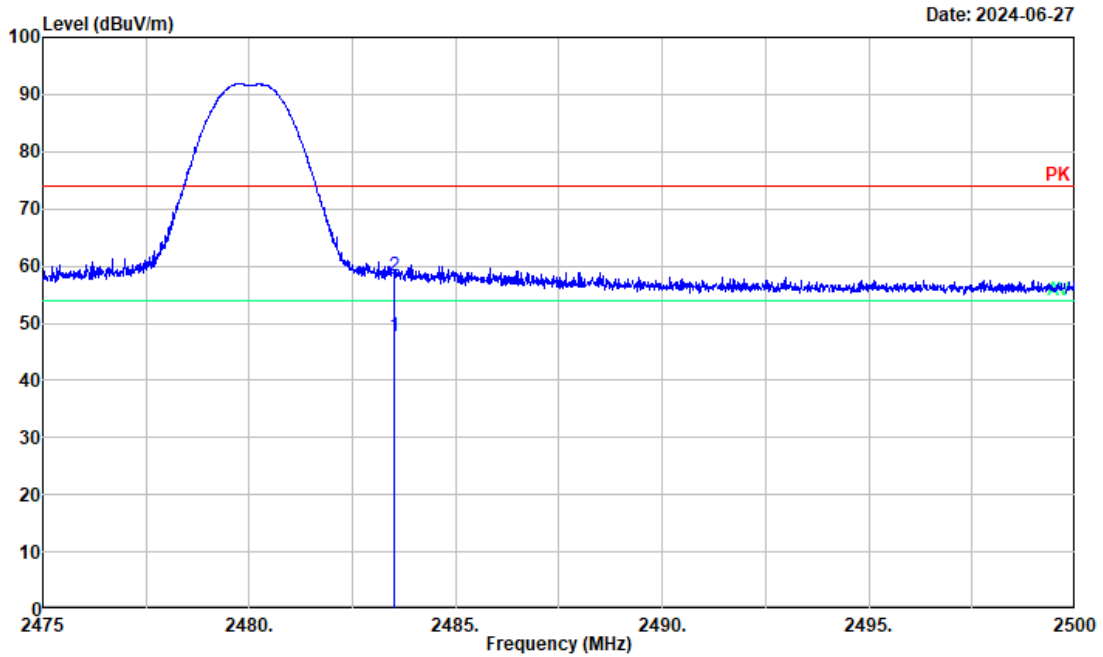

Project No. : 2405U81213E
 Test Mode : Transmitting
 Test Voltage : AC 120V/60Hz
 Environment : 22.5°C/67%R.H./100.5kPa
 Tested by : Luke Li
 Polarization : vertical
 Remark : BLE 1M high channel

--No.	Frequency (MHz)	Reading (dBμV)	Factor (dB/m)	Result (dBμV/m)	Limit (dBμV/m)	Over Limit (dB)	Detector
1	2483.500	40.47	7.25	47.72	54.00	-6.28	Average
2	2483.500	51.01	7.25	58.26	74.00	-15.74	Peak

Remarks: Factor = Antenna factor + Cable loss - Preamp gain
 Result = Reading + Factor
 Over Limit = Result - Limit

Mode:	BLE 1M	Channel:	2402MHz
--------------	--------	-----------------	---------

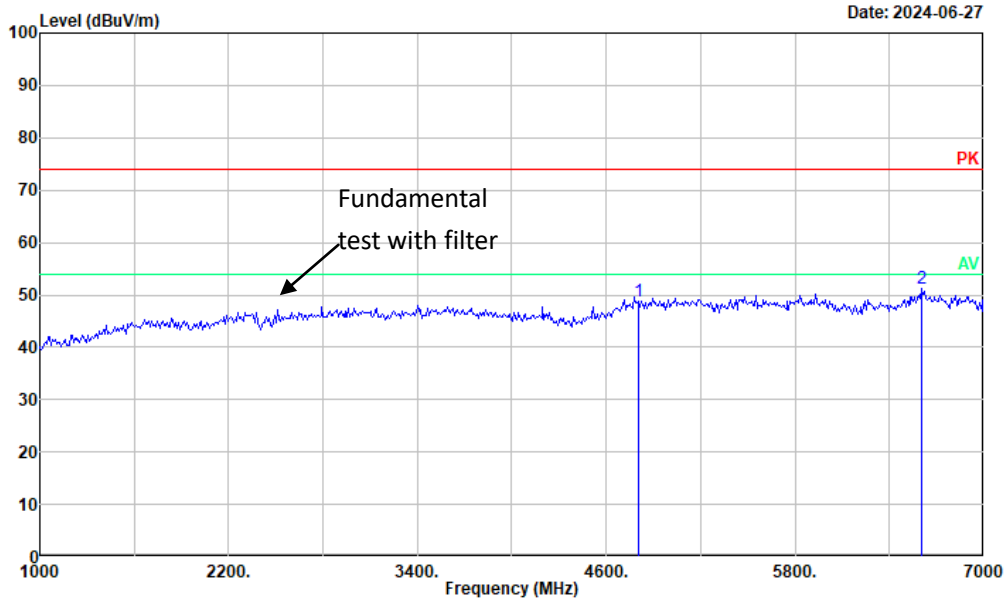

Project No. : 2405U81213E
 Test Mode : Transmitting
 Test Voltage : AC 120V/60Hz
 Environment : 22.5°C/67%R.H./100.5kPa
 Tested by : Luke Li
 Polarization : horizontal
 Remark : BLE 1M low channel

--No.	Frequency (MHz)	Reading (dBμV)	Factor (dB/m)	Result (dBμV/m)	Limit (dBμV/m)	Over Limit (dB)	Detector
1	4804.000	48.90	-0.21	48.69	74.00	-25.31	Peak
2	6604.302	48.89	2.33	51.22	74.00	-22.78	Peak

Remarks: Factor = Antenna factor + Cable loss - Preamp gain
 Result = Reading + Factor
 Over Limit = Result - Limit

Mode:	BLE 1M	Channel:	2402MHz
--------------	--------	-----------------	---------

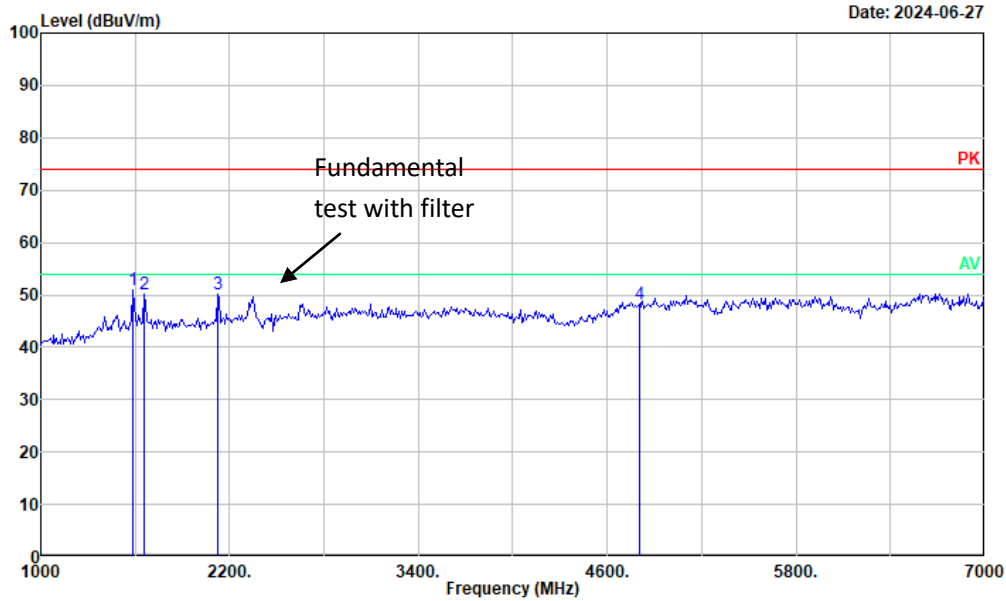

Project No. : 2405U81213E
 Test Mode : Transmitting
 Test Voltage : AC 120V/60Hz
 Environment : 22.5°C/67%R.H./100.5kPa
 Tested by : Luke Li
 Polarization : vertical
 Remark : BLE 1M low channel

--No.	Frequency (MHz)	Reading (dBμV)	Factor (dB/m)	Result (dBμV/m)	Limit (dBμV/m)	Over Limit (dB)	Detector
1	1586.793	54.70	-3.79	50.91	74.00	-23.09	Peak
2	1654.827	53.55	-3.29	50.26	74.00	-23.74	Peak
3	2122.561	53.65	-3.59	50.06	74.00	-23.94	Peak
4	4804.000	48.32	-0.21	48.11	74.00	-25.89	Peak

Remarks: Factor = Antenna factor + Cable loss - Preamp gain
 Result = Reading + Factor
 Over Limit = Result - Limit

Mode:	BLE 1M	Channel:	2402MHz
--------------	--------	-----------------	---------

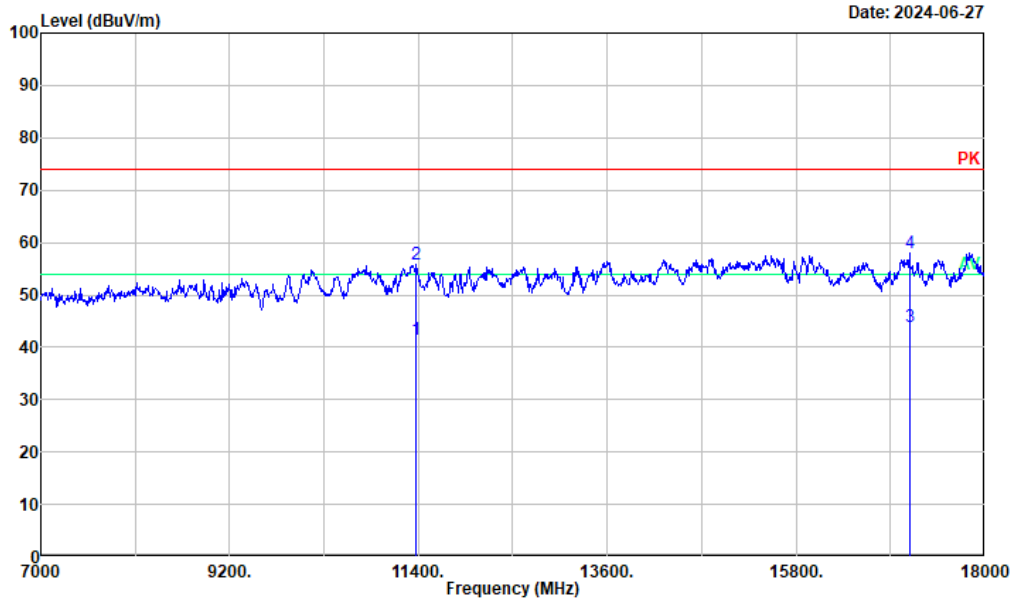

Project No. : 2405U81213E
 Test Mode : Transmitting
 Test Voltage : AC 120V/60Hz
 Environment : 22.5°C/67%R.H./100.5kPa
 Tested by : Luke Li
 Polarization : horizontal
 Remark : BLE 1M low channel

--No.	Frequency (MHz)	Reading (dBμV)	Factor (dB/m)	Result (dBμV/m)	Limit (dBμV/m)	Over Limit (dB)	Detector
1	11375.190	35.29	6.20	41.49	54.00	-12.51	Average
2	11375.190	49.62	6.20	55.82	74.00	-18.18	Peak
3	17124.060	36.41	7.53	43.94	54.00	-10.06	Average
4	17124.060	50.53	7.53	58.06	74.00	-15.94	Peak

Remarks: Factor = Antenna factor + Cable loss - Preamp gain
 Result = Reading + Factor
 Over Limit = Result - Limit

Mode:	BLE 1M	Channel:	2402MHz
--------------	--------	-----------------	---------

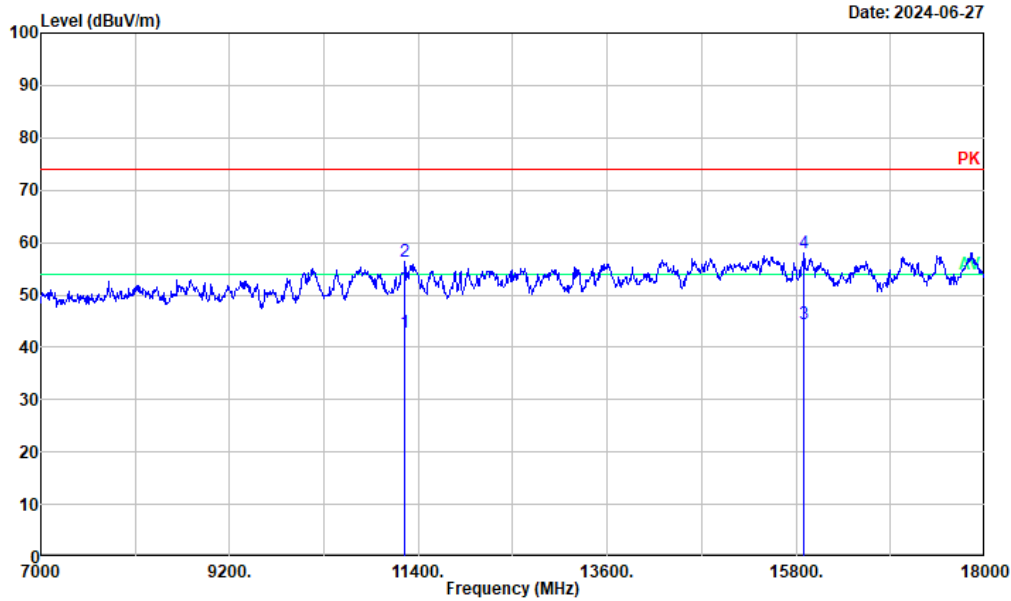

Project No. : 2405U81213E
 Test Mode : Transmitting
 Test Voltage : AC 120V/60Hz
 Environment : 22.5°C/67%R.H./100.5kPa
 Tested by : Luke Li
 Polarization : vertical
 Remark : BLE 1M low channel

--No.	Frequency (MHz)	Reading (dBμV)	Factor (dB/m)	Result (dBμV/m)	Limit (dBμV/m)	Over Limit (dB)	Detector
1	11239.120	35.81	6.91	42.72	54.00	-11.28	Average
2	11239.120	49.38	6.91	56.29	74.00	-17.71	Peak
3	15890.950	36.13	8.27	44.40	54.00	-9.60	Average
4	15890.950	49.82	8.27	58.09	74.00	-15.91	Peak

Remarks: Factor = Antenna factor + Cable loss - Preamp gain
 Result = Reading + Factor
 Over Limit = Result - Limit

Mode:	BLE 1M	Channel:	2402MHz
--------------	--------	-----------------	---------

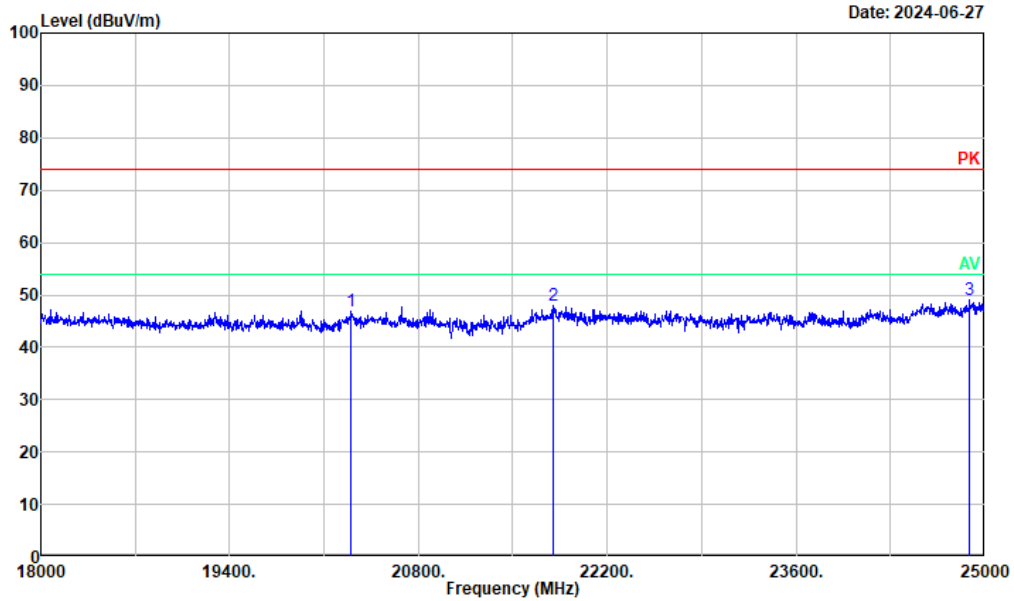

Project No. : 2405U81213E
 Test Mode : Transmitting
 Test Voltage : AC 120V/60Hz
 Environment : 22.5°C/67%R.H./100.5kPa
 Tested by : Luke Li
 Polarization : horizontal
 Remark : BLE 1M low channel

--No.	Frequency (MHz)	Reading (dBμV)	Factor (dB/m)	Result (dBμV/m)	Limit (dBμV/m)	Over Limit (dB)	Detector
1	20300.650	54.34	-7.39	46.95	74.00	-27.05	Peak
2	21802.900	54.88	-6.98	47.90	74.00	-26.10	Peak
3	24884.440	52.55	-3.58	48.97	74.00	-25.03	Peak

Remarks: Factor = Antenna factor + Cable loss - Preamp gain
 Result = Reading + Factor
 Over Limit = Result - Limit

Mode:	BLE 1M	Channel:	2402MHz
--------------	--------	-----------------	---------

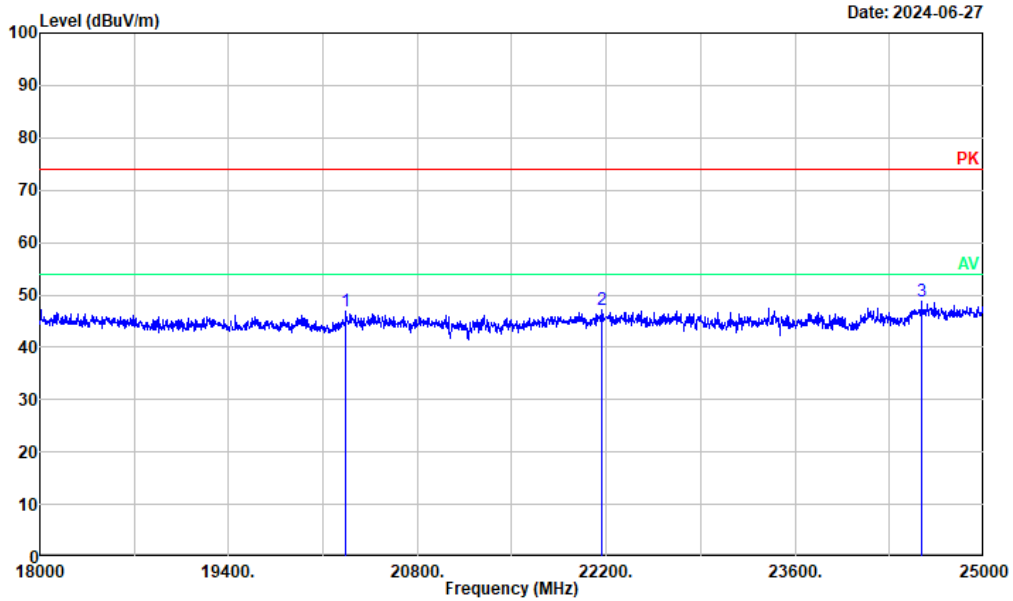

Project No. : 2405U81213E
 Test Mode : Transmitting
 Test Voltage : AC 120V/60Hz
 Environment : 22.5°C/67%R.H./100.5kPa
 Tested by : Luke Li
 Polarization : vertical
 Remark : BLE 1M low channel

--No.	Frequency (MHz)	Reading (dBμV)	Factor (dB/m)	Result (dBμV/m)	Limit (dBμV/m)	Over Limit (dB)	Detector
1	20265.630	54.25	-7.35	46.90	74.00	-27.10	Peak
2	22170.590	54.10	-6.87	47.23	74.00	-26.77	Peak
3	24537.770	54.42	-5.55	48.87	74.00	-25.13	Peak

Remarks: Factor = Antenna factor + Cable loss - Preamp gain
 Result = Reading + Factor
 Over Limit = Result - Limit

3.5 RF Conducted Test Data

Test Date:	2024-06-29~2024-09-10	Test By:	Ryan Zhang
Environment condition:	Temperature: 25.2~25.4°C; Relative Humidity:49~50%; ATM Pressure: 100.3~100.6kPa		

3.5.1 6 dB Emission Bandwidth and 99% Occupied Bandwidth

Test Mode	Channel	6dB BW [MHz]	99% OBW[MHz]	6dB BW Limit[MHz]	Verdict
BLE 1M	2402	0.668	1.072	0.5	pass
	2440	0.680	1.084	0.5	pass
	2480	0.680	1.080	0.5	pass

3.5.2 Maximum Conducted Peak Output Power

Test Mode	Channel [MHz]	Result [dBm]	Limit [dBm]	Verdict
BLE 1M	2402	-6.20	30	Pass
	2440	-6.35	30	Pass
	2480	-6.43	30	Pass

3.5.3 Power Spectral Density

Test Mode	Channel [MHz]	Result [dBm/3kHz]	Limit [dBm/3kHz]	Verdict
BLE 1M	2402	-19.93	8	Pass
	2440	-20.07	8	Pass
	2480	-20.16	8	Pass

3.5.4 100 kHz Bandwidth of Frequency Band Edge

Test Mode	Channel	Result	Limit	Verdict
BLE 1M	2402	Refer test plot	Refer test plot	Pass
	2480	Refer test plot	Refer test plot	Pass

3.5.5 Duty Cycle

Test Mode	Channel	Ton (ms)	Ton+off (ms)	Duty Cycle [%]	1/T	VBW setting [Hz]
BLE 1M	2440	100	100	100	/	10

Test Plots:

6 dB Emission Bandwidth:

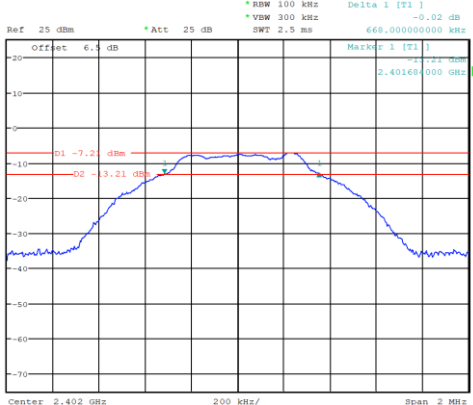
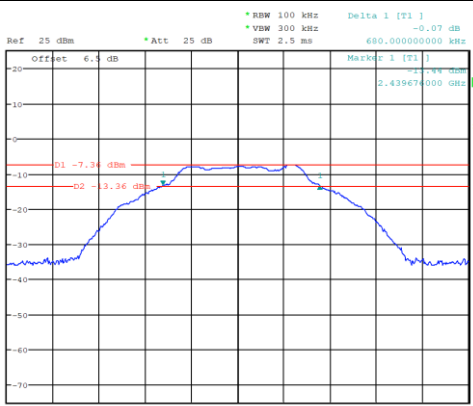
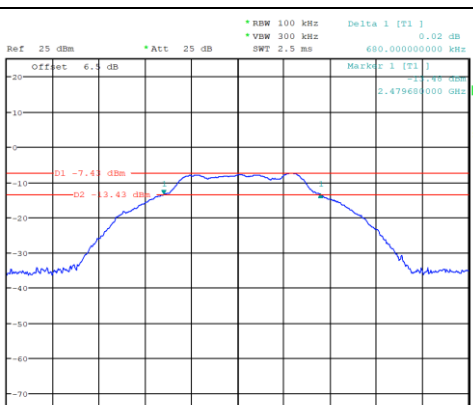
BLE 1M	/
Lowest channel	/
 <p>Date: 29 JUN 2024 14:22:59 Project No.: 2405U81213E Tester: Ryan Zhang</p>	/
Middle channel	/
 <p>Date: 29 JUN 2024 14:24:25 Project No.: 2405U81213E Tester: Ryan Zhang</p>	/
High channel	/
 <p>Date: 29 JUN 2024 14:25:31 Project No.: 2405U81213E Tester: Ryan Zhang</p>	/

99% Occupied Bandwidth:

BLE 1M	/
Lowest channel	/
<p>Date: 10.SEP.2024 16:14:53 Project No.:2405081213E Tester:Ryan Zhang</p>	/
Middle channel	/
<p>Date: 10.SEP.2024 16:15:31 Project No.:2405081213E Tester:Ryan Zhang</p>	/
High channel	/
<p>Date: 10.SEP.2024 16:16:03 Project No.:2405081213E Tester:Ryan Zhang</p>	/

Maximum Conducted Peak Output Power:

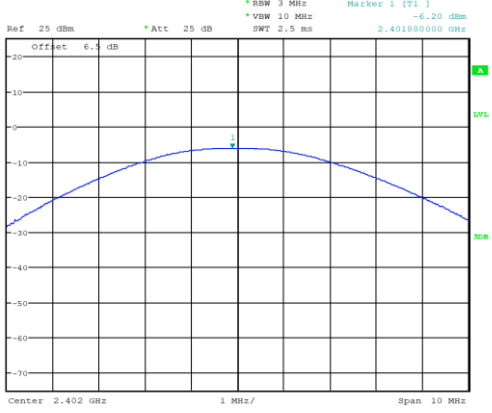
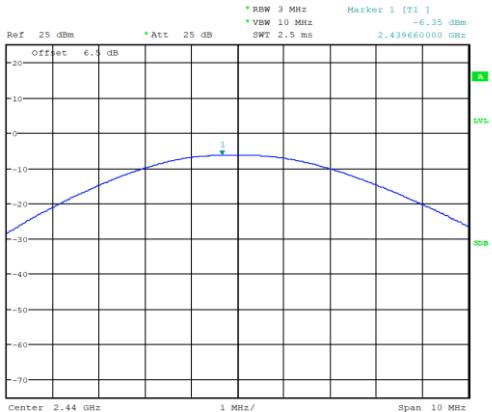
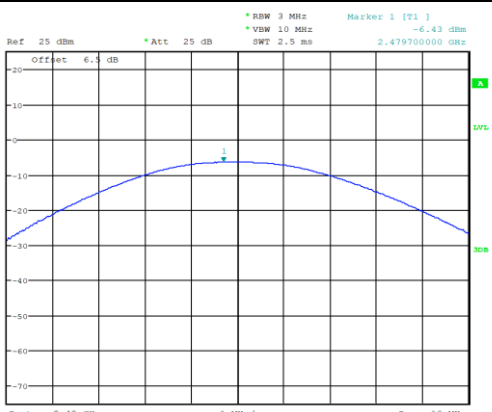
BLE 1M	/
Lowest channel	/
 <p>Ref: 25 dBm *Att: 25 dB *RBW 3 MHz Marker 1 [T1] -6.20 dBm *VBW 10 MHz SWT 2.5 ms 2.40200000 GHz</p> <p>Offset: 6.4 dB</p> <p>Center: 2.402 GHz 1 MHz/ Span: 10 MHz</p> <p>Date: 29.JUN.2024 14:23:22 Project No.: 2405U81213E Tester: Ryan Zhang</p>	/
Middle channel	/
 <p>Ref: 25 dBm *Att: 25 dB *RBW 3 MHz Marker 1 [T1] -6.35 dBm *VBW 10 MHz SWT 2.5 ms 2.43960000 GHz</p> <p>Offset: 6.4 dB</p> <p>Center: 2.44 GHz 1 MHz/ Span: 10 MHz</p> <p>Date: 29.JUN.2024 14:24:45 Project No.: 2405U81213E Tester: Ryan Zhang</p>	/
High channel	/
 <p>Ref: 25 dBm *Att: 25 dB *RBW 3 MHz Marker 1 [T1] -6.43 dBm *VBW 10 MHz SWT 2.5 ms 2.47970000 GHz</p> <p>Offset: 6.4 dB</p> <p>Center: 2.48 GHz 1 MHz/ Span: 10 MHz</p> <p>Date: 29.JUN.2024 14:25:52 Project No.: 2405U81213E Tester: Ryan Zhang</p>	/

Power Spectral Density:

BLE 1M	/
Lowest channel	/
<p>Date: 29.JUN.2024 14:23:29 Project No.:2405081213E Tester:Ryan Zhang</p>	/
Middle channel	/
<p>Date: 29.JUN.2024 14:24:52 Project No.:2405081213E Tester:Ryan Zhang</p>	/
High channel	/
<p>Date: 29.JUN.2024 14:25:58 Project No.:2405081213E Tester:Ryan Zhang</p>	/

100kHz Bandwidth of Frequency Band Edge:

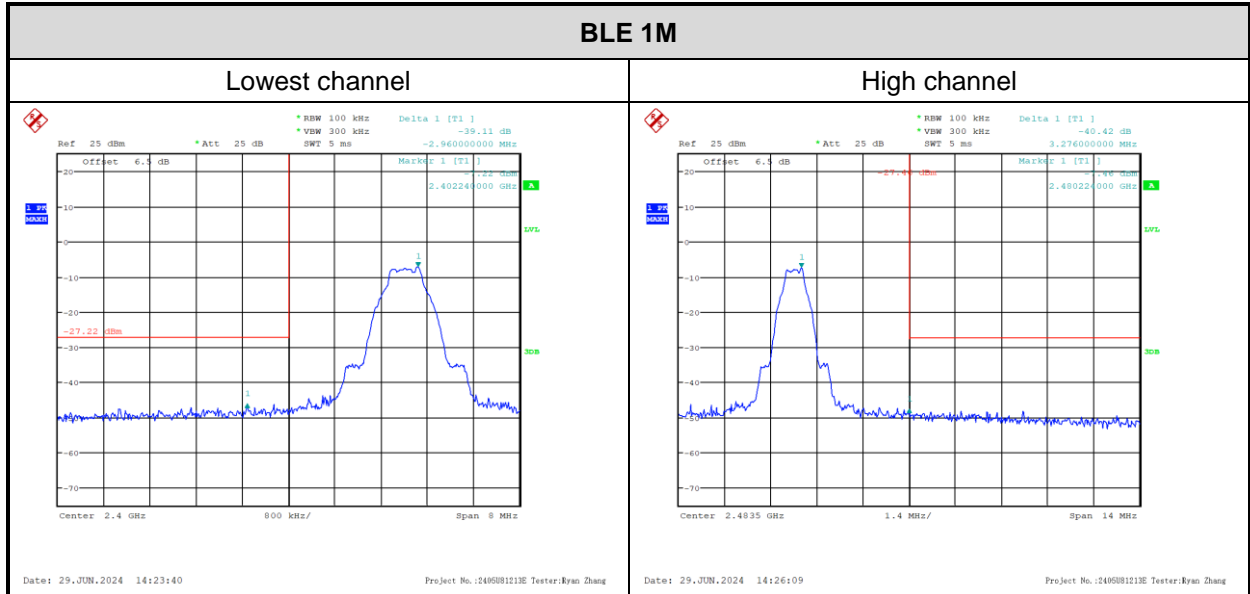

Duty cycle:

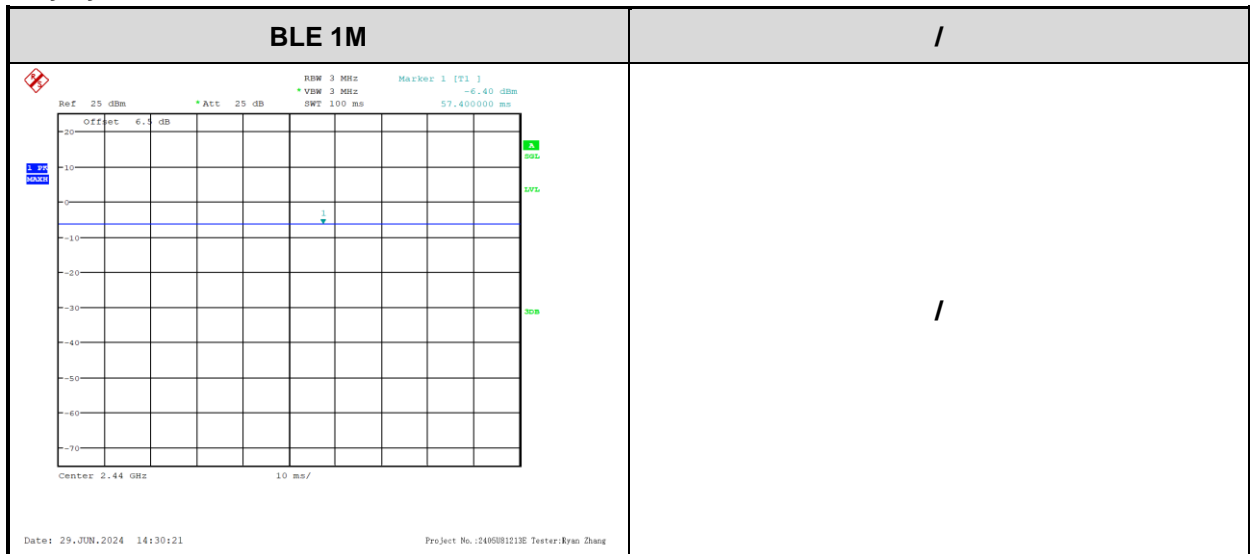

4 Test Setup Photo

Please refer to the attachment 2405U81213E Test Setup photo.

5 E.U.T Photo

Please refer to the attachment 2405U81213E External photo and 2405U81213E Internal photo.

---End of Report---