

TRUST ELECTRONICS LTD

DESC	ϕ 20.5x43-6.3uh-15mm-C	Rev: A.0	CUST:	8TECH
			P/N:	FITX205X43-6R3-15
			CUST P/N:	

A	43±1
B	20.5±0.5
C	1.74-2.1
D	15 ± 2.0
E	2-4
F	50±0.5
G	2.0 Max
H	2.79-3.4
I	8±1

DIMENSION:(mm)

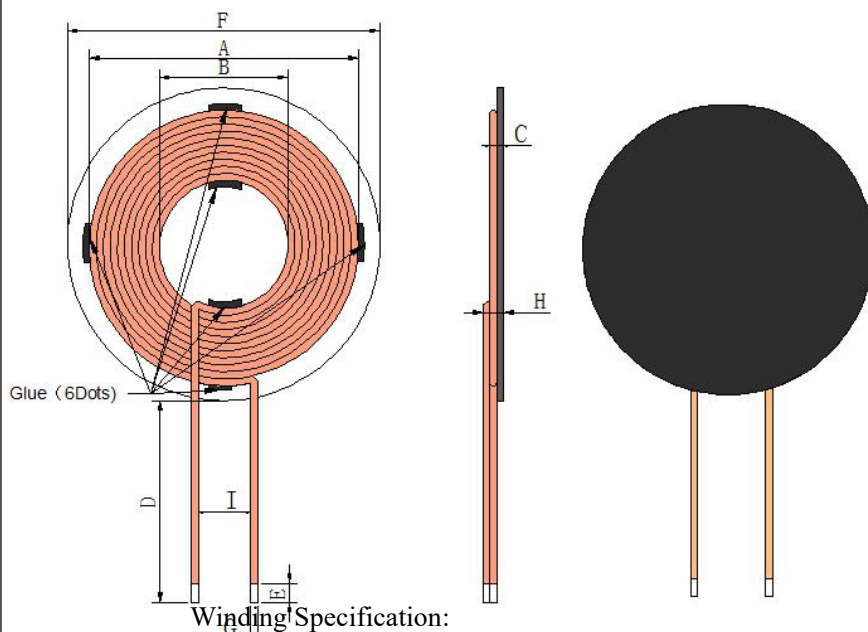

1. The coil crosses out
2. Magnetic sheet size ϕ 50*0.65mm, Two-sided black film of magnetic film, Black film size is ϕ 49*0.05mm.
3. The coil glue is fixed to the sheet.



PREPARED BY/DATE	CHECKED BY/DATE
Ou Liangqing 2021/07/21	Wu Qiaokang 2021/07/21