



FCC CERTIFICATION TEST REPORT

Applicant:	Guangzhou Lihuan Information Technology Co., Ltd.
Address:	Room 401, No.192 kezhu Road, Huangpu District, Guangzhou, China
Manufacturer:	Guangdong Coagent Electronic Technology Co., Ltd.
Address:	Foshan City, Southwest Industrial Park, Sanshui District, Guangdong Haobangshou Electronic Technology Co., Ltd
Product Description:	Car Audio Navigation
Brand Name:	NA
Tested Model:	M903AT-11T, M903AT-10T
FCC ID:	2A7U2-M903AT-11T
Report No.:	JCF221018002-001
Received Date:	Oct. 18, 2022
Tested Date:	Oct. 18, 2022 ~ Dec. 22, 2022
Issued Date:	Dec. 22, 2022
Test Standards:	FCC Rules and Regulations Part 15 Subpart C,
Test Procedure :	ANSI C63.10: 2013
Test Result:	Pass
Prepared By:	
 <u>Roger/Engineer</u>	
 Date: Dec. 22, 2022	
Reviewed By:	
 <u>Jone Lv/Engineer</u>	
Date: Dec. 22, 2022	
Approved By:	
 <u>Talent Zhang/Engineer</u>	
Date: Dec. 22, 2022	

Note: The test results in this report apply exclusively to the tested model / sample. Without written approval of Guangzhou Jingce Testing Technology Co., Ltd. the test report shall not be reproduced except in full.

Report Revise Record

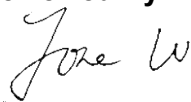
Report Version	Revise Time	Issued Date	Valid Version	Notes
V1.0	/	Dec. 22, 2022	Original Report	/

Table of Contents

1. Test Report Declare	5
2. Summary of Test Results	6
3. Test Laboratory	6
4. Equipment Under Test	7
4.1. Description of EUT	7
4.2. Channel List	7
4.3. Packet Type Configuration	8
4.4. Test Channel Configuration	8
4.5. Test environment conditions	8
4.6. The Worse Case Power Setting Parameter	8
4.7. Description of Available Antennas	9
5. Description of Test Setup	9
5.1. Accessory	9
5.2. Support Equipment	9
5.3. Test Setup	9
5.4. Setup Diagram for Tests	9
6. Measurement Uncertainty	10
7. Measuring Instrument and Software Used	10
8. On Time and Duty Cycle	12
8.1. Block diagram of test setup	12
8.2. Limits	12
8.3. Results	12
8.4. Original test data	13
9. 20 dB Occupied Bandwidth	16
9.1. Block diagram of test setup	16
9.2. Limit	16
9.3. Test Procedure	16
9.4. Results	16
9.5. Original test data	17
10. Conducted Output Power	20
10.1. Block diagram of test setup	20
10.2. Limits	20
10.3. Test Procedure	20
10.4. Results	20
10.5. Original test data	21
11. Carrier Hopping Channel Separation	24
11.1. Block diagram of test setup	24
11.2. Limits	24
11.3. Test Procedure	24
11.4. Results	24
11.5. Original test data	25
12. Number of Hopping Frequency	26
12.1. Block diagram of test setup	26
12.2. Limits	26
12.3. Test Procedure	26
12.4. Results	26
12.5. Original test data	27
13. Time of Occupancy (Dwell Time)	28
13.1. Block diagram of test setup	28

- 13.2. Limits 28
- 13.3. Test Procedure 28
- 13.4. Results 29
- 13.5. Original test data 30
- 14. Conducted Spurious Emission 33**
 - 14.1. Block diagram of test setup 33
 - 14.2. Limits 33
 - 14.3. Test Procedure 33
 - 14.4. Results 34
 - 14.5. Original test data 35
- 15. Radiated Emission 45**
 - 15.1. Block diagram of test setup 45
 - 15.2. Limit 46
 - 15.3. Test Procedure 48
 - 15.4. Results 51
 - 15.5. Original test data 51
- 16. AC Power Line Conducted Emissions 52**
 - 16.1. Block diagram of test setup 52
 - 16.2. Limits 52
 - 16.3. Test procedure 52
 - 16.4. Test result 53
- 17. Antenna Requirements 54**
 - 17.1. Limits 54
 - 17.2. Result 54
- APPENDIX A – Radiated Emission Below 1GHz Test Data 55**
- APPENDIX B – Radiated Emission Above 1GHz Test Data 59**

1. Test Report Declare

Applicant:	Guangzhou Lihuan Information Technology Co., Ltd.
Address:	Room 401, No.192 kezhu Road, Huangpu District, Guangzhou, China
Manufacturer:	Guangdong Coagent Electronic Technology Co., Ltd.
Address:	Foshan City, Southwest Industrial Park, Sanshui District, Guangdong Haobangshou Electronic Technology Co., Ltd
Product Name:	Car Audio Navigation
Brand Name:	NA
Model Name:	M903AT-11T, M903AT-10T
Difference Description:	There are two different product models in this report. They are only the heat sink is different and the installed direction is different . The antenna and RF related parts are the same.

Note: The model: M903AT-10T only test for Radiated Emission below 1GHz.

We Declare:

The equipment described above is tested by Guangzhou Jingce Testing Technology Co., Ltd. and in the configuration tested the equipment complied with the standards specified above. The test results are contained this test report and Guangzhou Jingce Testing Technology Co., Ltd. is assumed of full responsibility for the accuracy and completeness of these tests.

2. Summary of Test Results

Summary of Test Results			
Clause	Test Items	FCC/ISED Rules	Test Result
1	20 dB Bandwidth	FCC 15.247 (a) (1)	Pass
2	Conducted Output Power	FCC 15.247 (b) (1)	Pass
3	Carrier Hopping Channel Separation	FCC 15.247 (a) (1)	Pass
4	Number of Hopping Frequency	15.247 (a) (1) III	Pass
5	Time of Occupancy (Dwell Time)	15.247 (a) (1) III	Pass
6	Conducted Band edge	FCC 15.247 (d)	Pass
7	Radiated Band edge and Spurious	FCC 15.247 (d) FCC 15.209 FCC 15.205	Pass
8	Conducted Emission Test For AC Power Port	FCC 15.207	NA
9	Antenna Requirement	FCC 15.203	Pass

Note: The conducted emission tests at AC port are not required test.

3. Test Laboratory

Guangzhou Jingce Testing Technology Co., Ltd.

Add.: No.192, Kezhu Road, Huangpu District, Guangzhou, Guangdong, China

Association for Laboratory Accreditation(A2LA). Certificate Number: 6594.01

FCC Designation Number: CN1331. Test Firm Registration Number: 360543

IC Test Firm Registration Number: 28796

Conformity Assessment Body identifier: CN0138

4. Equipment Under Test

4.1. Description of EUT

EUT Name:	Car Audio Navigation
Model Number:	M903AT-11T, M903AT-10T
EUT Function Description:	Please reference user's manual
Power Supply:	DC 12V/10A
Hardware Version:	NA
Software Version:	NA
Radio Specification:	Bluetooth V4.2
Operation Frequency:	2402 MHz - 2480 MHz
Modulation:	GFSK, $\pi/4$ -DQPSK, 8DPSK
Data Rate:	1Mbps, 2Mbps, 3Mbps
Antenna Type:	PCB Antenna, -3.0 dBi

Note 1: EUT is the ab. of equipment under test.

Note 2: The antenna gain is declared by the customer and the laboratory is not responsible for the accuracy of the antenna gain.

4.2. Channel List

Channel	Frequency (MHz)	Channel	Frequency (MHz)	Channel	Frequency (MHz)	Channel	Frequency (MHz)
0	2402	20	2422	40	2442	60	2462
1	2403	21	2423	41	2443	61	2463
2	2404	22	2424	42	2444	62	2464
3	2405	23	2425	43	2445	63	2465
4	2406	24	2426	44	2446	64	2466
5	2407	25	2427	45	2447	65	2467
6	2408	26	2428	46	2448	66	2468
7	2409	27	2429	47	2449	67	2469
8	2410	28	2430	48	2450	68	2470
9	2411	29	2431	49	2451	69	2471
10	2412	30	2432	50	2452	70	2472
11	2413	31	2433	51	2453	71	2473
12	2414	32	2434	52	2454	72	2474
13	2415	33	2435	53	2455	73	2475
14	2416	34	2436	54	2456	74	2476
15	2417	35	2437	55	2457	75	2477
16	2418	36	2438	56	2458	76	2478
17	2419	37	2439	57	2459	77	2479
18	2420	38	2440	58	2460	78	2480
19	2421	39	2441	59	2461	/	/

4.3. Packet Type Configuration

Test Mode	Packet Type	Setting(Packet Length)
GFSK	DH1	27
	DH3	183
	DH5	339
$\pi/4$ -DQPSK	2-DH1	54
	2-DH3	367
	2-DH5	679
8DPSK	3-DH1	83
	3-DH3	552
	3-DH5	1021

4.4. Test Channel Configuration

Tested mode, channel, information		
Mode	Channel	Frequency (MHz)
GFSK hopping on Tx mode	CH0 to CH78	2402 to 2480
$\pi/4$ -DQPSK hopping on Tx mode	CH0 to CH78	2402 to 2480
8DPSK hopping on Tx mode	CH0 to CH78	2402 to 2480
GFSK hopping off Tx mode	LCH: CH0	2402
	MCH: CH39	2441
	HCH: CH78	2480
$\pi/4$ -DQPSK hopping off Tx mode	LCH: CH0	2402
	MCH: CH39	2441
	HCH: CH78	2480
8DPSK hopping off Tx mode	LCH: CH0	2402
	MCH: CH39	2441
	HCH: CH78	2480

4.5. Test environment conditions

During the measurement the environmental conditions were within the listed ranges:

Temperature range:	21-25 °C
Humidity range:	40-75%
Pressure range:	86-106 kPa

4.6. The Worse Case Power Setting Parameter

The Worse Case Power Setting Parameter under 2400 ~ 2483.5MHz Band				
Test Software		Engineer Mode		
Modulation Type	Transmit Antenna Number	Test Software Setting Value		
		CH 0	CH 39	CH 78
GFSK	1	Default	Default	Default
$\pi/4$ -DQPSK	1	Default	Default	Default
8DPSK	1	Default	Default	Default

4.7. Description of Available Antennas

Test Mode	Transmit and Receive Mode	Description
GFSK	<input checked="" type="checkbox"/> 1TX, 1RX	Antenna 1 can be used as transmitting/receiving antenna.
$\pi/4$ -DQPSK	<input checked="" type="checkbox"/> 1TX, 1RX	Antenna 1 can be used as transmitting/receiving antenna.
8DPSK	<input checked="" type="checkbox"/> 1TX, 1RX	Antenna 1 can be used as transmitting/receiving antenna.

5. Description of Test Setup

5.1. Accessory

Description of Accessories	Manufacturer	Model Number	Description	Remark
/	/	/	/	/

5.2. Support Equipment

Equipment	Brand Name	Model Name	P/N
PC	Lenovo	T480	/
Battery	BOSH	/	/

5.3. Test Setup

The EUT can work in engineering mode.

5.4. Setup Diagram for Tests



6. Measurement Uncertainty

Where relevant, the following measurement uncertainty levels have been estimated for tests performed on the apparatus:

Test Item	Uncertainty
AC Power Conduction emission	1.37 dB
All Radiated emissions	5.4dB
Conducted emissions	3.09 dB
Occupied Channel Bandwidth	1.1%
Conducted Output power	0.82dB
Power Spectral Density	0.82dB

Note: This uncertainty represents an expanded uncertainty expressed at approximately the 95 % confidence level using a coverage factor of k = 2.

7. Measuring Instrument and Software Used

TS Test System						
Used	Equipment	Manufacturer	Model No.	Serial No.	Last Cal.	Due. Date
<input checked="" type="checkbox"/>	Spectrum Analyzer	Keysight	N9030B	MY56320512	Jul. 25, 2022	Jul. 24, 2023
<input checked="" type="checkbox"/>	Vector Signal Generator	Keysight	N5182B	MY57300334	Nov. 24, 2022	Nov. 23, 2023
<input checked="" type="checkbox"/>	Signal Generator	Keysight	N5171B	MY57280639	Nov. 24, 2022	Nov. 23, 2023
<input checked="" type="checkbox"/>	DC POWER	Keysight	E342A	MY59020356	Jul. 25, 2022	Jul. 24, 2023
<input checked="" type="checkbox"/>	Incubator thermometer	GWS	EL-02JA	21107288	Oct. 31, 2022	Oct. 30, 2023
<input checked="" type="checkbox"/>	Control unit(Power sensor)	Tonscend	JS0806-2	/	Jul. 25, 2022	Jul. 24, 2023
Software						
Used	Description	Manufacturer	Name		Version	
<input checked="" type="checkbox"/>	Test software	TS+	JS1120-3		V3.2.11	
RSE Test System						
Used	Equipment	Manufacturer	Model No.	Serial No.	Last Cal.	Due. Date
<input checked="" type="checkbox"/>	EMI Receiver	R&S	ESW	101685	Jul. 24, 2022	Jul. 23, 2023
<input checked="" type="checkbox"/>	Bilog Antenna	Schwarzbeck	VULB 9163	01416	Feb. 22, 2022	Feb. 21, 2023
<input checked="" type="checkbox"/>	Horn Antenna 1	Schwarzbeck	BBHA 9120 D	02411	May.30,2022	May. 29, 2023
<input checked="" type="checkbox"/>	Horn Antenna 2	ETS	3116C	00217677	Sep. 19, 2022	Sep. 18, 2023
<input checked="" type="checkbox"/>	Signal Pre-Amplifier	Tonscend	TAP01018050	AP21C806122	Aug. 08, 2022	Aug. 07, 2023
<input checked="" type="checkbox"/>	Signal Pre-Amplifier	Tonscend	TAP9K3G32	AP20K806104	Aug. 08, 2022	Aug. 07, 2023
<input checked="" type="checkbox"/>	Signal Pre-Amplifier	ETS	3116C-PA	00217677	Sep. 02, 2022	Sep. 01, 2023
<input checked="" type="checkbox"/>	Wideband radio communication tester	R&S	CMW500	163478	Jul. 25, 2022	Jul. 24, 2023
<input checked="" type="checkbox"/>	3m Fully-anechoic Chamber	ETS	RFD-100	/	Apr. 24, 2021	Apr. 23, 2024

Software						
Used	Description	Manufacturer	Name		Version	
<input checked="" type="checkbox"/>	Test software	TS+	TS+		V3.0.0.4	
Conducted Emission Test For AC Power Port						
Used	Equipment	Manufacturer	Model No.	Serial No.	Last Cal.	Due. Date
<input checked="" type="checkbox"/>	LISN	R&S	ENV216	102154	Jul. 24, 2022	Jul. 23, 2023
<input checked="" type="checkbox"/>	EMI Receiver	R&S	ESR3	102509	Jul. 24, 2022	Jul. 23, 2023
Software						
Used	Description	Manufacturer	Name		Version	
<input checked="" type="checkbox"/>	Test software	EZ	EZ-EMC		EMEC-3A1	
Other Instrument						
Used	Equipment	Manufacturer	Model No.	Serial No.	Last Cal.	Due. Date
<input checked="" type="checkbox"/>	Temperature & Humidity	Temperature	HTC-1	/	Jul. 24, 2022	Jul. 23, 2023

8. On Time and Duty Cycle

8.1. Block diagram of test setup

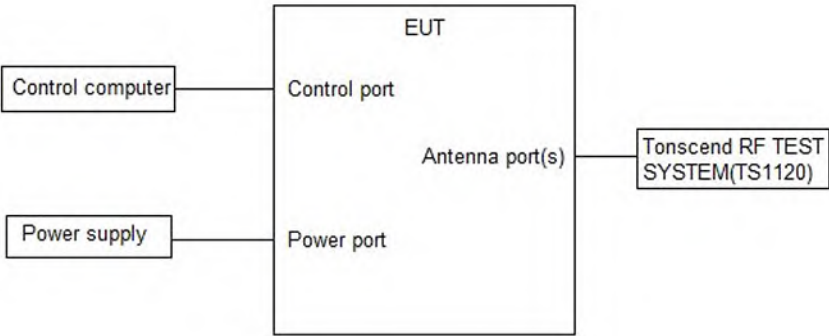

8.2. Limits

None; for reporting purposes only

8.3. Results

Test Mode	Ant.	Freq. (MHz)	ON Time (ms)	Period (ms)	Duty Cycle (%)	Duty Cycle Factor(dB)
DH5	Ant1	2402	2.89	3.75	77.07	1.13
		2441	2.89	3.75	77.07	1.13
		2480	2.89	3.75	77.07	1.13
2DH5	Ant1	2402	2.90	3.75	77.33	1.12
		2441	2.90	3.75	77.33	1.12
		2480	2.90	3.75	77.33	1.12
3DH5	Ant1	2402	2.90	3.75	77.33	1.12
		2441	2.90	3.75	77.33	1.12
		2480	2.90	3.75	77.33	1.12

Note: Duty Cycle Correction Factor=10log (1/x).

Where: x is Duty Cycle (Linear)

Where: T is On Time

If that calculated VBW is not available on the analyzer then the next higher value should be used.

8.4. Original test data







9. 20 dB Occupied Bandwidth

9.1. Block diagram of test setup

Same as section 8.1

9.2. Limit

CFR 47 FCC Part15 (15.247) Subpart C			
Section	Test Item	Limit	Frequency Range (MHz)
CFR 47 FCC 15.247 (a) (1)	20 dB Occupied Bandwidth	N/A	2400-2483.5

9.3. Test Procedure

Connect the UUT to the spectrum analyzer and use the following settings:

Center Frequency	The center frequency of the channel under test
Detector	Peak
RBW	For 20 dB Occupied Bandwidth: 1 % to 5 % of the 20 dB bandwidth
VBW	For 20 dB Occupied Bandwidth: approximately 3×RBW
Span	approximately 2 to 3 times the 20 dB bandwidth
Trace	Max hold
Sweep	Auto couple

Allow the trace to stabilize and measure the maximum width of the emission that is constrained by the frequencies associated with the two outermost amplitude points (upper and lower frequencies) that are attenuated by 20 dB and 99 % relative to the maximum level measured in the fundamental emission.

9.4. Results

20 dB Occupied Bandwidth:

Test Mode	Ant.	Freq. (MHz)	20db EBW (MHz)	FL (MHz)	FH (MHz)
DH5	Ant1	2402	0.954	2401.598	2402.552
		2441	0.951	2440.598	2441.549
		2480	0.951	2479.595	2480.546
2DH5	Ant1	2402	1.275	2401.433	2402.708
		2441	1.272	2440.433	2441.705
		2480	1.284	2479.433	2480.717
3DH5	Ant1	2402	1.296	2401.415	2402.711
		2441	1.272	2440.424	2441.696
		2480	1.284	2479.421	2480.705

9.5. Original test data

20 dB Occupied Bandwidth:





2DH5 Ant1 2441



2DH5 Ant1 2480

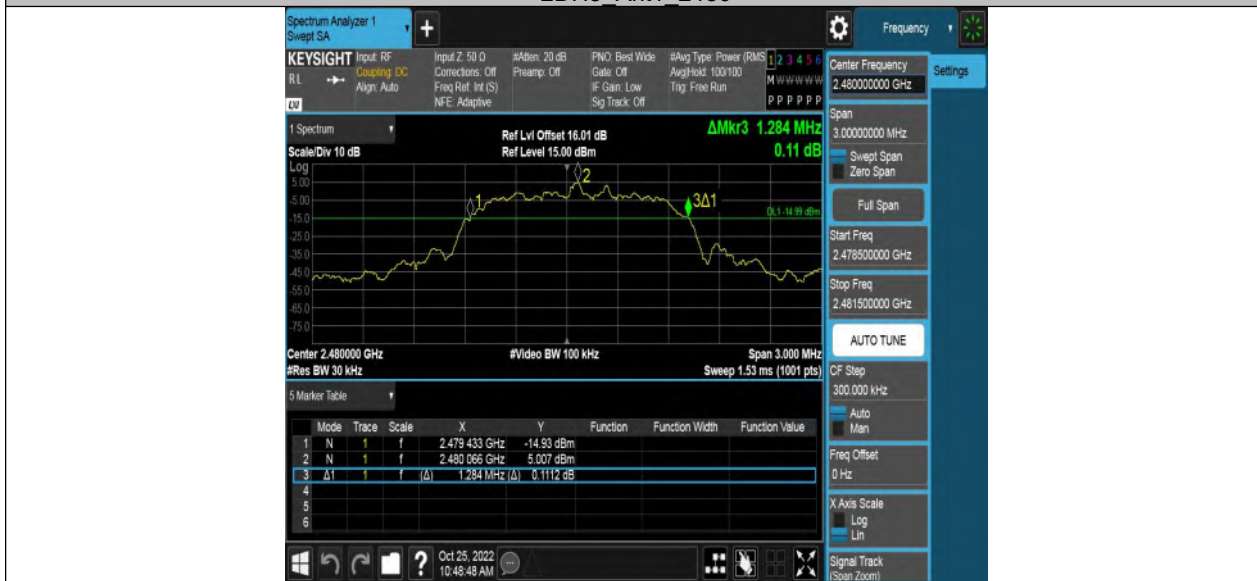

3DH5 Ant1 2402



10. Conducted Output Power

10.1. Block diagram of test setup

Same as section 8.1

10.2. Limits

CFR 47 FCC Part15 (15.247) , Subpart C			
Section	Test Item	Limit	Frequency Range (MHz)
CFR 47 FCC 15.247 (b) (1)	Peak Conducted Output Power	Hopping channel carrier frequencies separated by a minimum of 25 kHz or the 20 dB bandwidth of the hopping channel: 1 watt or 30dBm; Hopping channel carrier frequencies that are separated by 25 kHz or two-thirds of the 20 dB bandwidth of the hopping channel : 125 mW or 21dBm	2400-2483.5

10.3. Test Procedure

- (1) Connect EUT's antenna output to spectrum analyzer by RF cable.
- (2) Measure the maximum output power of EUT by spectrum analyzer with PK detector and RBW=3 MHz (above 20 dB bandwidth of measured signal), VBW=8 MHz

Note: The attenuator loss was inputted into spectrum analyzer as amplitude offset.

10.4. Results

Test Mode	Ant.	Freq. (MHz)	Conducted Peak Power (dBm)	Conducted Limit (dBm)	Verdict
DH5	Ant1	2402	6.56	≤20.97	PASS
		2441	7.25	≤20.97	PASS
		2480	7.79	≤20.97	PASS
2DH5	Ant1	2402	7.78	≤20.97	PASS
		2441	8.49	≤20.97	PASS
		2480	8.99	≤20.97	PASS
3DH5	Ant1	2402	8.18	≤20.97	PASS
		2441	8.87	≤20.97	PASS
		2480	9.36	≤20.97	PASS

10.5. Original test data

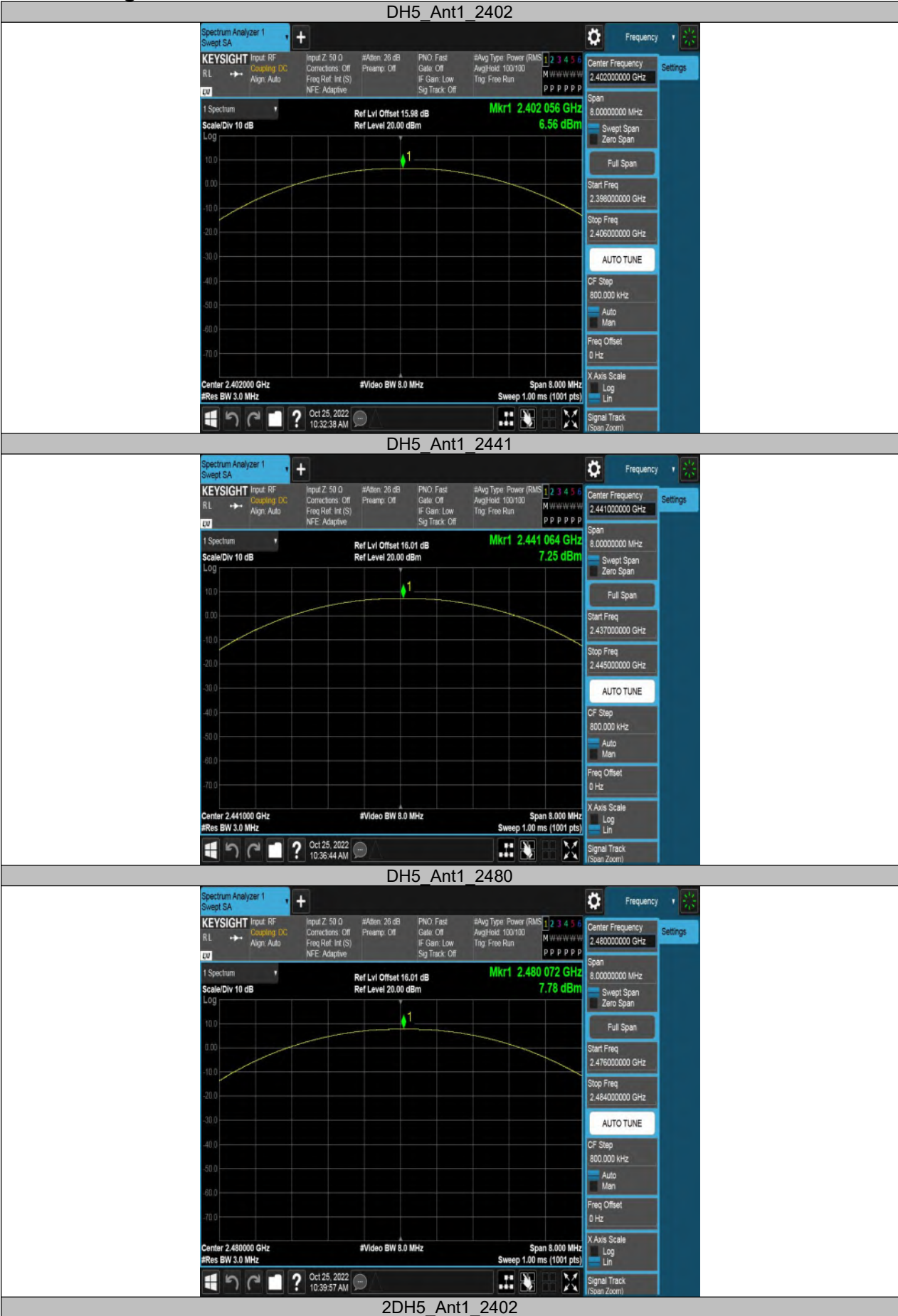

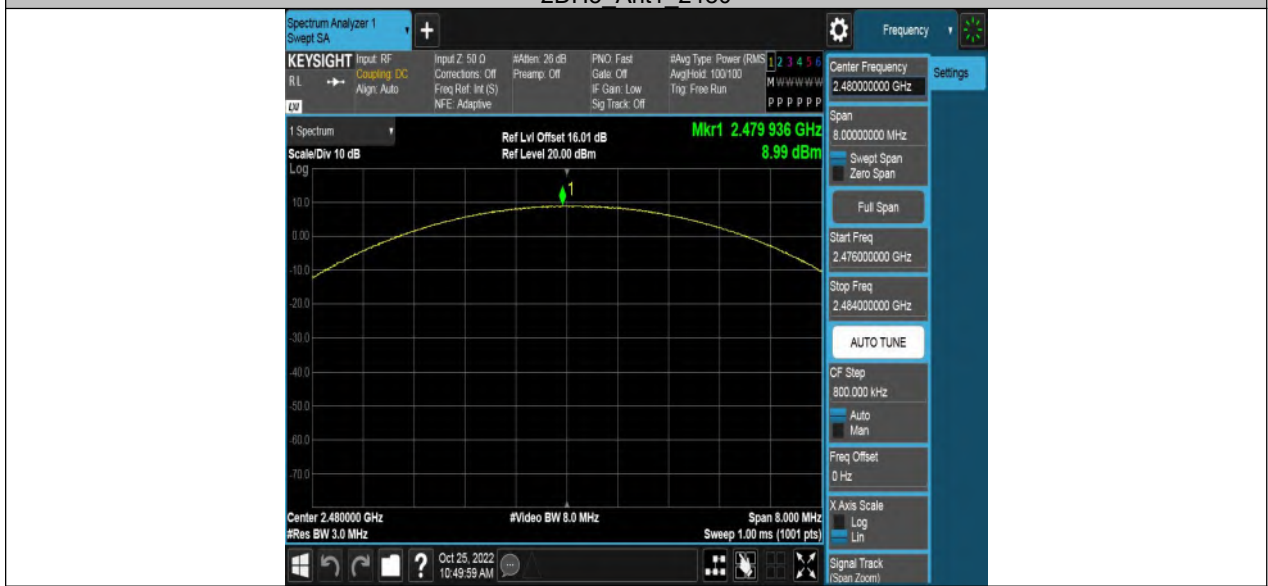

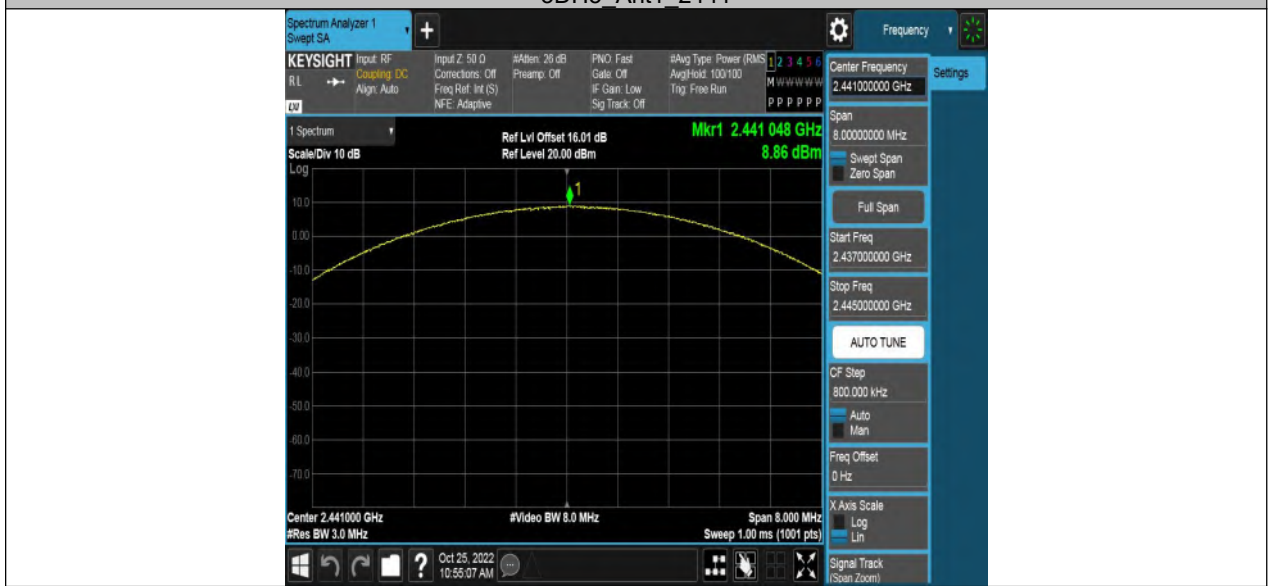
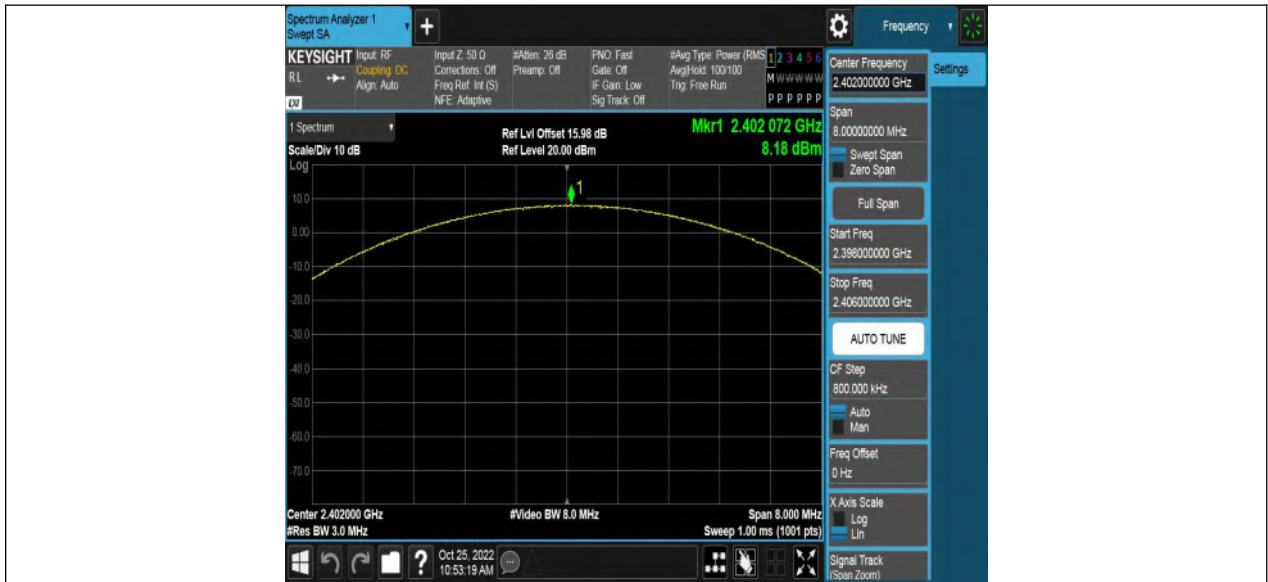

11. Carrier Hopping Channel Separation

11.1. Block diagram of test setup

Same as section 8.1

11.2. Limits

CFR 47 FCC Part15 (15.247) , Subpart C			
Section	Test Item	Limit	Frequency Range (MHz)
CFR 47 FCC 15.247 (a) (1)	Carrier Hopping Channel Separation	Frequency hopping systems shall have hopping channel carrier frequencies separated by a minimum of 25 kHz or the 20 dB bandwidth of the hopping channel, whichever is greater. Alternatively, frequency hopping systems operating in the 2400-2483.5 MHz band may have hopping channel carrier frequencies that are separated by 25 kHz or two-thirds of the 20 dB bandwidth of the hopping channel.	2400-2483.5

11.3. Test Procedure

Connect the UUT to the spectrum Analyzer and use the following settings:

Center Frequency	The center frequency of the channel under test
Span	wide enough to capture the peaks of two adjacent channels
Detector	Peak
RBW	Start with the RBW set to approximately 30 % of the channel spacing; adjust as necessary to best identify the center of each individual channel.
VBW	≥ RBW
Trace	Max hold
Sweep time	Auto couple

Allow the trace to stabilize. Use the marker-delta function to determine the separation between the peaks of the adjacent channels.

Compliance of an EUT with the appropriate regulatory limit shall be determined.

A plot of the data shall be included in the test report.

11.4. Results

Test Mode	Ant.	Freq. (MHz)	Result (MHz)	Limit (MHz)	Verdict
DH5	Ant1	Hop	1.318	≥0.954	PASS
2DH5	Ant1	Hop	1.012	≥0.856	PASS
3DH5	Ant1	Hop	1.14	≥0.864	PASS

11.5. Original test data



12. Number of Hopping Frequency

12.1. Block diagram of test setup

Same as section 8.1

12.2. Limits

CFR 47 FCC Part15 (15.247), Subpart C		
Section	Test Item	Limit
CFR 47 15.247 (a) (1) III	Number of Hopping Frequency	at least 15 hopping channels

12.3. Test Procedure

Connect the EUT to the spectrum Analyzer and use the following settings:

Detector	Peak
RBW	To identify clearly the individual channels, set the RBW to less than 30 % of the channel spacing or the 20 dB bandwidth, whichever is smaller.
VBW	≥RBW
Span	The frequency band of operation
Trace	Max hold
Sweep time	Auto couple

Set EUT to transmit maximum output power and switch on frequency hopping function. then set enough count time (larger than 5000 times) to get all the hopping frequency channel displayed on the screen of spectrum analyzer.

Count the quantity of peaks to get the number of hopping channels.

FHSS Mode: 79 Channels observed.

AFHSS Mode: 20 Channels declared.

12.4. Results

Test Mode	Ant.	Freq. (MHz)	Result (Num)	Limit (Num)	Verdict
DH5	Ant1	Hop	79	≥15	PASS
2DH5	Ant1	Hop	79	≥15	PASS
3DH5	Ant1	Hop	79	≥15	PASS

12.5. Original test data

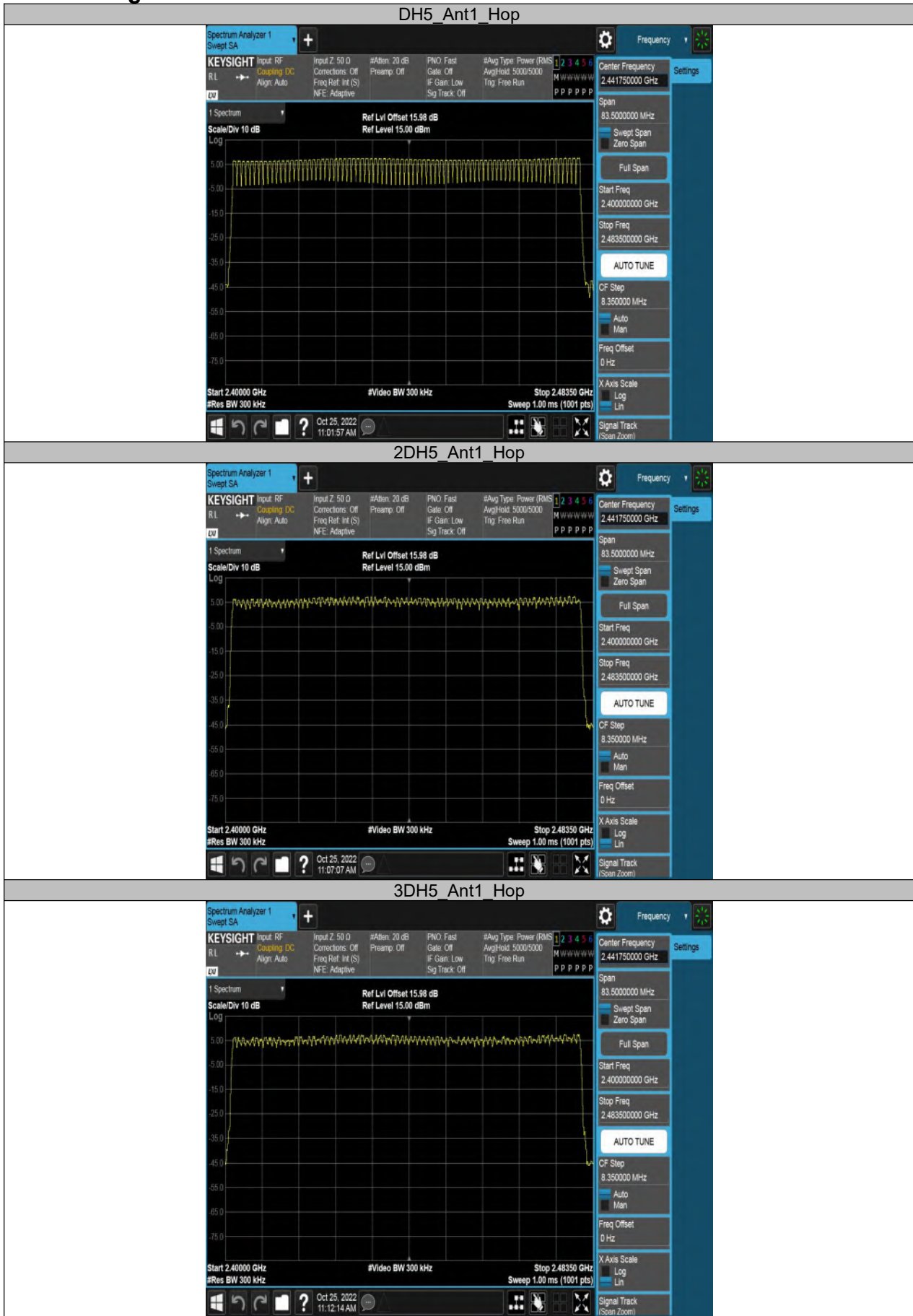

13. Time of Occupancy (Dwell Time)

13.1. Block diagram of test setup

Same as section 8.1

13.2. Limits

CFR 47 FCC Part15 (15.247), Subpart C		
Section	Test Item	Limit
CFR 47 15.247 (a) (1) III	Time of Occupancy (Dwell Time)	The average time of occupancy on any channel shall not be greater than 0.4 seconds within a period of 0.4 seconds, multiplied by the number of hopping channels employed.

13.3. Test Procedure

Connect the UUT to the spectrum Analyzer and use the following settings:

Center Frequency	The center frequency of the channel under test
Detector	Average
RBW	1 MHz
VBW	≥ RBW
Span	zero span
Trace	Clear Write
Sweep time	As necessary to capture the entire dwell time per hopping channel

Connect the UUT to the spectrum Analyzer and use the following settings:

- a. The transmitter output (antenna port) was connected to the spectrum analyzer
- b. Set RBW of spectrum analyzer to 1 MHz and VBW to 3 MHz.
- c. Use a video trigger with the trigger level set to enable triggering only on full pulses.
- d. Sweep Time is more than once pulse time.
- e. Set the center frequency on any frequency would be measure and set the frequency span to zero span.

- f. Measure the maximum time duration of one single pulse.
- g. Set the EUT for DH5, DH3 and DH1 packet transmitting.
- h. Measure the maximum time duration of one single pulse.

A Period Time = (channel number)*0.4

For FHSS Mode (79 Channel):

DH1 Time Slot: Reading * (1600/2)*31.6/(channel number)

DH3 Time Slot: Reading * (1600/4)*31.6/(channel number)

DH5 Time Slot: Reading * (1600/6)*31.6/(channel number)

13.4. Results

Test Mode	Ant.	Freq. (MHz)	Burst Width (ms)	Total Hops (Num)	Result (s)	Limit (s)	Verdict
DH1	Ant1	Hop	0.370	320	0.118	≤0.4	PASS
DH3	Ant1	Hop	1.620	160	0.259	≤0.4	PASS
DH5	Ant1	Hop	2.870	106.67	0.306	≤0.4	PASS
2DH1	Ant1	Hop	0.380	320	0.122	≤0.4	PASS
2DH3	Ant1	Hop	1.630	160	0.261	≤0.4	PASS
2DH5	Ant1	Hop	2.880	106.67	0.307	≤0.4	PASS
3DH1	Ant1	Hop	0.380	320	0.122	≤0.4	PASS
3DH3	Ant1	Hop	1.630	160	0.261	≤0.4	PASS
3DH5	Ant1	Hop	2.880	106.67	0.307	≤0.4	PASS

13.5. Original test data



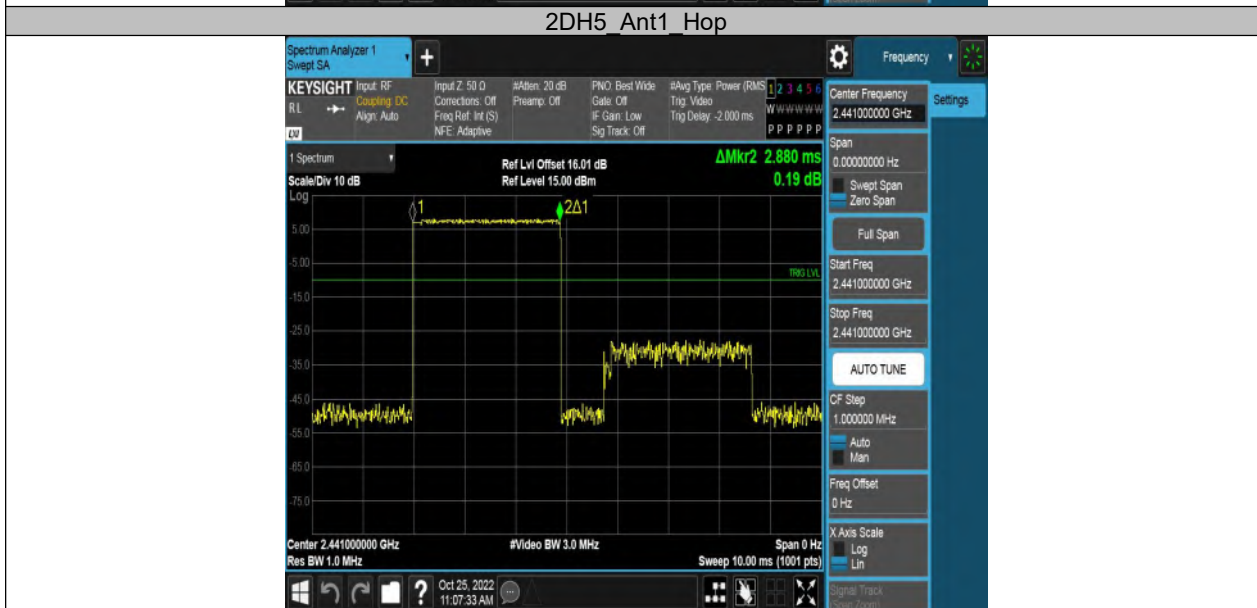
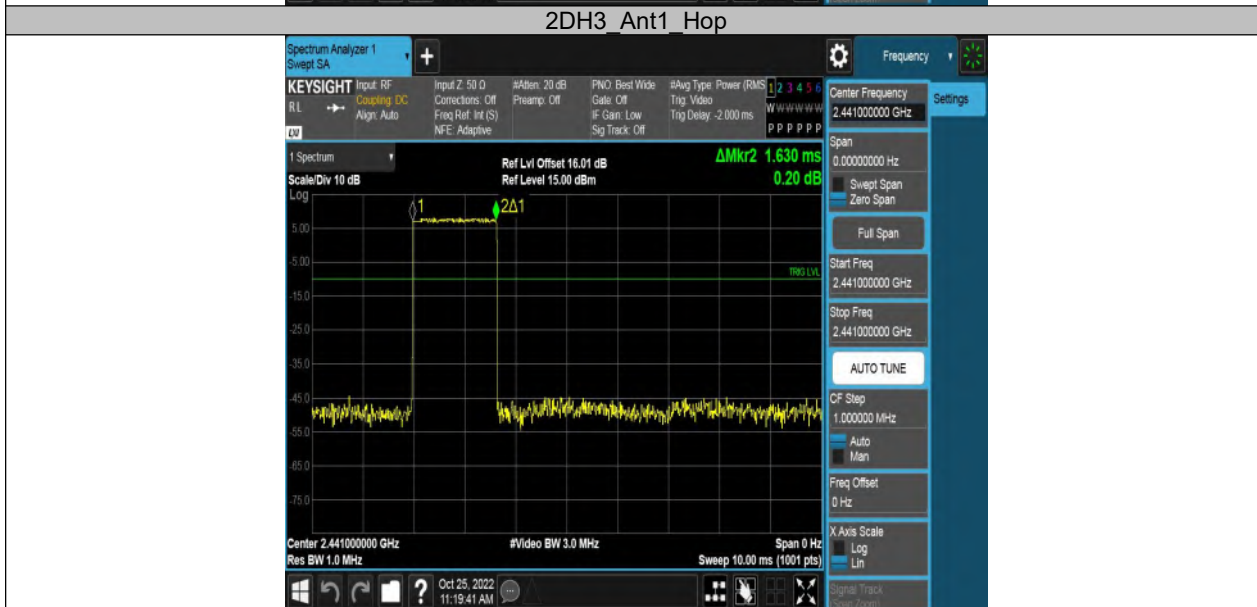

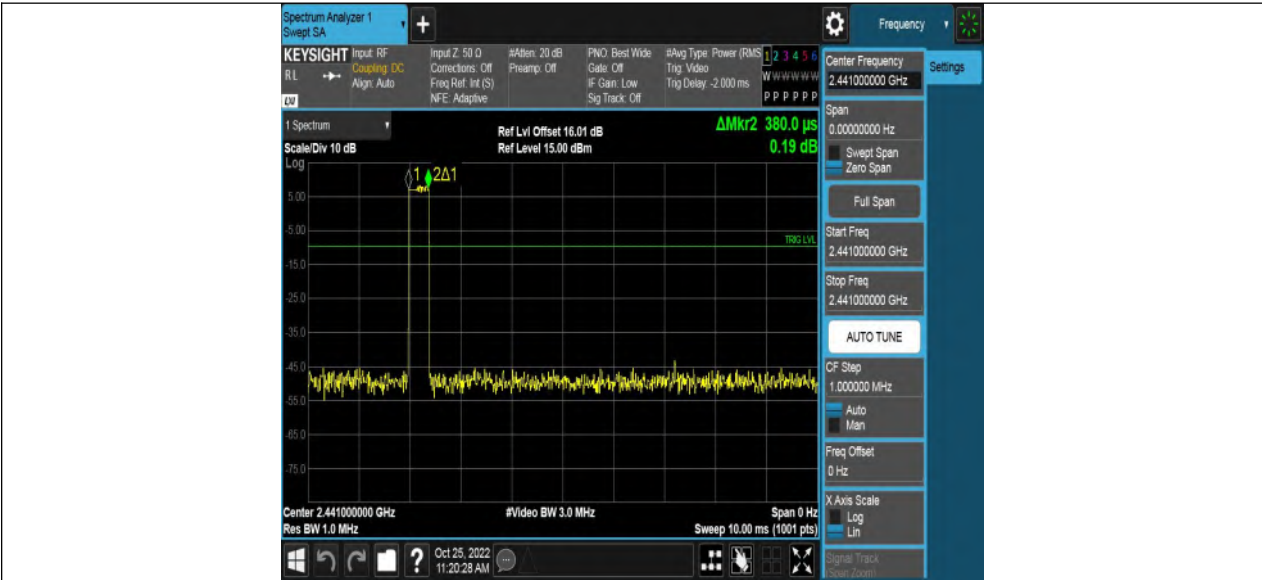

3DH3 Ant1 Hop



3DH5 Ant1 Hop



14. Conducted Spurious Emission

14.1. Block diagram of test setup

Same as section 8.1

14.2. Limits

CFR 47 FCC Part15 (15.247), Subpart C		
Section	Test Item	Limit
CFR 47 FCC §15.247 (d)	Conducted Spurious Emission	at least 20 dB below that in the 100 kHz bandwidth within the band that contains the highest level of the desired power

14.3. Test Procedure

Please refer to the ANSI C63.10 section 6.10.

For Band edge use the following settings:

Detector	Peak
RBW	100 kHz
VBW	300 kHz
Span	wide enough to fully capture the emission being measured
Trace	Max hold
Sweep time	Auto couple.

For Spurious Emission use the following settings:

Detector	Peak
RBW	100 kHz
VBW	300 kHz
Span	wide enough to fully capture the emission being measured
Trace	Max hold
Sweep time	Auto couple.

Use the peak marker function to determine the maximum amplitude level.

14.4. Results

Band edge:

Test Mode	Ant.	Ch Name	Freq. (MHz)	Ref Level (dBm)	Result (dBm)	Limit (dBm)	Verdict
DH5	Ant1	Low	2402	6.54	-38.13	≤-13.46	PASS
		High	2480	7.74	-44.34	≤-12.26	PASS
		Low	Hop_2402	6.17	-35.53	≤-13.83	PASS
		High	Hop_2480	7.69	-35.45	≤-12.31	PASS
2DH5	Ant1	Low	2402	6.32	-38.83	≤-13.68	PASS
		High	2480	7.59	-43.87	≤-12.41	PASS
		Low	Hop_2402	5.41	-35.89	≤-14.59	PASS
		High	Hop_2480	5.35	-39.83	≤-14.65	PASS
3DH5	Ant1	Low	2402	6.26	-41.63	≤-13.74	PASS
		High	2480	7.53	-43.58	≤-12.47	PASS
		Low	Hop_2402	6.22	-36.18	≤-13.78	PASS
		High	Hop_2480	7.46	-37.11	≤-12.54	PASS

Spurious Emission:

Test Mode	Ant.	Freq. (MHz)	Freq Range (MHz)	Ref Level (dBm)	Result (dBm)	Limit (dBm)	Verdict
DH5	Ant1	2402	30~1000	6.54	-56.67	≤-13.46	PASS
			1000~26500	6.54	-31.7	≤-13.46	PASS
		2441	30~1000	7.24	-56.1	≤-12.76	PASS
			1000~26500	7.24	-27.52	≤-12.76	PASS
		2480	30~1000	7.74	-56.5	≤-12.26	PASS
			1000~26500	7.74	-41.93	≤-12.26	PASS
2DH5	Ant1	2402	30~1000	6.32	-57.23	≤-13.68	PASS
			1000~26500	6.32	-33.89	≤-13.68	PASS
		2441	30~1000	7.11	-56.27	≤-12.89	PASS
			1000~26500	7.11	-35.44	≤-12.89	PASS
		2480	30~1000	7.59	-56.82	≤-12.41	PASS
			1000~26500	7.59	-36.62	≤-12.41	PASS
3DH5	Ant1	2402	30~1000	6.26	-56.59	≤-13.74	PASS
			1000~26500	6.26	-43.48	≤-13.74	PASS
		2441	30~1000	7.03	-56.58	≤-12.97	PASS
			1000~26500	7.03	-27.03	≤-12.97	PASS
		2480	30~1000	7.53	-56.29	≤-12.47	PASS
			1000~26500	7.53	-39.59	≤-12.47	PASS

14.5. Original test data

Band edge:





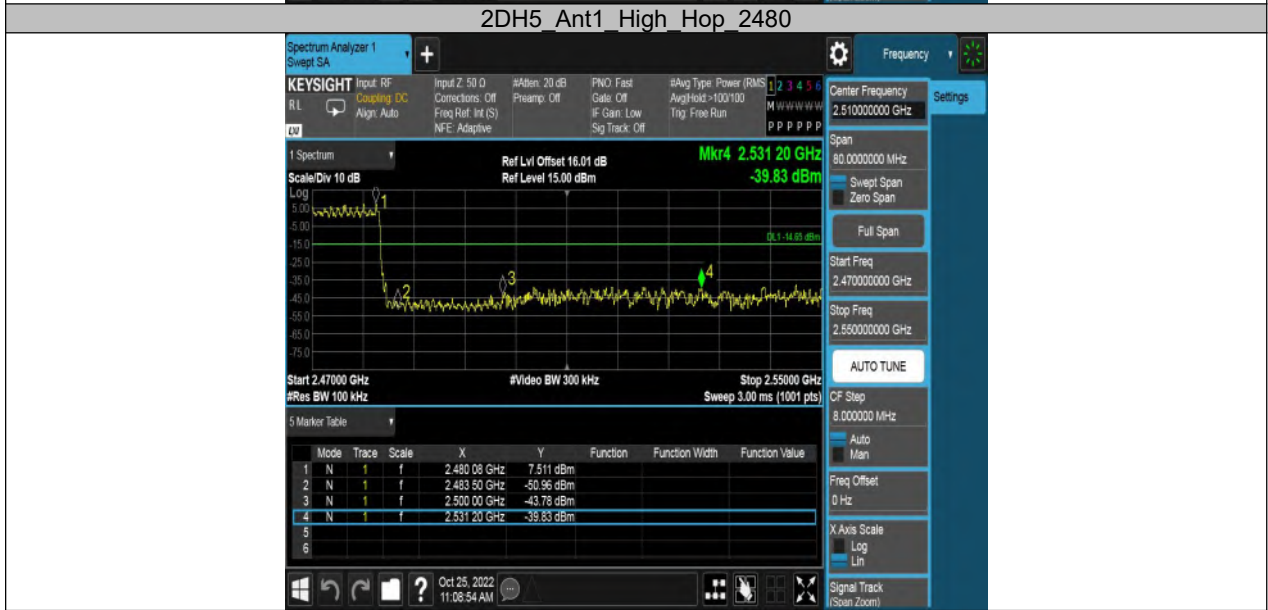

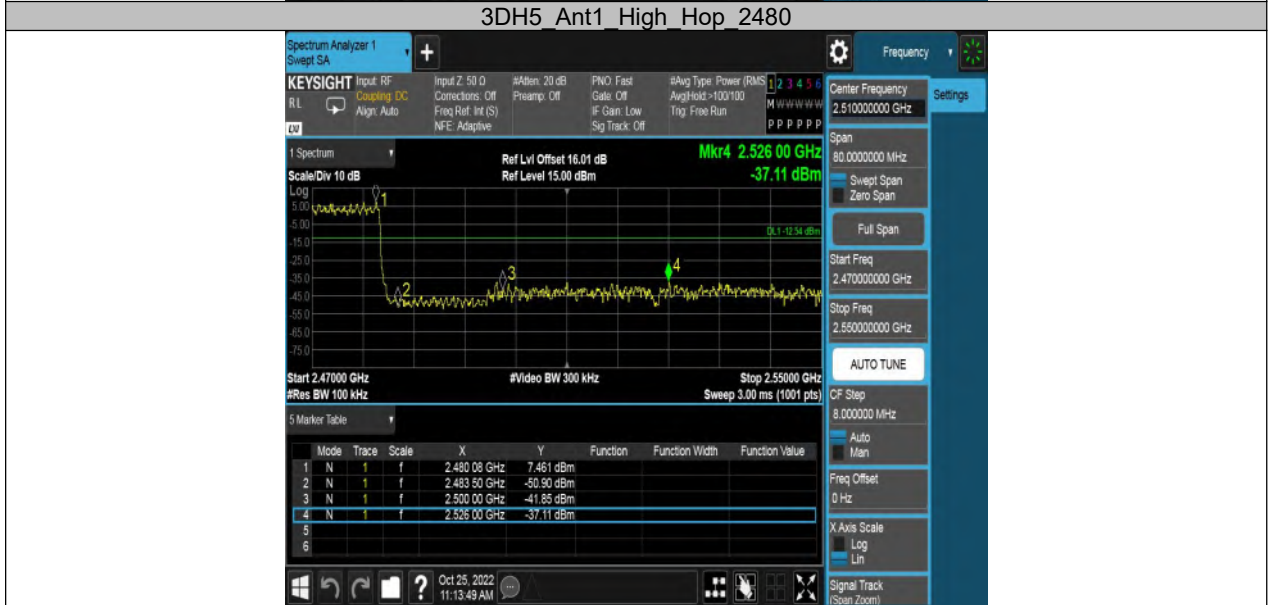
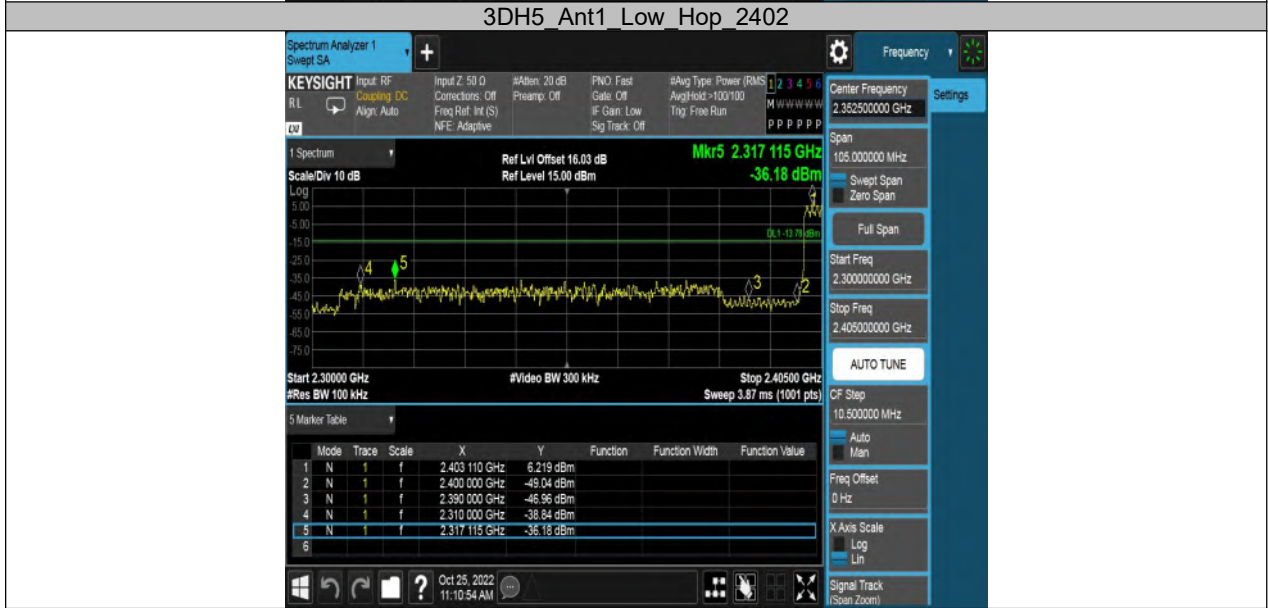
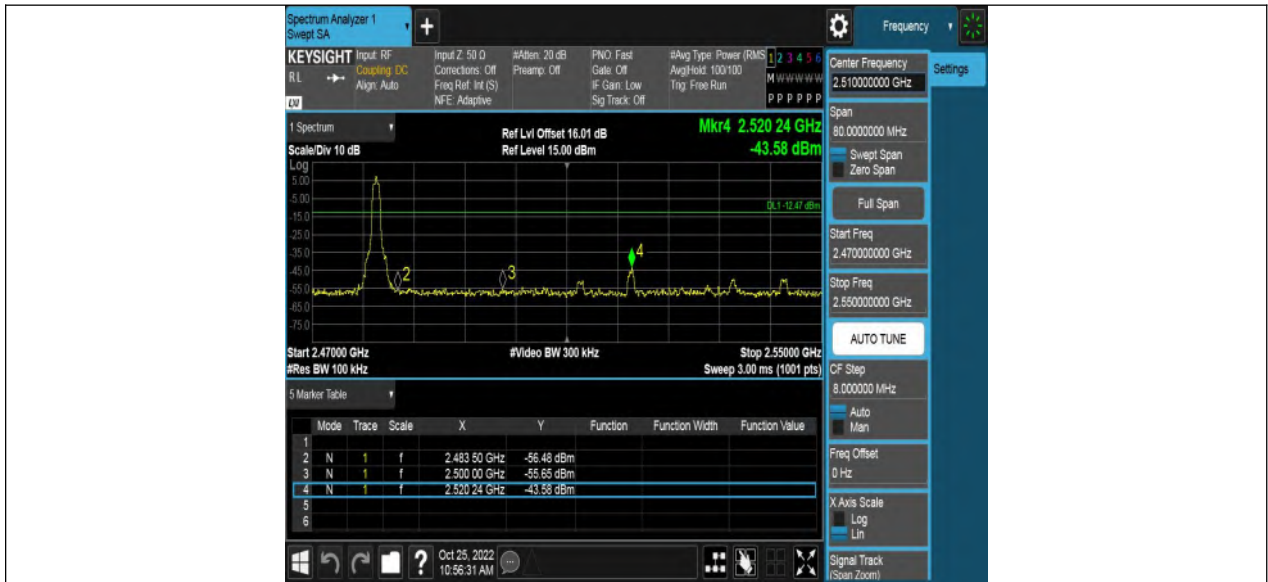

Spurious Emission:

3DH5 Ant1 2402 30~1000

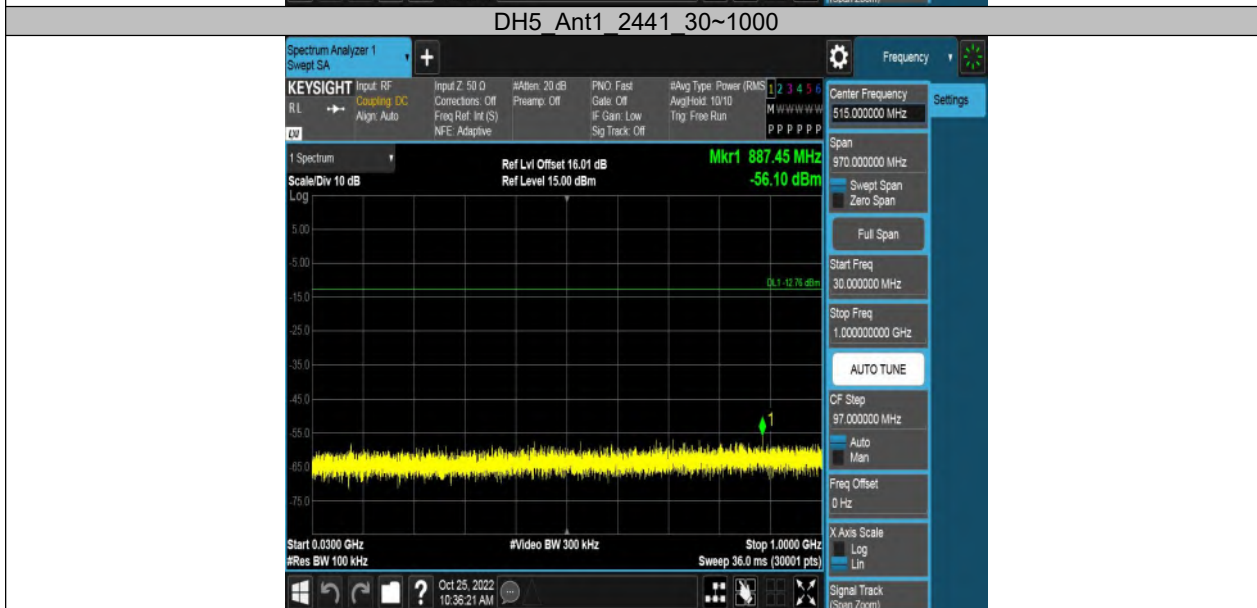



DH5 Ant1 2480 30~1000



DH5 Ant1 2480 1000~26500

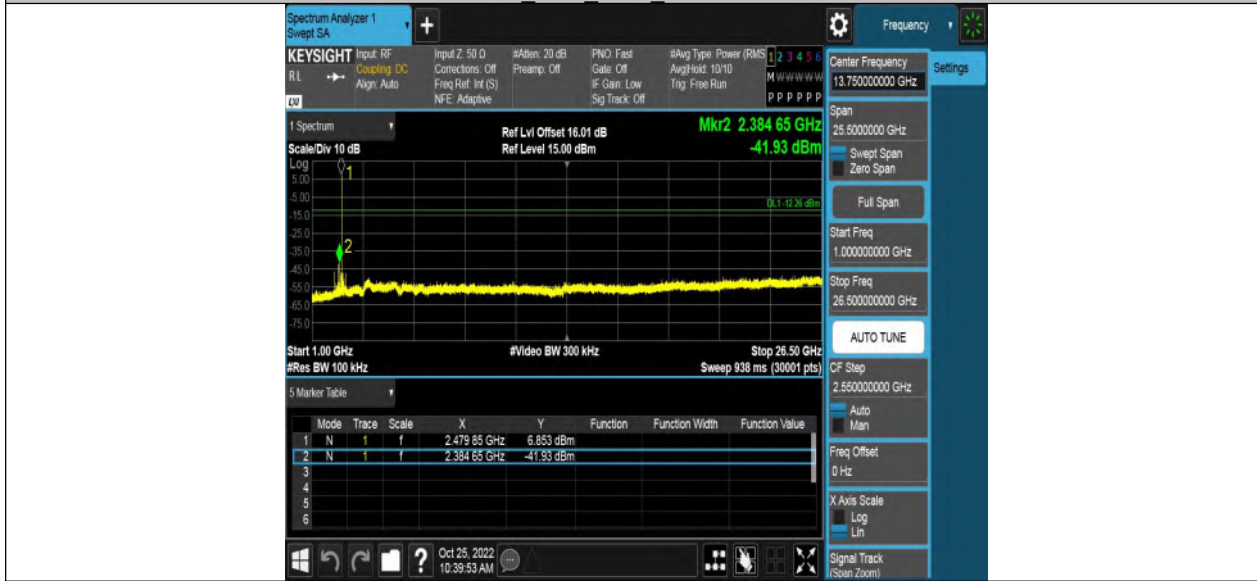

2DH5 Ant1 2402 30~1000

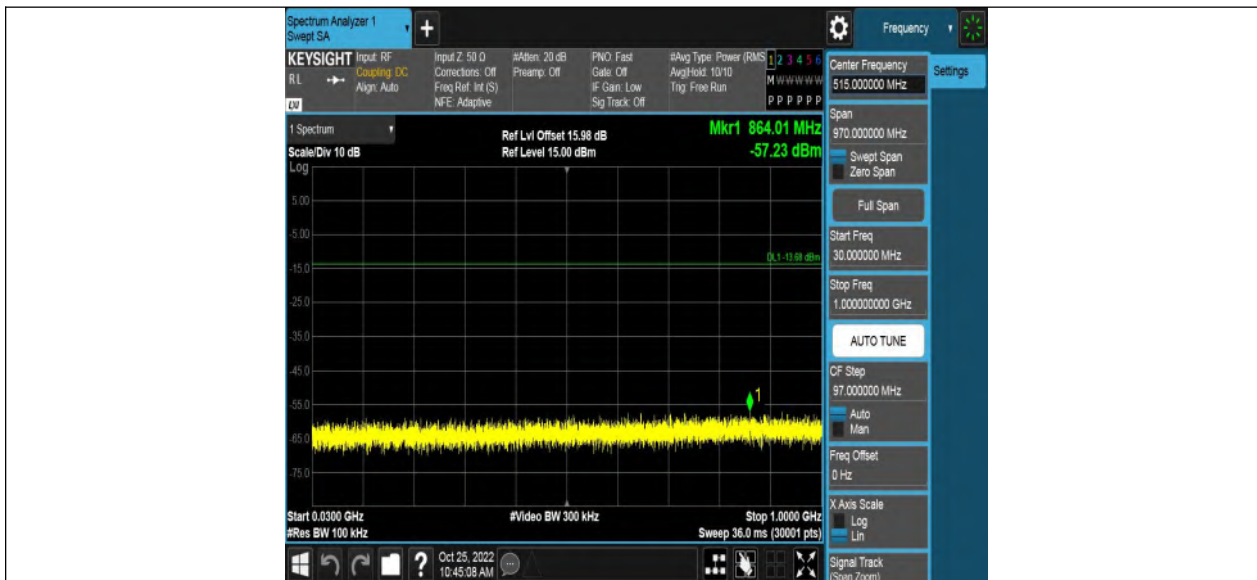







15. Radiated Emission

15.1. Block diagram of test setup

In 3m Anechoic Chamber, test setup diagram for 9kHz - 30MHz:

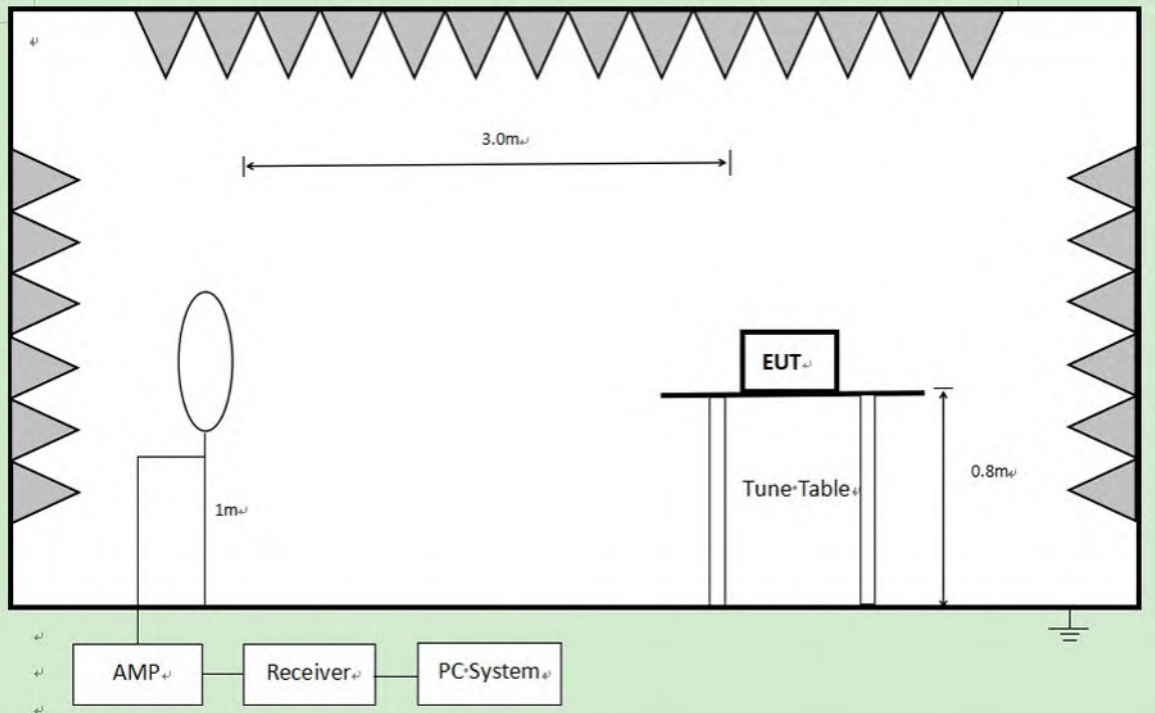

In 3m Anechoic Chamber, test setup diagram for 30 MHz - 1 GHz:

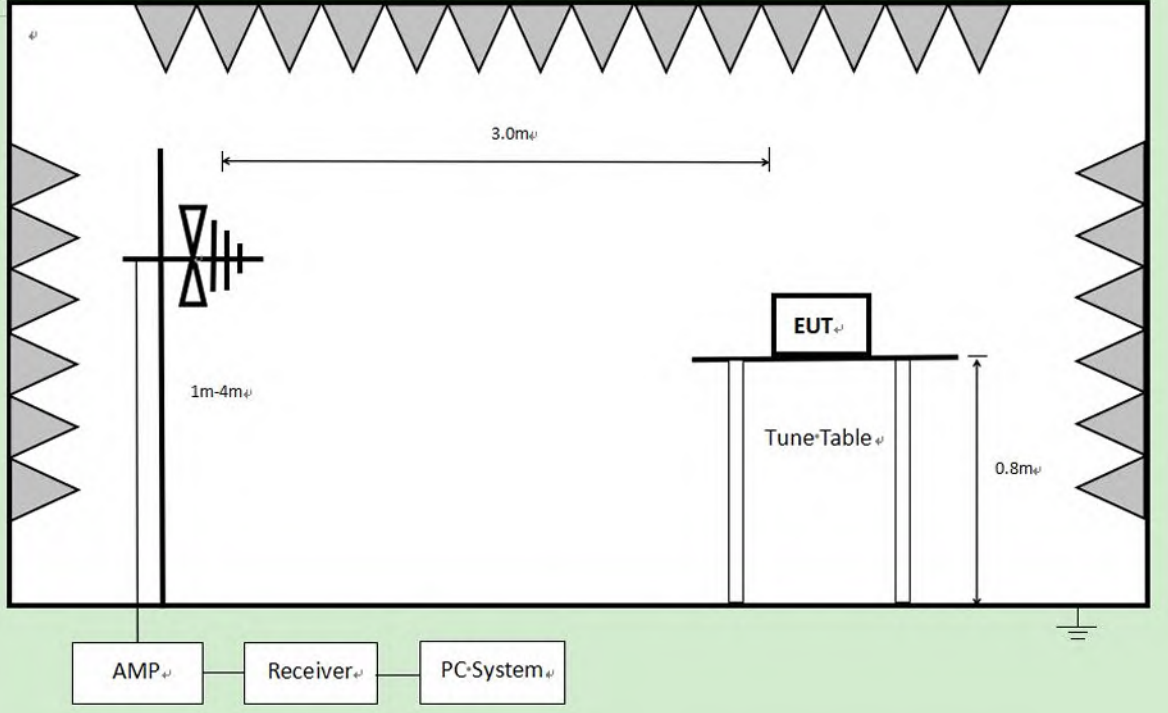

In 3m Anechoic Chamber, test setup diagram for frequency above 1 GHz:

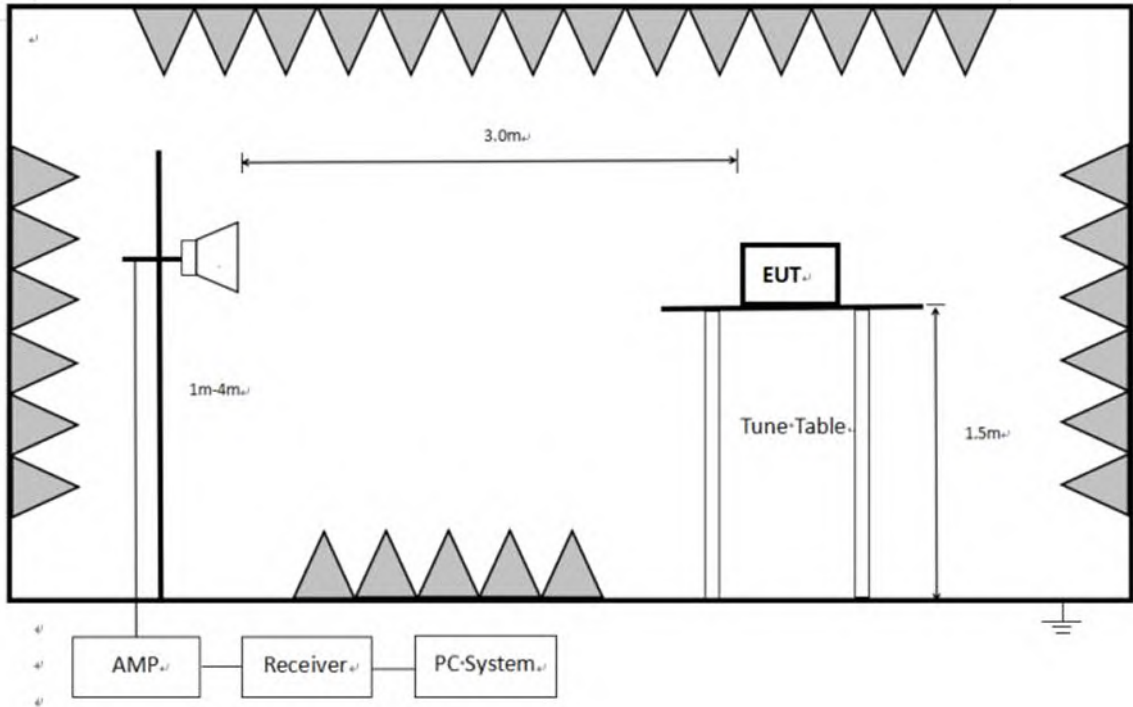

Note: For harmonic emissions test an appropriate high pass filter was inserted in the input port of AMP.

15.2. Limit

(1) FCC 15.205 Restricted frequency band

MHz	MHz	MHz	GHz
0.090-0.110	16.42-16.423	399.9-410	4.5-5.15
¹ 0.495-0.505	16.69475-16.69525	608-614	5.35-5.46
2.1735-2.1905	16.80425-16.80475	960-1240	7.25-7.75
4.125-4.128	25.5-25.67	1300-1427	8.025-8.5
4.1772&4.17775	37.5-38.25	1435-1626.5	9.0-9.2
4.2072&4.20775	73-74.6	1645.5-1646.5	9.3-9.5
6.215-6.218	74.8-75.2	1660-1710	10.6-12.7
6.26775-6.26825	108-121.94	1718.8-1722.2	13.25-13.4
6.31175-6.31225	123-138	2200-2300	14.47-14.5
8.291-8.294	149.9-150.05	2310-2390	15.35-16.2
8.362-8.366	156.52475-156.52525	2483.5-2500	17.7-21.4
8.37625-8.38675	156.7-156.9	2690-2900	22.01-23.12
8.41425-8.41475	162.0125-167.17	3260-3267	23.6-24.0
12.29-12.293	167.72-173.2	3332-3339	31.2-31.8
12.51975-12.52025	240-285	3345.8-3358	36.43-36.5
12.57675-12.57725	322-335.4	3600-4400	(²)
13.36-13.41			

¹Until February 1, 1999, this restricted band shall be 0.490-0.510 MHz.

²Above 38.6

(2) FCC 15.209 Limit.

Frequency MHz	Distance Meters	Field Strengths Limit	
		$\mu\text{V}/\text{m}$	$\text{dB}(\mu\text{V})/\text{m}$
0.009 ~ 0.490	300	$2400/F(\text{kHz})$	$67.6-20\log(F)$
0.490 ~ 1.705	30	$24000/F(\text{kHz})$	$87.6-20\log(F)$
1.705 ~ 30.0	30	30	29.54
30 ~ 88	3	100	40.0
88 ~ 216	3	150	43.5
216~960	3	200	46.0
960~1000	3	500	54.0
Above 1000	3	74.0 $\text{dB}(\mu\text{V})/\text{m}$ (Peak) 54.0 $\text{dB}(\mu\text{V})/\text{m}$ (Average)	

Note: 1) At frequencies at or above 30 MHz, measurements may be performed at a distance other than what is specified provided: measurements are not made in the near field except where it can be shown that near field measurements are appropriate due to the characteristics of the device; and it can be demonstrated that the signal levels needed to be measured at the distance employed can be detected by the measurement equipment. Measurements shall not be performed at a distance greater than 30 meters unless it can be further demonstrated that measurements at a distance of 30 meters or less are impractical. When performing measurements at a distance other than that specified, the results shall be extrapolated to the specified distance using an extrapolation factor of 20 dB/decade (inverse linear-distance for field strength measurements; inverse-linear-distance-squared for power density measurements).

(2) At frequencies below 30 MHz, measurements may be performed at a distance closer than that specified in the regulations; however, an attempt should be made to avoid making measurements in the near field. Pending the development of an appropriate measurement procedure for measurements performed below 30 MHz, when performing measurements at a closer distance than specified, the results shall be extrapolated to the specified distance by either making measurements at a minimum of two distances on at least one radial to determine the proper extrapolation factor or by using the square of an inverse linear distance extrapolation factor (40 dB/decade). This paragraph (f) shall not apply to Access BPL devices operating below 30 MHz.

About Restricted bands of operation please refer to FCC § 15.205 (a),

15.3. Test Procedure

Below 30 MHz:

The setting of the spectrum Analyzer

RBW	200 Hz (From 9 kHz to 0.15 MHz)/ 9 kHz (From 0.15 MHz to 30 MHz)
VBW	200 Hz (From 9 kHz to 0.15 MHz)/ 9 kHz (From 0.15 MHz to 30 MHz)
Sweep	Auto
Trace	Max hold

1. The testing follows the guidelines in ANSI C63.10-2013
2. The EUT was arranged to its worst case and then turntable (from 0 degree to 360 degrees) to find the maximum reading. A pre-amp and a high pass filter are used for the test in order to get better signal level. Both Horizontal, Face-on and Face-off polarizations of the antenna are set to make the measurement.
3. The EUT was placed on a turntable with 80 cm meter above ground.
4. The EUT was set 3 meters from the interference receiving antenna, which was mounted on the top of 1 meter height antenna tower.
5. The radiated emission limits are based on measurements employing a CISPR quasi-peak detector except for the frequency bands 9-90 kHz, 110-490 kHz and above 1000 MHz. Radiated emission limits in these three bands are based on measurements employing an average detector.
6. For measurement below 1 GHz, the initial step in collecting conducted emission data is a spectrum analyzer peak detector mode pre-scanning the measurement frequency range. Significant peaks are then marked and then Quasi Peak detector mode re-measured. If the emission level of the EUT measured by the peak detector is 3 dB lower than the applicable limit, the peak emission level will be reported. Otherwise, the emission measurement will be repeated using the quasi-peak detector and reported.
7. Although these tests were performed other than open field site, adequate comparison measurements were confirmed against 30m open field site. Therefore, sufficient tests were made to demonstrate that the alternative site produces results that correlate with the ones of tests made in an open field site based on KDB 414788.

Below 1 GHz and above 30 MHz:
The setting of the spectrum Analyzer

RBW	120 kHz
VBW	300 kHz
Sweep	Auto
Trace	Max hold

1. The testing follows the guidelines in ANSI C63.10-2013.
2. The EUT was arranged to its worst case and then tune the antenna tower (from 1 m to 4 m) and turntable (from 0 degree to 360 degrees) to find the maximum reading. A pre-amp and a high pass filter are used for the test in order to get better signal level. Both horizontal and vertical polarizations of the antenna are set to make the measurement.
3. The EUT was placed on a turntable with 80 cm above ground.
4. The EUT was set 3 meters from the interference receiving antenna, which was mounted on the top of a variable height antenna tower.
5. For measurement below 1GHz, the initial step in collecting conducted emission data is a spectrum analyzer peak detector mode pre-scanning the measurement frequency range. Significant peaks are then marked and then Quasi Peak detector mode re-measured. If the emission level of the EUT measured by the peak detector is 3 dB lower than the applicable limit, the peak emission level will be reported. Otherwise, the emission measurement will be repeated using the quasi-peak detector and reported.

Above 1 GHz:

RBW	1 MHz
VBW	PEAK: 3 MHz AVG: see note 6
Sweep	Auto
Detector	Peak
Trace	Max hold

1. The testing follows the guidelines in ANSI C63.10-2013.

2. The EUT was arranged to its worst case and then tune the antenna tower (from 1 m to 4 m) and turntable (from 0 degree to 360 degrees) to find the maximum reading. A pre-amp and a high pass filter are used for the test in order to get better signal level. Both horizontal and vertical polarizations of the antenna are set to make the measurement.

3. The EUT was placed on a turntable with 1.5m above ground.

4. The EUT was set 3 meters from the interference receiving antenna, which was mounted on the top of a variable height antenna tower.

5. For measurement above 1GHz, the emission measurement will be measured by the peak detector. This peak level, once corrected, must comply with the limit specified in Section 15.209.

6. For measurements above 1 GHz the resolution bandwidth is set to 1 MHz, then the video bandwidth is set to 3 MHz for peak measurements and 1 MHz resolution bandwidth with 1/T video bandwidth with peak detector for AVG measurements. For the Duty Cycle please refer to clause 7.1. On Time And Duty Cycle.

7. Restriction band: Investigated frequency range from 2310 MHz to 2410 MHz and 2470MHz to 2500 MHz.

All restriction band should comply with 15.209, other emission should be at least 20 dB below the fundamental.

Note 1: For all radiated test, EUT in each of three orthogonal axis emissions had been tested, but only the worst case (X axis) data recorded in the report.

Note 2: The EUT does not support simultaneous transmission.

Note 3: The EUT was fully exercised with external accessories during the test. In the case of multiple accessory external ports, an external accessory shall be connected to one of each type of port.

15.4. Results

Pass. (See below detailed test result)

All the emissions except fundamental emission from 9 kHz to 25 GHz were comply with 15.209 limits.

Note1: According exploratory test, the emission levels are 20 dB below the limit detected from 9 kHz to 30 MHz, so the final test was performed with frequency range from 30 MHz to 26 GHz and recorded in below.

Note2: For emissions below 1 GHz, according exploratory explorer test, when change Tx mode and channel, have no distinct influence on emissions level, so for emissions below 1 GHz, the final test was only performed with EUT working in 8DPSK, TX 2480 MHz mode.

Note3: For emissions above 1 GHz. If peak results comply with AV limit, AV Result is deemed to comply with AV limit.

15.5. Original test data

Below 1 GHz and above 30 MHz test data Refer to appendix A

Above 1 GHz test data Refer to appendix B

16. AC Power Line Conducted Emissions

16.1. Block diagram of test setup

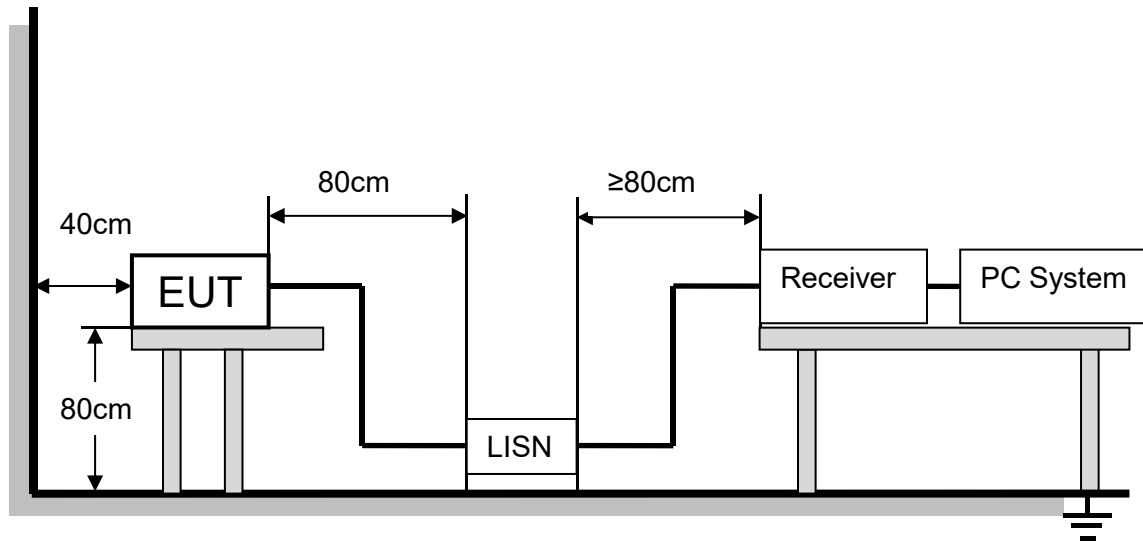

The EUT is put on a table of non-conducting material that is 80 cm high. The vertical conducting wall of shielding is located 40 cm to the rear of the EUT. The power line of the EUT is connected to the AC mains through an Artificial Mains Network (A.M.N.). A EMI Measurement Receiver (R&S Test Receiver ESR3) is used to test the emissions from both sides of AC line. According to the requirements in Section 6.2 of ANSI C63.10-2013. Conducted emissions from the EUT measured in the frequency range between 0.15 MHz and 30 MHz using CISPR Quasi-Peak and average detector mode. The bandwidth of EMI test receiver is set at 9 kHz.

The arrangement of the equipment is installed to meet the standards and operating in a manner, which tends to maximize its emission characteristics in a normal application.

16.2. Limits

Please refer to CFR 47 FCC § 15.207 (a).

Frequency (MHz)	Quasi-peak	Average
0.15 -0.5	66 - 56 *	56 - 46 *
0.50 -5.0	56.00	46.00
5.0 -30.0	60.00	50.00

Note 1: * Decreasing linearly with logarithm of frequency.

Note 2: The lower limit shall apply at the transition frequencies.

16.3. Test procedure

The EUT and Support equipment, if needed, were put placed on a non-metallic table, 80cm above the ground plane.

Configuration EUT to simulate typical usage as described in clause 2.4 and test equipment as described in clause 10.2 of this report.

All I/O cables were positioned to simulate typical actual usage as per ANSI C63.10.

All support equipment power received from a second LISN.

Emissions were measured on each current carrying line of the EUT using an EMI Test Receiver connected to the LISN powering the EUT.

The Receiver scanned from 150 kHz to 30 MHz for emissions in each of the test modes.

During the above scans, the emissions were maximized by cable manipulation.

The test mode(s) described in clause 2.4 were scanned during the preliminary test.

After the preliminary scan, we found the test mode producing the highest emission level.

The EUT configuration and worse cable configuration of the above highest emission levels were recorded for reference of the final test.

EUT and support equipment were set up on the test bench as per the configuration with highest emission level in the preliminary test.

A scan was taken on both power lines, Neutral and Line, recording at least the six highest emissions.

Emission frequency and amplitude were recorded into a computer in which correction factors were used to calculate the emission level and compare reading to the applicable limit.

The test data of the worst-case condition(s) was recorded.

The bandwidth of test receiver is set at 9 kHz.

16.4. Test result

NA

Note: The conducted emission tests at AC port are not required test.

17. Antenna Requirements

17.1. Limits

Please refer to FCC § 15.203

An intentional radiator shall be designed to ensure that no antenna other than that furnished by the responsible party shall be used with the device. The use of a permanently attached antenna or of an antenna that uses a unique coupling to the intentional radiator shall be considered sufficient to comply with the provisions of this section. The manufacturer may design the unit so that a broken antenna can be replaced by the user, but the use of a standard antenna jack or electrical connector is prohibited.

Please refer to FCC § 15.247(b)(4)

The conducted output power limit specified in paragraph (b) of this section is based on the use of antennas with directional gains that do not exceed 6 dBi. Except as shown in paragraph (c) of this section, if transmitting antennas of directional gain greater than 6 dBi are used, the conducted output power from the intentional radiator shall be reduced below the stated values in paragraphs (b)(1), (b)(2), and (b)(3) of this section, as appropriate, by the amount in dB that the directional gain of the antenna exceeds 6 dBi.

17.2. Result

The antenna used for this product is PCB antenna and that no antenna other than that furnished by the responsible party shall be used with the device, the maximum peak gain of the transmit antenna is - 3.0 dBi

APPENDIX A – Radiated Emission Below 1GHz Test Data

Test Report

Project Information			
EUT:	Car Audio Navigation	Environment:	25°C/58%
Model:	M903AT-11T	SN:	
Mode:	3DH5_2480	Voltage:	12V/10A
Customer:		Engineer:	Roger
Remark:			
Test Standard:			

Start of Test: 2022-10-28 17:57:41

Test Graph

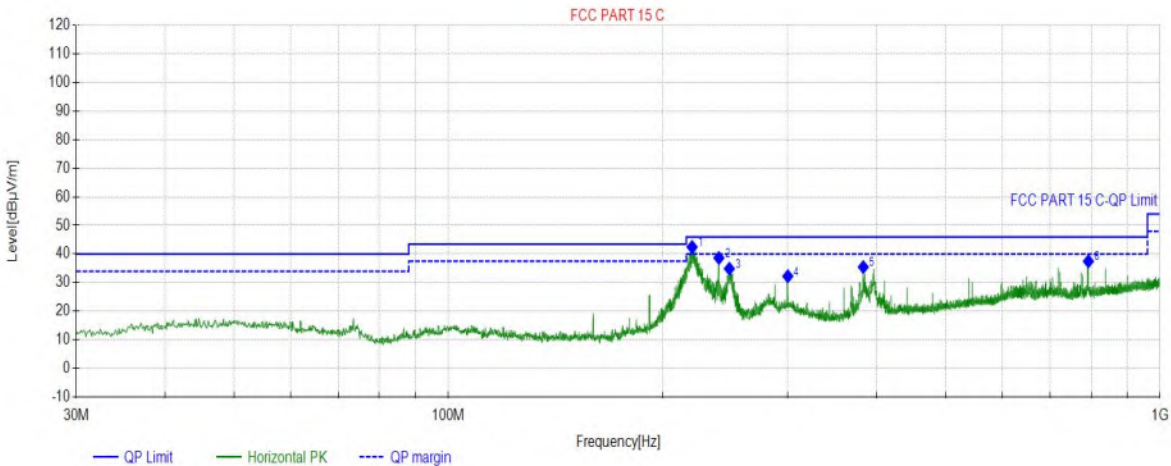

Final Data List								
NO.	Freq. (MHz)	Factor (dB)	QP Value (dBµV/m)	QP Limit (dBµV/m)	QP Margin (dB)	Height (cm)	Angle (°)	Polarity
1	220.0420	-21.83	42.46	46.00	3.54	100	102	Horizontal
2	240.0260	-20.70	38.64	46.00	7.36	100	110	Horizontal
3	248.2718	-20.53	34.87	46.00	11.13	100	333	Horizontal
4	299.9780	-19.46	32.26	46.00	13.74	100	268	Horizontal
5	382.9213	-16.95	35.46	46.00	10.54	100	106	Horizontal
6	793.1753	-9.21	37.49	46.00	8.51	100	115	Horizontal

Test Report

Project Information			
EUT:	Car Audio Navigation	Environment:	25°C/58%
Model:	M903AT-11T	SN:	
Mode:	3DH5_2480	Voltage:	12V/10A
Customer:		Engineer:	Roger
Remark:			
Test Standard:			

Start of Test: 2022-10-28 17:58:24

Test Graph

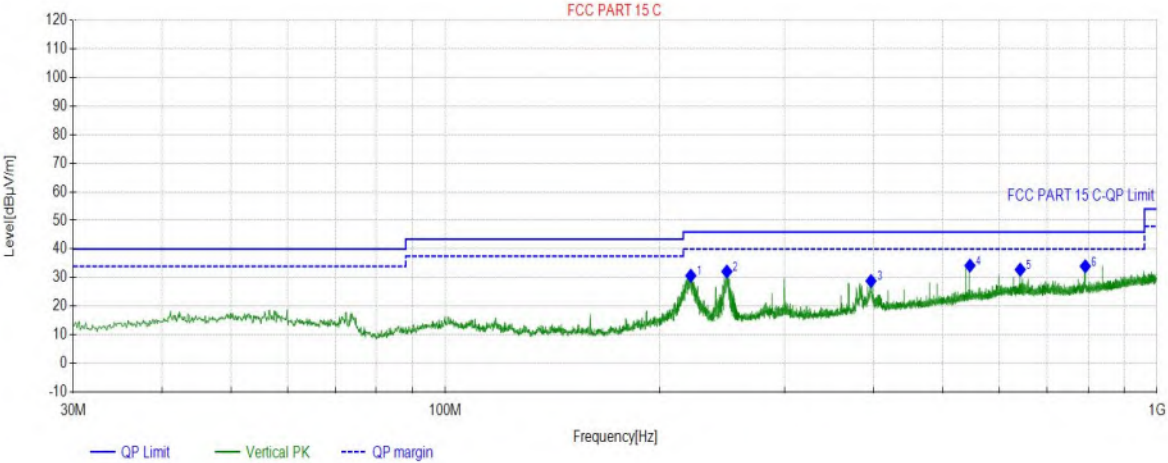

Final Data List								
NO.	Freq. (MHz)	Factor (dB)	QP Value (dBµV/m)	QP Limit (dBµV/m)	QP Margin (dB)	Height (cm)	Angle (°)	Polarity
1	221.3031	-21.76	30.68	46.00	15.32	100	333	Vertical
2	248.6599	-20.52	32.14	46.00	13.86	100	333	Vertical
3	396.4056	-16.50	28.84	46.00	17.16	100	38	Vertical
4	545.9946	-13.09	34.22	46.00	11.78	100	84	Vertical
5	642.4222	-11.33	32.80	46.00	13.20	100	3	Vertical
6	792.7873	-9.22	33.99	46.00	12.01	100	206	Vertical

For model: M903AT-10T:

Test Report

Project Information			
EUT:	Car Audio Navigation	Environment:	25°C/58%
Model:	M903AT-10T	SN:	
Mode:	3DH5_2480	Voltage:	12V/10A
Customer:		Engineer:	
Remark:			
Test Standard:			

Start of Test: 2022-12-20 16:45:48

Test Graph

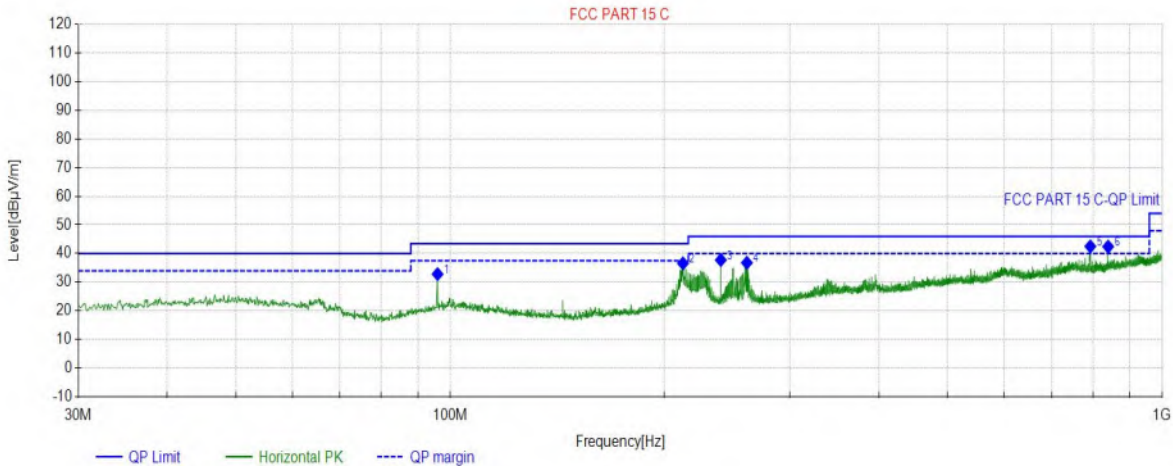

Final Data List								
NO.	Freq. (MHz)	Factor (dB)	QP Value (dBµV/m)	QP Limit (dBµV/m)	QP Margin (dB)	Height (cm)	Angle (°)	Polarity
1	95.9666	19.85	32.83	43.50	10.67	200	27	Horizontal
2	212.2812	20.78	36.57	43.50	6.93	100	301	Horizontal
3	239.9290	22.04	37.76	46.00	8.24	100	86	Horizontal
4	261.0771	22.34	36.79	46.00	9.21	100	109	Horizontal
5	793.0783	32.51	42.51	46.00	3.49	100	177	Horizontal
6	840.0310	33.25	42.42	46.00	3.58	100	173	Horizontal

Test Report

Project Information			
EUT:	Car Audio Navigation	Environment:	25°C/58%
Model:	M903AT-10T	SN:	
Mode:	3DH5_2480	Voltage:	12V/10A
Customer:		Engineer:	
Remark:			
Test Standard:			

Start of Test: 2022-12-20 16:53:20

Test Graph

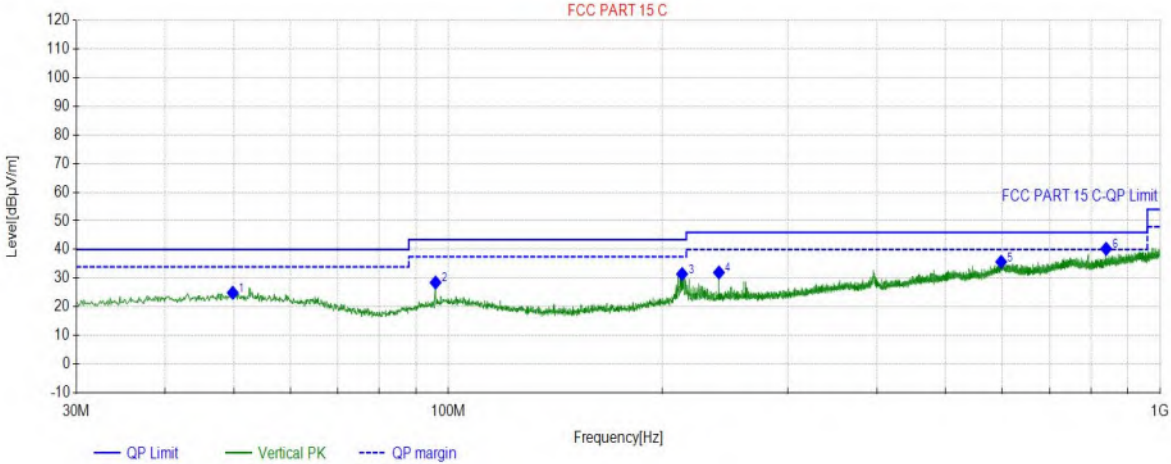

Final Data List								
NO.	Freq. (MHz)	Factor (dB)	QP Value (dBµV/m)	QP Limit (dBµV/m)	QP Margin (dB)	Height (cm)	Angle (°)	Polarity
1	49.7900	22.24	24.91	40.00	15.09	100	346	Vertical
2	95.9666	19.85	28.50	43.50	15.00	100	159	Vertical
3	213.0573	20.82	31.47	43.50	12.03	100	346	Vertical
4	240.0260	22.04	31.99	46.00	14.01	200	67	Vertical
5	598.1858	30.76	35.73	46.00	10.27	100	234	Vertical
6	840.0310	33.25	40.26	46.00	5.74	100	2	Vertical

APPENDIX B – Radiated Emission Above 1GHz Test Data Test Report

Project Information			
Customer:		EUT:	Car Audio Navigation
Model:	M903AT-11T	SN:	
Mode:	DH5_2402	Voltage:	12V/10A
Environment:	25°C/58%	Engineer:	Roger
Remark:			
Test Standard:			

Start of Test: 2022-10-27 09:40:05

Test Graph

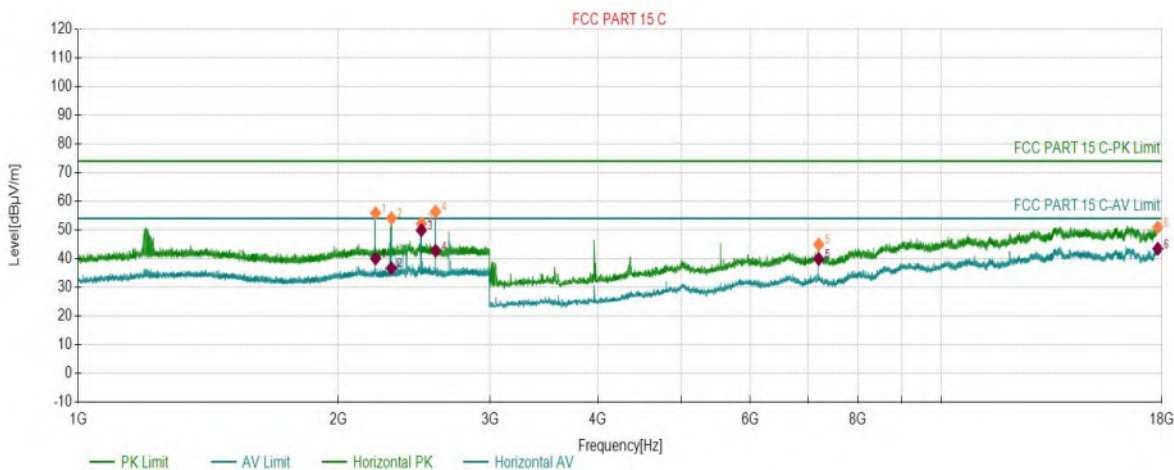

PK Final Data List								
NO.	Freq. (MHz)	Factor (dB)	PK Value (dBµV/m)	PK Limit (dBµV/m)	PK Margin (dB)	Height (cm)	Angle (°)	Polarity
1	2210.3210	6.01	55.84	74.00	18.16	150	293	Horizontal
2	2305.9306	6.17	54.07	74.00	19.93	150	285	Horizontal
3	2497.9498	7.21	52.20	74.00	21.80	150	334	Horizontal
4	2593.9594	7.17	56.35	74.00	17.65	150	47	Horizontal
5	7206.4206	-1.62	44.90	74.00	29.10	150	358	Horizontal
6	17800.4800	14.13	50.91	74.00	23.09	150	3	Horizontal

AV Final Data List								
NO.	Freq. (MHz)	Factor (dB)	AV Value (dBµV/m)	AV Limit (dBµV/m)	AV Margin (dB)	Height (cm)	Angle (°)	Polarity
1	2210.3210	6.01	40.01	54.00	13.99	150	293	Horizontal
2	2305.9306	6.17	36.66	54.00	17.34	150	285	Horizontal
3	2497.9498	7.21	49.89	54.00	4.11	150	334	Horizontal
4	2593.9594	7.17	42.73	54.00	11.27	150	47	Horizontal
5	7206.4206	-1.62	39.85	54.00	14.15	150	358	Horizontal
6	17800.4800	14.13	43.42	54.00	10.58	150	3	Horizontal

Test Report

Project Information			
Customer:		EUT:	Car Audio Navigation
Model:	M903AT-11T	SN:	
Mode:	DH5_2402	Voltage:	12V/10A
Environment:	25°C/58%	Engineer:	Roger
Remark:			
Test Standard:			

Start of Test: 2022-10-27 09:41:31

Test Graph

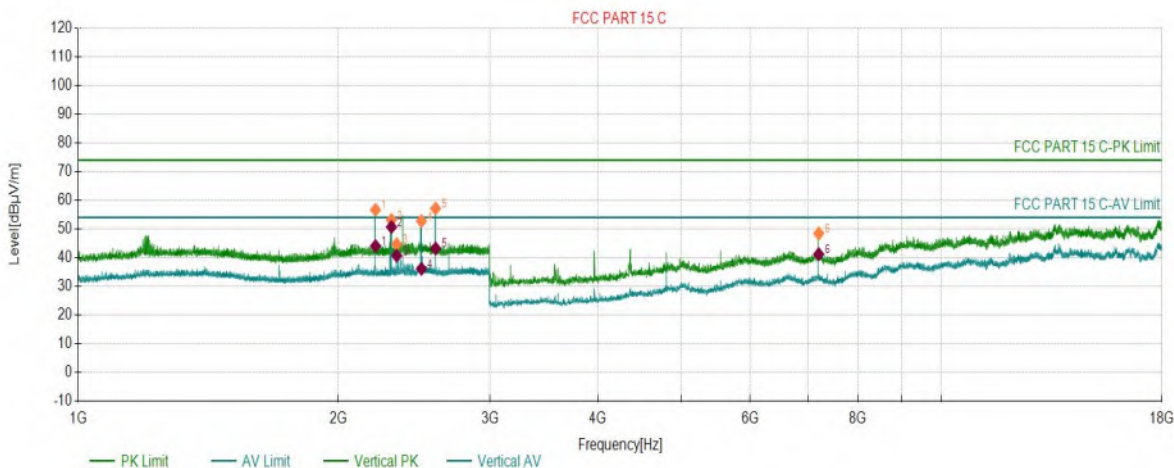

PK Final Data List								
NO.	Freq. (MHz)	Factor (dB)	PK Value (dBµV/m)	PK Limit (dBµV/m)	PK Margin (dB)	Height (cm)	Angle (°)	Polarity
1	2210.1210	6.01	56.67	74.00	17.33	150	110	Vertical
2	2306.1306	6.17	53.10	74.00	20.90	150	87	Vertical
3	2338.1338	6.35	44.66	74.00	29.34	150	324	Vertical
4	2497.9498	7.21	52.75	74.00	21.25	150	324	Vertical
5	2593.9594	7.17	57.11	74.00	16.89	150	324	Vertical
6	7206.4206	-1.62	48.40	74.00	25.60	150	9	Vertical

AV Final Data List								
NO.	Freq. (MHz)	Factor (dB)	AV Value (dBµV/m)	AV Limit (dBµV/m)	AV Margin (dB)	Height (cm)	Angle (°)	Polarity
1	2210.1210	6.01	44.01	54.00	9.99	150	110	Vertical
2	2306.1306	6.17	50.67	54.00	3.33	150	87	Vertical
3	2338.1338	6.35	40.66	54.00	13.34	150	324	Vertical
4	2497.9498	7.21	36.07	54.00	17.93	150	324	Vertical
5	2593.9594	7.17	43.17	54.00	10.83	150	324	Vertical
6	7206.4206	-1.62	41.16	54.00	12.84	150	9	Vertical

Test Report

Project Information			
Customer:		EUT:	Car Audio Navigation
Model:	M903AT-11T	SN:	
Mode:	DH5_2441	Voltage:	12V/10A
Environment:	25°C/58%	Engineer:	Roger
Remark:			
Test Standard:			

Start of Test: 2022-10-27 10:11:22

Test Graph

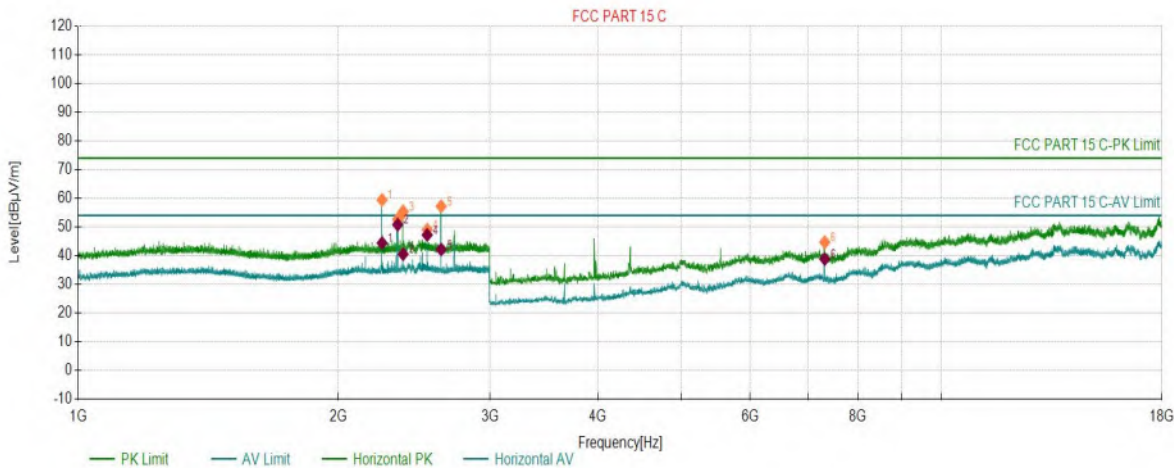

PK Final Data List								
NO.	Freq. (MHz)	Factor (dB)	PK Value (dBµV/m)	PK Limit (dBµV/m)	PK Margin (dB)	Height (cm)	Angle (°)	Polarity
1	2249.1249	6.07	59.43	74.00	14.57	150	283	Horizontal
2	2344.9345	6.39	52.63	74.00	21.37	150	314	Horizontal
3	2378.9379	6.53	55.37	74.00	18.63	150	277	Horizontal
4	2536.9537	7.65	49.04	74.00	24.96	150	130	Horizontal
5	2632.9633	7.21	57.18	74.00	16.82	150	265	Horizontal
6	7323.4323	-1.41	44.65	74.00	29.35	150	255	Horizontal

AV Final Data List								
NO.	Freq. (MHz)	Factor (dB)	AV Value (dBµV/m)	AV Limit (dBµV/m)	AV Margin (dB)	Height (cm)	Angle (°)	Polarity
1	2249.1249	6.07	44.37	54.00	9.63	150	283	Horizontal
2	2344.9345	6.39	50.78	54.00	3.22	150	314	Horizontal
3	2378.9379	6.53	40.48	54.00	13.52	150	277	Horizontal
4	2536.9537	7.65	47.20	54.00	6.80	150	130	Horizontal
5	2632.9633	7.21	42.11	54.00	11.89	150	265	Horizontal
6	7323.4323	-1.41	38.80	54.00	15.20	150	255	Horizontal

Test Report

Project Information			
Customer:		EUT:	Car Audio Navigation
Model:	M903AT-11T	SN:	
Mode:	DH5_2441	Voltage:	12V/10A
Environment:	25°C/58%	Engineer:	Roger
Remark:			
Test Standard:			

Start of Test: 2022-10-27 10:13:06

Test Graph

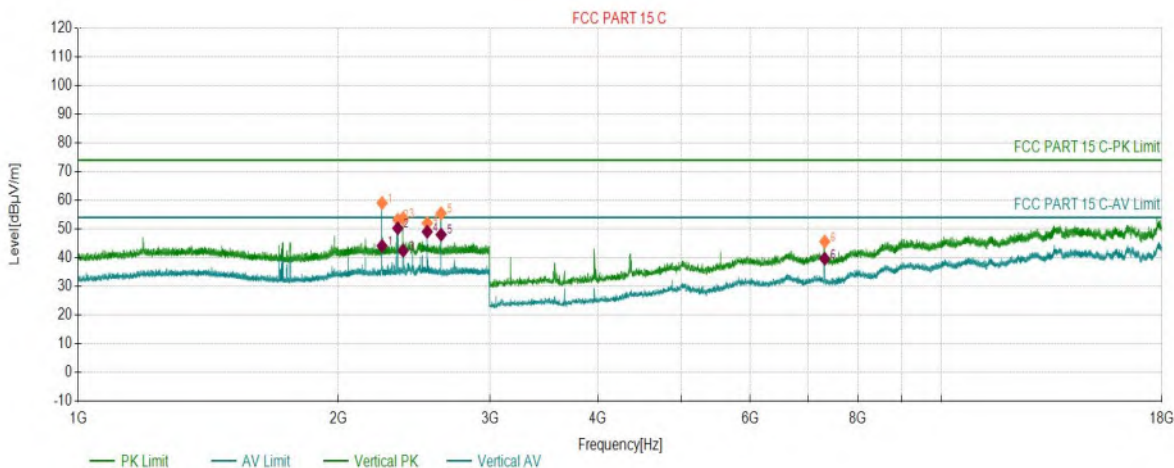

PK Final Data List								
NO.	Freq. (MHz)	Factor (dB)	PK Value (dBµV/m)	PK Limit (dBµV/m)	PK Margin (dB)	Height (cm)	Angle (°)	Polarity
1	2249.1249	6.07	59.02	74.00	14.98	150	101	Vertical
2	2345.1345	6.39	53.18	74.00	20.82	150	77	Vertical
3	2379.1379	6.53	53.71	74.00	20.29	150	258	Vertical
4	2536.9537	7.65	52.05	74.00	21.95	150	314	Vertical
5	2632.9633	7.21	55.42	74.00	18.58	150	308	Vertical
6	7323.4323	-1.41	45.55	74.00	28.45	150	246	Vertical

AV Final Data List								
NO.	Freq. (MHz)	Factor (dB)	AV Value (dBµV/m)	AV Limit (dBµV/m)	AV Margin (dB)	Height (cm)	Angle (°)	Polarity
1	2249.1249	6.07	44.07	54.00	9.93	150	101	Vertical
2	2345.1345	6.39	50.21	54.00	3.79	150	77	Vertical
3	2379.1379	6.53	42.38	54.00	11.62	150	258	Vertical
4	2536.9537	7.65	49.00	54.00	5.00	150	314	Vertical
5	2632.9633	7.21	47.99	54.00	6.01	150	308	Vertical
6	7323.4323	-1.41	39.59	54.00	14.41	150	246	Vertical

Test Report

Project Information			
Customer:		EUT:	Car Audio Navigation
Model:	M903AT-11T	SN:	
Mode:	DH5_2480	Voltage:	12V/10A
Environment:	25°C/58%	Engineer:	Roger
Remark:			
Test Standard:			

Start of Test: 2022-10-27 10:20:02

Test Graph

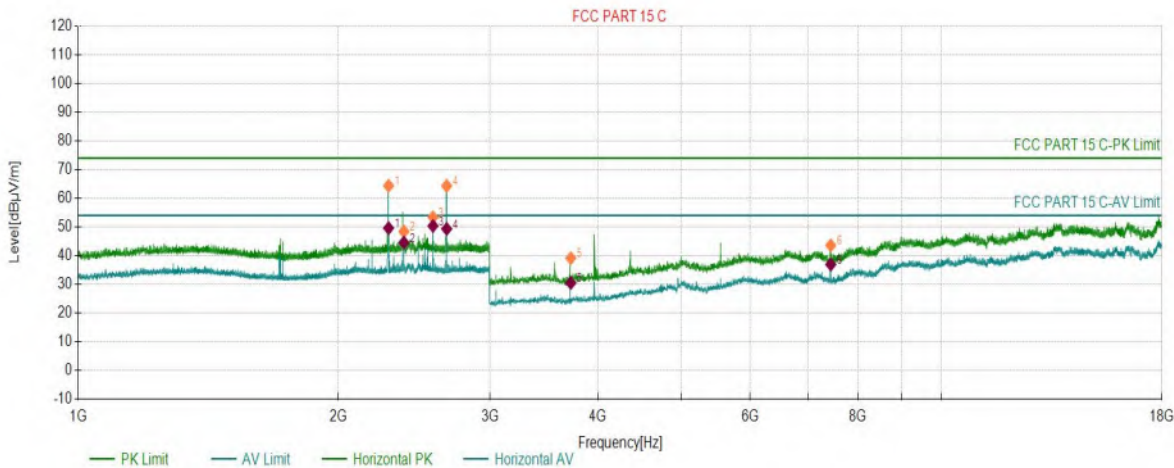

PK Final Data List								
NO.	Freq. (MHz)	Factor (dB)	PK Value (dBµV/m)	PK Limit (dBµV/m)	PK Margin (dB)	Height (cm)	Angle (°)	Polarity
1	2288.1288	6.12	64.35	74.00	9.65	150	244	Horizontal
2	2383.9384	6.62	48.38	74.00	25.62	150	268	Horizontal
3	2576.1576	7.32	53.37	74.00	20.63	150	30	Horizontal
4	2671.9672	7.32	64.32	74.00	9.68	150	230	Horizontal
5	3720.0720	-14.56	39.10	74.00	34.90	150	246	Horizontal
6	7440.4440	-1.68	43.56	74.00	30.44	150	113	Horizontal

AV Final Data List								
NO.	Freq. (MHz)	Factor (dB)	AV Value (dBµV/m)	AV Limit (dBµV/m)	AV Margin (dB)	Height (cm)	Angle (°)	Polarity
1	2288.1288	6.12	49.57	54.00	4.43	150	244	Horizontal
2	2383.9384	6.62	44.52	54.00	9.48	150	268	Horizontal
3	2576.1576	7.32	50.33	54.00	3.67	150	30	Horizontal
4	2671.9672	7.32	49.32	54.00	4.68	150	230	Horizontal
5	3720.0720	-14.56	30.45	54.00	23.55	150	246	Horizontal
6	7440.4440	-1.68	36.89	54.00	17.11	150	113	Horizontal

Test Report

Project Information			
Customer:		EUT:	Car Audio Navigation
Model:	M903AT-11T	SN:	
Mode:	DH5_2480	Voltage:	12V/10A
Environment:	25°C/58%	Engineer:	Roger
Remark:			
Test Standard:			

Start of Test: 2022-10-27 10:21:46

Test Graph

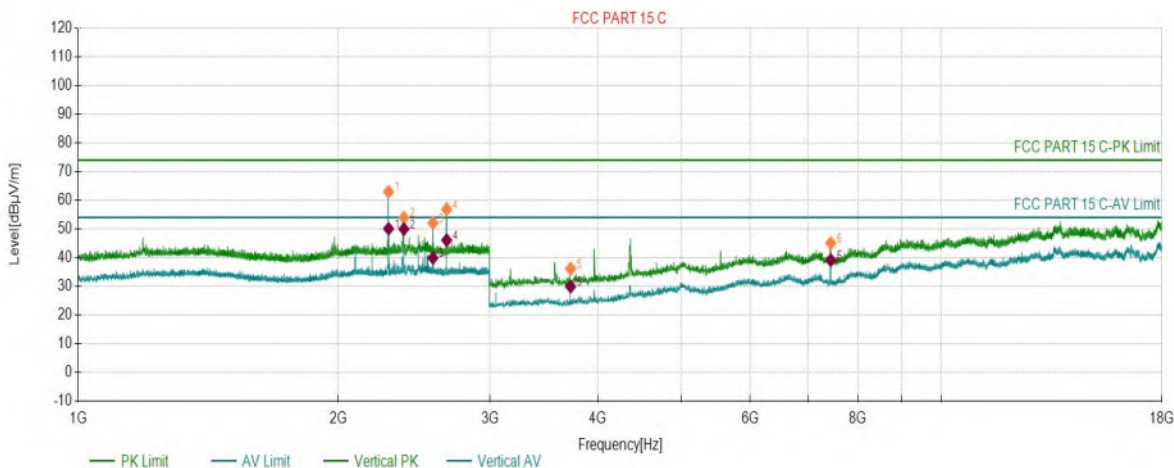

PK Final Data List

NO.	Freq. (MHz)	Factor (dB)	PK Value (dBµV/m)	PK Limit (dBµV/m)	PK Margin (dB)	Height (cm)	Angle (°)	Polarity
1	2288.3288	6.12	62.98	74.00	11.02	150	326	Vertical
2	2383.9384	6.62	53.92	74.00	20.08	150	314	Vertical
3	2575.9576	7.32	52.11	74.00	21.89	150	247	Vertical
4	2671.9672	7.32	56.82	74.00	17.18	150	152	Vertical
5	3718.5719	-14.57	36.16	74.00	37.84	150	310	Vertical
6	7440.4440	-1.68	45.07	74.00	28.93	150	316	Vertical

AV Final Data List

NO.	Freq. (MHz)	Factor (dB)	AV Value (dBµV/m)	AV Limit (dBµV/m)	AV Margin (dB)	Height (cm)	Angle (°)	Polarity
1	2288.3288	6.12	50.05	54.00	3.95	150	326	Vertical
2	2383.9384	6.62	49.92	54.00	4.08	150	314	Vertical
3	2575.9576	7.32	39.88	54.00	14.12	150	247	Vertical
4	2671.9672	7.32	46.08	54.00	7.92	150	152	Vertical
5	3718.5719	-14.57	29.87	54.00	24.13	150	310	Vertical
6	7440.4440	-1.68	39.10	54.00	14.90	150	316	Vertical

Test Report

Project Information			
Customer:		EUT:	Car Audio Navigation
Model:	M903AT-11T	SN:	
Mode:	2DH5_2402	Voltage:	12V/10A
Environment:	25°C/58%	Engineer:	Roger
Remark:			
Test Standard:			

Start of Test: 2022-10-27 10:53:29

Test Graph



PK Final Data List

NO.	Freq. (MHz)	Factor (dB)	PK Value (dBµV/m)	PK Limit (dBµV/m)	PK Margin (dB)	Height (cm)	Angle (°)	Polarity
1	2210.3210	6.01	54.58	74.00	19.42	150	285	Horizontal
2	2306.3306	6.18	52.32	74.00	21.68	150	272	Horizontal
3	2498.3498	7.26	50.15	74.00	23.85	150	241	Horizontal
4	2593.7594	7.17	58.19	74.00	15.81	150	266	Horizontal
5	3964.5965	-13.37	36.10	74.00	37.90	150	249	Horizontal
6	17815.4815	14.24	52.09	74.00	21.91	150	262	Horizontal

AV Final Data List

NO.	Freq. (MHz)	Factor (dB)	AV Value (dBµV/m)	AV Limit (dBµV/m)	AV Margin (dB)	Height (cm)	Angle (°)	Polarity
1	2210.3210	6.01	41.66	54.00	12.34	150	285	Horizontal
2	2306.3306	6.18	48.90	54.00	5.10	150	272	Horizontal
3	2498.3498	7.26	46.66	54.00	7.34	150	241	Horizontal
4	2593.7594	7.17	43.98	54.00	10.02	150	266	Horizontal
5	3964.5965	-13.37	30.59	54.00	23.41	150	249	Horizontal
6	17815.4815	14.24	43.59	54.00	10.41	150	262	Horizontal

Test Report

Project Information			
Customer:		EUT:	Car Audio Navigation
Model:	M903AT-11T	SN:	
Mode:	2DH5_2402	Voltage:	12V/10A
Environment:	25°C/58%	Engineer:	Roger
Remark:			
Test Standard:			

Start of Test: 2022-10-27 10:55:14

Test Graph

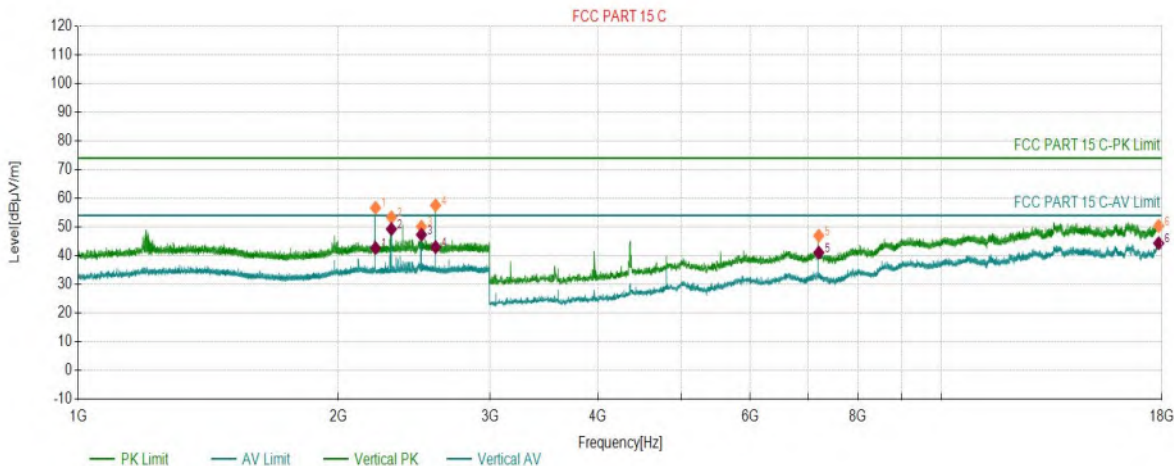

PK Final Data List								
NO.	Freq. (MHz)	Factor (dB)	PK Value (dBµV/m)	PK Limit (dBµV/m)	PK Margin (dB)	Height (cm)	Angle (°)	Polarity
1	2209.9210	6.01	56.64	74.00	17.36	150	110	Vertical
2	2306.1306	6.17	53.37	74.00	20.63	150	68	Vertical
3	2497.9498	7.21	50.07	74.00	23.93	150	313	Vertical
4	2594.1594	7.17	57.53	74.00	16.47	150	266	Vertical
5	7206.4206	-1.62	46.93	74.00	27.07	150	338	Vertical
6	17839.4839	14.41	50.35	74.00	23.65	150	196	Vertical

AV Final Data List								
NO.	Freq. (MHz)	Factor (dB)	AV Value (dBµV/m)	AV Limit (dBµV/m)	AV Margin (dB)	Height (cm)	Angle (°)	Polarity
1	2209.9210	6.01	42.63	54.00	11.37	150	110	Vertical
2	2306.1306	6.17	49.23	54.00	4.77	150	68	Vertical
3	2497.9498	7.21	47.29	54.00	6.71	150	313	Vertical
4	2594.1594	7.17	42.95	54.00	11.05	150	266	Vertical
5	7206.4206	-1.62	41.02	54.00	12.98	150	338	Vertical
6	17839.4839	14.41	44.31	54.00	9.69	150	196	Vertical

Test Report

Project Information			
Customer:		EUT:	Car Audio Navigation
Model:	M903AT-11T	SN:	
Mode:	2DH5_2441	Voltage:	12V/10A
Environment:	25°C/58%	Engineer:	Roger
Remark:			
Test Standard:			

Start of Test: 2022-10-27 11:14:50

Test Graph

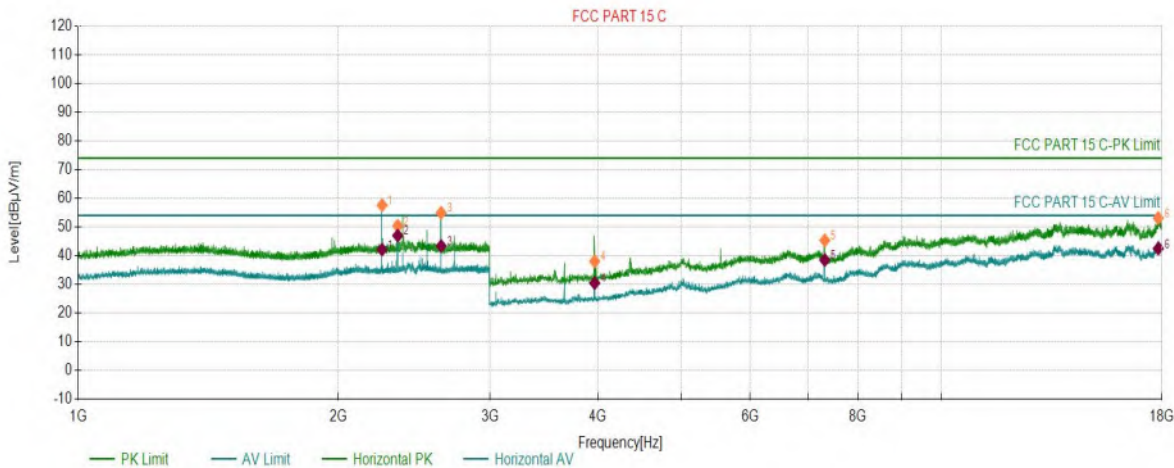

PK Final Data List								
NO.	Freq. (MHz)	Factor (dB)	PK Value (dBµV/m)	PK Limit (dBµV/m)	PK Margin (dB)	Height (cm)	Angle (°)	Polarity
1	2249.1249	6.07	57.56	74.00	16.44	150	284	Horizontal
2	2344.9345	6.39	50.37	74.00	23.63	150	308	Horizontal
3	2632.9633	7.21	54.90	74.00	19.10	150	271	Horizontal
4	3964.5965	-13.37	37.99	74.00	36.01	150	257	Horizontal
5	7323.4323	-1.41	45.29	74.00	28.71	150	100	Horizontal
6	17819.9820	14.27	53.06	74.00	20.94	150	162	Horizontal

AV Final Data List								
NO.	Freq. (MHz)	Factor (dB)	AV Value (dBµV/m)	AV Limit (dBµV/m)	AV Margin (dB)	Height (cm)	Angle (°)	Polarity
1	2249.1249	6.07	42.09	54.00	11.91	150	284	Horizontal
2	2344.9345	6.39	46.97	54.00	7.03	150	308	Horizontal
3	2632.9633	7.21	43.35	54.00	10.65	150	271	Horizontal
4	3964.5965	-13.37	30.40	54.00	23.60	150	257	Horizontal
5	7323.4323	-1.41	38.42	54.00	15.58	150	100	Horizontal
6	17819.9820	14.27	42.46	54.00	11.54	150	162	Horizontal

Test Report

Project Information			
Customer:		EUT:	Car Audio Navigation
Model:	M903AT-11T	SN:	
Mode:	2DH5_2441	Voltage:	12V/10A
Environment:	25°C/58%	Engineer:	Roger
Remark:			
Test Standard:			

Start of Test: 2022-10-27 11:16:33

Test Graph

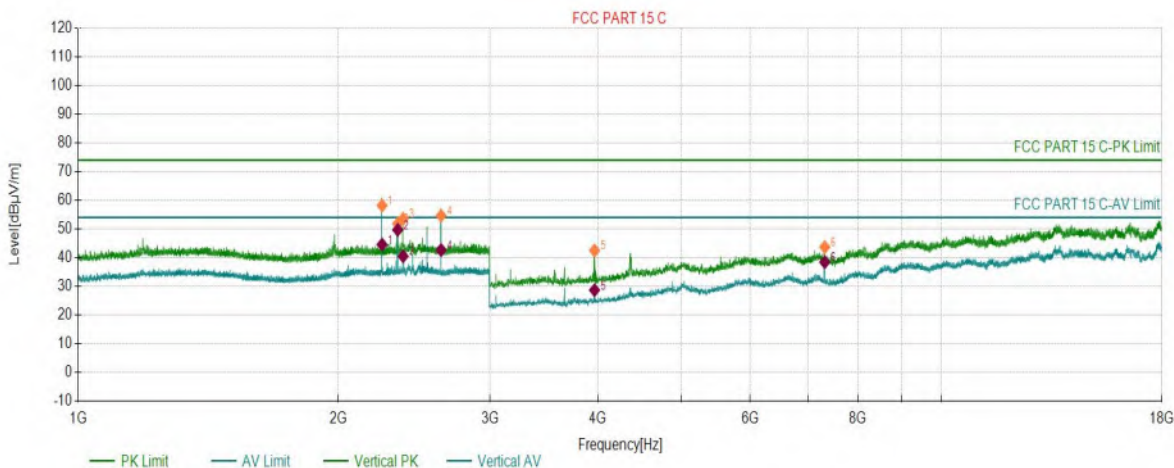

PK Final Data List								
NO.	Freq. (MHz)	Factor (dB)	PK Value (dBµV/m)	PK Limit (dBµV/m)	PK Margin (dB)	Height (cm)	Angle (°)	Polarity
1	2249.1249	6.07	58.16	74.00	15.84	150	173	Vertical
2	2344.9345	6.39	51.84	74.00	22.16	150	266	Vertical
3	2378.7379	6.52	53.52	74.00	20.48	150	6	Vertical
4	2632.5633	7.21	54.63	74.00	19.37	150	302	Vertical
5	3963.0963	-13.38	42.47	74.00	31.53	150	85	Vertical
6	7323.4323	-1.41	43.66	74.00	30.34	150	269	Vertical

AV Final Data List								
NO.	Freq. (MHz)	Factor (dB)	AV Value (dBµV/m)	AV Limit (dBµV/m)	AV Margin (dB)	Height (cm)	Angle (°)	Polarity
1	2249.1249	6.07	44.52	54.00	9.48	150	173	Vertical
2	2344.9345	6.39	49.65	54.00	4.35	150	266	Vertical
3	2378.7379	6.52	40.45	54.00	13.55	150	6	Vertical
4	2632.5633	7.21	42.63	54.00	11.37	150	302	Vertical
5	3963.0963	-13.38	28.64	54.00	25.36	150	85	Vertical
6	7323.4323	-1.41	38.38	54.00	15.62	150	269	Vertical

Test Report

Project Information			
Customer:		EUT:	Car Audio Navigation
Model:	M903AT-11T	SN:	
Mode:	2DH5_2480	Voltage:	12V/10A
Environment:	25°C/58%	Engineer:	Roger
Remark:			
Test Standard:			

Start of Test: 2022-10-27 11:26:08

Test Graph

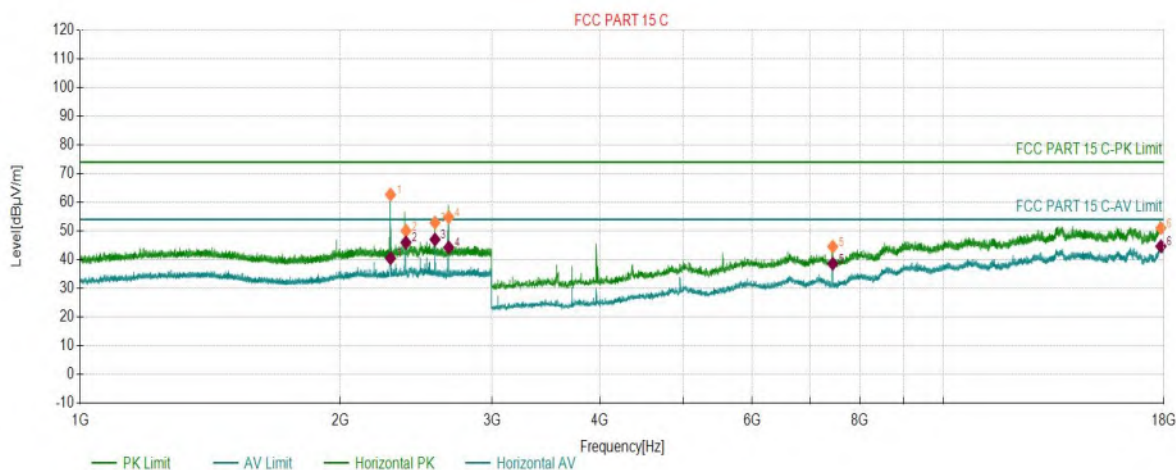

PK Final Data List								
NO.	Freq. (MHz)	Factor (dB)	PK Value (dBµV/m)	PK Limit (dBµV/m)	PK Margin (dB)	Height (cm)	Angle (°)	Polarity
1	2288.1288	6.12	62.66	74.00	11.34	150	246	Horizontal
2	2384.3384	6.62	50.04	74.00	23.96	150	114	Horizontal
3	2576.1576	7.32	52.88	74.00	21.12	150	267	Horizontal
4	2672.5673	7.32	54.76	74.00	19.24	150	239	Horizontal
5	7440.4440	-1.68	44.51	74.00	29.49	150	242	Horizontal
6	17851.4851	14.50	50.99	74.00	23.01	150	52	Horizontal

AV Final Data List								
NO.	Freq. (MHz)	Factor (dB)	AV Value (dBµV/m)	AV Limit (dBµV/m)	AV Margin (dB)	Height (cm)	Angle (°)	Polarity
1	2288.1288	6.12	40.44	54.00	13.56	150	246	Horizontal
2	2384.3384	6.62	45.93	54.00	8.07	150	114	Horizontal
3	2576.1576	7.32	46.99	54.00	7.01	150	267	Horizontal
4	2672.5673	7.32	44.24	54.00	9.76	150	239	Horizontal
5	7440.4440	-1.68	38.54	54.00	15.46	150	242	Horizontal
6	17851.4851	14.50	44.64	54.00	9.36	150	52	Horizontal

Test Report

Project Information			
Customer:		EUT:	Car Audio Navigation
Model:	M903AT-11T	SN:	
Mode:	2DH5_2480	Voltage:	12V/10A
Environment:	25°C/58%	Engineer:	Roger
Remark:			
Test Standard:			

Start of Test: 2022-10-27 11:27:53

Test Graph

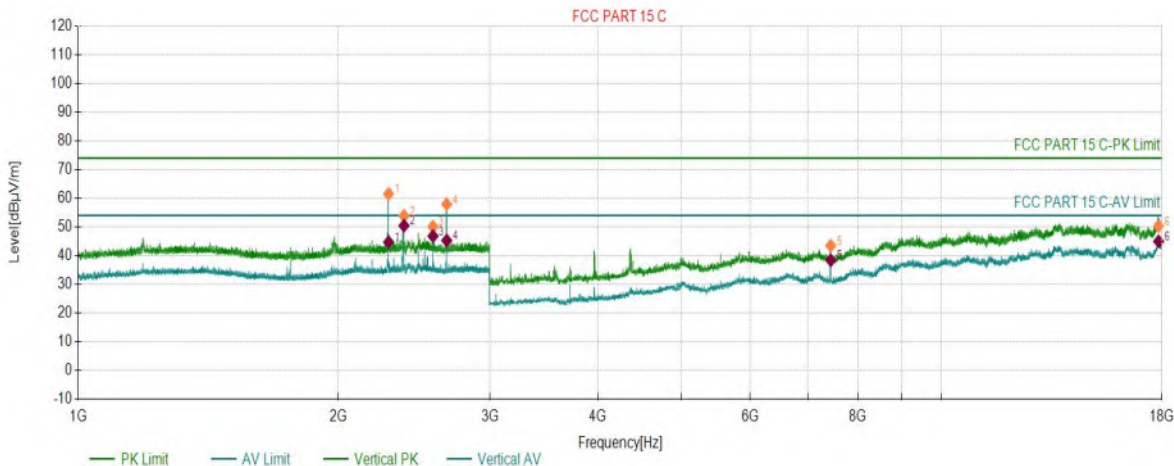

PK Final Data List								
NO.	Freq. (MHz)	Factor (dB)	PK Value (dBµV/m)	PK Limit (dBµV/m)	PK Margin (dB)	Height (cm)	Angle (°)	Polarity
1	2288.3288	6.12	61.50	74.00	12.50	150	83	Vertical
2	2384.3384	6.62	53.85	74.00	20.15	150	314	Vertical
3	2576.1576	7.32	50.09	74.00	23.91	150	245	Vertical
4	2672.1672	7.32	57.90	74.00	16.10	150	302	Vertical
5	7440.4440	-1.68	43.44	74.00	30.56	150	262	Vertical
6	17833.4833	14.37	50.32	74.00	23.68	150	219	Vertical

AV Final Data List								
NO.	Freq. (MHz)	Factor (dB)	AV Value (dBµV/m)	AV Limit (dBµV/m)	AV Margin (dB)	Height (cm)	Angle (°)	Polarity
1	2288.3288	6.12	44.68	54.00	9.32	150	83	Vertical
2	2384.3384	6.62	50.42	54.00	3.58	150	314	Vertical
3	2576.1576	7.32	46.79	54.00	7.21	150	245	Vertical
4	2672.1672	7.32	45.27	54.00	8.73	150	302	Vertical
5	7440.4440	-1.68	38.39	54.00	15.61	150	262	Vertical
6	17833.4833	14.37	44.95	54.00	9.05	150	219	Vertical

Test Report

Project Information			
Customer:		EUT:	Car Audio Navigation
Model:	M903AT-11T	SN:	
Mode:	3DH5_2402	Voltage:	12V/10A
Environment:	25°C/58%	Engineer:	Roger
Remark:			
Test Standard:			

Start of Test: 2022-10-27 11:37:53

Test Graph

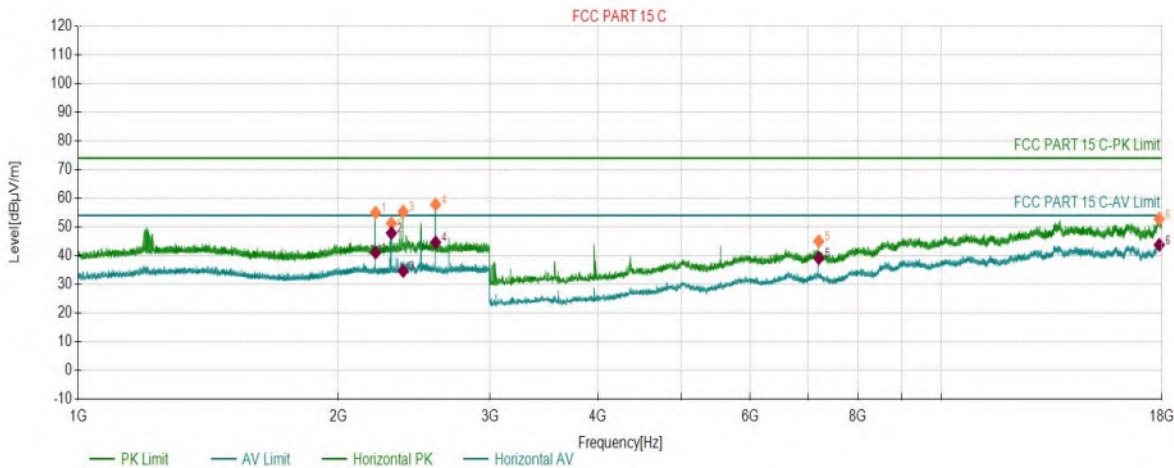

PK Final Data List								
NO.	Freq. (MHz)	Factor (dB)	PK Value (dBµV/m)	PK Limit (dBµV/m)	PK Margin (dB)	Height (cm)	Angle (°)	Polarity
1	2210.3210	6.01	54.93	74.00	19.07	150	274	Horizontal
2	2305.9306	6.17	51.21	74.00	22.79	150	250	Horizontal
3	2379.1379	6.53	55.35	74.00	18.65	150	294	Horizontal
4	2594.1594	7.17	57.80	74.00	16.20	150	57	Horizontal
5	7206.4206	-1.62	44.97	74.00	29.03	150	320	Horizontal
6	17866.4866	14.61	52.80	74.00	21.20	150	110	Horizontal

AV Final Data List								
NO.	Freq. (MHz)	Factor (dB)	AV Value (dBµV/m)	AV Limit (dBµV/m)	AV Margin (dB)	Height (cm)	Angle (°)	Polarity
1	2210.3210	6.01	41.04	54.00	12.96	150	274	Horizontal
2	2305.9306	6.17	47.85	54.00	6.15	150	250	Horizontal
3	2379.1379	6.53	34.60	54.00	19.40	150	294	Horizontal
4	2594.1594	7.17	44.60	54.00	9.40	150	57	Horizontal
5	7206.4206	-1.62	39.08	54.00	14.92	150	320	Horizontal
6	17866.4866	14.61	43.71	54.00	10.29	150	110	Horizontal

Test Report

Project Information			
Customer:		EUT:	Car Audio Navigation
Model:	M903AT-11T	SN:	
Mode:	3DH5_2402	Voltage:	12V/10A
Environment:	25°C/58%	Engineer:	Roger
Remark:			
Test Standard:			

Start of Test: 2022-10-27 11:39:36

Test Graph

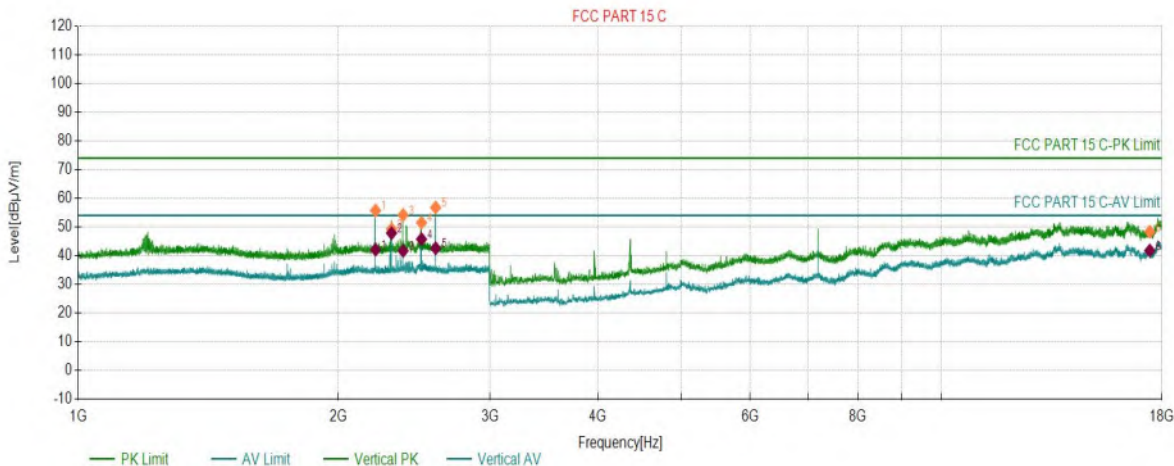

PK Final Data List

NO.	Freq. (MHz)	Factor (dB)	PK Value (dBµV/m)	PK Limit (dBµV/m)	PK Margin (dB)	Height (cm)	Angle (°)	Polarity
1	2210.3210	6.01	55.72	74.00	18.28	150	188	Vertical
2	2306.7307	6.18	49.22	74.00	24.78	150	324	Vertical
3	2378.9379	6.53	54.18	74.00	19.82	150	268	Vertical
4	2498.3498	7.26	51.49	74.00	22.51	150	233	Vertical
5	2594.3594	7.17	56.75	74.00	17.25	150	268	Vertical
6	17422.4422	10.94	48.31	74.00	25.69	150	183	Vertical

AV Final Data List

NO.	Freq. (MHz)	Factor (dB)	AV Value (dBµV/m)	AV Limit (dBµV/m)	AV Margin (dB)	Height (cm)	Angle (°)	Polarity
1	2210.3210	6.01	42.07	54.00	11.93	150	188	Vertical
2	2306.7307	6.18	47.81	54.00	6.19	150	324	Vertical
3	2378.9379	6.53	41.65	54.00	12.35	150	268	Vertical
4	2498.3498	7.26	45.70	54.00	8.30	150	233	Vertical
5	2594.3594	7.17	42.54	54.00	11.46	150	268	Vertical
6	17422.4422	10.94	41.74	54.00	12.26	150	183	Vertical

Test Report

Project Information			
Customer:		EUT:	Car Audio Navigation
Model:	M903AT-11T	SN:	
Mode:	3DH5_2441	Voltage:	12V/10A
Environment:	25°C/58%	Engineer:	Roger
Remark:			
Test Standard:			

Start of Test: 2022-10-27 11:44:24

Test Graph

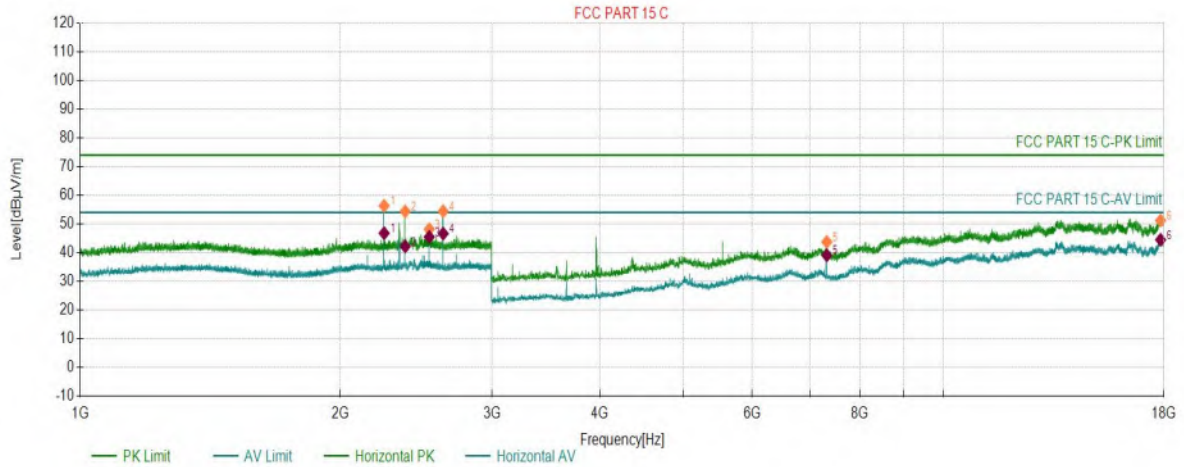

PK Final Data List								
NO.	Freq. (MHz)	Factor (dB)	PK Value (dBµV/m)	PK Limit (dBµV/m)	PK Margin (dB)	Height (cm)	Angle (°)	Polarity
1	2249.3249	6.07	56.29	74.00	17.71	150	248	Horizontal
2	2379.3379	6.53	54.36	74.00	19.64	150	280	Horizontal
3	2536.9537	7.65	48.14	74.00	25.86	150	321	Horizontal
4	2632.9633	7.21	54.42	74.00	19.58	150	274	Horizontal
5	7323.4323	-1.41	43.71	74.00	30.29	150	246	Horizontal
6	17834.9835	14.38	51.21	74.00	22.79	150	156	Horizontal

AV Final Data List								
NO.	Freq. (MHz)	Factor (dB)	AV Value (dBµV/m)	AV Limit (dBµV/m)	AV Margin (dB)	Height (cm)	Angle (°)	Polarity
1	2249.3249	6.07	46.75	54.00	7.25	150	248	Horizontal
2	2379.3379	6.53	42.12	54.00	11.88	150	280	Horizontal
3	2536.9537	7.65	45.46	54.00	8.54	150	321	Horizontal
4	2632.9633	7.21	46.61	54.00	7.39	150	274	Horizontal
5	7323.4323	-1.41	39.04	54.00	14.96	150	246	Horizontal
6	17834.9835	14.38	44.47	54.00	9.53	150	156	Horizontal

Test Report

Project Information			
Customer:		EUT:	Car Audio Navigation
Model:	M903AT-11T	SN:	
Mode:	3DH5_2441	Voltage:	12V/10A
Environment:	25°C/58%	Engineer:	Roger
Remark:			
Test Standard:			

Start of Test: 2022-10-27 11:46:08

Test Graph

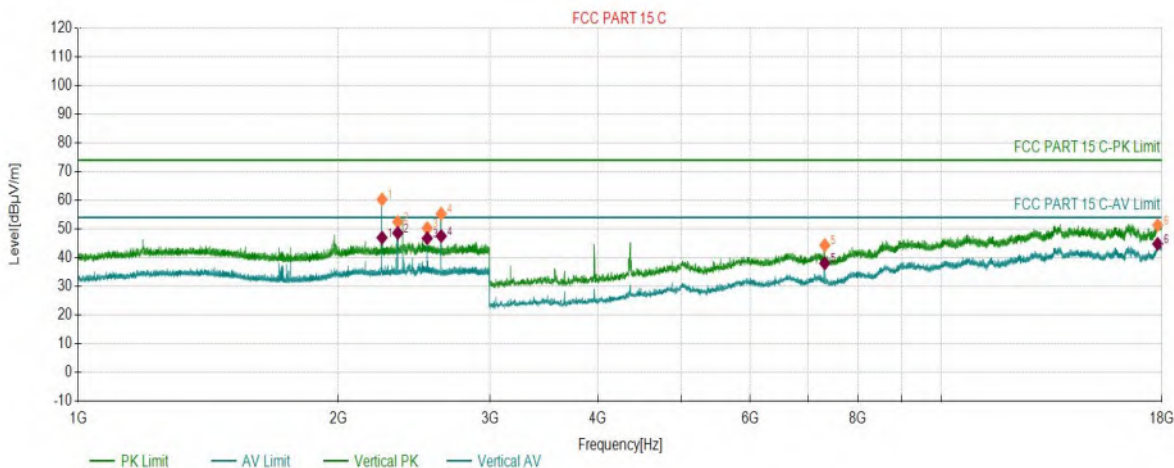

PK Final Data List

NO.	Freq. (MHz)	Factor (dB)	PK Value (dBµV/m)	PK Limit (dBµV/m)	PK Margin (dB)	Height (cm)	Angle (°)	Polarity
1	2248.9249	6.07	60.27	74.00	13.73	150	273	Vertical
2	2345.1345	6.39	52.41	74.00	21.59	150	317	Vertical
3	2536.9537	7.65	50.25	74.00	23.75	150	163	Vertical
4	2633.1633	7.21	55.24	74.00	18.76	150	169	Vertical
5	7323.4323	-1.41	44.31	74.00	29.69	150	307	Vertical
6	17792.9793	14.05	51.32	74.00	22.68	150	163	Vertical

AV Final Data List

NO.	Freq. (MHz)	Factor (dB)	AV Value (dBµV/m)	AV Limit (dBµV/m)	AV Margin (dB)	Height (cm)	Angle (°)	Polarity
1	2248.9249	6.07	46.95	54.00	7.05	150	273	Vertical
2	2345.1345	6.39	48.56	54.00	5.44	150	317	Vertical
3	2536.9537	7.65	46.72	54.00	7.28	150	163	Vertical
4	2633.1633	7.21	47.50	54.00	6.50	150	169	Vertical
5	7323.4323	-1.41	37.99	54.00	16.01	150	307	Vertical
6	17792.9793	14.05	44.77	54.00	9.23	150	163	Vertical

Test Report

Project Information			
Customer:		EUT:	Car Audio Navigation
Model:	M903AT-11T	SN:	
Mode:	3DH5_2480	Voltage:	12V/10A
Environment:	25°C/58%	Engineer:	Roger
Remark:			
Test Standard:			

Start of Test: 2022-10-27 11:53:26

Test Graph

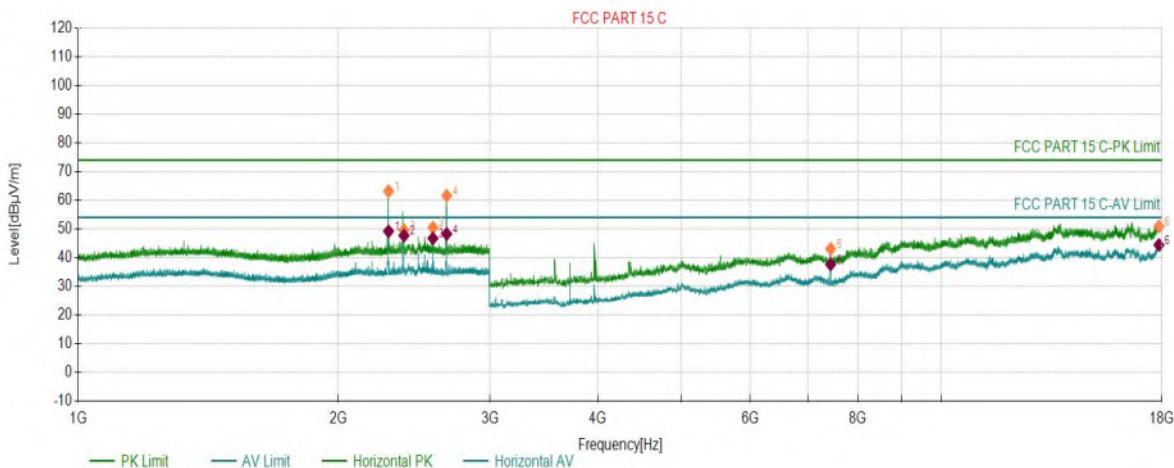

PK Final Data List								
NO.	Freq. (MHz)	Factor (dB)	PK Value (dBµV/m)	PK Limit (dBµV/m)	PK Margin (dB)	Height (cm)	Angle (°)	Polarity
1	2288.3288	6.12	63.16	74.00	10.84	150	320	Horizontal
2	2384.1384	6.62	49.60	74.00	24.40	150	121	Horizontal
3	2575.7576	7.32	50.48	74.00	23.52	150	239	Horizontal
4	2671.9672	7.32	61.58	74.00	12.42	150	232	Horizontal
5	7438.9439	-1.69	43.03	74.00	30.97	150	231	Horizontal
6	17849.9850	14.49	50.88	74.00	23.12	150	284	Horizontal

AV Final Data List								
NO.	Freq. (MHz)	Factor (dB)	AV Value (dBµV/m)	AV Limit (dBµV/m)	AV Margin (dB)	Height (cm)	Angle (°)	Polarity
1	2288.3288	6.12	49.18	54.00	4.82	150	320	Horizontal
2	2384.1384	6.62	47.68	54.00	6.32	150	121	Horizontal
3	2575.7576	7.32	46.68	54.00	7.32	150	239	Horizontal
4	2671.9672	7.32	48.24	54.00	5.76	150	232	Horizontal
5	7438.9439	-1.69	37.62	54.00	16.38	150	231	Horizontal
6	17849.9850	14.49	44.40	54.00	9.60	150	284	Horizontal

Test Report

Project Information			
Customer:		EUT:	Car Audio Navigation
Model:	M903AT-11T	SN:	
Mode:	3DH5_2480	Voltage:	12V/10A
Environment:	25°C/58%	Engineer:	Roger
Remark:			
Test Standard:			

Start of Test: 2022-10-27 11:55:09

Test Graph

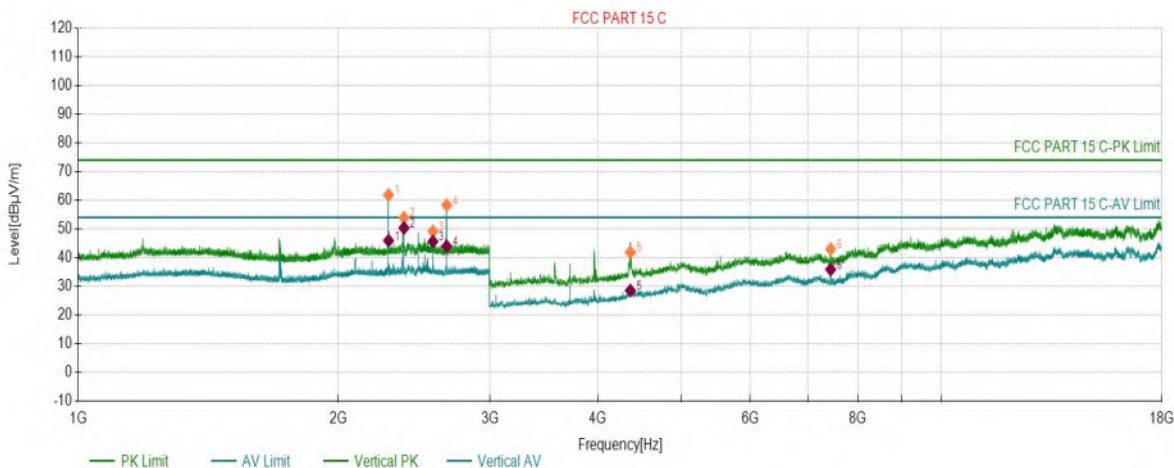

PK Final Data List								
NO.	Freq. (MHz)	Factor (dB)	PK Value (dBµV/m)	PK Limit (dBµV/m)	PK Margin (dB)	Height (cm)	Angle (°)	Polarity
1	2288.3288	6.12	61.83	74.00	12.17	150	321	Vertical
2	2384.1384	6.62	53.88	74.00	20.12	150	328	Vertical
3	2575.7576	7.32	49.19	74.00	24.81	150	251	Vertical
4	2671.7672	7.32	58.28	74.00	15.72	150	157	Vertical
5	4360.6361	-11.67	41.83	74.00	32.17	150	332	Vertical
6	7438.9439	-1.69	42.94	74.00	31.06	150	294	Vertical

AV Final Data List								
NO.	Freq. (MHz)	Factor (dB)	AV Value (dBµV/m)	AV Limit (dBµV/m)	AV Margin (dB)	Height (cm)	Angle (°)	Polarity
1	2288.3288	6.12	45.91	54.00	8.09	150	321	Vertical
2	2384.1384	6.62	50.34	54.00	3.66	150	328	Vertical
3	2575.7576	7.32	45.61	54.00	8.39	150	251	Vertical
4	2671.7672	7.32	43.91	54.00	10.09	150	157	Vertical
5	4360.6361	-11.67	28.47	54.00	25.53	150	332	Vertical
6	7438.9439	-1.69	35.85	54.00	18.15	150	294	Vertical

Restriction Band Emission

Test Report

Project Information			
Customer:		EUT:	Car Audio Navigation
Model:	M903AT-11T	SN:	
Mode:	DH5_2402	Voltage:	12V/10A
Environment:	25°C/58%	Engineer:	Roger
Remark:			
Test Standard:			

Start of Test: 2022-10-26 16:45:47

Test Graph

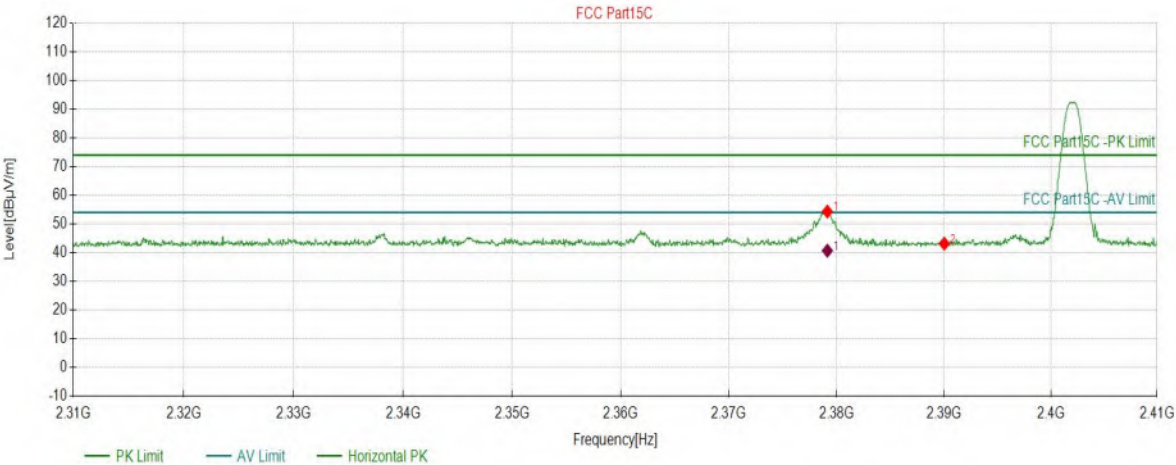

Suspected Data List									
NO.	Freq. (MHz)	Level (dBµV/m)	Factor (dB)	Limit (dBµV/m)	Margin (dB)	Height (cm)	Angle (°)	Detector	Polarity
1	2379.1346	54.29	6.44	74.00	19.71	150	279	PK	Horizontal
2	2390.0400	43.11	6.47	74.00	30.89	150	173	PK	Horizontal

AV Final Data List									
NO.	Freq. (MHz)	Factor (dB)	AV Value (dBµV/m)	AV Limit (dBµV/m)	AV Margin (dB)	Height (cm)	Angle (°)	Polarity	
1	2379.1346	6.44	40.65	54.00	13.35	150	279	Horizontal	

Test Report

Project Information			
Customer:		EUT:	Car Audio Navigation
Model:	M903AT-11T	SN:	
Mode:	DH5_2402	Voltage:	12V/10A
Environment:	25°C/58%	Engineer:	Roger
Remark:			
Test Standard:			

Start of Test: 2022-10-26 16:46:38

Test Graph

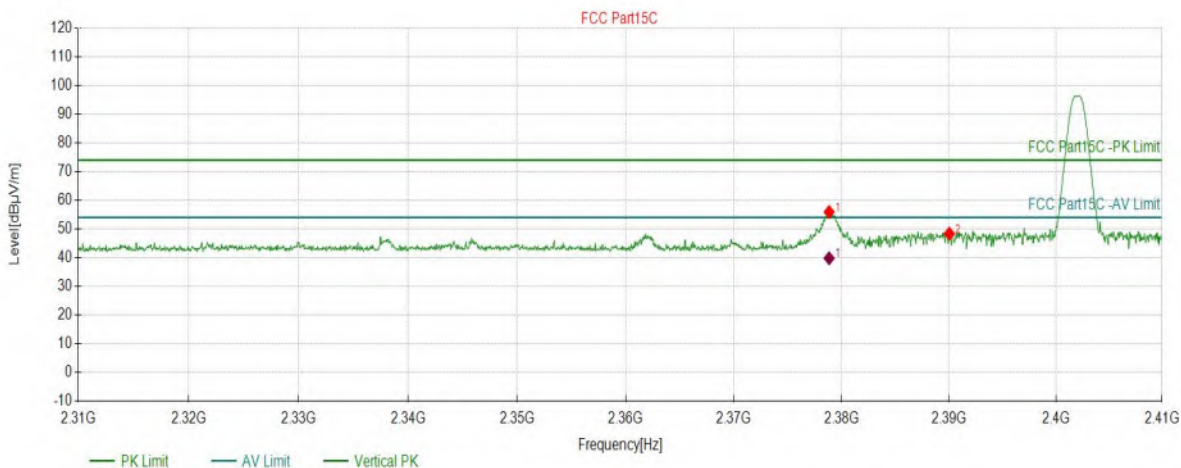

Suspected Data List

NO.	Freq. (MHz)	Level (dBµV/m)	Factor (dB)	Limit (dBµV/m)	Margin (dB)	Height (cm)	Angle (°)	Detector	Polarity
1	2378.8344	55.92	6.44	74.00	18.08	150	194	PK	Vertical
2	2390.0400	48.32	6.47	74.00	25.68	150	159	PK	Vertical

AV Final Data List

NO.	Freq. (MHz)	Factor (dB)	AV Value (dBµV/m)	AV Limit (dBµV/m)	AV Margin (dB)	Height (cm)	Angle (°)	Polarity
1	2378.8345	6.44	39.75	54.00	14.25	150	72.6	Vertical

Test Report

Project Information			
Customer:		EUT:	Car Audio Navigation
Model:	M903AT-11T	SN:	
Mode:	DH5_2480	Voltage:	12V/10A
Environment:	25°C/58%	Engineer:	Roger
Remark:			
Test Standard:			

Start of Test: 2022-10-27 10:47:08

Test Graph

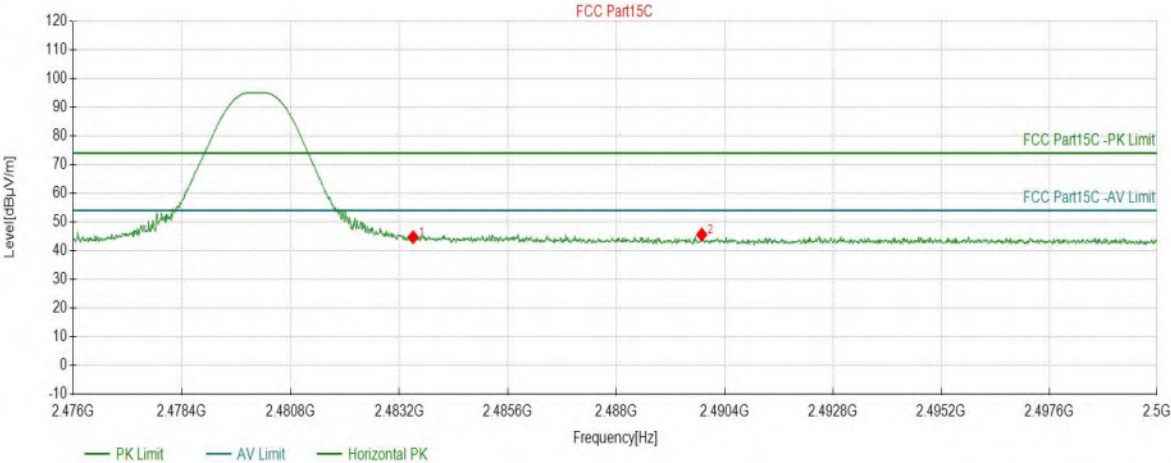

Suspected Data List									
NO.	Freq. (MHz)	Level (dBµV/m)	Factor (dB)	Limit (dBµV/m)	Margin (dB)	Height (cm)	Angle (°)	Detector	Polarity
1	2483.5038	44.67	7.09	74.00	29.33	150	286	PK	Horizontal
2	2489.8909	45.58	7.14	74.00	28.42	150	51	PK	Horizontal

Test Report

Project Information			
Customer:		EUT:	Car Audio Navigation
Model:	M903AT-11T	SN:	
Mode:	DH5_2480	Voltage:	12V/10A
Environment:	25°C/58%	Engineer:	Roger
Remark:			
Test Standard:			

Start of Test: 2022-10-27 10:48:07

Test Graph

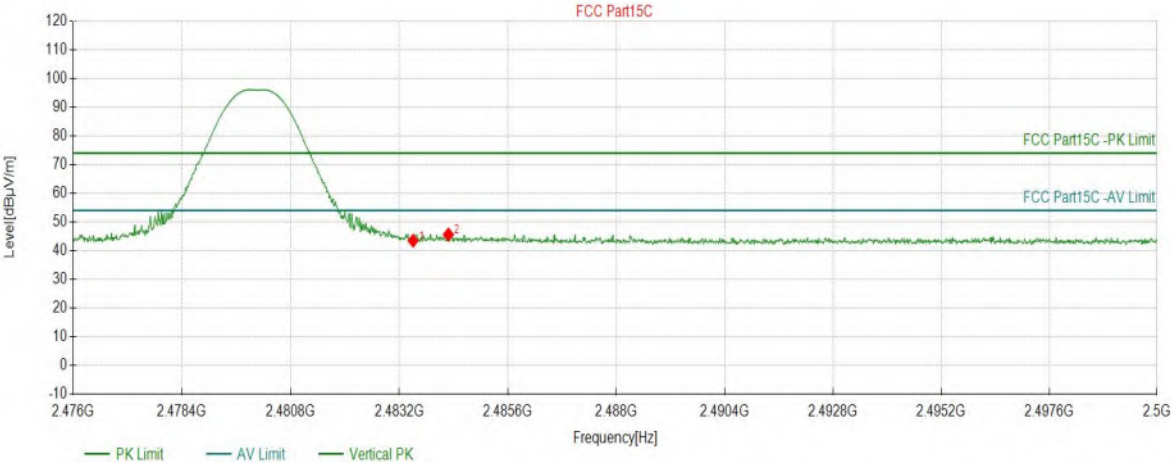

Suspected Data List									
NO.	Freq. (MHz)	Level (dBµV/m)	Factor (dB)	Limit (dBµV/m)	Margin (dB)	Height (cm)	Angle (°)	Detector	Polarity
1	2483.5038	43.46	7.09	74.00	30.54	150	61	PK	Vertical
2	2484.2841	45.58	7.10	74.00	28.42	150	319	PK	Vertical

Test Report

Project Information			
Customer:		EUT:	Car Audio Navigation
Model:	M903AT-11T	SN:	
Mode:	2DH5_2402	Voltage:	12V/10A
Environment:	25°C/58%	Engineer:	Roger
Remark:			
Test Standard:			

Start of Test: 2022-10-27 10:51:27

Test Graph

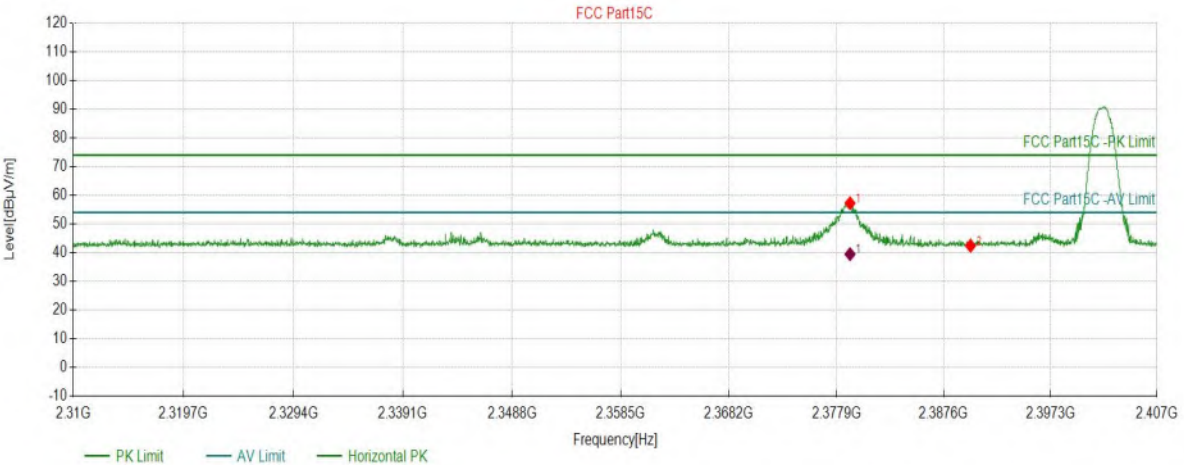

Suspected Data List									
NO.	Freq. (MHz)	Level (dBµV/m)	Factor (dB)	Limit (dBµV/m)	Margin (dB)	Height (cm)	Angle (°)	Detector	Polarity
1	2379.1194	57.23	6.44	74.00	16.77	150	285	PK	Horizontal
2	2390.0193	42.36	6.47	74.00	31.64	150	164	PK	Horizontal

AV Final Data List									
NO.	Freq. (MHz)	Factor (dB)	AV Value (dBµV/m)	AV Limit (dBµV/m)	AV Margin (dB)	Height (cm)	Angle (°)	Polarity	
1	2379.1194	6.44	39.44	54.00	14.56	150	285	Horizontal	

Test Report

Project Information			
Customer:		EUT:	Car Audio Navigation
Model:	M903AT-11T	SN:	
Mode:	2DH5_2402	Voltage:	12V/10A
Environment:	25°C/58%	Engineer:	Roger
Remark:			
Test Standard:			

Start of Test: 2022-10-27 10:52:19

Test Graph

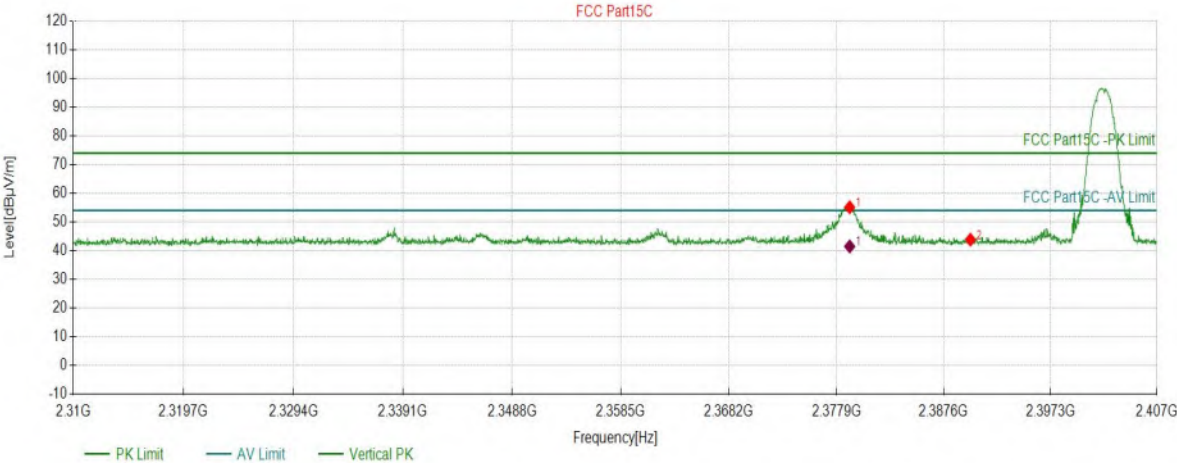

Suspected Data List									
NO.	Freq. (MHz)	Level (dBµV/m)	Factor (dB)	Limit (dBµV/m)	Margin (dB)	Height (cm)	Angle (°)	Detector	Polarity
1	2379.0870	55.09	6.44	74.00	18.91	150	163	PK	Vertical
2	2390.0193	43.82	6.47	74.00	30.18	150	205	PK	Vertical

AV Final Data List								
NO.	Freq. (MHz)	Factor (dB)	AV Value (dBµV/m)	AV Limit (dBµV/m)	AV Margin (dB)	Height (cm)	Angle (°)	Polarity
1	2379.0870	6.44	41.44	54.00	12.56	150	163	Vertical

Test Report

Project Information			
Customer:		EUT:	Car Audio Navigation
Model:	M903AT-11T	SN:	
Mode:	2DH5_2480	Voltage:	12V/10A
Environment:	25°C/58%	Engineer:	Roger
Remark:			
Test Standard:			

Start of Test: 2022-10-27 11:22:49

Test Graph

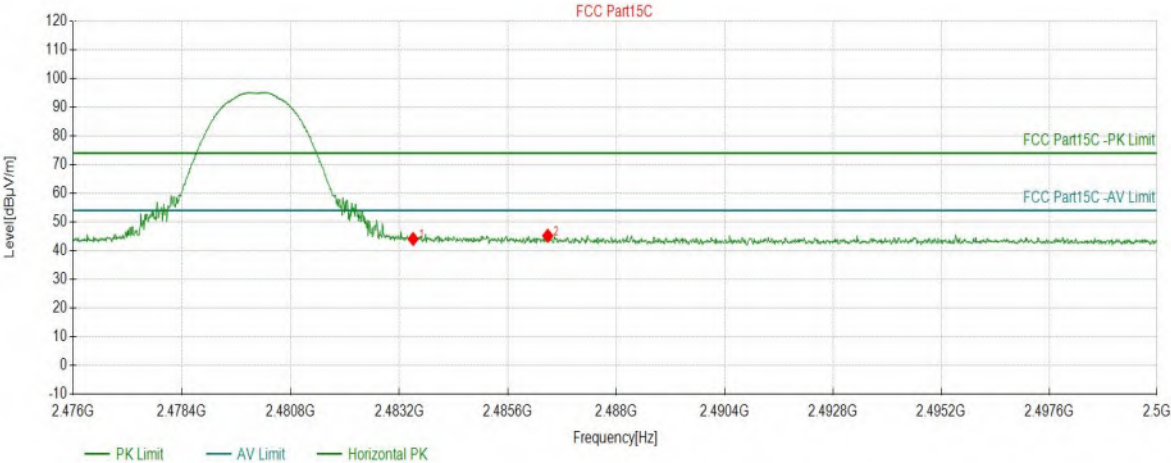

Suspected Data List									
NO.	Freq. (MHz)	Level (dBµV/m)	Factor (dB)	Limit (dBµV/m)	Margin (dB)	Height (cm)	Angle (°)	Detector	Polarity
1	2483.5038	44.04	7.09	74.00	29.96	150	349	PK	Horizontal
2	2486.4812	45.17	7.11	74.00	28.83	150	231	PK	Horizontal

Test Report

Project Information			
Customer:		EUT:	Car Audio Navigation
Model:	M903AT-11T	SN:	
Mode:	2DH5_2480	Voltage:	12V/10A
Environment:	25°C/58%	Engineer:	Roger
Remark:			
Test Standard:			

Start of Test: 2022-10-27 11:23:46

Test Graph

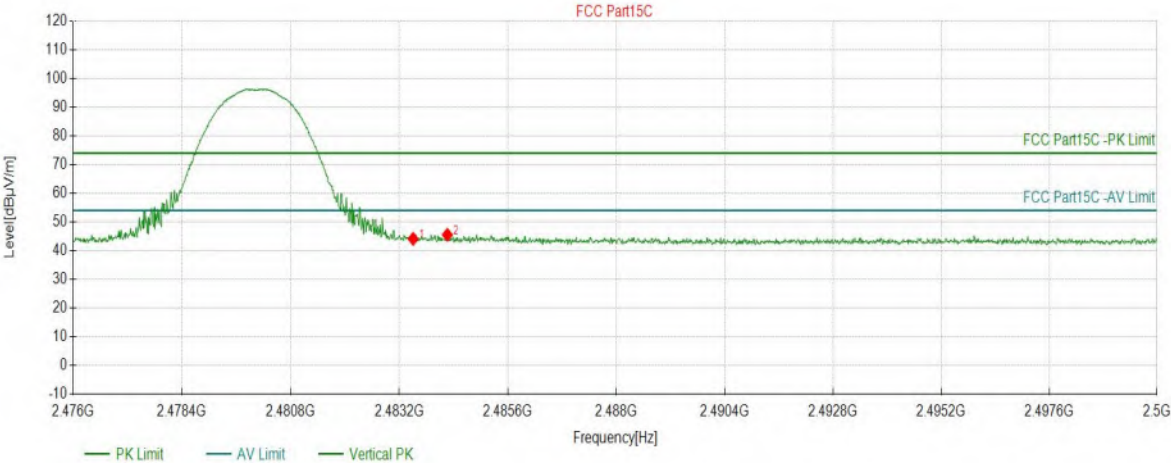

Suspected Data List									
NO.	Freq. (MHz)	Level (dBµV/m)	Factor (dB)	Limit (dBµV/m)	Margin (dB)	Height (cm)	Angle (°)	Detector	Polarity
1	2483.5038	44.08	7.09	74.00	29.92	150	328	PK	Vertical
2	2484.2601	45.49	7.10	74.00	28.51	150	322	PK	Vertical

Test Report

Project Information			
Customer:		EUT:	Car Audio Navigation
Model:	M903AT-11T	SN:	
Mode:	3DH5_2402	Voltage:	12V/10A
Environment:	25°C/58%	Engineer:	Roger
Remark:			
Test Standard:			

Start of Test: 2022-10-27 11:34:19

Test Graph

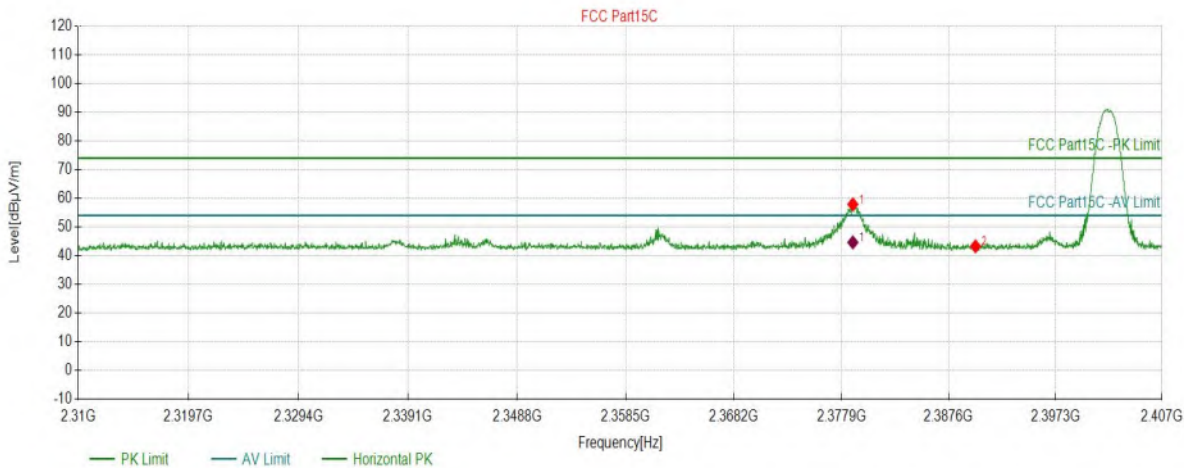

Suspected Data List									
NO.	Freq. (MHz)	Level (dBµV/m)	Factor (dB)	Limit (dBµV/m)	Margin (dB)	Height (cm)	Angle (°)	Detector	Polarity
1	2378.9253	57.88	6.44	74.00	16.12	150	288	PK	Horizontal
2	2390.0193	43.23	6.47	74.00	30.77	150	42	PK	Horizontal

AV Final Data List									
NO.	Freq. (MHz)	Factor (dB)	AV Value (dBµV/m)	AV Limit (dBµV/m)	AV Margin (dB)	Height (cm)	Angle (°)	Polarity	
1	2378.9253	6.44	44.59	54.00	9.41	150	288	Horizontal	

Test Report

Project Information			
Customer:		EUT:	Car Audio Navigation
Model:	M903AT-11T	SN:	
Mode:	3DH5_2402	Voltage:	12V/10A
Environment:	25°C/58%	Engineer:	Roger
Remark:			
Test Standard:			

Start of Test: 2022-10-27 11:35:12

Test Graph

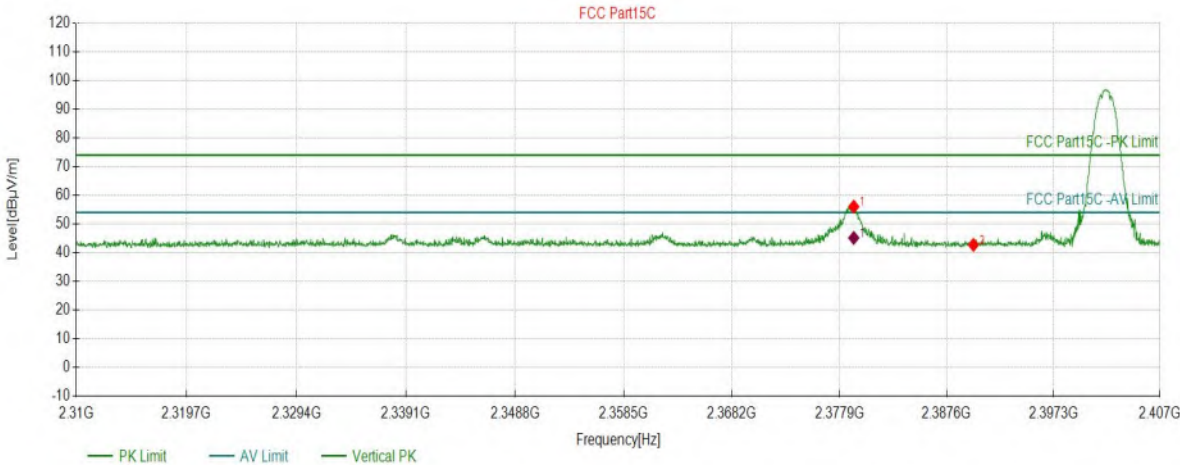

Suspected Data List									
NO.	Freq. (MHz)	Level (dBµV/m)	Factor (dB)	Limit (dBµV/m)	Margin (dB)	Height (cm)	Angle (°)	Detector	Polarity
1	2379.1841	56.02	6.44	74.00	17.98	150	257	PK	Vertical
2	2390.0193	42.69	6.47	74.00	31.31	150	50	PK	Vertical

AV Final Data List								
NO.	Freq. (MHz)	Factor (dB)	AV Value (dBµV/m)	AV Limit (dBµV/m)	AV Margin (dB)	Height (cm)	Angle (°)	Polarity
1	2379.1841	6.44	45.12	54.00	8.88	150	257	Vertical

Test Report

Project Information			
Customer:		EUT:	Car Audio Navigation
Model:	M903AT-11T	SN:	
Mode:	3DH5_2480	Voltage:	12V/10A
Environment:	25°C/58%	Engineer:	Roger
Remark:			
Test Standard:			

Start of Test: 2022-10-27 11:50:19

Test Graph

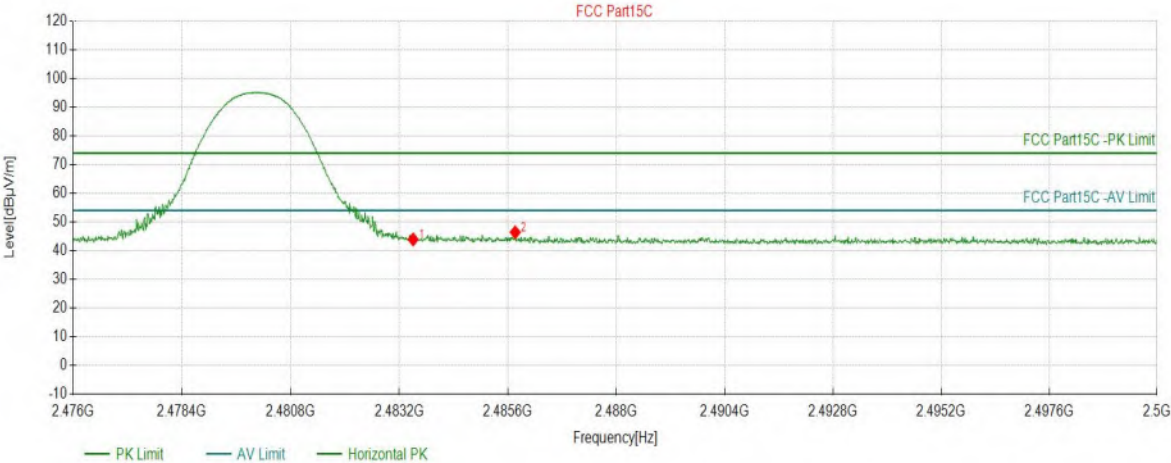

Suspected Data List									
NO.	Freq. (MHz)	Level (dBµV/m)	Factor (dB)	Limit (dBµV/m)	Margin (dB)	Height (cm)	Angle (°)	Detector	Polarity
1	2483.5038	43.87	7.09	74.00	30.13	150	50	PK	Horizontal
2	2485.7609	46.37	7.11	74.00	27.63	150	320	PK	Horizontal

Test Report

Project Information			
Customer:		EUT:	Car Audio Navigation
Model:	M903AT-11T	SN:	
Mode:	3DH5_2480	Voltage:	12V/10A
Environment:	25°C/58%	Engineer:	Roger
Remark:			
Test Standard:			

Start of Test: 2022-10-27 11:51:19

Test Graph

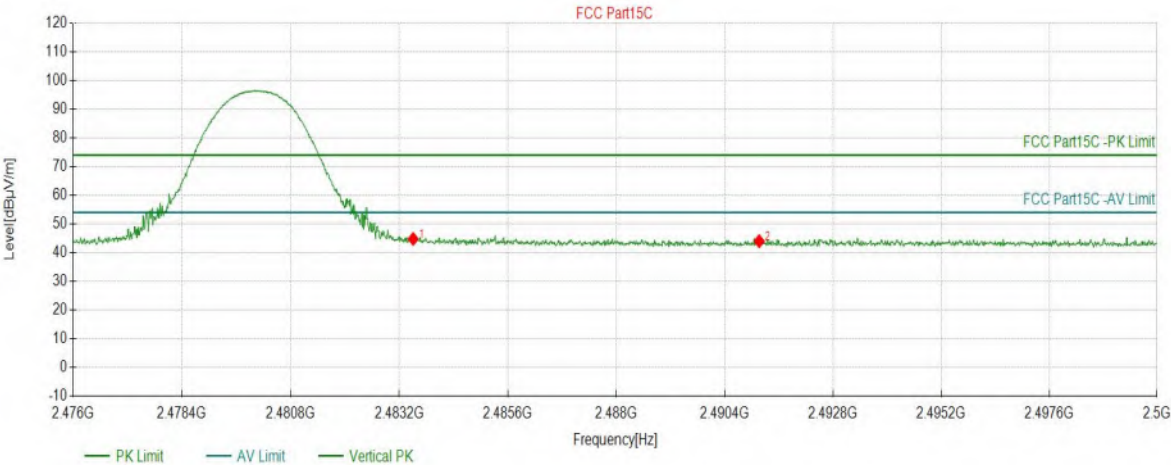

Suspected Data List									
NO.	Freq. (MHz)	Level (dBµV/m)	Factor (dB)	Limit (dBµV/m)	Margin (dB)	Height (cm)	Angle (°)	Detector	Polarity
1	2483.5038	44.75	7.09	74.00	29.25	150	322	PK	Vertical
2	2491.1636	43.96	7.15	74.00	30.04	150	30	PK	Vertical

END OF REPORT