



## Radio Test Report

**FCC ID:2A7QY-RS1**

### Original Grant

**Report No.** : TBR-C-202404-0014-31  
**Applicant** : Shenzhen Arington Technology Co., Ltd.  
**Equipment Under Test (EUT)**  
**EUT Name** : Mobile phone  
**Model No.** : RS1  
**Series Model No.** : ----  
**Brand Name** : ----  
**Sample ID** : HC-C-202404-0014-01-01# & HC-C-202404-0014-01-02#  
**Receipt Date** : 2024-05-06  
**Test Date** : 2024-05-06 to 2024-05-27  
**Issue Date** : 2024-05-27  
**Standards** : FCC Part 2, FCC Part 22 Subpart H, FCC Part 24 Subpart E,  
ANSI/TIAC63.26: 2015  
**Conclusions** : **PASS**

In the configuration tested, the EUT complied with the standards specified above,  
The EUT technically complies with the FCC requirements

**Tested By** :  Mike Yan  
**Reviewed By** :  Camille Li  
**Approved By** :  Ivan Su



This report details the results of the testing carried out on one sample. The results contained in this test report do not relate to other samples of the same product. The manufacturer should ensure that all products in series production are in conformity with the product sample detailed in the report.

# Contents

<b>CONTENTS.....</b>	<b>2</b>
<b>1. GENERAL INFORMATION ABOUT EUT.....</b>	<b>6</b>
1.1 Client Information.....	6
1.2 General Description of EUT (Equipment Under Test) .....	6
1.3 Block Diagram Showing the Configuration of System Tested.....	7
1.4 Description of Support Units .....	7
1.5 Description of Test Mode.....	8
1.6 Measurement Uncertainty .....	10
1.7 Test Facility.....	10
<b>2. TEST SUMMARY.....</b>	<b>11</b>
<b>3. TEST EQUIPMENT AND TEST SITE.....</b>	<b>12</b>
<b>4. FREQUENCY STABILITY.....</b>	<b>14</b>
4.1 Test Standard and Requirement.....	14
4.2 Test Setup.....	14
4.3 Test Procedure.....	15
4.4 EUT Operating Condition .....	15
4.5 Deviation From Test Standard.....	15
4.6 Test Data.....	15
<b>5. CONDUCTED RF OUTPUT POWER.....</b>	<b>16</b>
5.1 Test Standard and Limit.....	16
5.2 Test Setup.....	16
5.3 Test Procedure.....	16
5.4 EUT Operating Condition .....	16
5.5 Deviation From Test Standard.....	16
5.6 Test Data.....	16
<b>6. PEAK-AVERAGE RATIO.....</b>	<b>17</b>
6.1 Test Standard and Limit.....	17
6.2 Test Setup.....	17
6.3 Test Procedure.....	17
6.4 EUT Operating Condition .....	17
6.5 Deviation From Test Standard.....	17
6.6 Test Data.....	18

---

---

<b>7.</b>	<b>RADIATED OUTPUT POWER .....</b>	<b>19</b>
7.1	Test Standard and Limit.....	19
7.2	Test Setup.....	20
7.3	Test Procedure.....	20
7.4	EUT Operating Condition .....	21
7.5	Deviation From Test Standard.....	21
7.6	Test Data.....	21
<b>8.</b>	<b>OCCUPIED BANDWIDTH.....</b>	<b>22</b>
8.1	Test Standard and Limit.....	22
8.2	Test Setup.....	22
8.3	Test Procedure.....	22
8.4	EUT Operating Condition .....	23
8.5	Deviation From Test Standard.....	23
8.6	Test Data.....	23
<b>9.</b>	<b>CONDUCTED OUT OF BAND EMISSIONS.....</b>	<b>24</b>
9.1	Test Standard and Limit.....	24
9.2	Test Setup.....	24
9.3	Test Procedure.....	24
9.4	EUT Operating Condition .....	24
9.5	Deviation From Test Standard.....	24
9.6	Test Data.....	24
<b>10.</b>	<b>BAND EDGE TEST.....</b>	<b>25</b>
10.1	Test Standard and Limit .....	25
10.2	Test Setup.....	25
10.3	Test Procedure.....	25
10.4	EUT Operating Condition .....	25
10.5	Deviation From Test Standard.....	25
10.6	Test Data.....	25
<b>11.</b>	<b>RADIATED OUT BAND OF EMISSIONS.....</b>	<b>26</b>
11.1	Test Standard and Limit .....	26
11.2	Test Setup.....	26
11.3	Test Procedure.....	26
11.4	EUT Operating Condition .....	27
11.5	Deviation From Test Standard.....	27
11.6	Test Data.....	27

---

**ATTACHMENT A-- RADIATED OUTPUT POWER.....28**



# 1. General Information about EUT

## 1.1 Client Information

<b>Applicant</b>	:	Shenzhen Arington Technology Co., Ltd.
<b>Address</b>	:	501, Bldg D, Huawan Industrial Park, No.4159 Baoan Avenue, Baoan District, Shenzhen, China
<b>Manufacturer</b>	:	Shenzhen Arington Technology Co., Ltd.
<b>Address</b>	:	501, Bldg D, Huawan Industrial Park, No.4159 Baoan Avenue, Baoan District, Shenzhen, China

## 1.2 General Description of EUT (Equipment Under Test)

<b>EUT Name</b>	:	Mobile phone	
<b>HVIN/Model</b>	:	RS1	
<b>Model Different</b>	:	----	
<b>Product Description</b>	:	FCC Operating Frequency:	GSM 850: 824.20MHz-848.80MHz PCS1900: 1850.20MHz-1909.80MHz
	:	Antenna Gain:	1dBi Internal Antenna
	:	Modulation Type:	GSM/GPRS: GMSK
<b>Power Rating</b>	:	For Adapter (Model:ES007-U050055XOE) Input: 100-240V~ 50/60Hz 0.3A Output: 5.0V==0.55A, 2.75W	
<b>Li-ion Polymer Battery</b>	:	DC 3.7V by 1000mAh Rechargeable Li-ion battery	
<b>Software Version</b>	:	FD09-RS1-OUBAN-168-V1.0-20230628	
<b>Hardware Version</b>	:	FD09_MB_V1.0	
<b>Remark</b>	:	The antenna gain provided by the applicant, the verified for the RF conduction test provided by TOBY test lab.	

### Note:

For a more detailed features description, please refer to the manufacturer's specifications or the User's Manual.

### 1.3 Block Diagram Showing the Configuration of System Tested

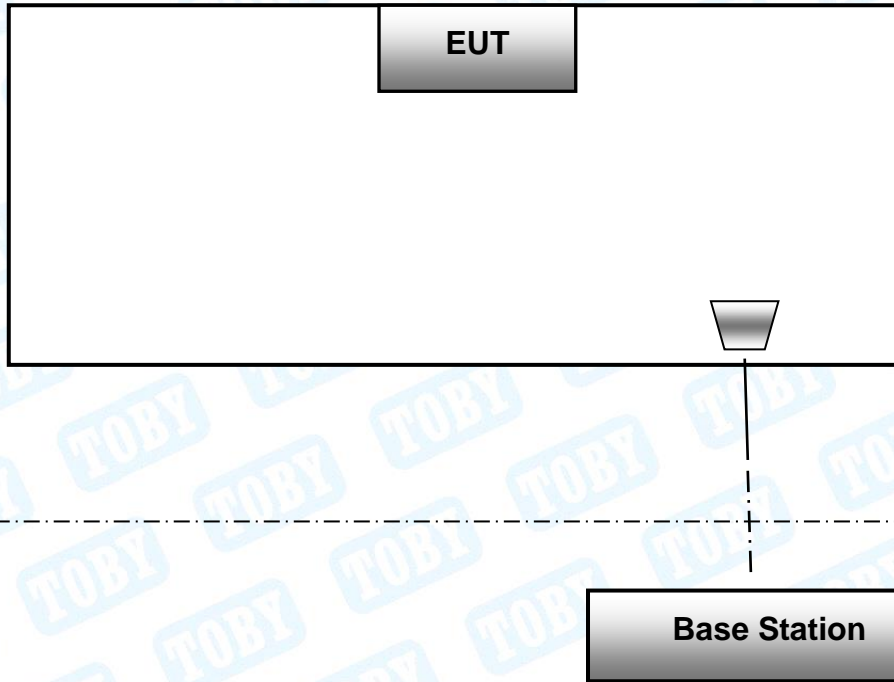

The above block diagram of setup is the normal mode. And more detail please refer to the test setup of each test item of bellow.

### 1.4 Description of Support Units

The EUT has been tested as an independent unit.

## 1.5 Description of Test Mode

To investigate the maximum EMI emission characteristics generated from EUT, the test system was pre-scanning tested based on the consideration of following EUT operation mode or test configuration mode which possibly have effect on EMI emission level. Each of these EUT operation mode(s) or test configuration mode(s) mentioned below was evaluated respectively.

During all testing, EUT is link mode with base station at maximum power level. The spurious emission measurements were carried out in semi-anechoic chamber with 3-meter test range. Frequency range investigated for radiated emission as below:

1. 9kHz~10GHz for GSM850.
2. 9kHz~20GHz for PCS1900.

Test Channel		
Mode	Channel	Frequency(MHz)
<b>GSM 850</b>	128	824.20
	190	836.60
	251	848.80
<b>PCS 1900</b>	512	1850.20
	661	1880.00
	810	1909.80



Test Mode	Description
GSM 850	highest, middle, lowest channels
GPRS 850	highest, middle, lowest channels
GSM 1900	highest, middle, lowest channels
GPRS 1900	highest, middle, lowest channels

**Note:**

- (1) The measurements are performed at the highest, middle, lowest available channels.
- (2) During the testing procedure, the EUT is in link mode with base station emulator at maximum power level in each test mode.
- (3) The EUT has GSM, GPRS functions, and after pre-testing, GSM function is the worst case for all the emission tests.
- (4) The EUT is considered a portable unit; it was pre-tested on the positioned of each 3 axis, X-plane, Y-plane and Z-plane. The worst case was found positioned on Z-plane as the normal use. Therefore only the test data of this Z-plane was used for radiated emission measurement test.

## 1.6 Measurement Uncertainty

Test Item	Parameters	Expanded Uncertainty (U <sub>Lab</sub> )
Radiated Emission	Level Accuracy: 9kHz to 30 MHz	±4.60 dB
Radiated Emission	Level Accuracy: 30MHz to 1000 MHz	±4.50 dB
Radiated Emission	Level Accuracy: Above 1000MHz	±4.20 dB

## 1.7 Test Facility

The testing report were performed by the Shenzhen Toby Technology Co., Ltd., in their facilities located at 1/F., Building 6, Rundongsheng Industrial Zone, Longzhu, Xixiang, Bao'an District, Shenzhen, Guangdong, China. At the time of testing, the following bodies accredited the Laboratory:

### **CNAS (L5813)**

The Laboratory has been accredited by CNAS to ISO/IEC 17025: 2017 General Requirements for the Competence of Testing and Calibration Laboratories for the competence in the field of testing. And the Registration No.: CNAS L5813.

### **A2LA Certificate No.: 4750.01**

The laboratory has been accredited by American Association for Laboratory Accreditation(A2LA) to ISO/IEC 17025: 2017 General Requirements for the Competence of Testing and Calibration Laboratories for the technical competence in the field of Electrical Testing. And the A2LA Certificate No.: 4750.01.FCC Accredited Test Site Number: 854351. Designation Number: CN1223.

### **IC Registration No.: (11950A)**

The Laboratory has been registered by Certification and Engineering Bureau of Industry Canada for radio equipment testing. The site registration: Site# 11950A. CAB identifier: CN0056.

## 2. Test Summary

Test Standards and Test Results			
Standard	Document Title		
FCC Part 2 (10-1-05 Edition)	Frequency Allocations and Radio Treaty Matters; General Rules and Regulations		
FCC Part 22/ 10-1-05 Edition)	Public Mobile Services		
FCC Part 24 (10-1-05 Edition)	Personal Communications Services		
Standard Section	Test Item	Judgment	Remark
2.1046	Conducted RF Output Power	PASS	N/A
24.232(d); 27.50(d)	Peak-Average Ratio	PASS	N/A
2.1049; 22.917; 24.238;	99% & -26 dB Occupied Bandwidth	PASS	N/A
2.1055; 22.355; 24.235;	Frequency Stability	PASS	N/A
2.1051; 2.1057; 22.917; 24.238	Conducted Out of Band Emissions	PASS	N/A
2.1051; 2.1057; 22.917; 24.238	Band Edge	PASS	N/A
22.913; 24.238	Transmitter Radiated Power (EIRP/ERP)	PASS	N/A
2.1051; 2.1057; 22.917; 24.238	Radiated Out of Band Emissions	PASS	N/A

**Note:** N/A is an abbreviation for Not Applicable.

### 3. Test Equipment and Test Site

Test Site				
No.	Test Site	Manufacturer	Specification	Used
TB-EMCSR001	Shielding Chamber #1	YIHENG	7.5*4.0*3.0 ( m )	√
TB-EMCSR002	Shielding Chamber #2	YIHENG	8.0*4.0*3.0 ( m )	√
TB-EMCCA001	3m Anechoic Chamber #A	ETS	9.0*6.0*6.0 ( m )	√
TB-EMCCB002	3m Anechoic Chamber #B	YIHENG	9.0*6.0*6.0 ( m )	√

Conducted Emission Test					
Equipment	Manufacturer	Model No.	Serial No.	Last Cal.	Cal. Due Date
EMI Test Receiver	Rohde & Schwarz	ESCI	100321	Jun. 20, 2023	Jun. 19, 2024
RF Switching Unit	Compliance Direction Systems Inc	RSU-A4	34403	Jun. 20, 2023	Jun. 19, 2024
AMN	SCHWARZBECK	NNBL 8226-2	8226-2/164	Jun. 20, 2023	Jun. 19, 2024
LISN	Rohde & Schwarz	ENV216	101131	Jun. 20, 2023	Jun. 19, 2024
ISN	SCHWARZBECK	NTFM 8131	8131-193	Jun. 20, 2023	Jun. 19, 2024
ISN	SCHWARZBECK	CAT3 8158	cat3 5158-0094	Jun. 20, 2023	Jun. 19, 2024
ISN	SCHWARZBECK	NTFM5158	NTFM5158 0145	Jun. 20, 2023	Jun. 19, 2024
ISN	SCHWARZBECK	CAT 8158	cat5 8158-179	Jun. 20, 2023	Jun. 19, 2024
Radiation Emission Test (A Site)					
Equipment	Equipment	Equipment	Equipment	Equipment	Equipment
Spectrum Analyzer	Rohde & Schwarz	FSV40-N	102197	Jun. 20, 2023	Jun. 19, 2024
EMI Test Receiver	Rohde & Schwarz	ESPI	100010/007	Jun. 20, 2023	Jun. 19, 2024
Bilog Antenna	ETS-LINDGREN	3142E	00117537	Feb. 27, 2024	Feb.26, 2026
Horn Antenna	ETS-LINDGREN	3117	00143207	Feb. 27, 2024	Feb.26, 2026
Horn Antenna	SCHWARZBECK	BBHA 9170	1118	Feb. 27, 2024	Feb.26, 2026
Loop Antenna	SCHWARZBECK	FMZB 1519 B	1519B-059	Jun. 26, 2022	Jun.25, 2024
Pre-amplifier	SONOMA	310N	185903	Feb. 23, 2024	Feb.22, 2025
Pre-amplifier	HP	8449B	3008A00849	Feb. 23, 2024	Feb.22, 2025
HF Amplifier	Tonscend	TAP0184050	AP21C806129	Feb. 27, 2024	Feb.26, 2026
Radiation Emission Test (B Site)					
Equipment	Manufacturer	Model No.	Serial No.	Last Cal.	Cal. Due Date
Spectrum Analyzer	Agilent	N9020A	MY49100060	Aug. 30, 2023	Aug. 29, 2024
Spectrum Analyzer	Rohde & Schwarz	FSV40-N	102197	Jun. 20, 2023	Jun. 19, 2024

EMI Test Receiver	Rohde & Schwarz	ESU-8	100472/008	Feb. 23, 2024	Feb.22, 2025
Bilog Antenna	SCHWARZBECK	VULB 9168	1225	Nov. 13, 2023	Nov. 12, 2025
Horn Antenna	SCHWARZBECK	BBHA 9120 D	2463	Jun. 26, 2022	Jun.25, 2024
Horn Antenna	SCHWARZBECK	BBHA 9170	1118	Feb. 27, 2024	Feb.26, 2026
Loop Antenna	SCHWARZBECK	FMZB 1519 B	1519B-059	Jun. 26, 2022	Jun.25, 2024
HF Amplifier	Tonscend	TAP9E6343	AP21C806117	Aug. 30, 2023	Aug. 29, 2024
HF Amplifier	Tonscend	TAP051845	AP21C806141	Aug. 30, 2023	Aug. 29, 2024
HF Amplifier	Tonscend	TAP0184050	AP21C806129	Aug. 30, 2023	Aug. 29, 2024
Highpass Filter	CD	HPM-6.4/18G	---	N/A	N/A
Highpass Filter	CD	HPM-2.8/18G	---	N/A	N/A
Highpass Filter	XINBO	XBLBQ-HTA67(8-25G)	22052702-1	N/A	N/A

**Antenna Conducted Emission**

Equipment	Manufacturer	Model No.	Serial No.	Last Cal.	Cal. Due Date
Spectrum Analyzer	Rohde & Schwarz	FSV40-N	102197	Jun. 20, 2023	Jun. 19, 2024
MXA Signal Analyzer	KEYSIGHT	N9020B	MY60110172	Aug. 30, 2023	Aug. 29, 2024
MXA Signal Analyzer	Agilent	N9020A	MY47380425	Aug. 30, 2023	Aug. 29, 2024
Vector Signal Generator	Agilent	N5182A	MY50141294	Aug. 30, 2023	Aug. 29, 2024
Analog Signal Generator	Agilent	N5181A	MY48180463	Aug. 30, 2023	Aug. 29, 2024
Vector Signal Generator	KEYSIGHT	N5182B	MY59101429	Aug. 30, 2023	Aug. 29, 2024
Analog Signal Generator	KEYSIGHT	N5173B	MY61252685	Aug. 30, 2023	Aug. 29, 2024
RF Power Sensor	DARE!! Instruments	RadiPowerRPR3006W	17100015SNO26	Aug. 30, 2023	Aug. 29, 2024
	DARE!! Instruments	RadiPowerRPR3006W	17100015SNO29	Aug. 30, 2023	Aug. 29, 2024
	DARE!! Instruments	RadiPowerRPR3006W	17100015SNO31	Aug. 30, 2023	Aug. 29, 2024
	DARE!! Instruments	RadiPowerRPR3006W	17100015SNO33	Aug. 30, 2023	Aug. 29, 2024
RF Control Unit	Tonsced	JS0806-1	21C8060380	N/A	N/A
RF Control Unit	Tonsced	JS0806-2	21F8060439	Aug. 30, 2023	Aug. 29, 2024
Power Control Box	Tonsced	JS0806-4ADC	21C8060387	N/A	N/A
Wideband Radio Communication Tester	Rohde & Schwarz	CMW500	144382	Aug. 30, 2023	Aug. 29, 2024
Universal Radio Communication Tester	Rohde&Schwarz	CMW500	168796	Feb. 23, 2024	Feb. 22, 2025
Temperature and Humidity Chamber	ZhengHang	ZH-QTH-1500	ZH2107264	Jun. 20, 2023	Jun. 19, 2024

## 4. Frequency Stability

### 4.1 Test Standard and Requirement

#### 4.1.1 Test Standard

FCC Part 2.1055

FCC Part 22.355

FCC Part 24.235

#### 4.1.2 Requirement

According to FCC section 22.355 and FCC section 24.235, the frequency stability shall be sufficient to ensure that the fundamental emission stays within the authorized frequency block.

According to FCC section 2.1055, the test conditions are:

(1) Temperature:

The temperature is varied from  $-30^{\circ}\text{C}$  to  $+50^{\circ}\text{C}$  at intervals of not more than  $10^{\circ}\text{C}$ .

(2) Primary Supply Voltage:

For hand carried battery powered equipment, the primary supply voltage is reduced to the battery operating end point which shall be specified by the manufacture. The supply voltage shall be measured at input to the cable normally provide with the equipment, or at the power supply terminals if cables are not normally provided.

### 4.2 Test Setup

For Temperature Test:

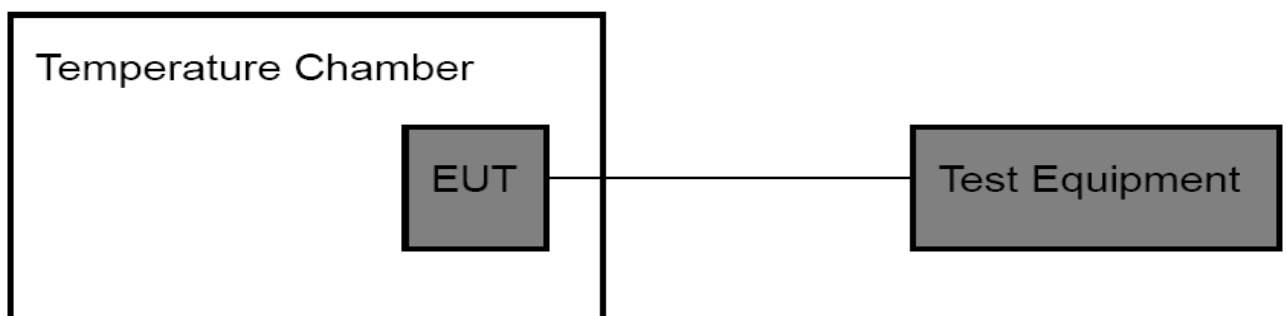

For Voltage Test:

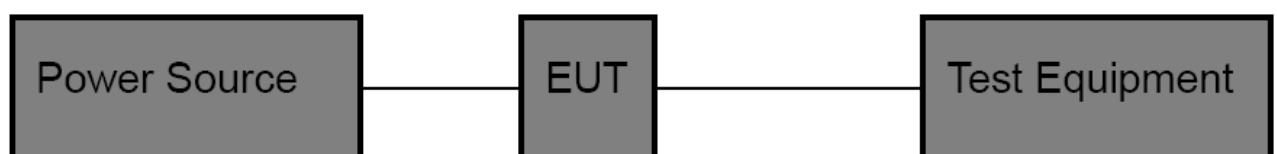

### 4.3 Test Procedure

Test Procedures for Temperature Variation:

- (1) The EUT was set up in the thermal chamber and connected with the base station.
- (2) With power off, the temperature was decreased to  $-30^{\circ}\text{C}$  and the EUT was stabilized for three hours. Power was applied and the maximum change in frequency was recorded within one minute.
- (3) With power off, the temperature was raised in  $10^{\circ}\text{C}$  set up to  $50^{\circ}\text{C}$  and the EUT was stabilized for three hours. Power was applied and the maximum change in frequency was recorded within one minute.
- (4) If the EUT cannot be turned on at  $-30^{\circ}\text{C}$ , the testing lowest temperature will be raised in  $10^{\circ}\text{C}$  step until the EUT can be turned on.

Test Procedures for Voltage Variation:

- (1) The EUT was placed in a temperature chamber at  $25 \pm 5^{\circ}\text{C}$  and connected with the base station.
- (2) Reduce the input voltage to specify extreme voltage variation ( $\pm 15\%$ ) and endpoint, record the maximum frequency change.
- (3) The variation in frequency was measured for the worst case.

### 4.4 EUT Operating Condition

The Equipment Under Test was set to Communication with the Base Station.

### 4.5 Deviation From Test Standard

No deviation

### 4.6 Test Data

Please refer to the Appendix B Test Data - **Frequency Stability**.

## 5. Conducted RF Output Power

### 5.1 Test Standard and Limit

#### 5.1.1 Test Standard

FCC Part 2: 2.1046

FCC Part 22H : 22.913 (a)

FCC Part 24E: 24.232 (c)

#### 5.1.2 Test Limit

GSM850/UMTS Band V	UMTS Band IV	PCS 1900/UMTS Band II
38.5 dBm (ERP)	30 dBm (EIRP)	33 dBm (EIRP)

### 5.2 Test Setup

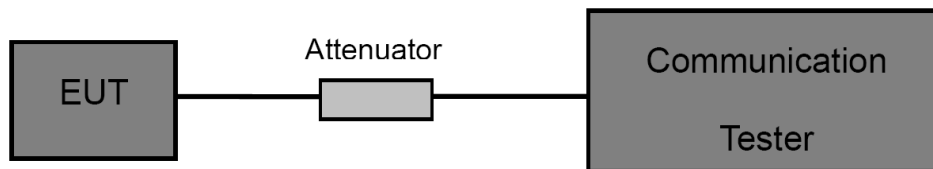

### 5.3 Test Procedure

- (1) The EUT is coupled to the Base Station with the suitable Attenuator, the path loss is calibrated to correct the reading.
- (2) A call is set up by the Base Station to the generic call set up procedure.
- (3) Set EUT at maximum power level through base station by power level command.
- (4) Then read record the power value from the Base Station in dBm.

### 5.4 EUT Operating Condition

The EUT was continuously connected with the Base station and transmitting in the max power during the test.

### 5.5 Deviation From Test Standard

No deviation

### 5.6 Test Data

Please refer to the Appendix B Test Data - **Conducted RF Output Power**.



## 6. Peak-Average Ratio

### 6.1 Test Standard and Limit

#### 6.1.1 Test Standard

FCC Part 24E: 24.232 (d)

#### 6.1.2 Test Limit

#### Peak-to-Average Ratio

The peak-to-average ratio (PAR) of the transmission may not exceed 13 dB.

### 6.2 Test Setup

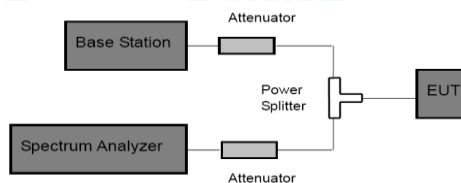

### 6.3 Test Procedure

According with KDB 971168

- (1) The signal analyzer's CCDF measurement profile is enabled.
- (2) Frequency = carrier center frequency.
- (3) Measurement BW > Emission bandwidth of signal.
- (4) The signal analyzer was set to collect one million samples to generate the CCDF curve.
- (5) The measurement interval was set depending on the type of signal analyzed. For continuous signals (>98% duty cycle), the measurement interval was set to 1ms. For burst transmissions, the spectrum analyzer is set to use an internal "RF Burst" trigger that is synced with an incoming pulse and the measurement interval is set to less than the duration of the "on time" of one burst to ensure that energy is only captured during a time in which of the transmitter is operating at maximum power.

### 6.4 EUT Operating Condition

The EUT was continuously connected with the Base station and transmitting in the max power during the test.

### 6.5 Deviation From Test Standard

No deviation

## 6.6 Test Data

Please refer to the Appendix B Test Data - **Peak-to-Average Ratio**.

## 7. Radiated Output Power

### 7.1 Test Standard and Limit

#### 7.1.1 Test Standard

FCC Part 22H: 22.913 (a)

FCC Part 24E: 24.232 (c)

FCC Part 24E

#### 7.1.2 Test Limit

According to FCC Part 22.913 (a), the ERP of Cellular mobile transmitters must not exceed 7 Watts(38.5 dBm).

According to FCC Part 24.232 (c), the Mobile/portable stations are limited to 2 Watts(33 dBm) EIRP peak power.

According to FCC Part 27.50 (d)(4), Fixed, mobile, and portable (hand-held) stations operating in the 1710-1755 MHz band and mobile and portable stations operating in the 1695-1710 MHz and 1755-1780 MHz bands are limited to 1 watt EIRP. Fixed stations operating in the 1710-1755 MHz band are limited to a maximum antenna height of 10 meters above ground. Mobile and portable stations operating in these bands must employ a means for limiting power to the minimum necessary for successful communications.

<b>GSM850/UMTS Band V</b>	<b>UMTS Band IV</b>	<b>PCS 1900/UMTS Band II</b>
38.5 dBm (ERP)	30 dBm (EIRP)	33 dBm (EIRP)

## 7.2 Test Setup

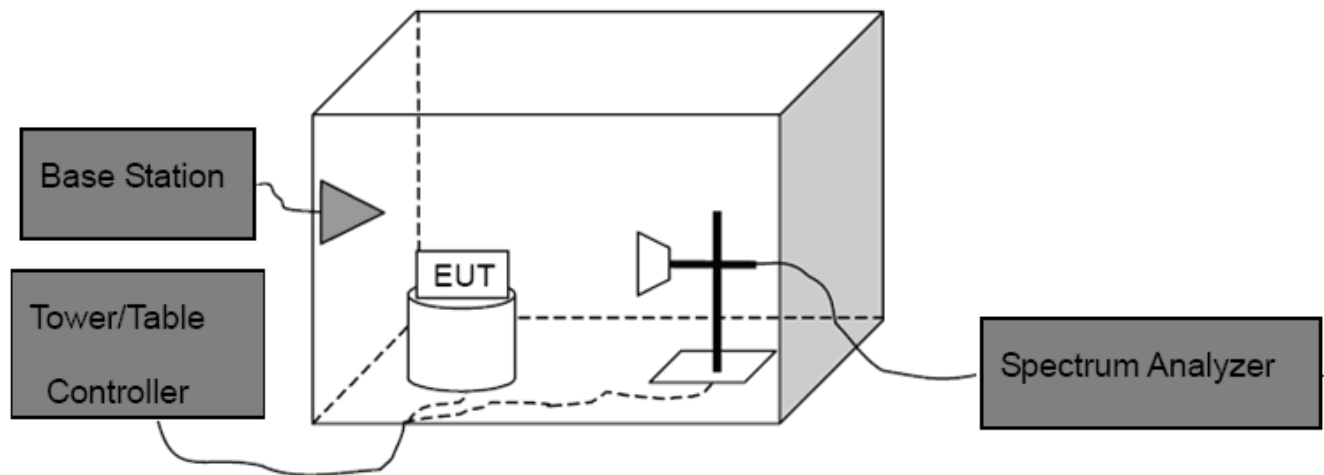

### Above 1G

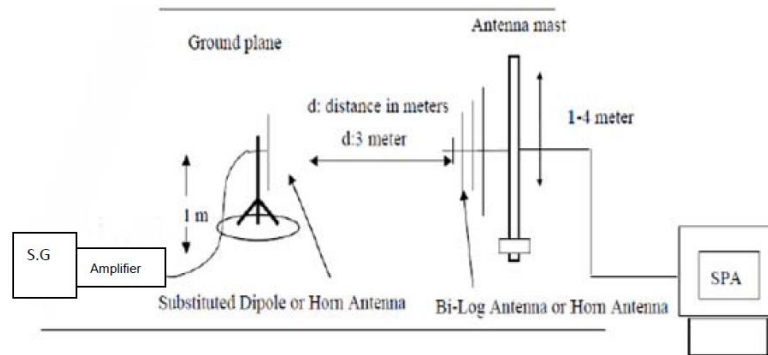

### Substituted Method

## 7.3 Test Procedure

- (1) The EUT was placed on an non-conductive rotating platform with 0.8 meter height in an anechoic chamber. The radiated emission at the fundamental frequency was measured at 3 m with a test antenna and a spectrum analyzer with RBW=3 MHz, VBW=3 MHz and peak detector settings.
- (2) During the measurement, the EUT was enforced in maximum power and linked with the Base Station. The highest was recorded from analyzer power level (LVT) from the 360 degrees rotation of the turntable and the test antenna raised and lowered over a range from 1 to 4 meters in both horizontally and vertically polarized orientations.
- (3) Effective Isotropic Radiated Power (EIRP) was measured by substitution method according to C63.26. The EUT was replaced by dipole antenna (for frequency below 1 GHz) or Horn antenna (for frequency above 1 GHz) at same location with same polarize of receiver antenna and then a known power of each measure frequency from S.G. was applied into the

dipole antenna or Horn antenna through a TX cable, and then recorded the maximum Analyzer reading through raised and lowered the test antenna.

**Note: In test, the S.G Connect the Pre-amplifier(Sonoma 310N Pre-amplifier for frequency below 1 GHz, HP 8449B Pre-amplifier for frequency above 1 GHz )**

Then the EUT's EIRP and ERP was calculated with the correction factor:

$ERP = S.G.Level + Antenna\ Gain\ Cord.(dBd) - Cable\ Loss(dB)$

$EIRP = S.G.Level + Antenna\ Gain\ Cord.(dBi) - Cable\ Loss(dB)$

#### 7.4 EUT Operating Condition

The EUT was continuously connected with the Base station and transmitting in the max power during the test.

#### 7.5 Deviation From Test Standard

No deviation

#### 7.6 Test Data

Please refer to the Attachment A.

## 8. Occupied Bandwidth

### 8.1 Test Standard and Limit

#### 8.1.1 Test Standard

FCC Part 2: 2.1049

#### 8.1.2 Test Requirement

According to FCC section 2.1049, the occupied bandwidth is the frequency bandwidth such that below its lower and above its upper frequency limits, the mean powers radiated are each equal to 0.5 percent of the total mean power radiated by a given emission.

Occupied bandwidth is also known as 99% power and -26dBC occupied bandwidths.

### 8.2 Test Setup

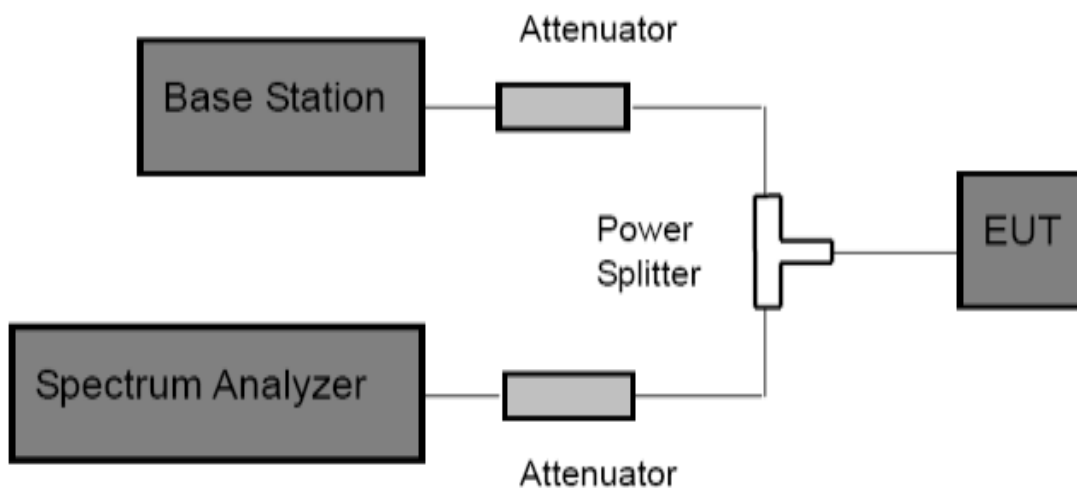

### 8.3 Test Procedure

- (1) The EUT was directly connected to the spectrum analyzer and Base station via power splitter as show in the block diagram above.
- (2) The resolution bandwidth of the Spectrum Analyzer is set to at least 1% of the occupied bandwidth.
- (3) The low, middle and the high channels are selected to perform tests respectively.
- (4) Set the frequency range of the Spectrum Analyzer suitably to capture the waveform; search peak; make a line whose value is 26dB lower than the peak; mark two points which the line intersected the waveform at; finally record the delta of the two points as the occupied bandwidth and the plot.
- (5) Set the Spectrum Analyzer Occupied bandwidth function to measure the 99% occupied bandwidth.

## 8.4 EUT Operating Condition

The EUT was continuously connected with the Base station and transmitting in the max power during the test.

## 8.5 Deviation From Test Standard

No deviation

## 8.6 Test Data

Please refer to the Appendix B Test Data - **26dB Bandwidth and Occupied Bandwidth.**

## 9. Conducted Out of Band Emissions

### 9.1 Test Standard and Limit

#### 9.1.1 Test Standard

FCC Part 2: 2.1051, 2.1057

FCC Part 22H: 22.917(a)

FCC Part 24E: 24.238(a)

#### 9.1.2 Test Limit

The power of any emission outside of the authorized operating frequency ranges must be attenuated below the transmitting power(P) by a factor of at least  $43+10\log(P)$  dB. For all power levels +30 dBm to 0 dBm, this becomes a constant specification limit of -13 dBm.

### 9.2 Test Setup

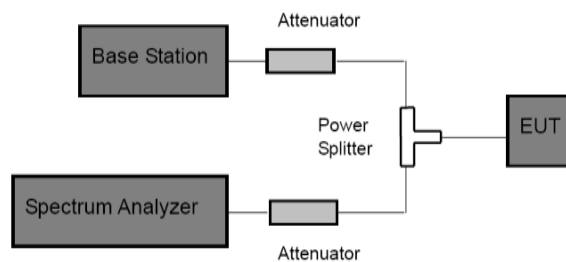

### 9.3 Test Procedure

- (1) The EUT was directly connected to the spectrum analyzer and Base station via power splitter as show in the block diagram above.
- (2) Spectrum Setting:  
Frequency bellow 1 GHz: RBW=100 kHz, VBW=300 kHz.  
Frequency above 1 GHz: RBW=1 MHz, VBW=3 MHz.
- (3) The low, middle and high channels of each band and mode's spurious emissions for 30 MHz to 10<sup>th</sup> Harmonic were measured by Spectrum analyzer.

### 9.4 EUT Operating Condition

The EUT was continuously connected with the Base station and transmitting in the max power during the test.

### 9.5 Deviation From Test Standard

No deviation

### 9.6 Test Data

Please refer to the Appendix B Test Data - **Conducted Spurious Emission.**



## 10. Band Edge Test

### 10.1 Test Standard and Limit

#### 10.1.1 Test Standard

FCC Part 2: 2.1051, 2.1057

FCC Part 22H: 22.917(a)

FCC Part 24E: 24.238(a)

#### 10.1.2 Test Limit

The power of any emission outside of the authorized operating frequency ranges must be attenuated below the transmitting power(P) by a factor of at least  $43+10\log(P)$  dB. For all power levels +30 dBm to 0 dBm, this becomes a constant specification limit of -13 dBm.

### 10.2 Test Setup

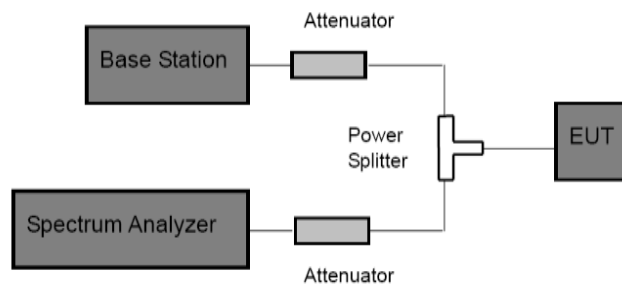

### 10.3 Test Procedure

(1) The EUT was directly connected to the spectrum analyzer and Base station via power splitter as show in the block diagram above.

(2) Spectrum Setting:

GSM and PCS:  $RBW \geq 1\%$  26db bandwidth,  $VBW=3$  RBW, Span 1 MHz, Detector: Peak Mode.

WCDMA:  $RBW \geq 1\%$  26db bandwidth,  $VBW=3$  RBW, Span 10 MHz, Detector: Peak Mode.

(3) The band edges of low and high channels for the highest RF powers were measured.

### 10.4 EUT Operating Condition

The EUT was continuously connected with the Base station and transmitting in the max power during the test.

### 10.5 Deviation From Test Standard

No deviation

### 10.6 Test Data

Please refer to the Appendix B Test Data - **Band Edge**.

## 11. Radiated Out Band of Emissions

### 11.1 Test Standard and Limit

#### 11.1.1 Test Standard

FCC Part 2: 2.1053, 2.1057

FCC Part 22H: 22.917

FCC Part 24E: 24.238

#### 11.1.2 Test Limit

The power of any emission outside of the authorized operating frequency ranges must be attenuated below the transmitting power(P) by a factor of at least  $43+10\log(P)$  dB. For all power levels +30 dBm to 0 dBm, this becomes a constant specification limit of -13 dBm.

### 11.2 Test Setup

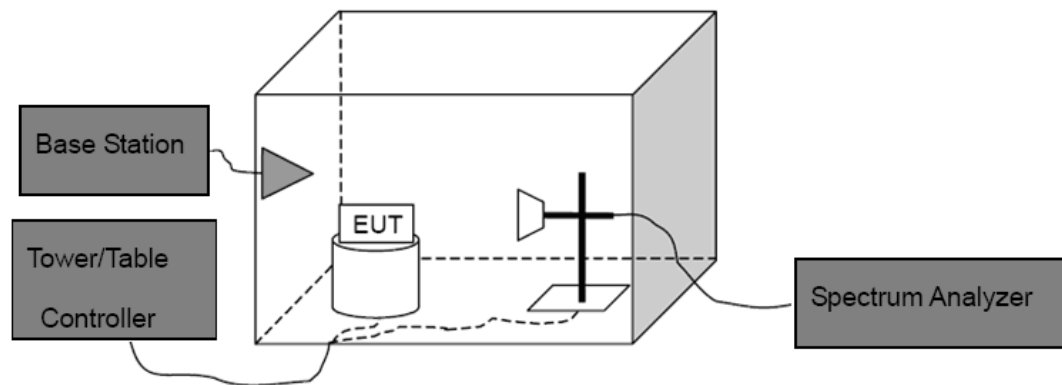

### 11.3 Test Procedure

- (1) The test system setup as show in the block diagram above.
- (2) The EUT was placed on an non-conductive rotating platform in an anechoic chamber. The radiated spurious emissions from 30MHz to 10<sup>th</sup> harmonious of fundamental frequency were measured at 3 m with a test antenna and a spectrum analyzer with RBW=1 MHz, VBW=1 MHz, peak detector settings.
- (3) During the measurement, the EUT was enforced in maximum power and linked with a base station. All the spurious emissions at 3m were measured by rotation of the turntable and the test antenna raised and lowered over a range from 1 to 4 meters in both horizontally and vertically polarized orientations.
- (4) When found the maximum level of emissions from the EUT. Remove the EUT and replace it with substitution antenna. A signal generator was connected to the substitution antenna by a non-radiating cable. The absolute levels of the spurious emissions were measured by the substitution.

Spurious emissions in dB=10 log(TX power in Watts/0.001)-the absolute level

Spurious attenuation limit in dB=43+10 log(power out in Watts)

#### 11.4 EUT Operating Condition

The EUT was continuously connected with the Base station and transmitting in the max power during the test.

#### 11.5 Deviation From Test Standard

No deviation

#### 11.6 Test Data

Please refer to the Attachment B.

## Attachment A-- Radiated Output Power

GSM 850							
Mode	Channel	Frequency (MHz)	Antenna (H&V)	SG Level (dBm)	Antenna Factor (dBd)	Cable Loss (dB)	ERP Power (dBm)
GSM 850	128	824.2	H	17.51	5.01	2.59	19.93
			V	16.52	5.01	2.59	18.94
	190	836.6	H	22.01	4.82	2.59	24.24
			V	19.30	4.82	2.59	21.53
	251	848.8	H	22.96	4.45	2.59	24.82
			V	14.19	4.45	2.59	16.05
GPRS 850 (1 Slot)	128	824.2	H	21.98	5.01	2.59	24.40
			V	18.77	5.01	2.59	21.19
	190	836.6	H	17.59	4.82	2.59	19.82
			V	15.92	4.82	2.59	18.15
	251	848.8	H	22.23	4.45	2.59	24.09
			V	16.15	4.45	2.59	18.01
<b>Limit</b>							<b>38.5</b>

PCS 1900							
Mode	Channel	Frequency (MHz)	Antenna (H&V)	SG Level (dBm)	Antenna Factor (dBi)	Cable Loss (dB)	EIRP Power (dBm)
GSM 1900	512	1850.2	H	18.17	5.01	2.59	20.59
			V	16.67	5.01	2.59	19.09
	661	1880.0	H	21.24	4.82	2.59	23.47
			V	15.62	4.82	2.59	17.85
	810	1909.8	H	22.81	4.45	2.59	24.67
			V	17.53	4.45	2.59	19.39
GPRS 1900 (1 Slot)	512	1850.2	H	19.47	5.01	2.59	21.89
			V	15.41	5.01	2.59	17.83
	661	1880.0	H	17.48	4.82	2.59	19.71
			V	15.66	4.82	2.59	17.89
	810	1909.8	H	20.37	4.45	2.59	22.23
			V	19.00	4.45	2.59	20.86
<b>Limit</b>							<b>33</b>

## Attachment B--Radiated Out Band of Emissions

Measurement Data (worst case)

Test mode:		GSM 850					
Channel:		Middle					
Frequency (MHz)	Spurious Emission					Limit (dBm)	Result
	Polarization (H&V)	Read Level (dBm)	Antenna Correct Factor (dBi)	Cable Loss (dB)	Emission Level (dBm)		
1676.37	Horizontal	-57.05	14.94	6.12	-35.99	-13.00	Pass
2444.47	H	-63.96	13.87	7.86	-42.23		
3217.71	H	-70.38	14.49	9.54	-46.35		
1769.85	Vertical	-35.29	8.02	3.97	-23.30	-13.00	Pass
2566.04	V	-44.12	10.47	5.05	-28.60		
3245.30	V	-57.98	16.92	5.98	-35.08		

Remark: 1, The testing has been conformed to  $10 \times 836.6\text{MHz} = 8,366\text{MHz}$ .  
 2, All other emissions more than 30 dB below the limit.  
 3, Emission Level= Read Level+ Antenna Correct Factor +Cable Loss

Test mode:		GSM 1900					
Channel:		Middle					
Frequency (MHz)	Spurious Emission					Limit (dBm)	Result
	Polarization (H&V)	Read Level (dBm)	Antenna Correct Factor (dBi)	Cable Loss (dB)	Emission Level (dBm)		
3617.48	Horizontal	-54.43	14.94	6.12	-33.37	-13.00	Pass
5728.82	H	-65.19	13.87	7.86	-43.46		
7309.45	H	-70.77	14.49	9.54	-46.74		
3894.61	Vertical	-35.70	8.02	3.97	-23.71	-13.00	Pass
5239.17	V	-46.88	10.47	5.05	-31.36		
7383.98	V	-55.92	16.92	5.98	-33.02		

Remark: 1, The testing has been conformed to  $10 \times 1880.0\text{MHz} = 18,800\text{MHz}$ .  
 2, All other emissions more than 30 dB below the limit.  
 3, Emission Level= Read Level+ Antenna Correct Factor +Cable Loss

-----End of the Report-----