



FCC TEST REPORT

FCC ID: 2A70T-H6

Report Number : ZKT-230411L2592E

Date of Test Mar. 27, 2023 to Apr. 11, 2023

Date of issue : Apr. 11, 2023

Total number of pages 23

Test Result : PASS

Testing Laboratory..... : **Shenzhen ZKT Technology Co., Ltd.**

Address : 1/F, No. 101, Building B, No. 6, Tangwei Community Industrial Avenue, Fuhai Street, Bao'an District, Shenzhen, China

Applicant's name : **Shenzhen View lighting Technology Co., Ltd**

Address : 301, Building d, Xinwei Third Industrial Zone, Xinshi Community, Dalang Street, Longhua District, Shenzhen City

Manufacturer's name : **Shenzhen View lighting Technology Co., Ltd**

Address : 301, Building d, Xinwei Third Industrial Zone, Xinshi Community, Dalang Street, Longhua District, Shenzhen City

Test specification:

Standard..... : FCC CFR Title 47 Part 15 Subpart C

Test procedure..... : /

Non-standard test method : N/A

Test Report Form No. : TRF-EL-107_V0

Test Report Form(s) Originator : ZKT Testing

Master TRF : Dated: 2023-4-11

This device described above has been tested by ZKT, and the test results show that the equipment under test (EUT) is in compliance with the FCC requirements. And it is applicable only to the tested sample identified in the report.

This report shall not be reproduced except in full, without the written approval of ZKT, this document may be altered or revised by ZKT, personal only, and shall be noted in the revision of the document.

Product name : Wireless Charging Station

Trademark : N/A

Model/Type reference : H6
H6-1, H6-2, L3, L3-1, H8
Input: DC 5V/2A, 9V/2A, 12V2A

Ratings..... : Wireless Output:
Phone(Phone): 5W/7.5W/10W/15W
Earphone(Earphone): 5W
Watch(Watch): 3W



Testing procedure and testing location:

Testing Laboratory.....: **Shenzhen ZKT Technology Co., Ltd.**

Address.....: 1/F, No. 101, Building B, No. 6, Tangwei Community Industrial Avenue, Fuhai Street, Bao'an District, Shenzhen, China

Tested by (name + signature): Jim Liu

Reviewer (name + signature).....: Jackson Fang

Approved (name + signature): Lake Xie





TABLE OF CONTENTS

1. VERSION	4
2. TEST SUMMARY	5
2.1 TEST FACILITY	6
2.2 MEASUREMENT UNCERTAINTY	6
3. GENERAL INFORMATION	7
3.1 GENERAL DESCRIPTION OF EUT	7
3.2 Test mode.....	7
3.3 Block Diagram of EUT Configuration	7
3.5 Description Of Support Units (Conducted Mode)	8
3.6 EQUIPMENTS LIST FOR ALL TEST ITEMS	9
4. CONDUCTED EMISSION TEST	10
4.1 CONDUCTED EMISSION MEASUREMENT	10
4.1.1 POWER LINE CONDUCTED EMISSION Limits.....	10
4.1.2 TEST PROCEDURE	10
4.1.3 DEVIATION FROM TEST STANDARD.....	10
4.1.4 TEST SETUP.....	11
4.1.5 EUT OPERATING CONDITIONS.....	11
4.1.6 Test Result	11
5. RADIATED EMISSION MEASUREMENT	14
5.1 Radiated Emission Limits.....	14
5.2 Anechoic Chamber Test Setup Diagram	15
5.3 Test Procedure	15
5.4 Deviation From Test Standard	15
5.5 Test Result	16
6. BANDWIDTH TEST	19
6.1 Limits	19
6.2 Test Setup	19
6.3 Test Result	19
7. ANTENNA REQUIREMENT	22
8. TEST SETUP PHOTO	23
9. EUT CONSTRUCTIONAL DETAILS	23



1. VERSION

Report No.	Version	Description	Approved
ZKT-230411L2592E	Rev.01	Initial issue of report	Apr. 11, 2023



2. TEST SUMMARY

Test Item	Section in CFR 47	Result
Antenna requirement	15.203	Pass
AC Power Line Conducted Emission	15.207	Pass
Spurious Emission	15.209(a)(f)	Pass
20dB Bandwidth	15.215	Pass

NOTE:

(1) "N/A" denotes test is not applicable in this Test Report



2.1 TEST FACILITY

Shenzhen ZKT Technology Co., Ltd.
Add. : 1/F, No. 101, Building B, No. 6, Tangwei Community Industrial Avenue, Fuhai Street,
Bao'an District, Shenzhen, China

FCC Test Firm Registration Number: 692225
Designation Number: CN1299
IC Registered No.: 27033

2.2 MEASUREMENT UNCERTAINTY

The reported uncertainty of measurement $y \pm U$, where expanded uncertainty U is based on a standard uncertainty multiplied by a coverage factor of $k=2$, providing a level of confidence of approximately 95 %.

No.	Item	Uncertainty
1	3m chamber Radiated spurious emission(9KHz-30MHz)	U=4.5dB
2	3m chamber Radiated spurious emission(30MHz-1GHz)	U=4.8dB
3	3m chamber Radiated spurious emission(1GHz-18GHz)	U=4.9dB
4	3m chamber Radiated spurious emission(18GHz-40GHz)	U=5.0dB
5	Conducted Adjacent channel power	U=1.38dB
6	Conducted output power uncertainty Above 1G	U=1.576dB
7	Conducted output power uncertainty below 1G	U=1.28dB
8	humidity uncertainty	U=5.3%
9	Temperature uncertainty	U=0.59°C



3. GENERAL INFORMATION

3.1 GENERAL DESCRIPTION OF EUT

Product Name:	Wireless Charging Station
Model No.:	H6
Model Difference:	Except for the model and appearance, all models have the same circuit and module.
Serial No.:	H6-1, H6-2, L3, L3-1, H8
Hardware version:	WGY-0923_V1.1
Software version:	V1.0
Operation Frequency:	Phone:115kHz-205kHz Earphone:115kHz-205kHz Watch:328.2kHz
Modulation type:	FSK
Antenna Type:	Inductive loop coil Antenna
Antenna gain:	0dBi
Power supply:	Input: DC 5V/2A, 9V/2A, 12V2A Wireless Output: Phone(Phone): 5W/7.5W/10W/15W Earphone(Earphone): 5W Watch(Watch): 3W
Test description:	Phone Battery>98%, =50%and <1% are tested, and the worst is <1%. Earphone Battery>98%, =50%and <1% are tested, and the worst is <1%. Watch Battery>98%, =50%and <1% are tested, and the worst is <1%.

3.2 Test mode

Test Modes:		
Mode 1	Wireless Output (Phone:5W+Watch:3W+Earphone:5W)	Record
Mode 2	Wireless Output (Phone:7.5W+Watch:3W+Earphone:5W)	Record
Mode 3	Wireless Output (Phone:10W+Watch:3W+Earphone:5W)	Record
Mode 4	Wireless Output (Phone:15W+Watch:3W+Earphone:5W)	Record

Note: 1.The appearance of others models listed in the report is different from main-test model H6, but the circuit and the electronic construction do not change, declared by the manufacturer.

Note: 2.The detailed difference about the appearance is that the H6 has a bracket on the back, so the H6 supports two setup: standing and plane. By the pre-scanning of two different setup for the model H6, the plane setup is the worst-case of H6. The report only reflects the worst-case data.

Note: 3.All test modes of the equipment have been evaluated and tested, and the report only reflects the data of the worst mode.

3.3 Block Diagram of EUT Configuration

Conducted Emission

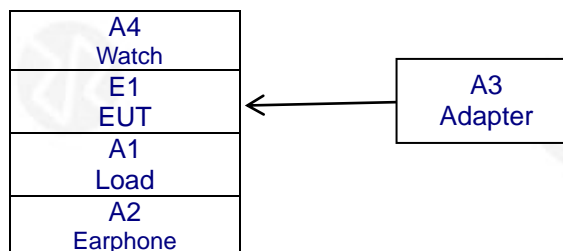



Radiated Emission

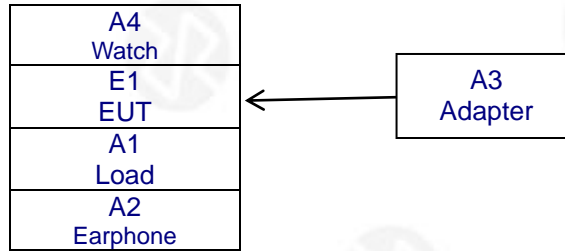

3.4 Test Conditions

Temperature: 23~26°C

Relative Humidity: 54~63 %

3.5 Description Of Support Units (Conducted Mode)

The EUT has been tested as an independent unit together with other necessary accessories or support units. The following support units or accessories were used to form a representative test configuration during the tests.

Item	Equipment	Mfr/Brand	Model/Type No.	Series No.	Note
E1	Wireless Charging Station	/	H6	/	EUT
A1	Load	/	YBZ1.1	/	Auxiliary
A2	Earphone	Apple Inc.	/	/	Auxiliary
A3	Adapter	/	LBE-P2006	/	Auxiliary
A4	Watch	Apple Inc.	/	/	Auxiliary

Item	Shielded Type	Ferrite Core	Length	Note
C1	NO	NO	1.2M	DC cable unshielded

Note:

- (1) The support equipment was authorized by Declaration of Confirmation.
- (2) For detachable type I/O cable should be specified the length in cm in 『Length』 column.
- (3) “YES” is means “shielded” “with core”; “NO” is means “unshielded” “without core”.



3.6 EQUIPMENTS LIST FOR ALL TEST ITEMS

Item	Equipment	Manufacturer	Type No.	Serial No.	Last calibration	Calibrated until
1	Spectrum Analyzer (9kHz-26.5GHz)	KEYSIGHT	9020A	MY55370835	Oct. 28, 2022	Oct. 27, 2023
2	Spectrum Analyzer (10kHz-39.9GHz)	R&S	FSQ	100363	Oct. 28, 2022	Oct. 27, 2023
3	EMI Test Receiver (9kHz-7GHz)	R&S	ESCI7	101169	Oct. 28, 2022	Oct. 27, 2023
4	Bilog Antenna (30MHz-1500MHz)	Schwarzbeck	VULB9168	N/A	Nov. 02, 2022	Nov. 01, 2023
5	Horn Antenna (1GHz-18GHz)	Agilent	AH-118	071145	Nov. 01, 2022	Oct. 31, 2023
6	Horn Antenna (15GHz-40GHz)	A.H.System	SAS-574	588	Oct. 28, 2022	Oct. 27, 2023
7	Loop Antenna	TESEQ	HLA6121	58357	Nov. 01, 2022	Oct. 31, 2023
8	Amplifier (30-1000MHz)	EM Electronics	EM330 Amplifier	060747	Nov. 15, 2022	Nov. 14, 2023
9	Amplifier (1GHz-26.5GHz)	Agilent	8449B	3008A00315	Oct. 28, 2022	Oct. 27, 2023
10	Amplifier (500MHz-40GHz)	全聚达	DLE-161	097	Oct. 28, 2022	Oct. 27, 2023
11	Test Cable	N/A	R-01	N/A	Oct. 28, 2022	Oct. 27, 2023
12	Test Cable	N/A	R-02	N/A	Oct. 28, 2022	Oct. 27, 2023
13	Test Cable	N/A	R-03	N/A	Oct. 28, 2022	Oct. 27, 2023
14	Test Cable	N/A	RF-01	N/A	Oct. 28, 2022	Oct. 27, 2023
15	Test Cable	N/A	RF-02	N/A	Oct. 28, 2022	Oct. 27, 2023
16	Test Cable	N/A	RF-03	N/A	Oct. 28, 2022	Oct. 27, 2023
17	ESG Signal Generator	Agilent	E4421B	N/A	Oct. 21, 2022	Oct. 20, 2023
18	Signal Generator	Agilent	N5182A	N/A	Oct. 21, 2022	Oct. 20, 2023
19	Magnetic Field Probe Tester	Narda	ELT-400	0-0344	Nov. 15, 2022	Nov. 14, 2023
20	Wideband Radio Communication Test	R&S	CMW500	106504	Oct. 28, 2022	Oct. 27, 2023
21	MWRF Power Meter Test system	MW	MW100-RPCB	N/A	Oct. 21, 2022	Oct. 20, 2023
22	D.C. Power Supply	LongWei	TPR-6405D	N/A	\	\
23	EMC Software	Frad	EZ-EMC	Ver.EMC-CON 3A1.1	\	\
24	RF Software	MW	MTS8310	V2.0.0.0	\	\
25	Turntable	MF	MF-7802BS	N/A	\	\
26	Antenna tower	MF	MF-7802BS	N/A	\	\



4. CONDUCTED EMISSION TEST

4.1 CONDUCTED EMISSION MEASUREMENT

Test Requirement:	FCC Part15 C Section 15.207
Test Method:	ANSI C63.10:2013
Test Frequency Range:	150KHz to 30MHz
Receiver setup:	RBW=9KHz, VBW=30KHz, Sweep time=auto

4.1.1 POWER LINE CONDUCTED EMISSION Limits

FREQUENCY (MHz)	Limit (dBuV)		Standard
	Quas -peak	Average	
0.15 -0.5	66 - 56 *	56 - 46 *	FCC
0.50 -5.0	56.00	46.00	FCC
5.0 -30.0	60.00	50.00	FCC

Note:

(1) *Decreases with the logarithm of the frequency.

4.1.2 TEST PROCEDURE

- a. The EUT was placed 0.8 meters from the horizontal ground plane with EUT being connected to the power mains through a line impedance stabilization network (LISN). All other support equipments powered from additional LISN(s). The LISN provide 50 Ohm/ 50uH of coupling impedance for the measuring instrument.
- b. Interconnecting cables that hang closer than 40 cm to the ground plane shall be folded back and forth in the center forming a bundle 30 to 40 cm long.
- c. I/O cables that are not connected to a peripheral shall be bundled in the center. The end of the cable may be terminated, if required, using the correct terminating impedance. The overall length shall not exceed 1 m.
- d. LISN at least 80 cm from nearest part of EUT chassis.
- e. For the actual test configuration, please refer to the related Item –EUT Test Photos.

4.1.3 DEVIATION FROM TEST STANDARD

No deviation



4.1.4 TEST SETUP

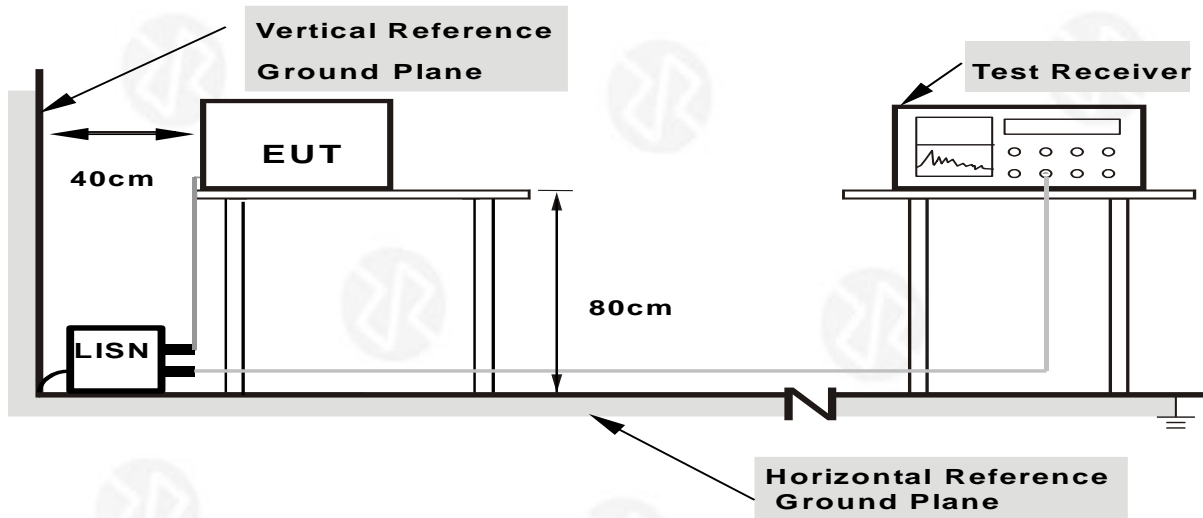

- Note: 1.Support units were connected to second LISN.**
2.Both of LISNs (AMN) are 80 cm from EUT and at least 80 from other units and other metal planes

4.1.5 EUT OPERATING CONDITIONS

The EUT was configured for testing in a typical fashion (as a customer would normally use it). The EUT has been programmed to continuously transmit during test. This operating condition was tested and used to collect the included data.

4.1.6 Test Result



Temperature:	26°C	Relative Humidity:	54%
Pressure:	101kPa	Phase :	L
Test Voltage :	AC 120V/60Hz		

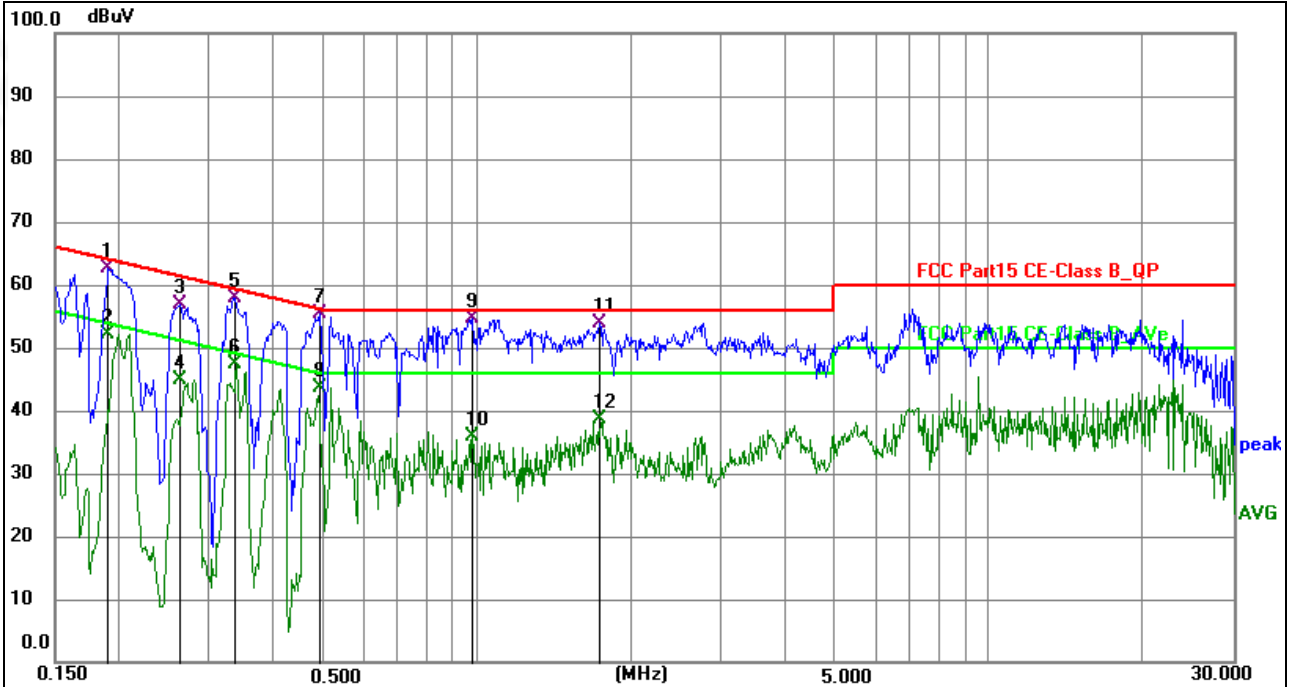

No.	Frequency (MHz)	Reading (dBuV)	Factor (dB)	Level (dBuV)	Limit (dBuV)	Margin (dB)	Detector
1	0.190100	52.58	10.08	62.66	64.03	-1.37	QP
2	0.190100	41.94	10.08	52.02	54.03	-2.01	AVG
3	0.262500	46.73	10.06	56.79	61.35	-4.56	QP
4	0.262500	34.73	10.06	44.79	51.35	-6.56	AVG
5	0.334500	47.85	10.09	57.94	59.34	-1.40	QP
6	0.334500	37.17	10.09	47.26	49.34	-2.08	AVG
7 *	0.491900	45.25	10.08	55.33	56.14	-0.81	QP
8	0.491900	33.64	10.08	43.72	46.14	-2.42	AVG
9	0.982500	44.64	10.07	54.71	56.00	-1.29	QP
10	0.982500	25.92	10.07	35.99	46.00	-10.01	AVG
11	1.737900	43.96	10.02	53.98	56.00	-2.02	QP
12	1.737900	28.59	10.02	38.61	46.00	-7.39	AVG

Notes:

1. An initial pre-scan was performed on the line and neutral lines with peak detector.
2. Quasi-Peak and Average measurement were performed at the frequencies with maximized peak emission.
3. Measurement Level = Reading level + Correct Factor



Temperature:	26°C	Relative Humidity:	54%
Pressure:	101kPa	Phase :	N
Test Voltage :	AC 120V/60Hz		

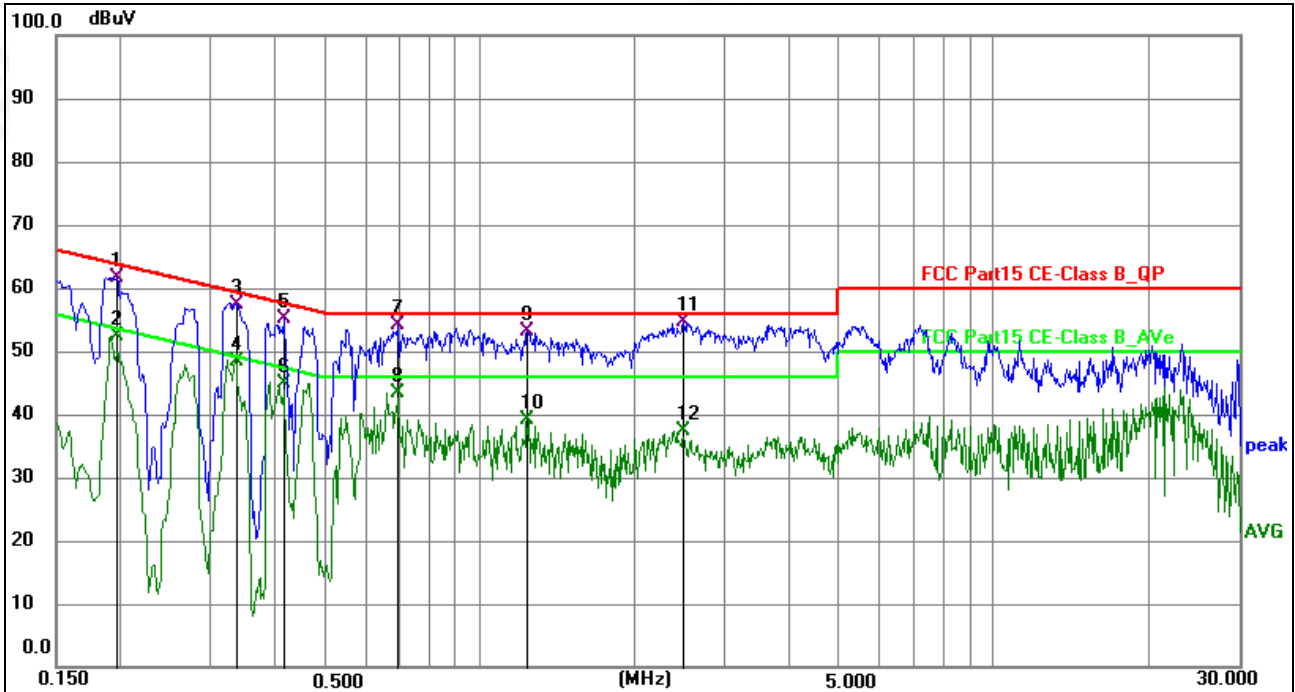

No.	Frequency (MHz)	Reading (dBuV)	Factor (dB)	Level (dBuV)	Limit (dBuV)	Margin (dB)	Detector
1	0.196500	51.67	10.07	61.74	63.76	-2.02	QP
2	0.196500	42.20	10.07	52.27	53.76	-1.49	AVG
3	0.334500	47.28	10.09	57.37	59.34	-1.97	QP
4 *	0.334500	38.36	10.09	48.45	49.34	-0.89	AVG
5	0.415300	45.14	10.10	55.24	57.54	-2.30	QP
6	0.415300	34.88	10.10	44.98	47.54	-2.56	AVG
7	0.694500	43.99	10.06	54.05	56.00	-1.95	QP
8	0.694500	33.37	10.06	43.43	46.00	-2.57	AVG
9	1.239000	43.18	10.05	53.23	56.00	-2.77	QP
10	1.239000	29.08	10.05	39.13	46.00	-6.87	AVG
11	2.494400	44.77	9.96	54.73	56.00	-1.27	QP
12	2.494400	27.46	9.96	37.42	46.00	-8.58	AVG

Notes:

1. An initial pre-scan was performed on the line and neutral lines with peak detector.
2. Quasi-Peak and Average measurement were performed at the frequencies with maximized peak emission.
3. Measurement Level = Reading level + Correct Factor



5. RADIATED EMISSION MEASUREMENT

Test Requirement:	FCC Part15 C Section 15.209				
Test Method:	ANSI C63.10:2013				
Test Frequency Range:	9kHz to 1GHz				
Test site:	Measurement Distance: 3m				
Receiver setup:	Frequency	Detector	RBW	VBW	Value
	9KHz-150KHz	Quasi-peak	200Hz	600Hz	Quasi-peak
	150KHz-30MHz	Quasi-peak	9KHz	30KHz	Quasi-peak
	30MHz-1GHz	Quasi-peak	100KHz	300KHz	Quasi-peak
	Above 1GHz	Peak	1MHz	3MHz	Peak
Peak		1MHz	10Hz	Average	

5.1 Radiated Emission Limits

Limits for frequency below 30MHz

Frequency	Limit (uV/m)	Measurement Distance(m)	Remark
0.009-0.490	2400/F(kHz)	300	Quasi-peak Value
0.490-1.705	24000/F(kHz)	30	Quasi-peak Value
1.705-30	30	30	Quasi-peak Value

Limits for frequency Above 30MHz

Frequency	Limit (dBuV/m @3m)	Remark
30MHz-88MHz	40.00	Quasi-peak Value
88MHz-216MHz	43.50	Quasi-peak Value
216MHz-960MHz	46.00	Quasi-peak Value
960MHz-1GHz	54.00	Quasi-peak Value
Above 1GHz	54.00	Average Value
	74.00	Peak Value



5.2 Anechoic Chamber Test Setup Diagram

(A) Radiated Emission Test-Up Frequency Below 30MHz

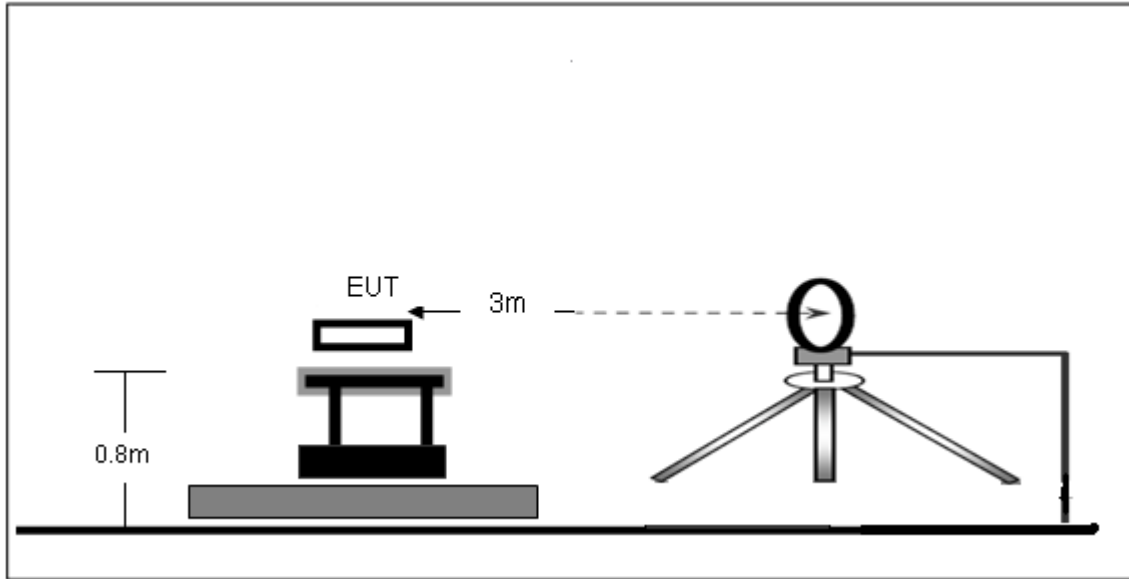

(B) Radiated Emission Test-Up Frequency 30MHz~1GHz

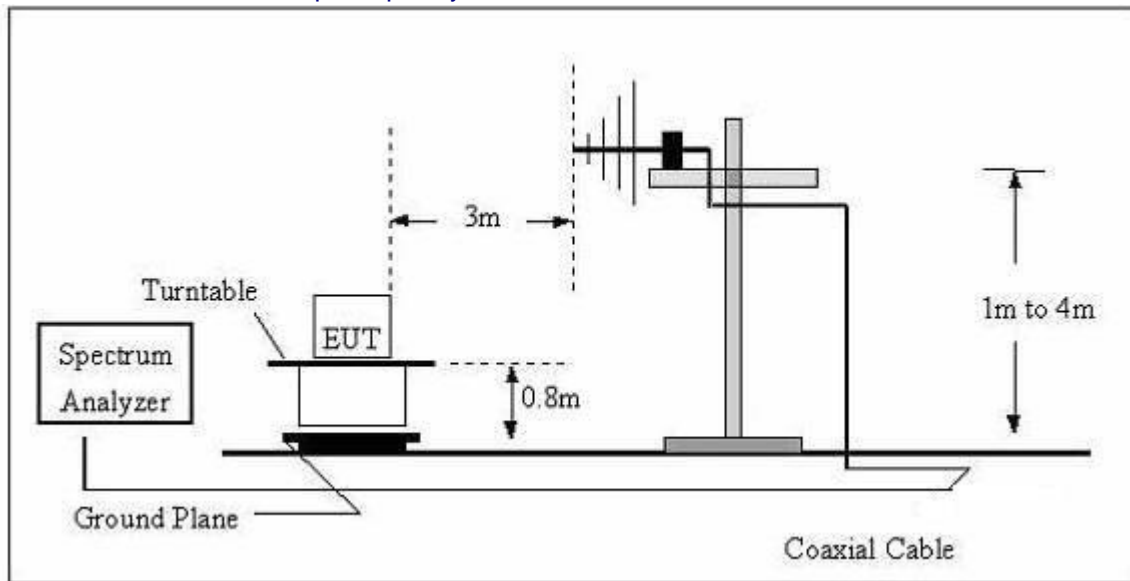

The radiated emission tests were performed in the 3 meters chamber test site, using the setup accordance with the ANSI C63.10-2013. The specification used was the FCC 15.209 and FCC 15.205 limits.

5.3 Test Procedure

The EUT is placed on a turn table which is 0.8 meter above ground. The turn table can rotate 360 degrees to determine the position of the maximum emission level. The EUT is set 3 meters away from the receiving antenna which is mounted on a antenna tower. The antenna can move up and down between 1 to 4 meters to find out the maximum emission level. Broadband antenna (calibrated by dipole antenna) are used as a receiving antenna. Both horizontal and vertical polarization of the antenna are set on measurement.

5.4 Deviation From Test Standard

No deviation



5.5 Test Result

Measurement data:

Note: Limit dBuV/m @3m = Limit dBuV/m @300m+ 80

Limit dBuV/m @3m = Limit dBuV/m @30m + 40

9 kHz~30 MHz

Frequency (MHz)	Meter Reading (dBμV)	Factor (dB)	Emission Level (dBμV/m)	Limits (dBμV/m)	Margin (dB)	Detector Type
0.1267	57.84	19.12	76.96	105.57	-28.61	AV
0.1900	48.64	19.26	67.90	102.04	-34.14	AV
0.3220	30.70	19.29	49.99	97.45	-47.46	AV
0.3818	39.61	19.30	58.91	95.97	-37.06	QP
0.4638	31.63	19.33	50.96	94.28	-43.32	QP
0.5725	24.09	19.35	43.44	72.45	-29.01	QP

Note:

Pre-scan in the all of mode, the worst case in of was recorded.

Factor = antenna factor + cable loss – pre-amplifier.

Margin = Emission Level- Limit.



30MHz-1GHz

Temperature:	26°C	Relative Humidity:	54%
Pressure:	101 kPa	Polarization:	Horizontal
Test Voltage:	AC 120V/60Hz		

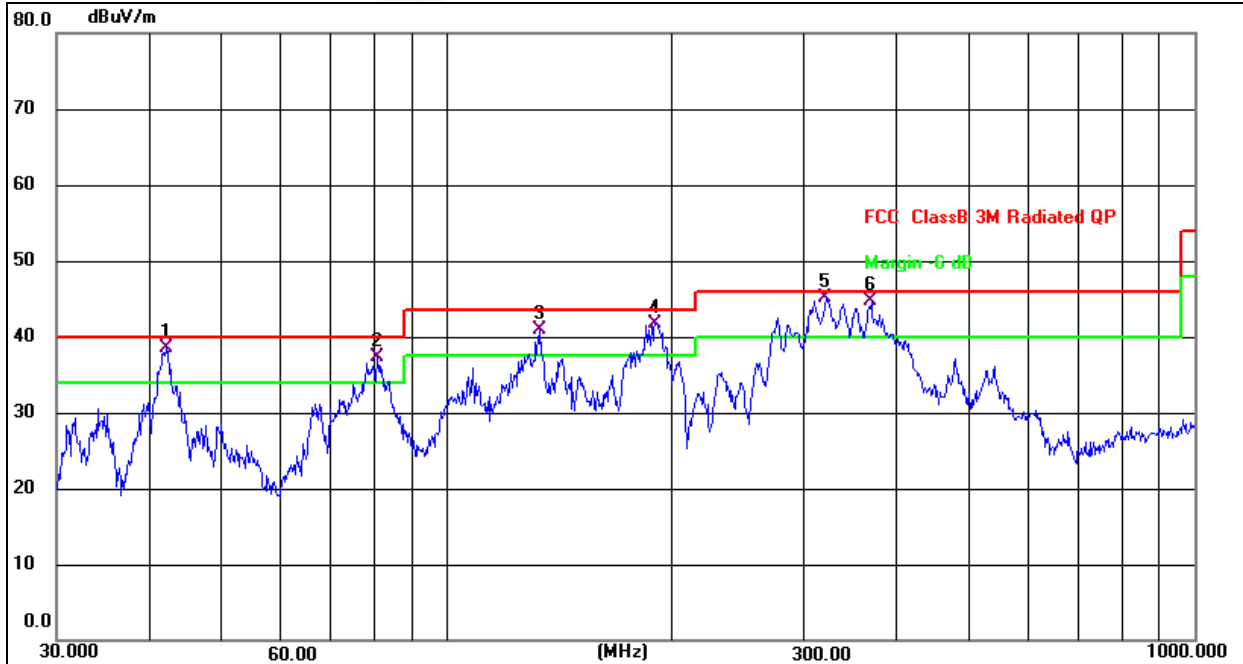

No.	Frequency (MHz)	Reading (dBuV)	Factor (dB/m)	Level (dBuV/m)	Limit (dBuV/m)	Margin (dB)	Detector
1 !	42.0065	52.57	-14.11	38.46	40.00	-1.54	QP
2 !	80.6440	56.22	-18.88	37.34	40.00	-2.66	QP
3 !	133.1510	55.78	-14.95	40.83	43.50	-2.67	QP
4 !	189.7384	57.69	-16.04	41.65	43.50	-1.85	QP
5 *	321.0605	57.58	-12.49	45.09	46.00	-0.91	QP
6 !	369.4045	55.77	-11.01	44.76	46.00	-1.24	QP



Temperature:	26°C	Relative Humidity:	54%
Pressure:	101kPa	Polarization:	Vertical
Test Voltage:	AC 120V/60Hz		

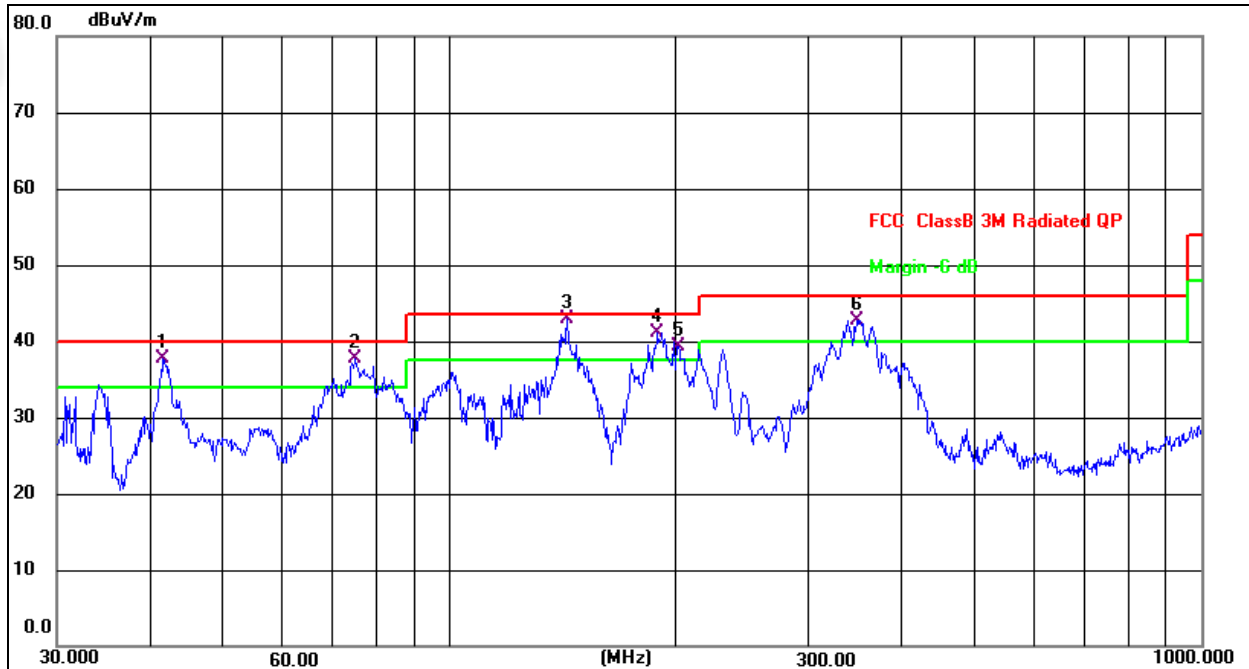

No.	Frequency (MHz)	Reading (dBuV)	Factor (dB/m)	Level (dBuV/m)	Limit (dBuV/m)	Margin (dB)	Detector
1 !	41.5670	51.71	-14.08	37.63	40.00	-2.37	QP
2 !	74.9191	55.31	-17.53	37.78	40.00	-2.22	QP
3 *	143.3258	56.93	-14.09	42.84	43.50	-0.66	QP
4 !	189.0741	57.16	-15.98	41.18	43.50	-2.32	QP
5 !	201.3930	55.95	-16.68	39.27	43.50	-4.23	QP
6 !	348.0274	54.45	-11.71	42.74	46.00	-3.26	QP

Remarks:

1. Final Level = Receiver Read level + Antenna Factor + Cable Loss – Preamplifier Factor
2. The emission levels of other frequencies are very lower than the limit and not show in test report.



6. BANDWIDTH TEST

6.1 Limits

1. Set RBW = 300Hz.
2. Set the video bandwidth (VBW) $\geq 3 \times$ RBW.
3. Detector = Peak.
4. Trace mode = max hold.
5. Sweep = auto couple.
6. Allow the trace to stabilize.
7. Measure the maximum width of the emission that is constrained by the frequencies associated with the two outermost amplitude points (upper and lower frequencies) that are attenuated by 20 dB relative to the maximum level measured in the fundamental emission.

6.2 Test Setup



6.3 Test Result



Phone:

Temperature:	26 °C	Relative Humidity:	54%
Pressure:	101kPa		

Frequency (KHz)	20dB bandwidth (Hz)	Result
128.115	809.20	Pass

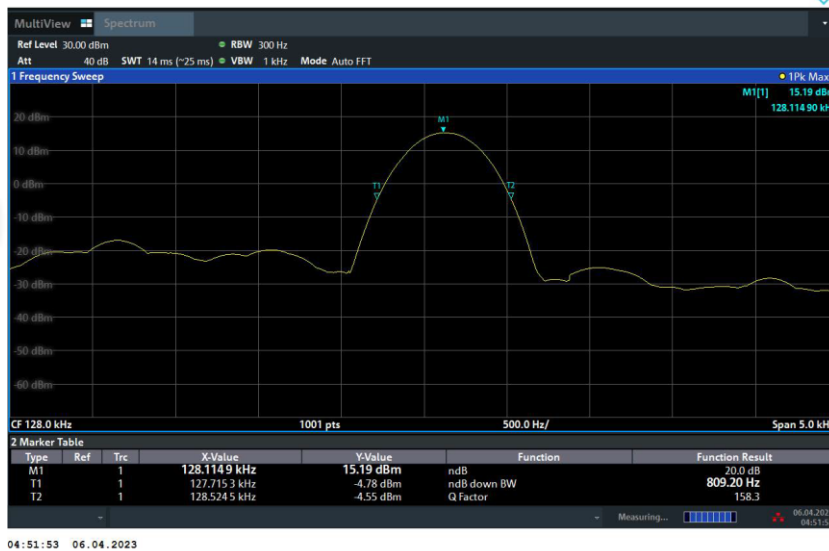

Earphone:

Temperature:	26 °C	Relative Humidity:	54%
Pressure:	101kPa		

Frequency (KHz)	20dB bandwidth (Hz)	Result
123.085	814.20	Pass

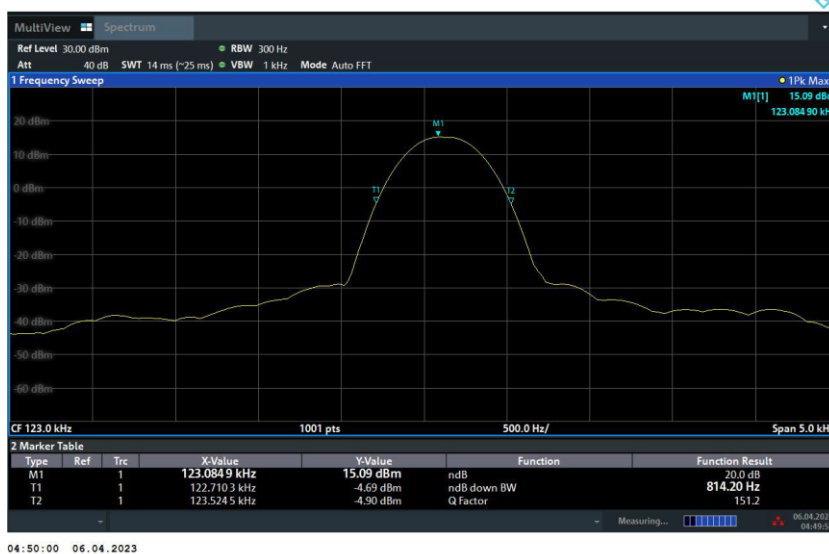



Watch:

Temperature:	26 °C	Relative Humidity:	54%
Pressure:	101kPa		

Frequency (KHz)	20dB bandwidth (Hz)	Result
328.25	819.20	Pass

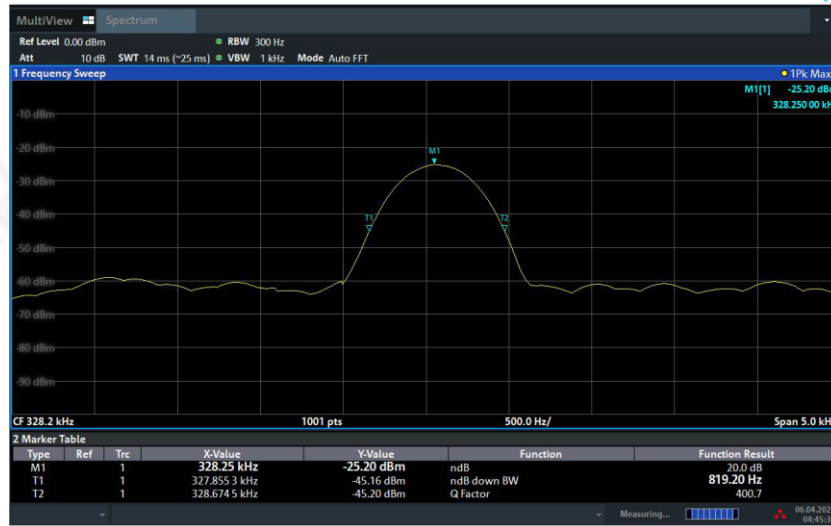



7. ANTENNA REQUIREMENT

Standard requirement:	FCC Part15 C Section 15.203
15.203 requirement: An intentional radiator shall be designed to ensure that no antenna other than that furnished by the responsible party shall be used with the device. The use of a permanently attached antenna or of an antenna that uses a unique coupling to the intentional radiator, the manufacturer may design the unit so that a broken antenna can be replaced by the user, but the use of a standard antenna jack or electrical connector is prohibited.	
EUT Antenna:	
The antenna is Loop antenna, the best case gain of the antennas is 0dBi, reference to the appendix II for details	



8. TEST SETUP PHOTO

Reference to the appendix I for details.

9. EUT CONSTRUCTIONAL DETAILS

Reference to the appendix II for details.

******* END OF REPORT *******