



TEST REPORT	
Report Number.:	90051-24-72-24-PP001
Date of issue	2023-12-28
Prepared by (+signature)	Pale <i>Pale Cai</i>
Tested by (+signature).....:	Duke <i>Duke Chen</i>
Approved by (+signature)	Jason <i>Jason gao</i>
Testing Laboratory name	SLG-CPC Testlaboratory Co., Ltd.
Address	No. 11, Wu Song Road, Dongcheng District, Dongguan, Guangdong Province, China 523117
Applicant's name.....:	CG Mobile SAS
Address	39 rue de Courcelles 75008 PARIS
Manufacturer's name	Guangzhou Rikiki Tech CO., LTD
Address	B2 of Greenland Central Plaza, Huangpu District, GZ
Factory's name	Guangzhou Rikiki Tech CO., LTD
Address	B2 of Greenland Central Plaza, Huangpu District, GZ
Standard(s).....:	FCC 47 CFR Part 15, Subpart C
Test item description	Wireless earbuds
Trade Mark.....:	N/A
Model/Type reference.....:	Y113S, GUTWSHDGKEEK, GUTWSHDGKEED, GUTWSHDGKEEP, GUTWSHDGKEEU, GUTWSHDGKTEK, GUTWSHDGKTED, GUTWSHDGKTEP, GUTWSHDGKTEU, HKTWSHDGKEP, HKTWSHDGKEU, HKTWSHDGKEQ, HKTWSHDGKEK, HELLO KITTY TWS
FCC ID.....:	2A7J2HKTWS
Date of receipt of test item ...:	2023-12-01
Date (s) of performance of test	2023-12-12 to 2023-12-27
Summary of Test Results	Pass
The Summary of Test Results based on a technical opinion belongs to the standard(s).	
General disclaimer:	
This report shall not be reproduced except in full, without the written approval of SLG-CPC Testlaboratory Co., Ltd. The test results in the report only apply to the tested sample.	

TABLE OF CONTENTS

1	EUT TECHNICAL DESCRIPTION.....	4
2	SUMMARY OF TEST RESULT.....	5
3	TEST METHODOLOGY	6
3.1	GENERAL DESCRIPTION OF APPLIED STANDARDS	6
3.2	MEASUREMENT EQUIPMENT USED	6
3.3	DESCRIPTION OF TEST MODES.....	7
4	FACILITIES AND ACCREDITATIONS	8
4.1	FACILITIES.....	8
4.2	LABORATORY ACCREDITATIONS AND LISTINGS	8
5	TEST SYSTEM UNCERTAINTY.....	9
6	SETUP OF EQUIPMENT UNDER TEST	10
6.1	RADIO FREQUENCY TEST SETUP 1	10
6.2	RADIO FREQUENCY TEST SETUP 2	10
6.3	CONDUCTED EMISSION TEST SETUP.....	12
6.4	BLOCK DIAGRAM CONFIGURATION OF TEST SYSTEM	13
6.5	SUPPORT EQUIPMENT	13
7	TEST REQUIREMENTS.....	14
7.1	20DB BANDWIDTH	14
7.2	CARRIER FREQUENCY SEPARATION.....	20
7.3	NUMBER OF HOPPING FREQUENCIES	26
7.4	AVERAGE TIME OF OCCUPANCY (DWELL TIME).....	29
7.5	MAXIMUM PEAK CONDUCTED OUTPUT POWER.....	32
7.6	CONDUCTED SUPRIOUS EMISSION.....	38
7.7	RADIATED SPURIOUS EMISSION	45
7.8	CONDUCTED EMISSION TEST.....	59
7.9	ANTENNA APPLICATION	60

Modified Information

Report No.	Revision Data	Summary
90051-24-72-24-PP001	2023-12-28	Original Version

1 EUT TECHNICAL DESCRIPTION

Characteristics	Description
Product	Wireless earbuds
Model Number	Y113S, GUTWSHDGKEEK, GUTWSHDGKEED, GUTWSHDGKEEP, GUTWSHDGKEEU, GUTWSHDGKTEK, GUTWSHDGKTED, GUTWSHDGKTEP, GUTWSHDGKTEU, HKTWSHDGKEP, HKTWSHDGKEU, HKTWSHDGKEQ, HKTWSHDGKEK, HELLO KITTY TWS (All models are identical except for the model name and color; All tests were performed on model Y113S)
Device Type	Bluetooth V5.3
Data Rate	1Mbps for BT V5.3 GFSK modulation 2Mbps for BT V5.3 pi/4-DQPSK modulation 3Mbps for BT V5.3 8DPSK modulation
Modulation:	GFSK modulation for BT V5.3 (1Mbps) pi/4-DQPSK modulation for BT V5.3 (2Mbps) 8DPSK modulation for BT V5.3 (3Mbps)
Operating Frequency Range(s):	2402-2480MHz
Number of Channels:	79 channels
Transmit Power Max:	0.22 dBm
Antenna Type	Chip Antenna
Antenna Gain	2.7 dBi
Power supply	Input: DC 5V Battery Capacity: 3.7V 30mAh Charging box: DC 3.7V 230mAh
Temperature Range:	-20°C ~ +55°C

Note: for more details, please refer to the User's manual of the EUT.

2 SUMMARY OF TEST RESULT

FCC Part Clause	Test Parameter	Verdict	Remark
15.247(a)(1)	20 dB Bandwidth	PASS	
15.247(a)(1)	Carrier Frequency Separation	PASS	
15.247(a)(1)	Number of Hopping Frequencies	PASS	
15.247(a)(1)	Average Time of Occupancy (Dwell Time)	PASS	
15.247(b)(1)	Maximum Peak Conducted Output Power	PASS	
15.247(c)	Conducted Spurious Emissions	PASS	
15.247(d) 15.209	Radiated Spurious Emissions	PASS	
15.207	Conducted Emission	N/A	
15.203	Antenna Application	PASS	
15.247 (a) (1)/g/h	Frequency Hopping System	PASS	
NOTE1: N/A (Not Applicable) NOTE2: According to FCC KDB 558074 D01 15.247 Meas Guidance v05r02, the report use radiated measurements in the restricted frequency bands. In addition, the radiated test is also performed to ensure the emissions emanating from the device cabinet also comply with the applicable limits.			

RELATED SUBMITTAL(S) / GRANT(S):

This submittal(s) (test report) is intended for FCC ID: 2A7J2HKTWS filing to comply with Section 15.247 of the FCC Part 15, Subpart C Rules.

3 TEST METHODOLOGY

3.1 GENERAL DESCRIPTION OF APPLIED STANDARDS

According to its specifications, the EUT must comply with the requirements of the following standards:

FCC 47 CFR Part 15, Subpart C

FCC KDB 558074 D01 15.247 Meas Guidance v05r02

3.2 MEASUREMENT EQUIPMENT USED

Equipment	Manufacturer	Model	S/N	Last Cal.	DUE Cal.
RF Connected Test					
Vector Signal Generator	Rohde & Schwarz	SMBV100B(6G)	101166	2023/06/04	1 year
Analog Signal Generator	Rohde & Schwarz	SMB100A(40G)	181333	2023/08/04	1 year
Signal Analyzer	Rohde & Schwarz	FSV40	101527	2023/03/29	1 year
Power Analyzer	Rohde & Schwarz	OSP-B157W8	N/A	2023/06/02	1 year
Wideband Radio Communication Tester	R&S	CMW270	101985	2023/06/16	1 year
Wideband Radio Communication Tester	Rohde & Schwarz	CMW500	166898	2023/06/16	1 year
Temperature&Humidity test chamber	ESPEC	VC 4018	/	2023/03/29	1 year
Radiated Emission Test					
EMI Test Receiver	KEYSIGHT	N9010A	MY56070465	2023/12/05	1 year
EMI Test Receiver	Rohde & Schwarz	FSV40	101511	2023/03/29	1 year
Bilog Antenna	Schwarzbeck	VULB 9163	01335	2023/04/21	3 year
Broadband Antenna	Schwarzbeck	9162	139	2022/03/22	3 year
Power Amplifier	EMEC	EM330	060676	2022/12/07	3 year
Cable	Tuyue	F4309	L-400-NmNm-12000	2022/12/07	2 year
Horn Antenna	Schwarzbeck	BBHA9120D	1779	2022/04/21	3 year
Horn Antenna	Schwarzbeck	BBHA9170	00954	2022/09/13	3 year
Power Amplifier	Rohde & Schwarz	SCU-18F	180118	2022/04/21	3 year
Power Amplifier	Rohde & Schwarz	SCU40A	100499	2023/06/21	3 year
Active Loop Antenna	ETS LINDGREN	6512	41623	2022/04/23	3 year
Test Software	Farad	EZ-EMC	Ver.CPC-3A1	/	/
Conducted Emission Test					
LISN	Schwarzbeck	NSLK 8127	8127-892	2023/03/21	1 year
LISN	Schwarzbeck	NSLK 8127	8127-437	2023/07/07	1 year
EMI Test Receiver	R&S	ESR3	102124	2023/12/05	1 year
Triple loop	R&S	HM020	834206/006	2022/12/07	2 year
Pulse Limiter	R&S	ESH3-Z2	357.8810.52	2023/12/05	1 year
Test Software	Farad	EZ-EMC	Ver.CPC-3A1	/	/

3.3 DESCRIPTION OF TEST MODES

The EUT has been tested under its typical operating condition.

The EUT configuration for testing is installed on RF field strength measurement to meet the Commissions requirement and operating in a manner which intends to maximize its emission characteristics in a continuous normal application.

The Transmitter was operated in the normal operating mode. The TX frequency was fixed which was for the purpose of the measurements.

Test of channel included the lowest and middle and highest frequency to perform the test, then record on this report.

Those data rates (1Mbps for Bluetooth V5.3 GFSK modulation; 2Mbps for Bluetooth V5.3 pi/4-DQPSK modulation; 3Mbps for Bluetooth V5.3 8DPSK modulation) were used for all test.

Pre-defined engineering program for regulatory testing used to control the EUT for staying in continuous transmitting and receiving mode is programmed.

Frequency and Channel list for Bluetooth V5.3

Channel	Frequency (MHz)	Channel	Frequency (MHz)	Channel	Frequency (MHz)
0	2402	39	2441
1	2403	40	2442	76	2478
2	2404	41	2443	77	2479
...	78	2480

Note: $f_c = 2402\text{MHz} + (k-1) \times 1\text{MHz}$ $k=1$ to 79

Test Frequency and channel for Bluetooth V5.3

Lowest Frequency		Middle Frequency		Highest Frequency	
Channel	Frequency (MHz)	Channel	Frequency (MHz)	Channel	Frequency (MHz)
0	2402	39	2441	78	2480

4 FACILITIES AND ACCREDITATIONS

4.1 FACILITIES

All measurement facilities used to collect the measurement data are located at

No. 11, Wu Song Road, Dongcheng District, Dongguan, Guangdong Province, China 523117

The sites are constructed in conformance with the requirements of ANSI C63.4, ANSI C63.10 and CISPR Publication 32.

4.2 LABORATORY ACCREDITATIONS AND LISTINGS

Site Description

EMC Lab. : Accredited by ISED, October 31 2023
CAB identifier: CN0126
Company Number: 27767

Accredited by A2LA, October 31 2023
The Certificate Registration Number is 6325.01

Accredited by FCC
Designation Number: CN1287
Test Firm Registration Number: 394054

Name of Firm : SLG-CPC Testlaboratory Co., Ltd.
Site Location : No. 11, Wu Song Road, Dongcheng District, Dongguan,
Guangdong Province, China 523117

5 TEST SYSTEM UNCERTAINTY

The following measurement uncertainty levels have been estimated for tests performed on the apparatus:

Parameter	Uncertainty
Radio Frequency	$\pm 1 \times 10^{-5}$
Maximum Peak Output Power Test	$\pm 1.0\%$
Conducted Emissions Test	$\pm 3.08\text{dB}$
Radiated Emission Test	$\pm 3.46\text{dB}$ (Below 30MHz)
	$\pm 4.60\text{dB}$ (Below 1GHz)
	$\pm 4.48\text{dB}$ (Above 1GHz)
Power Density	$\pm 0.9\%$
Occupied Bandwidth Test	$\pm 2.3\%$
Band Edge Test	$\pm 1.2\%$
Antenna Port Emission	$\pm 3\text{dB}$
Temperature	$\pm 3.2\%$
Humidity	$\pm 2.5\%$

Measurement Uncertainty for a level of Confidence of 95%

6 SETUP OF EQUIPMENT UNDER TEST

6.1 RADIO FREQUENCY TEST SETUP 1

The Bluetooth V5.3 component's antenna ports(s) of the EUT are connected to the measurement instrument per an appropriate attenuator. The EUT is controlled by PC/software to emit the specified signals for the purpose of measurements.

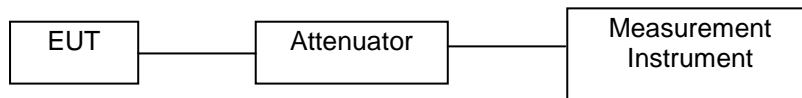

6.2 RADIO FREQUENCY TEST SETUP 2

The test site semi-anechoic chamber has met the requirement of NSA tolerance 4 dB according to the standards: ANSI C63.10. The test distance is 3m. The setup is according to the requirements in Section 13.1.4.1 of ANSI C63.10-2013 and CAN/CSA-CEI/IEC CISPR 32.

Below 30MHz:

The EUT is placed on a turntable 0.8meters above the ground in the chamber, 3 meter away from the antenna (loop antenna). The Antenna should be positioned with its plane vertical at the specified distance from the EUT and rotated about its vertical axis for maximum response at each azimuth about the EUT. The center of the loop shall be 1 m above the ground. For certain applications, the loop antenna plane may also need to be positioned horizontally at the specified distance from the EUT.

Above 30MHz:

The EUT is placed on a turntable 0.8meters above the ground in the chamber, 3 meter away from the antenna. The maximal emission value is acquired by adjusting the antenna height, polarisation and turntable azimuth. Normally, the height range of antenna is 1 m to 4 m, the azimuth range of turntable is 0° to 360°, and the receive antenna has two polarizations Vertical (V) and Horizontal (H).

Above 1GHz:

(Note: the FCC's permission to use 1.5m as an alternative per TCBC Conf call of Dec. 2, 2014.)

The EUT is placed on a turntable 1.5 meters above the ground in the chamber, 3 meter away from the antenna. The maximal emission value is acquired by adjusting the antenna height, polarisation and turntable azimuth. Normally, the height range of antenna is 1 m to 4 m, the azimuth range of turntable is 0° to 360°, and the receive antenna has two polarizations Vertical (V) and Horizontal (H).

(a) Radiated Emission Test Set-Up, Frequency Below 30MHz

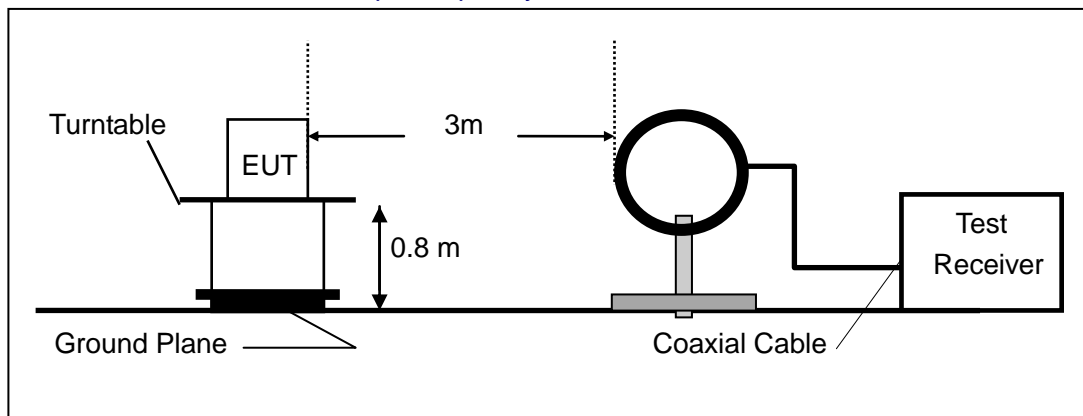

(b) Radiated Emission Test Set-Up, Frequency Below 1000MHz

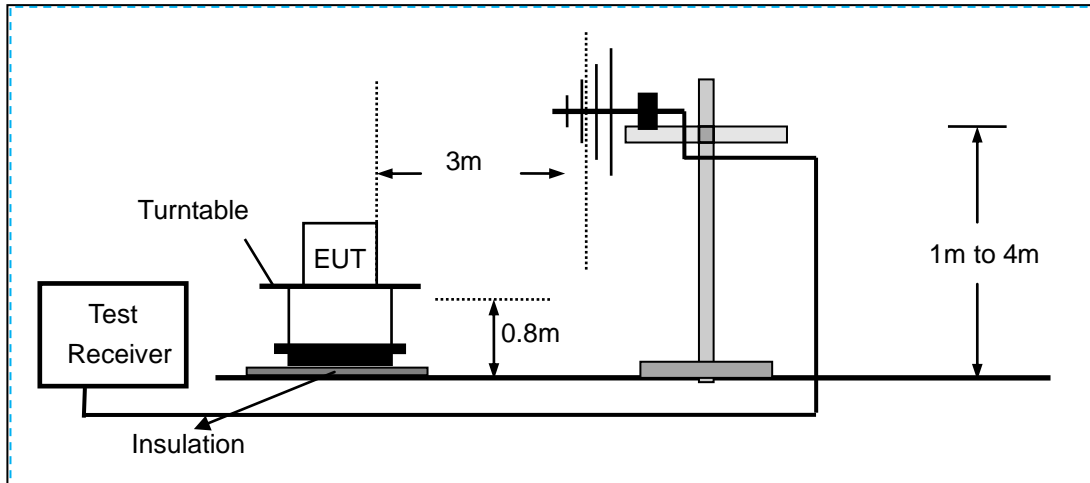

(c) Radiated Emission Test Set-Up, Frequency above 1000MHz

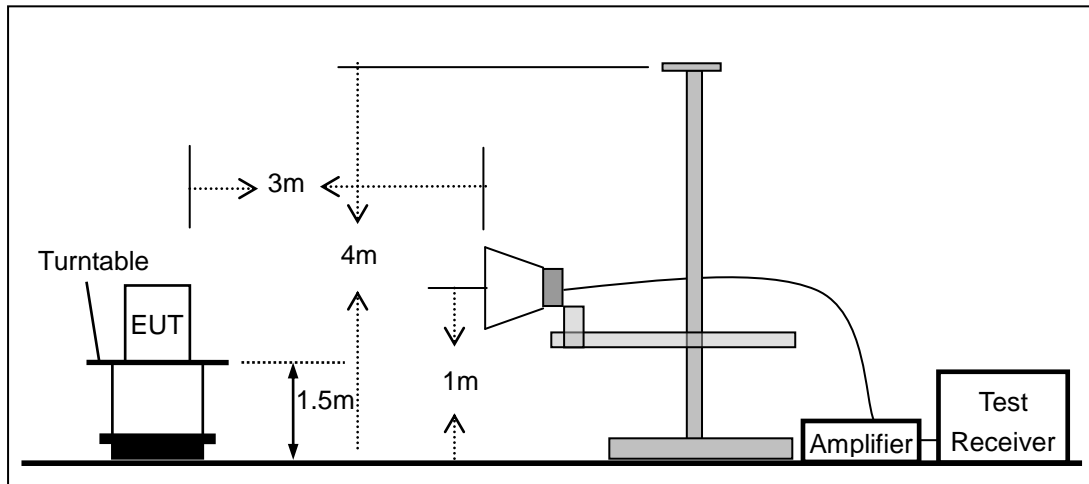

6.3 CONDUCTED EMISSION TEST SETUP

The mains cable of the EUT (Perfect Share Mini) must be connected to LISN. The LISN shall be placed 0.8m from the boundary of EUT and bonded to a ground reference plane for LISN mounted on top of the ground reference plane. This distance is between the closest points of the LISN and the EUT. All other units of the EUT and associated equipment shall be at least 0.8m from the LISN.

Ground connections, where required for safety purposes, shall be connected to the reference ground point of the LISN and, where not otherwise provided or specified by the manufacturer, shall be of same length as the mains cable and run parallel to the mains connection at a separation distance of not more than 0.8m.

According to the requirements in Section 13.1.4.1 of ANSI C63.10-2013 Conducted emissions from the EUT measured in the frequency range between 0.15 MHz and 30 MHz using CISPR Quasi-Peak and average detector mode.

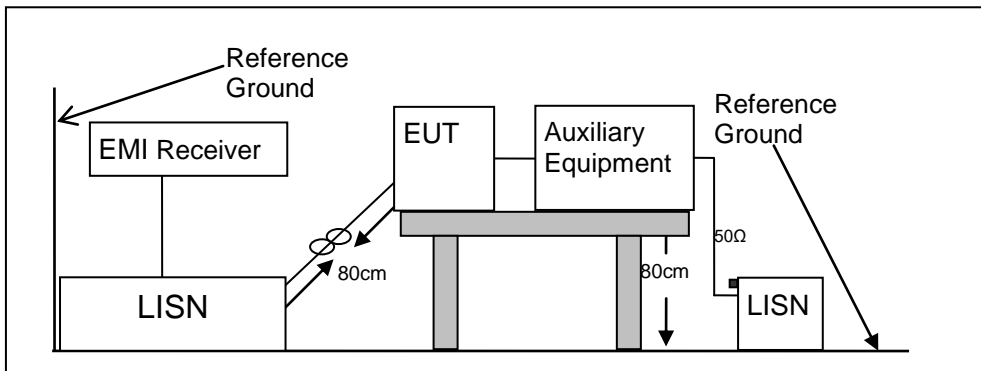

6.4 BLOCK DIAGRAM CONFIGURATION OF TEST SYSTEM

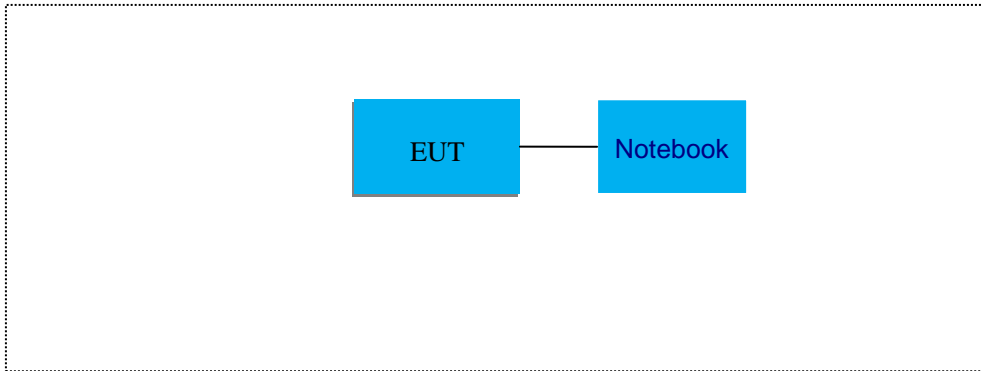

6.5 SUPPORT EQUIPMENT

EUT Cable List and Details			
Cable Description	Length (m)	Shielded/Unshielded	With / Without Ferrite

Auxiliary Cable List and Details			
Cable Description	Length (m)	Shielded/Unshielded	With / Without Ferrite

Auxiliary Equipment List and Details			
Description	Manufacturer	Model	Serial Number
Notebook	Lenovo	WEI6	MP1XHYV7

Notes:

1. All the equipment/cables were placed in the worst-case configuration to maximize the emission during the test.
2. Grounding was established in accordance with the manufacturer's requirements and conditions for the intended use.

7 TEST REQUIREMENTS

7.1 20DB BANDWIDTH

7.1.1 Applicable Standard

According to FCC Part 15.247(a)(1) and KDB 558074 D01 15.247 MEAS GUIDANCE v05r02

7.1.2 Conformance Limit

No limit requirement.

7.1.3 Test Configuration

Test according to clause 6.1 radio frequency test setup 1

7.1.4 Test Procedure

The EUT was operating in Bluetooth V5.3 mode and controlled its channel. Printed out the test result from the spectrum by hard copy function.

The RF output of EUT was connected to the spectrum analyzer by RF cable and attenuator. The path loss was compensated to the results for each measurement.

Set to the maximum power setting and enable the EUT transmit continuously

Set RBW = 30 kHz.

Set the video bandwidth (VBW) =100 kHz.

Set Span= approximately 2 to 3 times the 20 dB bandwidth

Set Detector = Peak.

Set Trace mode = max hold.

Set Sweep = auto couple.

The EUT should be transmitting at its maximum data rate. Allow the trace to stabilize. Use the marker-to-peak function to set the marker to the peak of the emission. Use the marker-delta function to measure 20 dB down one side of the emission. Reset the markerdelta function, and move the marker to the other side of the emission, until it is (as close as possible to) even with the reference marker level. The marker-delta reading at this point is the 20 dB bandwidth of the emission.

If this value varies with different modes of operation (e.g., data rate, modulation format, etc.), repeat this test for each variation.

Measure and record the results in the test report.

Test Results

Temperature:	26° C
Relative Humidity:	54%
ATM Pressure:	1011 mbar

Modulation Mode	Channel Number	Channel Frequency (MHz)	Measurement Bandwidth (MHz)	Limit (MHz)	Verdict
GFSK	00	2402	0.998	N/A	PASS
	39	2441	1.057	N/A	PASS
	78	2480	1.033	N/A	PASS
pi/4-DQPSK	00	2402	1.306	N/A	PASS
	39	2441	1.313	N/A	PASS
	78	2480	1.302	N/A	PASS
8DPSK	00	2402	1.306	N/A	PASS
	39	2441	1.283	N/A	PASS
	78	2480	1.293	N/A	PASS

Note: N/A (Not Applicable)

Test Model 20dB Bandwidth
 Bluetooth V5.3
 Channel 0: 2402MHz GFSK Modulation

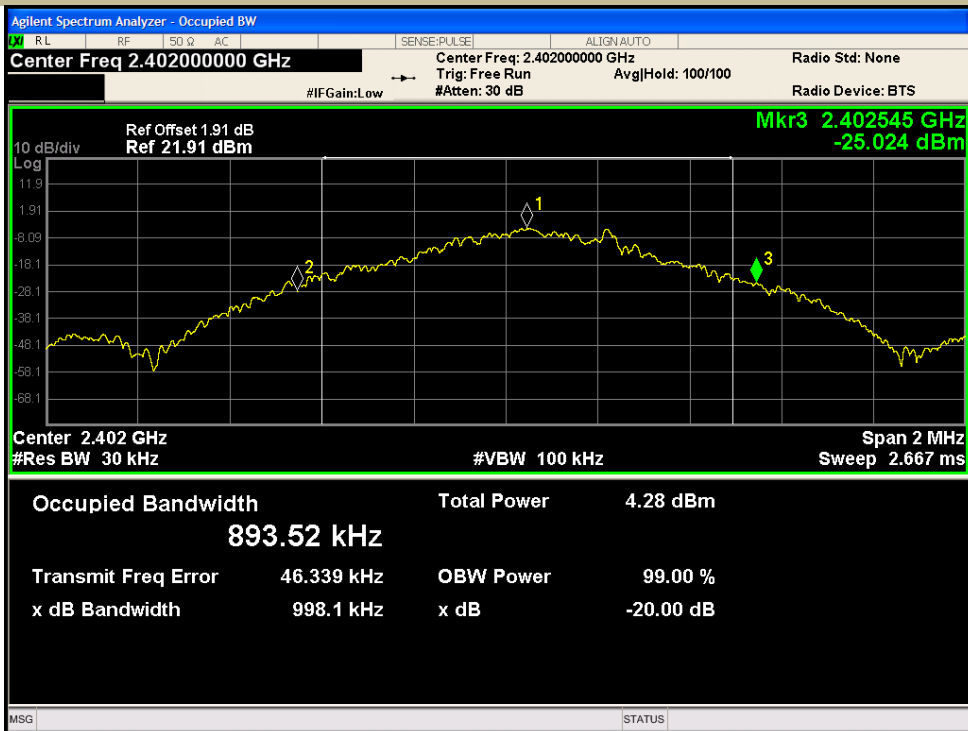

Test Model 20dB Bandwidth
 Bluetooth V5.3
 Channel 39: 2441MHz GFSK Modulation

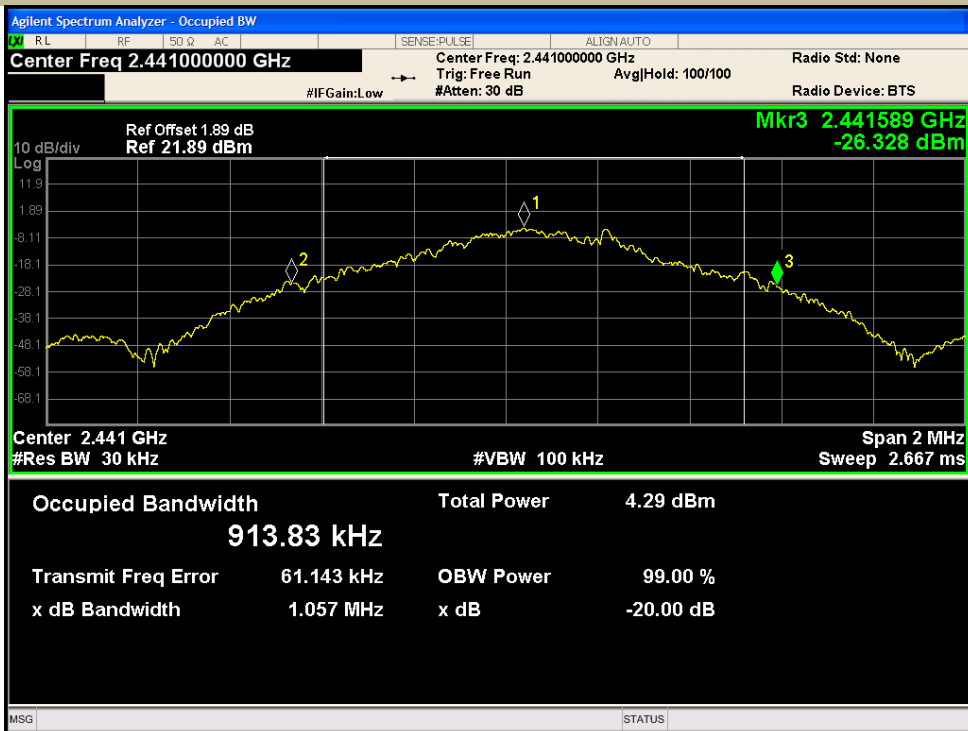

Test Model 20dB Bandwidth
Bluetooth V5.3
Channel 78: 2480MHz GFSK Modulation

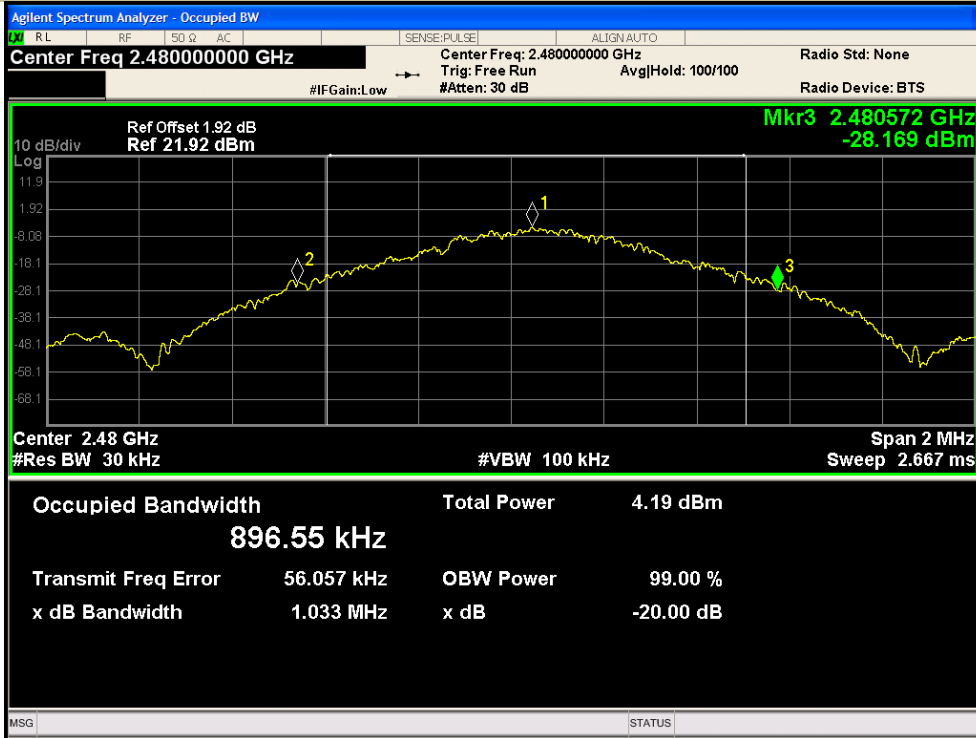

Test Model 20dB Bandwidth
Bluetooth V5.3
Channel 0: 2402MHz pi/4-DQPSK Modulation

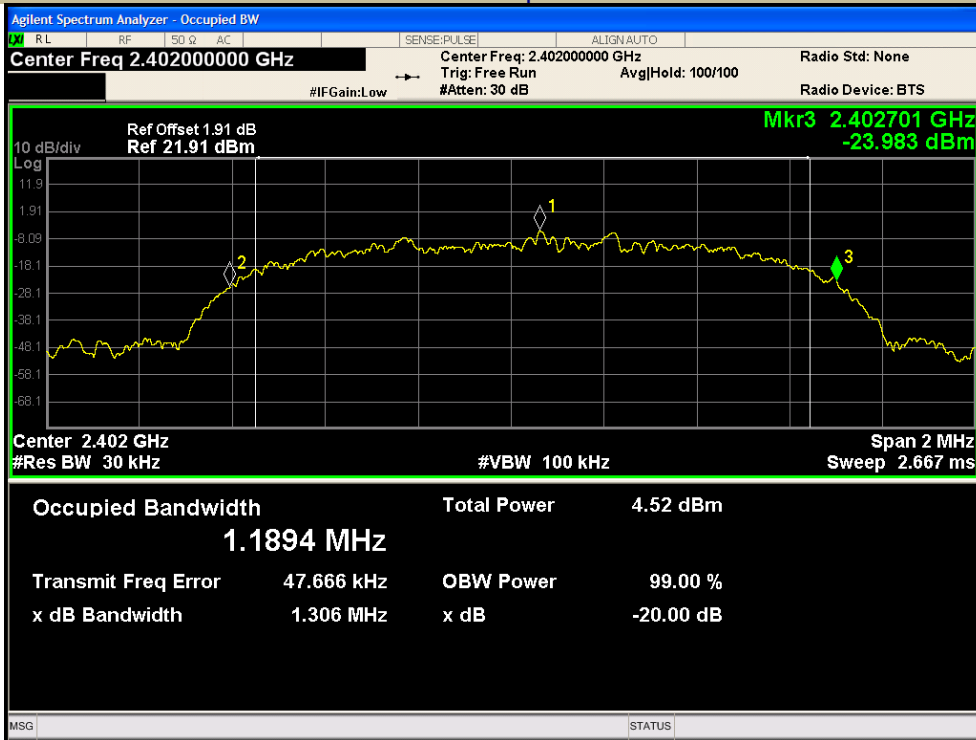

Test Model 20dB Bandwidth
 Bluetooth V5.3
 Channel 39: 2441MHz pi/4-DQPSK Modulation

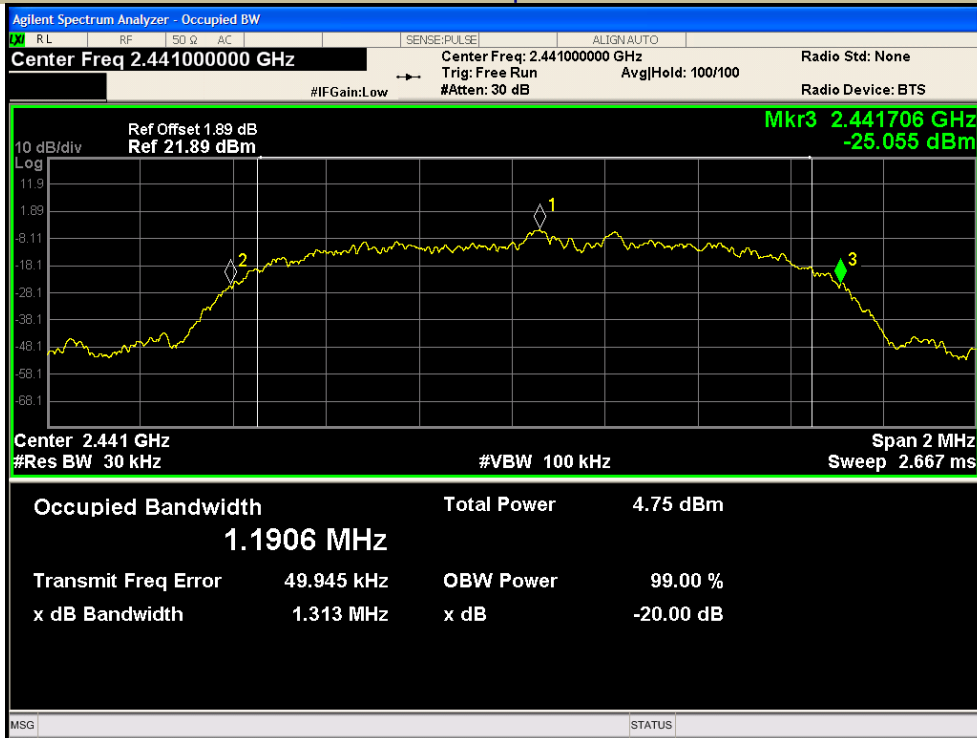

Test Model 20dB Bandwidth
 Bluetooth V5.3
 Channel 78: 2480MHz pi/4-DQPSK Modulation

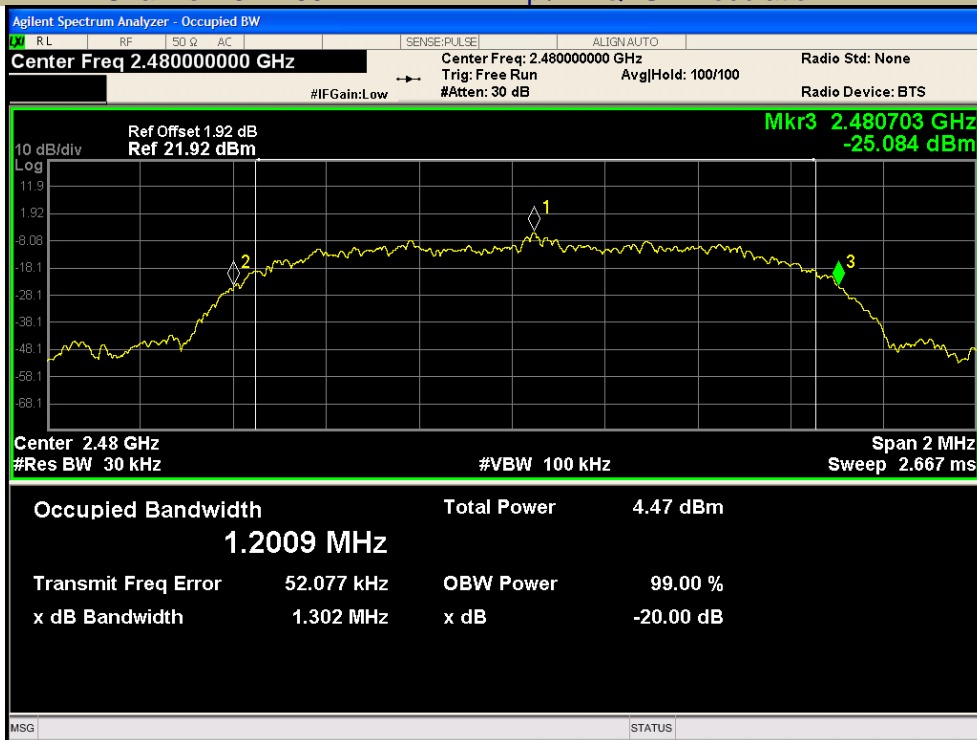

Test Model 20dB Bandwidth
Bluetooth V5.3
Channel 0: 2402MHz 8DPSK Modulation

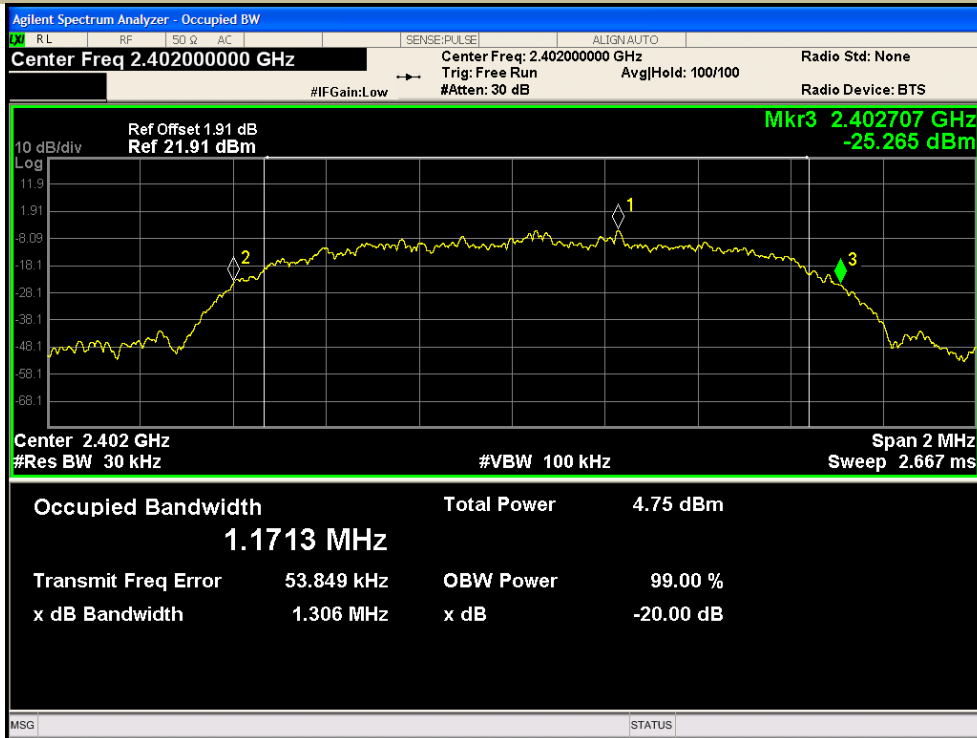

Test Model 20dB Bandwidth
Bluetooth V5.3
Channel 39: 2441MHz 8DPSK Modulation

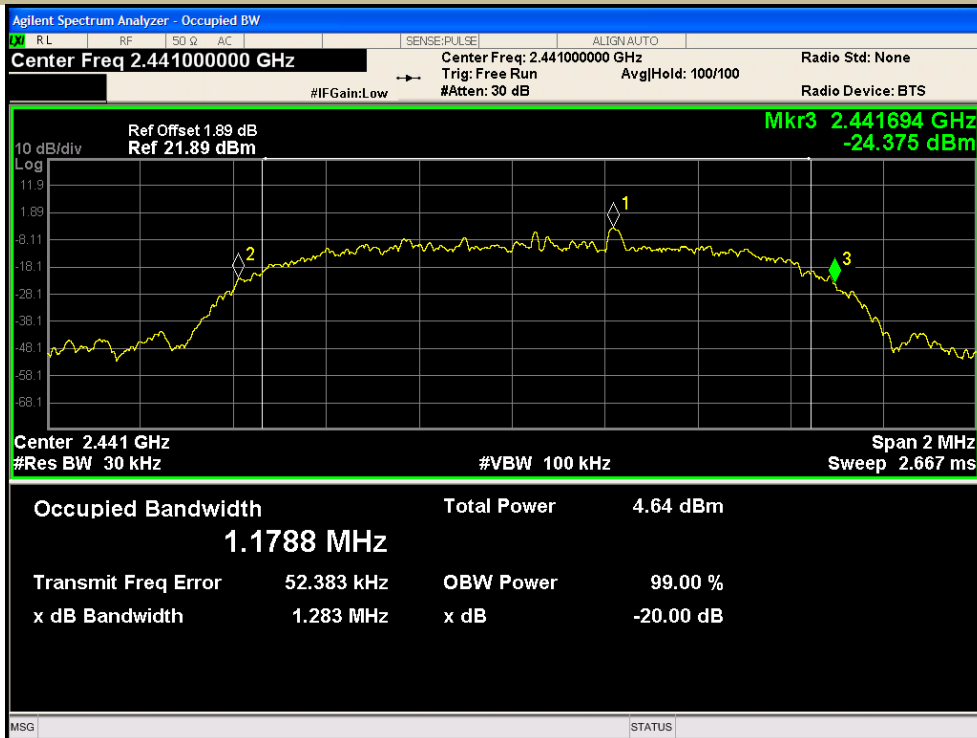

Test Model 20dB Bandwidth
Bluetooth V5.3
Channel 78: 2480MHz 8DPSK Modulation

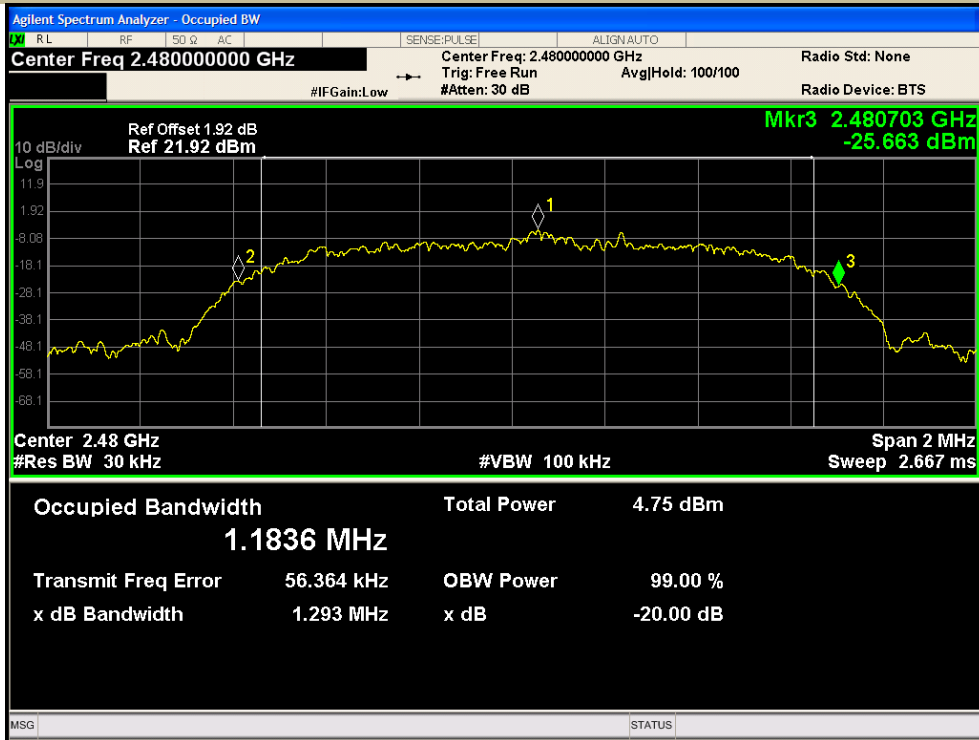

7.2 CARRIER FREQUENCY SEPARATION

7.2.1 Applicable Standard

According to FCC Part 15.247(a)(1) and KDB 558074 D01 15.247 MEAS GUIDANCE v05r02

7.2.2 Conformance Limit

Frequency hopping systems operating in the 2400-2483.5MHz band shall have hopping channel carrier frequencies separated by a minimum of 25kHz or the 20dB bandwidth of the hopping channel, whichever is greater.

In case of an output power less than 125mW, the frequency hopping system may have channels separated by a minimum of 25kHz or two-thirds of the 20dB bandwidth of the hopping channel, whichever is greater.

7.2.3 Test Configuration

Test according to clause 6.1 radio frequency test setup 1

7.2.4 Test Procedure

■ According to FCC Part 15.247(a)(1)

The EUT must have its hopping function enabled. Use the following spectrum analyzer settings:

Set the RBW = 30kHz. Set VBW = 100kHz.

Set the span = wide enough to capture the peaks of two adjacent channels

Set Sweep time = auto couple.

Set Detector = peak. Set Trace mode = max hold.

Allow the trace to stabilize. Use the marker-delta function to determine the separation between the peaks of the adjacent channels. The limit is specified in one of the subparagraphs of this Section. Submit this plot.

Test Results

Temperature:	26° C
Relative Humidity:	54%
ATM Pressure:	1011 mbar

Modulation Mode	Channel Number	Channel Frequency (MHz)	Measurement Bandwidth (kHz)	Limit (kHz)	Verdict
GFSK	0	2402	986	>665	PASS
	39	2441	992	>705	PASS
	78	2480	1008	>689	PASS
pi/4-DQPSK	0	2402	1198	>871	PASS
	39	2441	1069	>875	PASS
	78	2480	1028	>868	PASS
8DPSK	0	2402	1049	>871	PASS
	39	2441	924	>855	PASS
	78	2480	838	>862	PASS

Note: Limit = 20dB bandwidth * 2/3

Carrier Frequency Separation
Test Model Bluetooth V5.3
Channel 0: 2402MHz GFSK Modulation



Carrier Frequency Separation
Test Model Bluetooth V5.3
Channel 39: 2441MHz GFSK Modulation

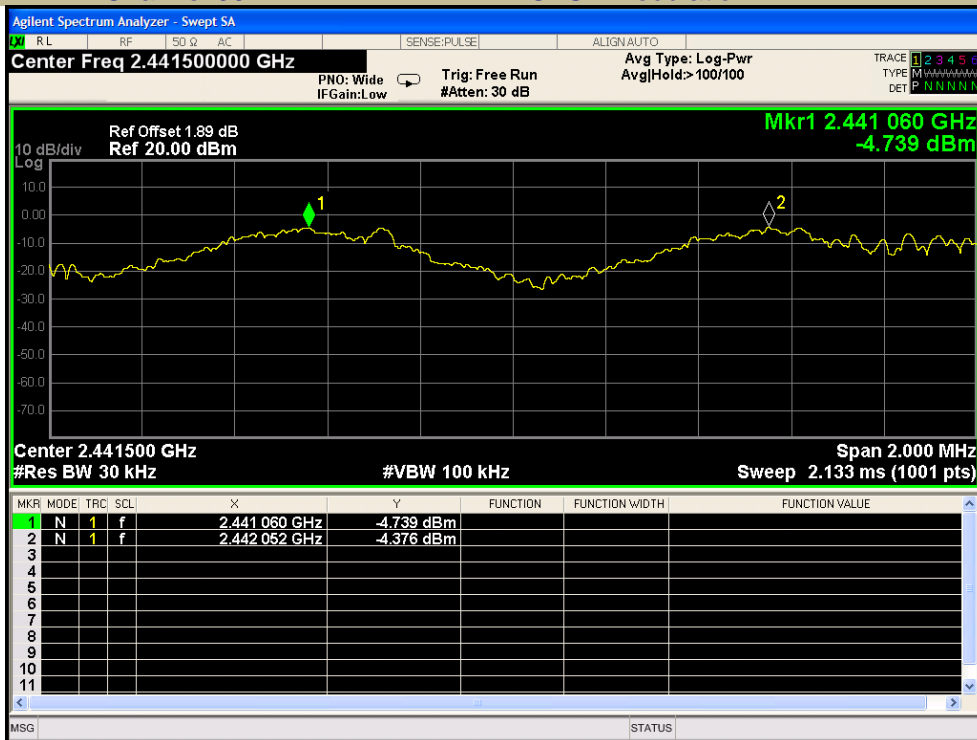

Test Model Carrier Frequency Separation
Bluetooth V5.3
Channel 78: 2480MHz GFSK Modulation

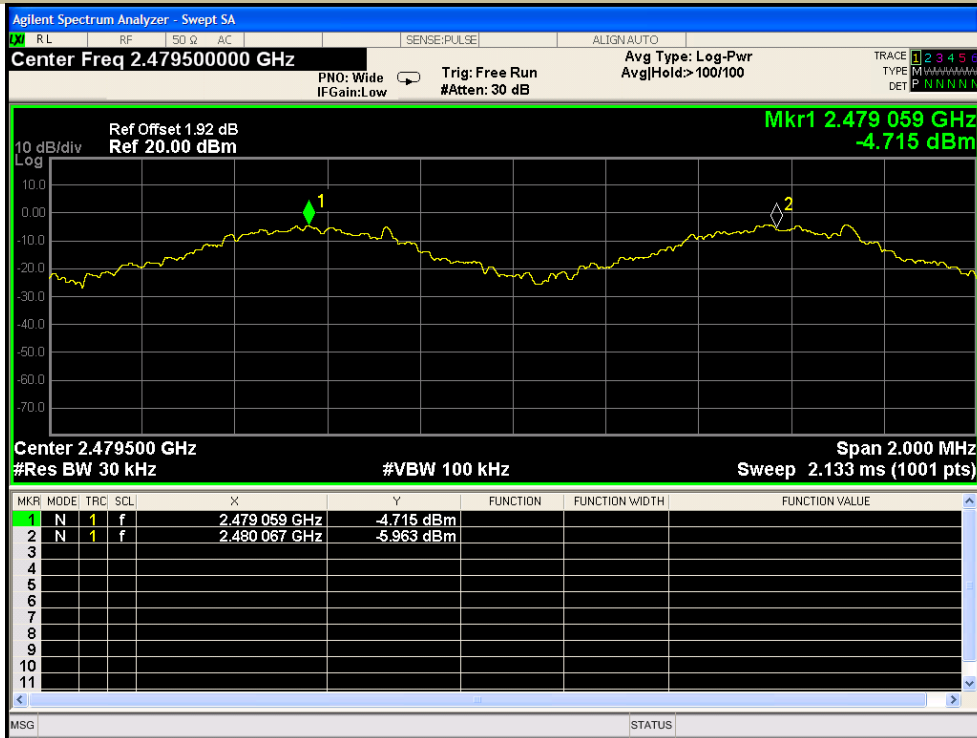

Test Model Carrier Frequency Separation
Bluetooth V5.3
Channel 0: 2402MHz pi/4-DQPSK Modulation

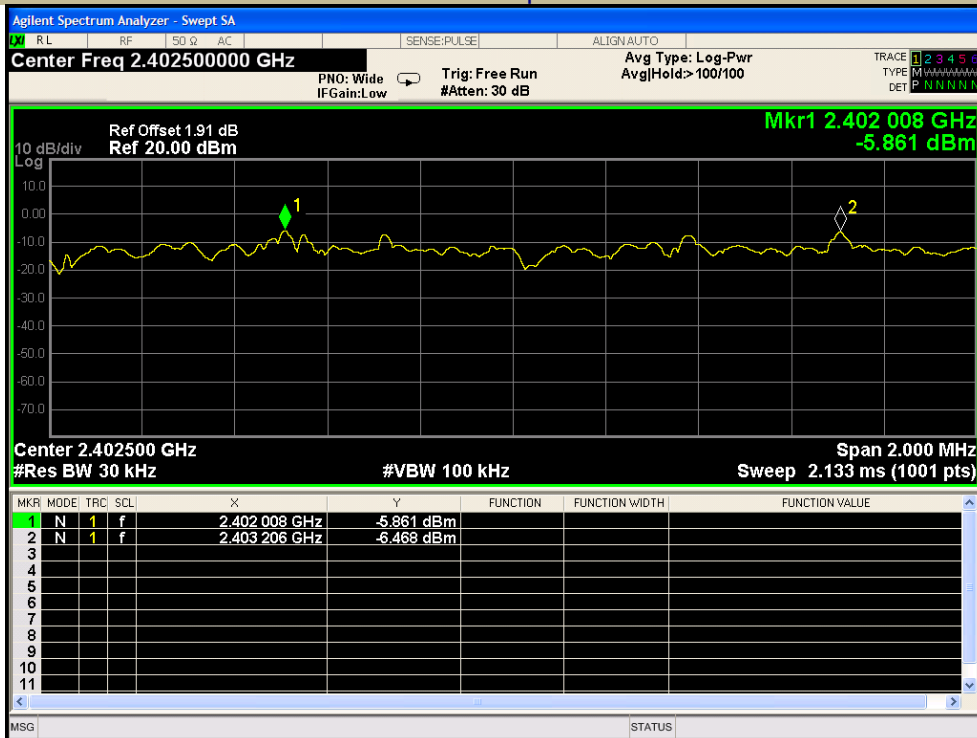

Carrier Frequency Separation
Test Model Bluetooth V5.3
Channel 39: 2441MHz pi/4-DQPSK Modulation

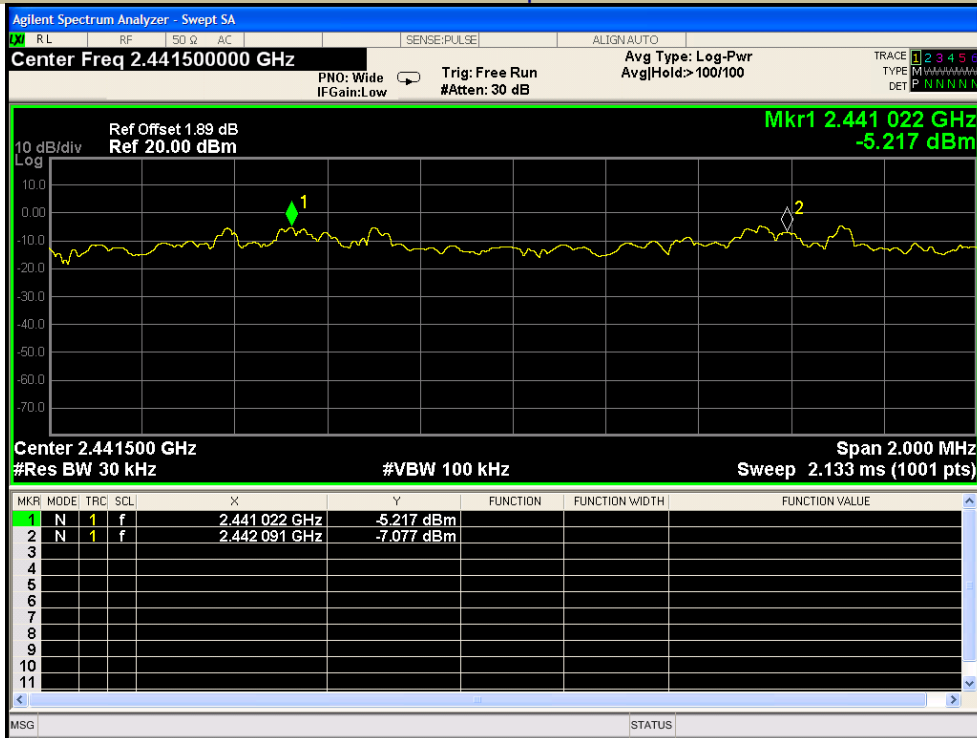

Carrier Frequency Separation
Test Model Bluetooth V5.3
Channel 78: 2480MHz pi/4-DQPSK Modulation

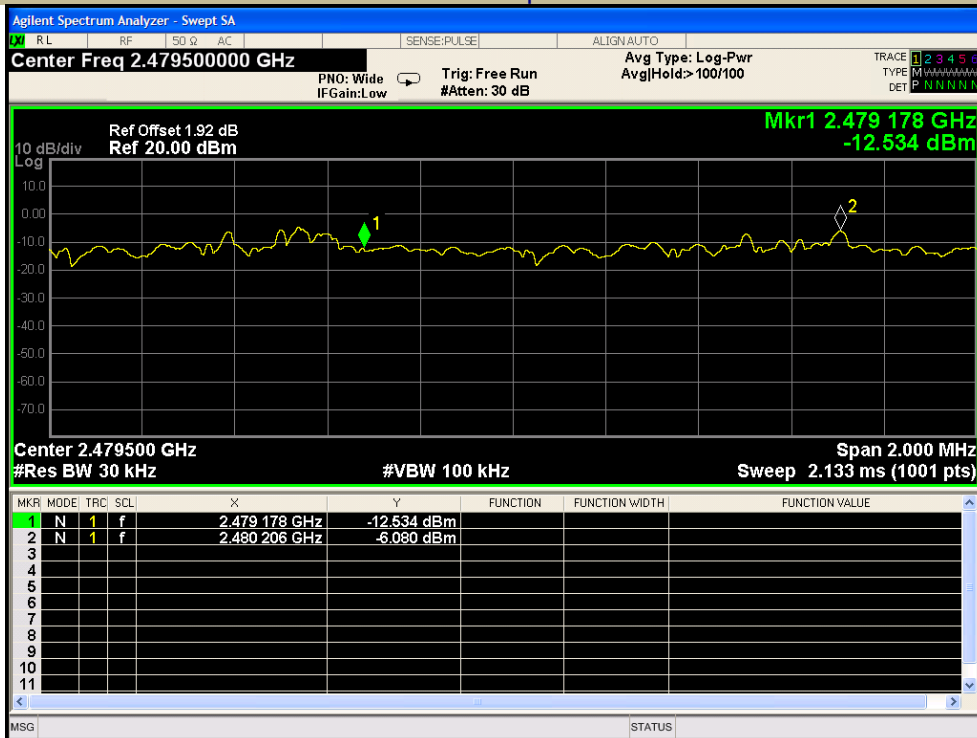

Carrier Frequency Separation
Test Model Bluetooth V5.3
Channel 0: 2402MHz 8DPSK Modulation

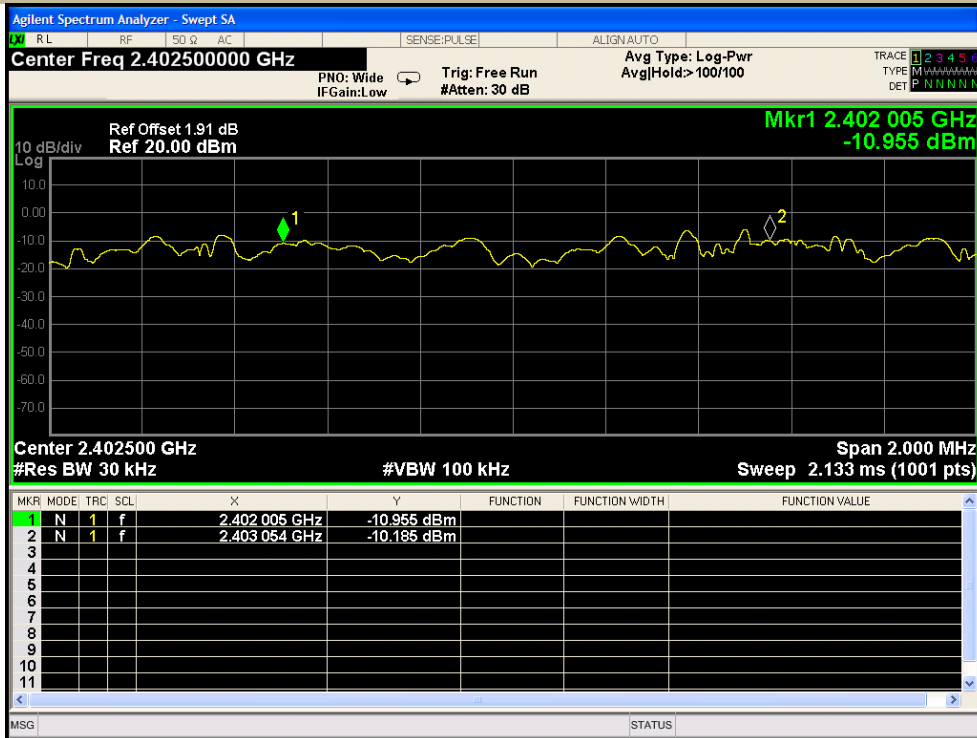

Carrier Frequency Separation
Test Model Bluetooth V5.3
Channel 39: 2441MHz 8DPSK Modulation

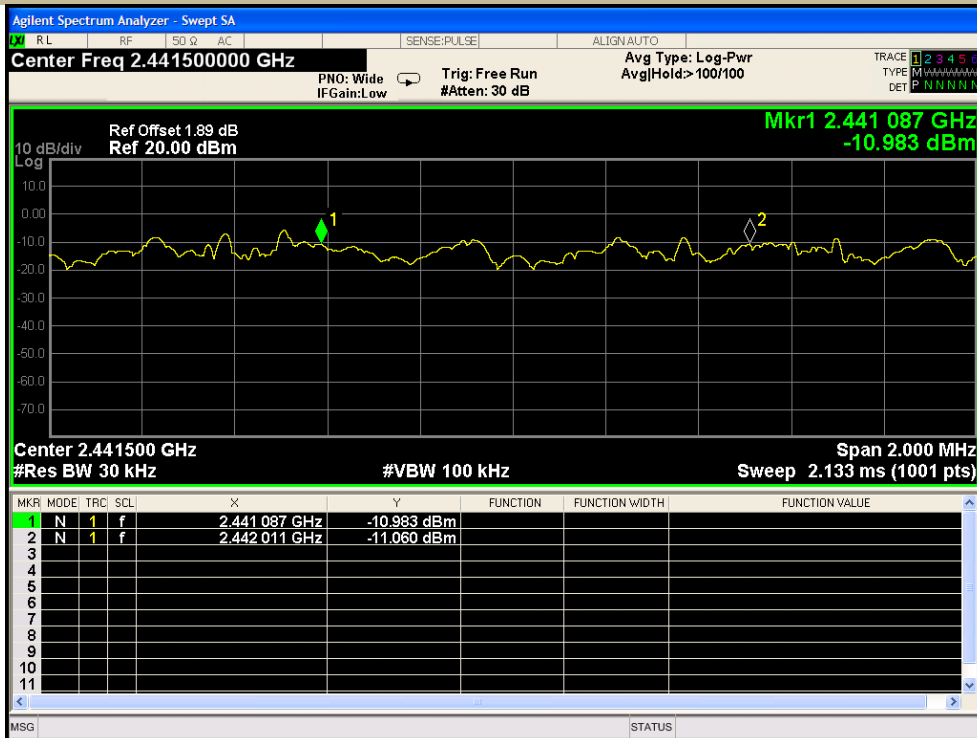

7.3 NUMBER OF HOPPING FREQUENCIES

7.3.1 Applicable Standard

According to FCC Part 15.247(a)(1) (iii) and KDB 558074 D01 15.247 MEAS GUIDANCE v05r02

7.3.2 Conformance Limit

Frequency hopping systems operating in the 2400-2483.5MHz band shall use at least 15 channels.

7.3.3 Test Configuration

Test according to clause 6.1 radio frequency test setup 1

7.3.4 Test Procedure

■ According to FCC Part 15.247(a)(1)(iii)

The EUT must have its hopping function enabled. Use the following spectrum analyzer settings:

Span = the frequency band of operation (2400-2483.5MHz)

RBW \geq 100KHz

VBW \geq RBW

Sweep = auto

Detector function = peak

Trace = max hold

Allow the trace to stabilize. It may prove necessary to break the span up to sections, in order to clearly show all of the hopping frequencies.

Test Results

Temperature:	26° C
Relative Humidity:	54%
ATM Pressure:	1011 mbar

Modulation Mode	Hopping Channel Frequency Range	Quantity of Hopping Channel	Quantity of Hopping Channel limit
GFSK	2402-2480	79	> 15
pi/4-DQPSK	2402-2480	79	> 15
8DPSK	2402-2480	79	> 15

Test Model Number Of Hopping Frequencies
Bluetooth V5.3
Span: 2400-2483.5MHz GFSK Modulation

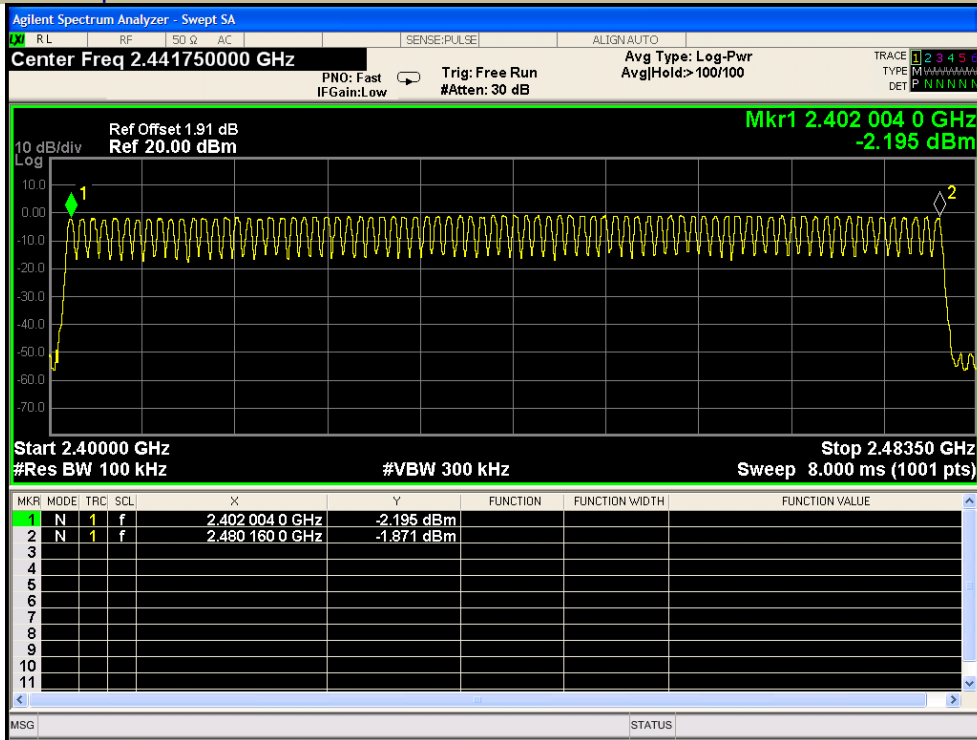

Test Model Number Of Hopping Frequencies
Bluetooth V5.3
Span: 2400-2483.5MHz pi/4-DQPSK Modulation

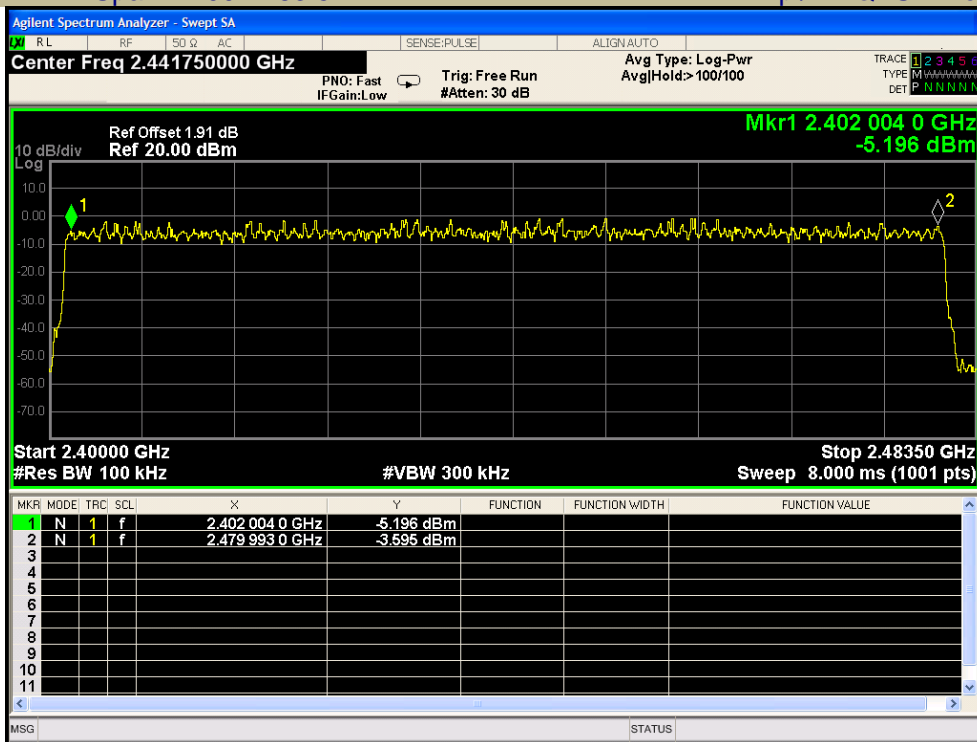

7.4 AVERAGE TIME OF OCCUPANCY (DWELL TIME)

7.4.1 Applicable Standard

According to FCC Part 15.247(a)(1)(iii) and KDB 558074 D01 15.247 MEAS GUIDANCE v05r02

7.4.2 Conformance Limit

For frequency hopping systems operating in the 2400-2483.5MHz band, the average time of occupancy on any channel shall not be greater than 0.4s within a period of 0.4s multiplied by the number of hopping channels employed.

7.4.3 Test Configuration

Test according to clause 6.1 radio frequency test setup 1

7.4.4 Test Procedure

■ According to FCC Part 15.247(a)(1)(iii)

The EUT must have its hopping function enabled. Use the following spectrum analyzer settings:

Span = zero span, centered on a hopping channel

RBW = 1 MHz

VBW \geq RBW

Sweep = as necessary to capture the entire dwell time per hopping channel

Detector function = peak

Trace = max hold

If possible, use the marker-delta function to determine the dwell time. If this value varies with different modes of operation (e.g., data rate, modulation format, etc.),

repeat this test for each variation. The limit is specified in one of the subparagraphs of this Section.

7.4.5 Test Results

Temperature:	26° C
Relative Humidity:	54%
ATM Pressure:	1011 mbar

Bluetooth (GFSK, pi/4-DQPSK, 8DPSK) mode have been tested, and the worst result(GFSK) was report as below:

Modulation Mode	Channel Number	Packet type	Pluse width (ms)	Dwell Time (ms)	Limit (ms)	Verdict
GFSK	0	DH1	0.383	122.560	<400	PASS
	0	DH3	1.639	262.240	<400	PASS
	0	DH5	1.834	195.627	<400	PASS

Note: Dwell Time(DH1)=PW*(1600/2/79)*31.6
 Dwell Time(DH3)=PW*(1600/4/79)*31.6
 Dwell Time(DH5)=PW*(1600/6/79)*31.6

Test Model Average Time Of Occupancy (Dwell Time)
 Bluetooth V5.3
 CH 0: 2402MHz GFSK DH1

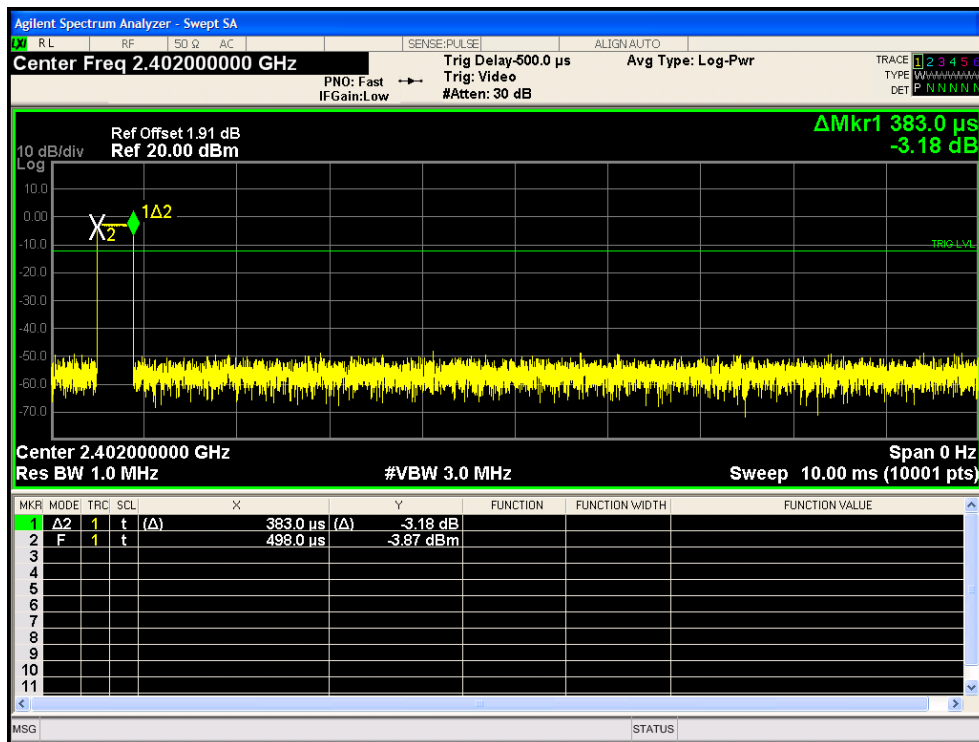

Test Model Average Time Of Occupancy (Dwell Time)
Bluetooth V5.3
CH 0: 2402MHz GFSK DH3

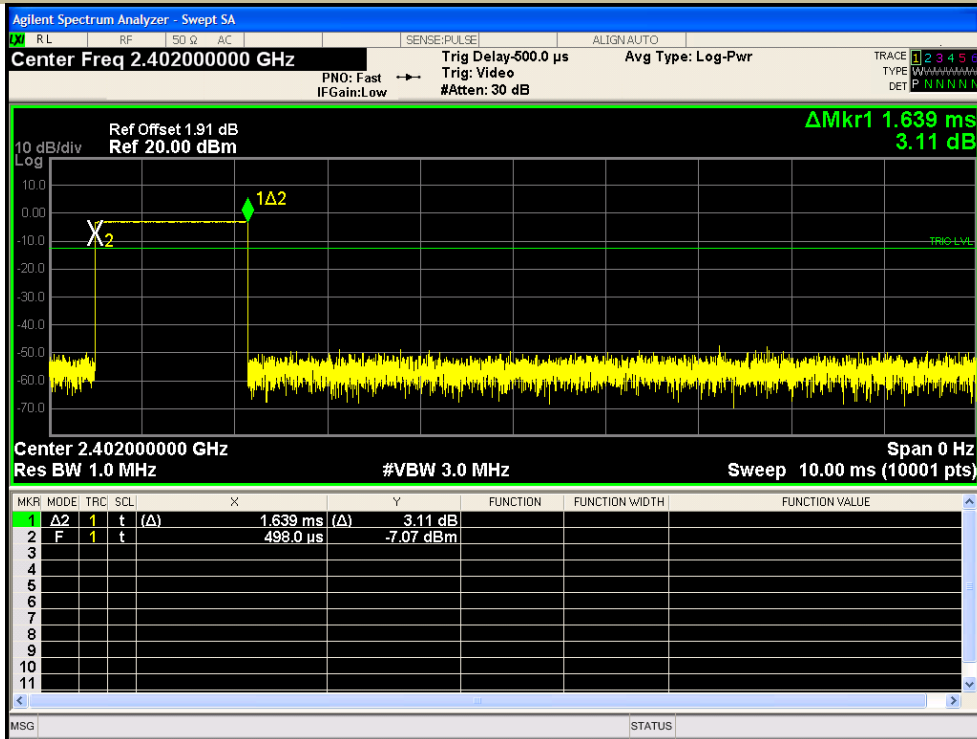

Test Model Average Time Of Occupancy (Dwell Time)
Bluetooth V5.3
CH 0: 2402MHz GFSK DH5

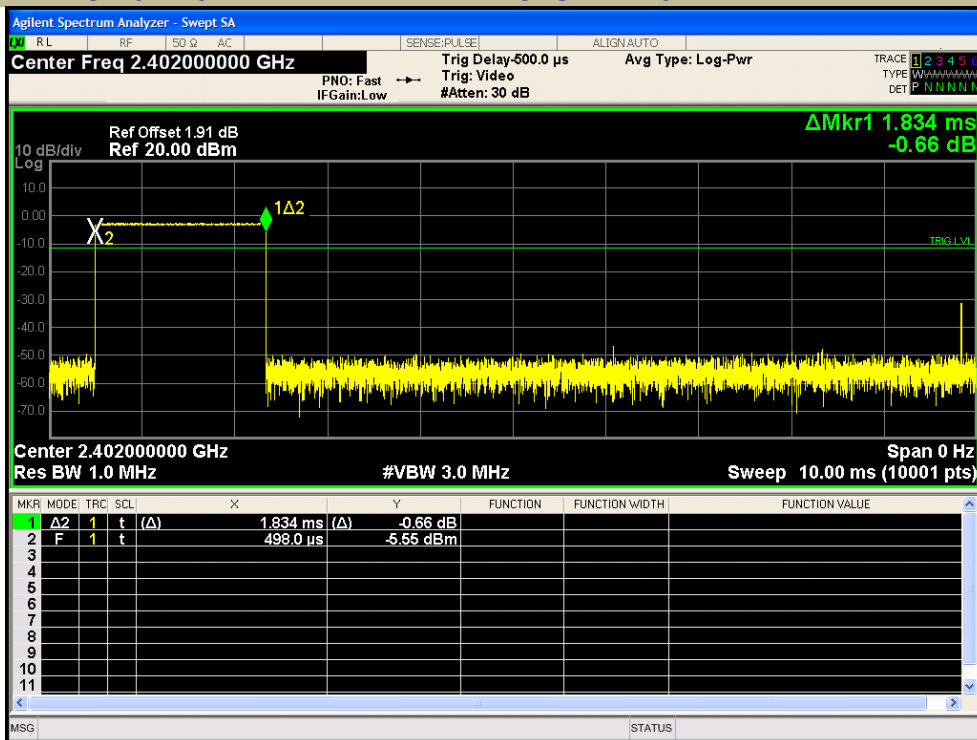

7.5 MAXIMUM PEAK CONDUCTED OUTPUT POWER

7.5.1 Applicable Standard

According to FCC Part 15.247(b)(1) and KDB 558074 D01 15.247 MEAS GUIDANCE v05r02

7.5.2 Conformance Limit

The max For frequency hopping systems operating in the 2400-2483.5 MHz band employing at least 75 non-overlapping hopping channels: 1 watt. For all other frequency hopping systems in the 2400-2483.5 MHz band: 0.125 watts.

7.5.3 Test Configuration

Test according to clause 6.1 radio frequency test setup 1

7.5.4 Test Procedure

■ According to FCC Part 15.247(b)(1)

As an alternative to a peak power measurement, compliance with the limit can be based on a measurement of the maximum conducted output power.

Use the following spectrum analyzer settings:

Set Span = approximately 5 times the 20 dB bandwidth, centered on a hopping channel

Set RBW > the 20 dB bandwidth of the emission being measured

Set VBW ≥ RBW

Set Sweep = auto

Set Detector function = peak

Set Trace = max hold

Allow the trace to stabilize. Use the marker-to-peak function to set the marker to the peak of the emission to determine the peak amplitude level.

Test Results

Temperature:	26° C
Relative Humidity:	54%
ATM Pressure:	1011 mbar

Operation Mode	Channel Number	Channel Frequency (MHz)	Measurement Level (dBm)	Limit (dBm)	Verdict
GFSK	0	2402	-2.44	21	PASS
	39	2441	-2.5	21	PASS
	78	2480	-2.28	21	PASS
pi/4-DQPSK	0	2402	-0.48	21	PASS
	39	2441	-0.41	21	PASS
	78	2480	-0.25	21	PASS
8DPSK	0	2402	0	21	PASS
	39	2441	-0.03	21	PASS
	78	2480	0.22	21	PASS
Note: N/A					

Test Model Maximum Peak Conducted Output Power
Bluetooth V5.3
Channel 0: 2402MHz GFSK

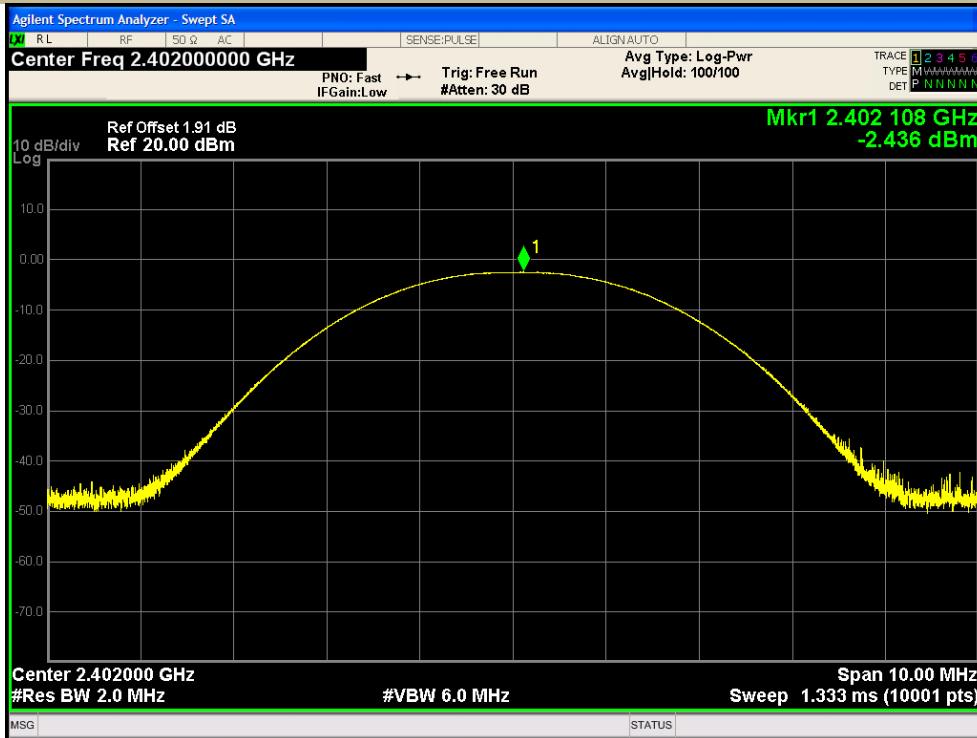

Test Model Maximum Peak Conducted Output Power
Bluetooth V5.3
Channel 39: 2441MHz GFSK

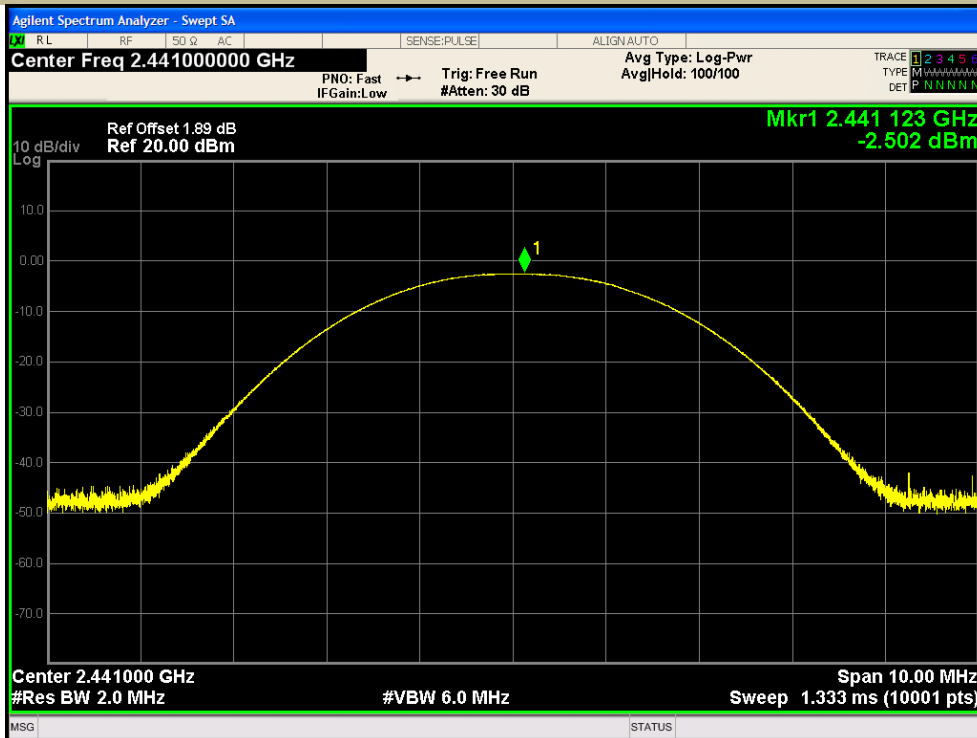

Test Model Maximum Peak Conducted Output Power
Bluetooth V5.3
Channel 78: 2480MHz GFSK

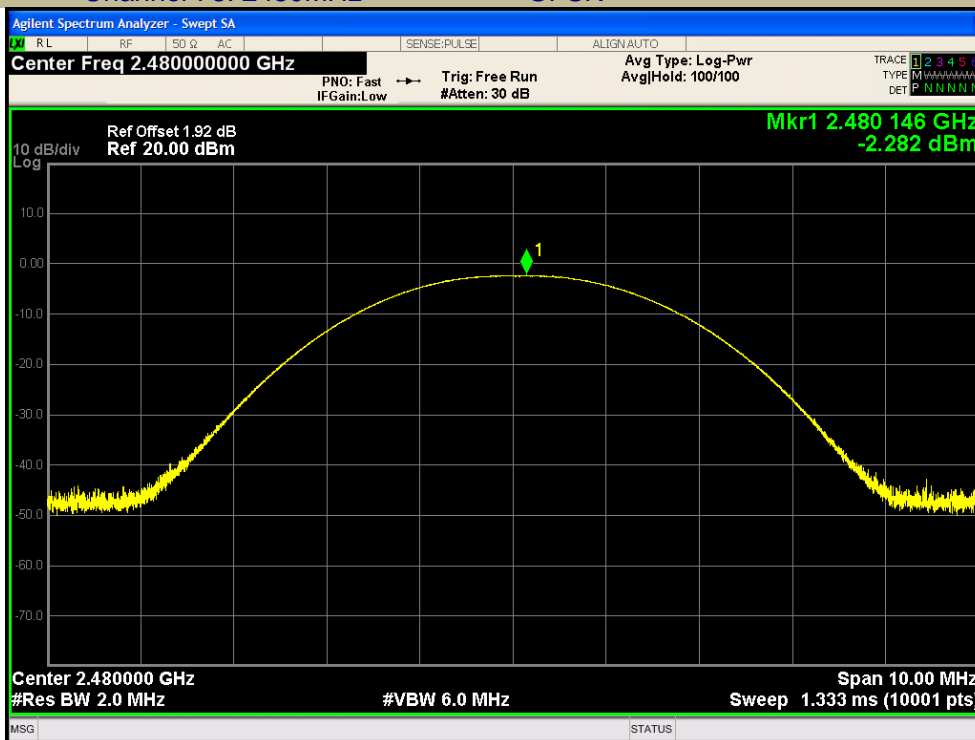

Test Model Maximum Peak Conducted Output Power
Bluetooth V5.3
Channel 0: 2402MHz pi/4-DQPSK

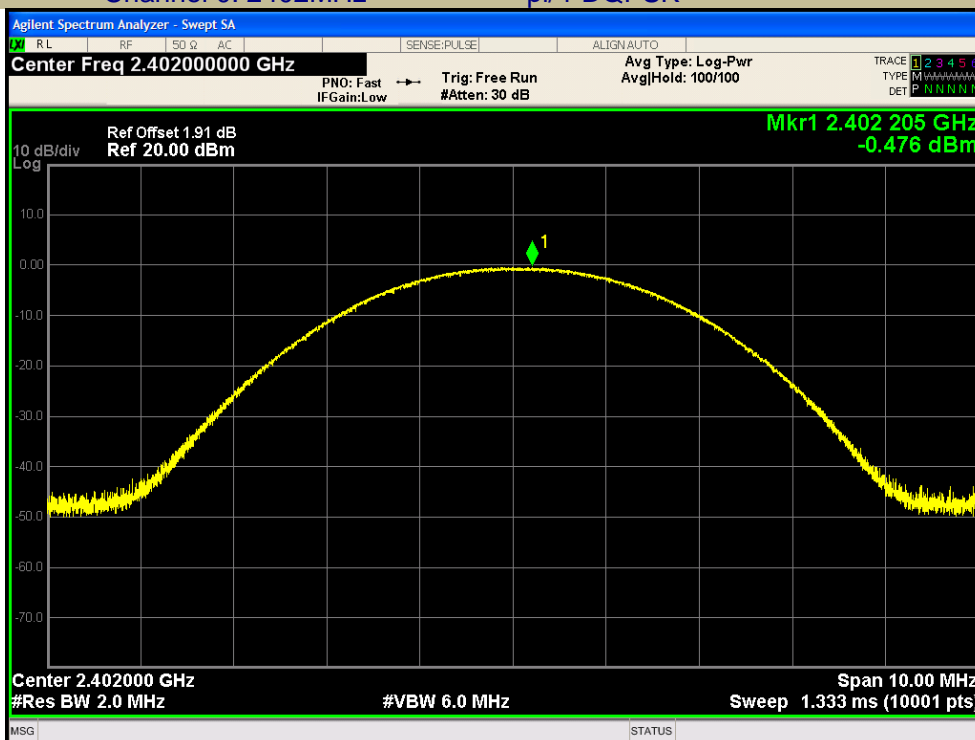

Test Model Maximum Peak Conducted Output Power
Bluetooth V5.3
Channel 39: 2441MHz pi/4-DQPSK

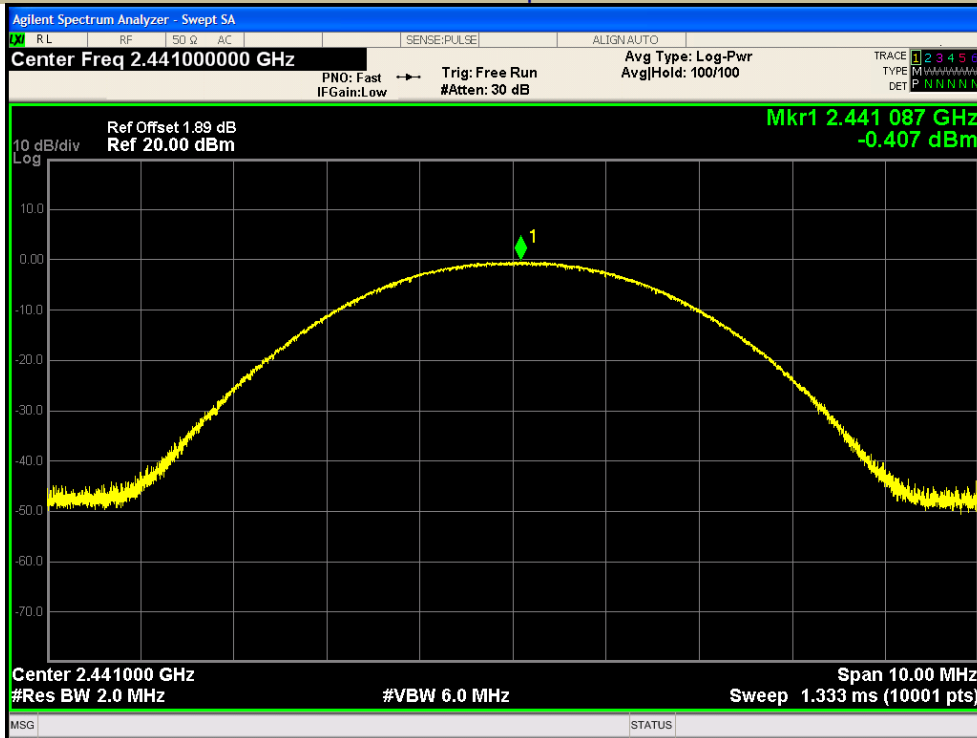

Test Model Maximum Peak Conducted Output Power
Bluetooth V5.3
Channel 78: 2480MHz pi/4-DQPSK

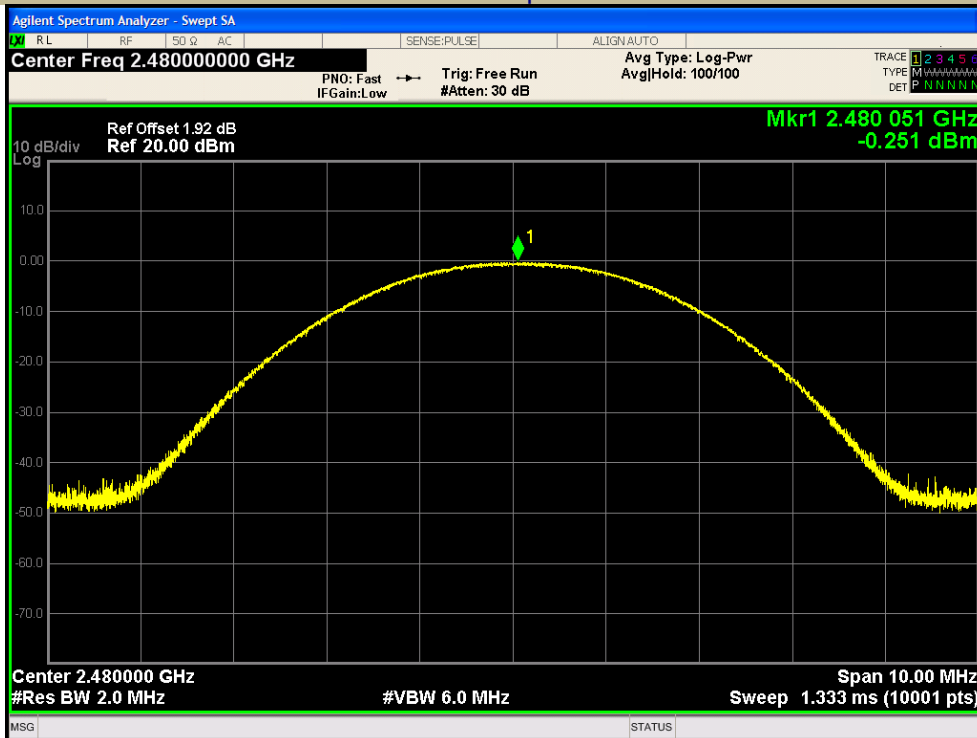

Test Model Maximum Peak Conducted Output Power
Bluetooth V5.3
Channel 0: 2402MHz 8DPSK

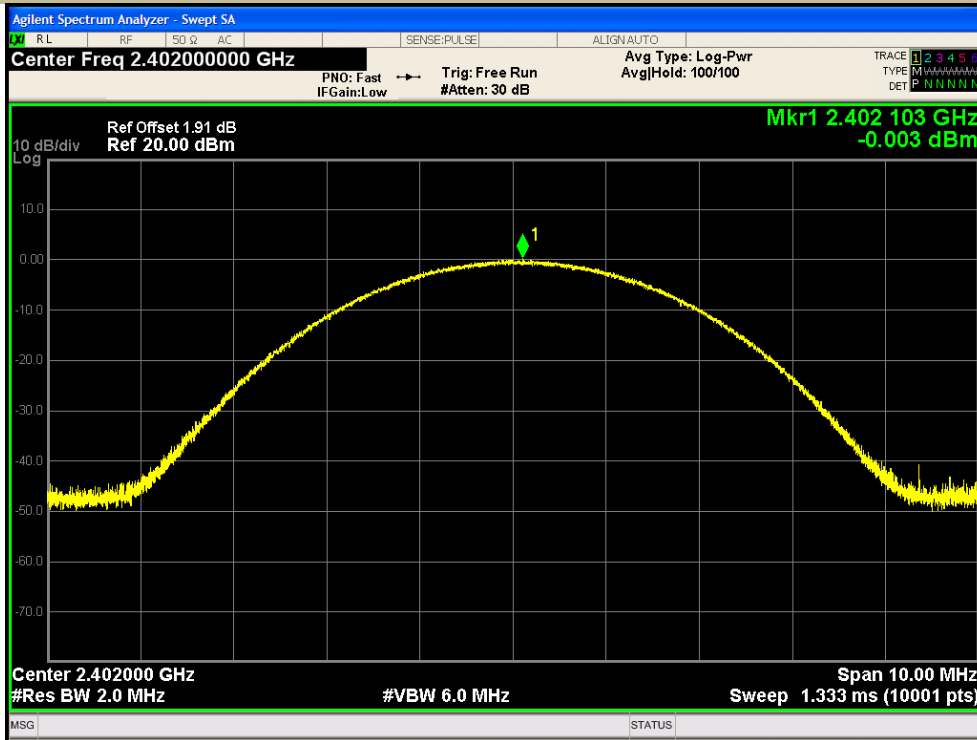

Test Model Maximum Peak Conducted Output Power
Bluetooth V5.3
Channel 39: 2441MHz 8DPSK

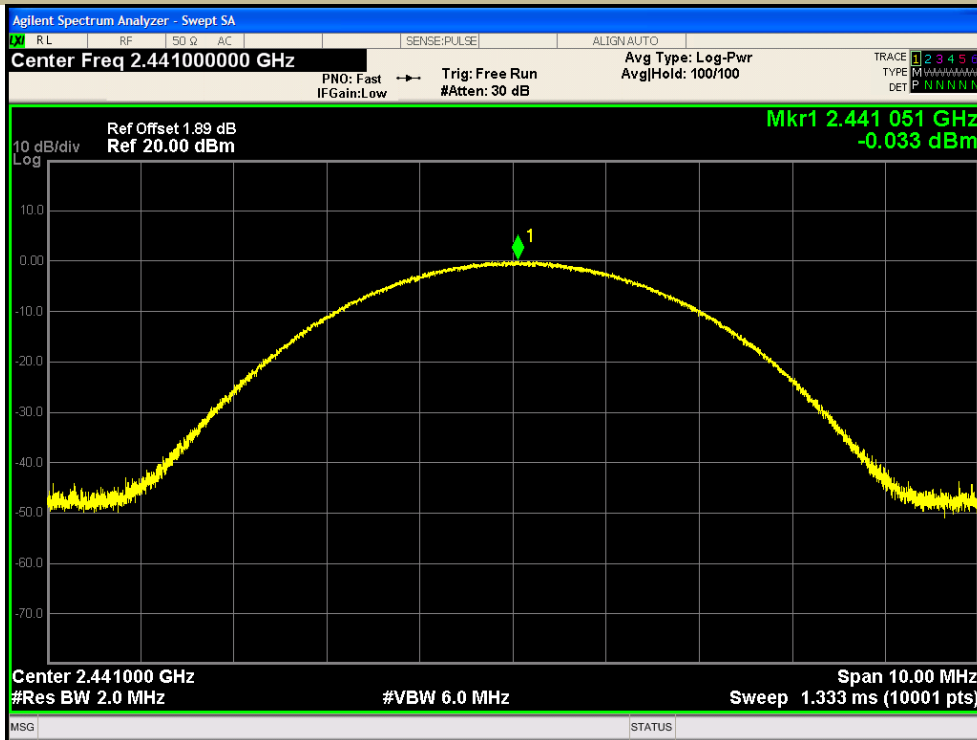

Test Model Maximum Peak Conducted Output Power
Bluetooth V5.3
Channel 78: 2480MHz 8DPSK

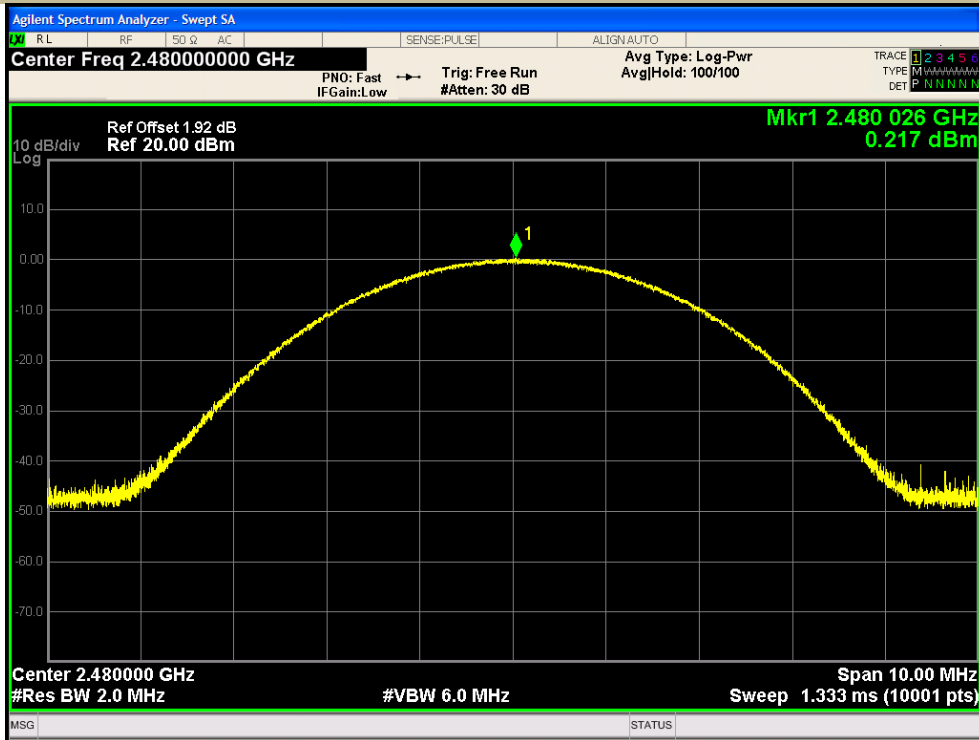

7.6 CONDUCTED SUPRIIOUS EMISSION

7.6.1 Applicable Standard

According to FCC Part 15.247(d) and KDB 558074 D01 15.247 MEAS GUIDANCE v05r02

7.6.2 Conformance Limit

According to FCC Part 15.247(d):

In any 100 kHz bandwidth outside the frequency band in which the spread spectrum intentional radiator is operating, the radio frequency power that is produced by the intentional radiator shall be at least 20 dB below that in the 100 kHz bandwidth within the band that contains the highest level of the desired power, based on either an RF conducted, provided the transmitter demonstrates compliance with the peak conducted power limits.

7.6.3 Test Configuration

Test according to clause 6.1 radio frequency test setup 1

7.6.4 Test Procedure

The transmitter output (antenna port) was connected to the spectrum analyzer

■ Reference level measurement

Establish a reference level by using the following procedure:

Set instrument center frequency to DSS channel center frequency.

Set Span = approximately 5 times the 20 dB bandwidth, centered on a hopping channel.

Set the RBW = 100 kHz. Set the VBW $\geq 3 \times$ RBW.

Set Detector = peak. Set Sweep time = auto couple.

Set Trace mode = max hold. Allow trace to fully stabilize.

Use the peak marker function to determine the maximum Maximum conduceted level.

Note that the channel found to contain the maximum conduceted level can be used to establish the reference level.

■ Band-edge Compliance of RF Conducted Emissions

Use the following spectrum analyzer settings:

Span = wide enough to capture the peak level of the emission operating on the channel closest to the band-edge, as well as any modulation products which fall outside of the authorized band of operation

Set RBW $\geq 1\%$ of the span=100kHz Set VBW \geq RBW

Set Sweep = auto Set Detector function = peak Set Trace = max hold

Allow the trace to stabilize. Set the marker on the emission at the bandedge, or on the highest modulation product outside of the band, if this level is greater than that at the bandedge. Enable the marker-delta function, then use the marker-to-peak function to move the marker to the peak of the in-band emission. The marker-delta value now displayed must comply with the limit specified in this Section.

Now, using the same instrument settings, enable the hopping function of the EUT. Allow the trace to stabilize. Follow the same procedure listed above to determine if any spurious emissions caused by the hopping function also comply with the specified limit.

■ Conduceted Spurious RF Conducted Emission

Use the following spectrum analyzer settings:

Span = wide enough to capture the peak level of the in-band emission and all spurious emissions (e.g., harmonics) from the lowest frequency generated in the EUT up through the 10th

harmonic.(30MHz to 25GHz). Set RBW = 100 kHz Set VBW \geq RBW

Set Sweep = auto Set Detector function = peak Set Trace = max hold

Allow the trace to stabilize. Set the marker on the peak of any spurious emission recorded. The level displayed must comply with the limit specified in this Section.

Test Model Band-edge Conducted Emissions
Bluetooth V5.3
Channel 0: 2402MHz GFSK

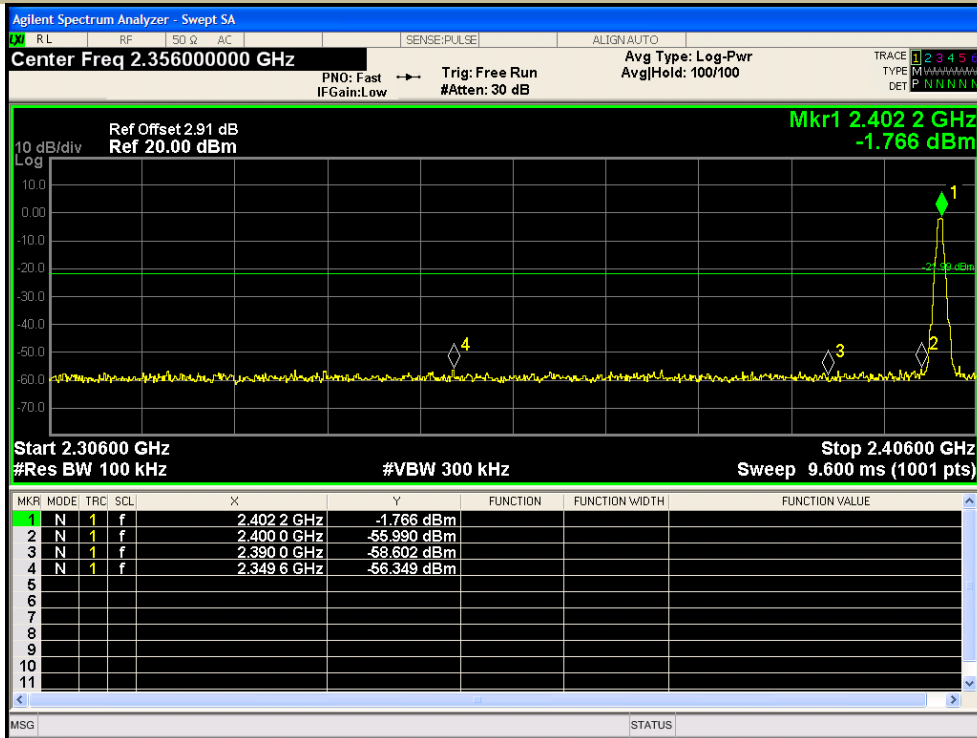

Test Model Maximum Conducted Level RBW=100kHz
Bluetooth V5.3
Channel 39: 2441MHz GFSK

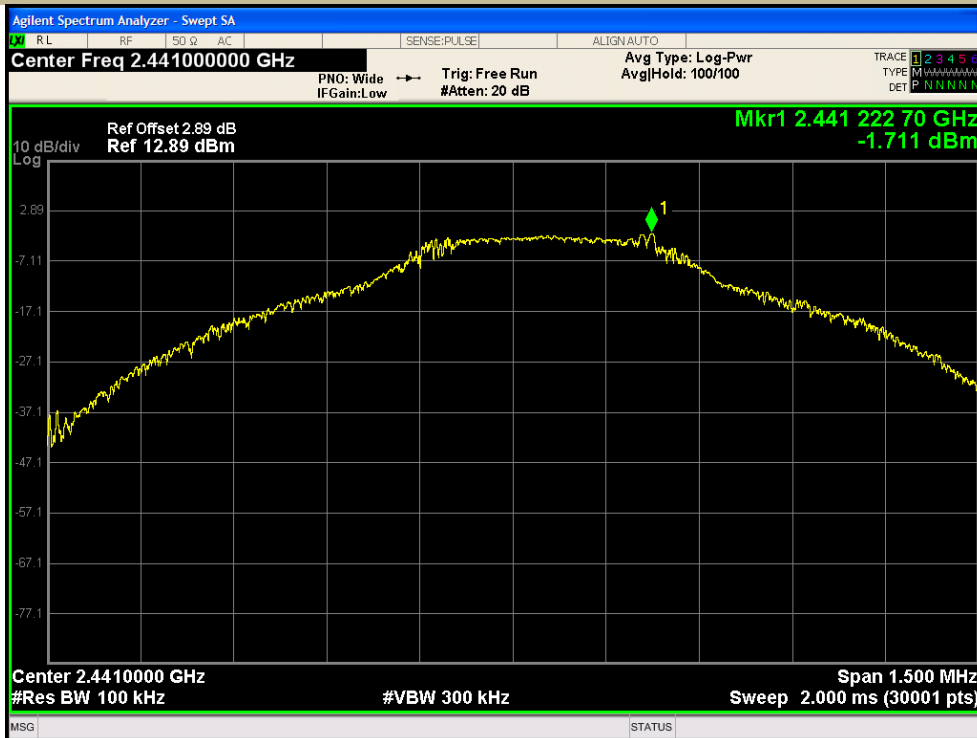

Test Model **Conducted Spurious RF Conducted Emission**
Bluetooth V5.3
Channel 39: 2441MHz **GFSK**

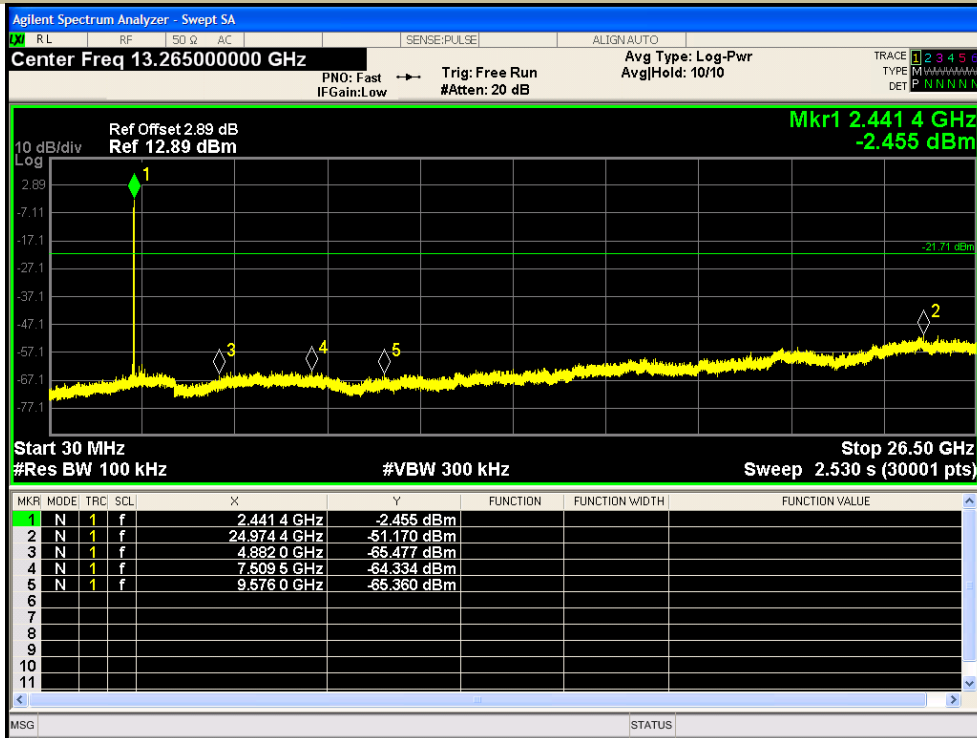

Test Model **Maximum Conducted Level RBW=100kHz**
Bluetooth V5.3
Channel 78: 2480MHz **GFSK**

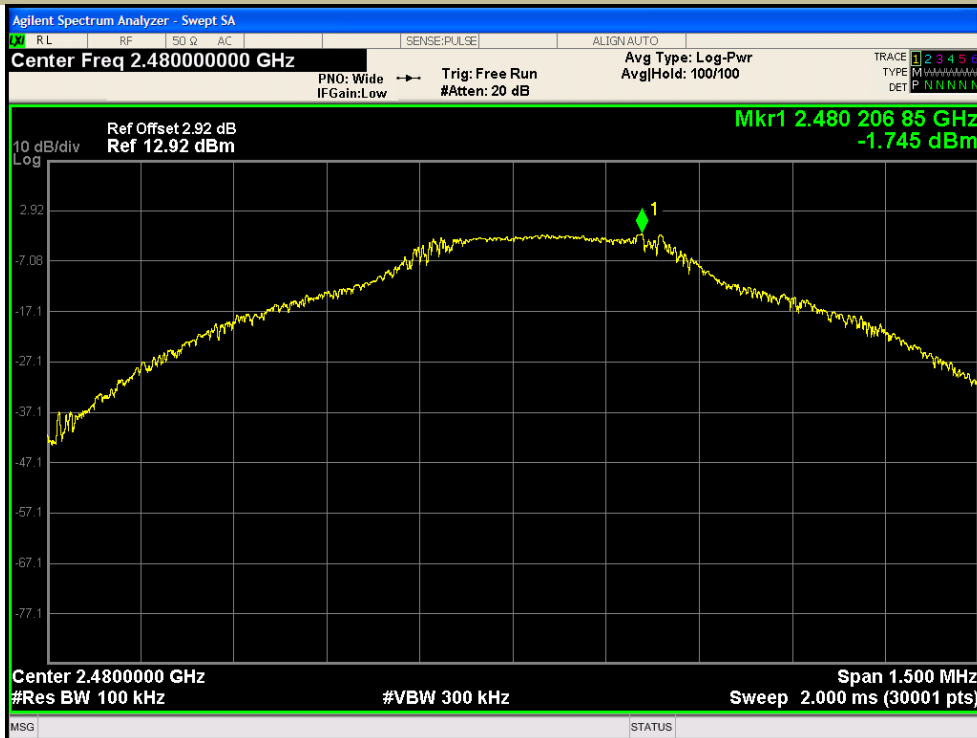

Test Model **Conducted Spurious RF Conducted Emission**
Bluetooth V5.3
Channel 78: 2480MHz **GFSK**

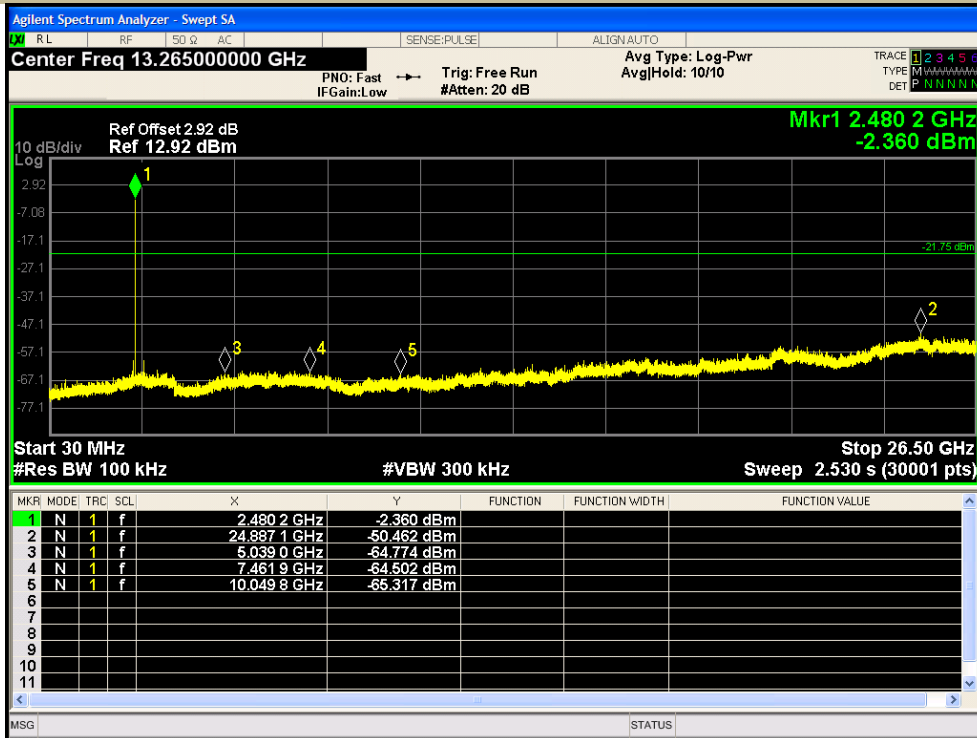

Test Model **Band-edge Conducted Emissions**
Bluetooth V5.3
Channel 78: 2480MHz **GFSK**

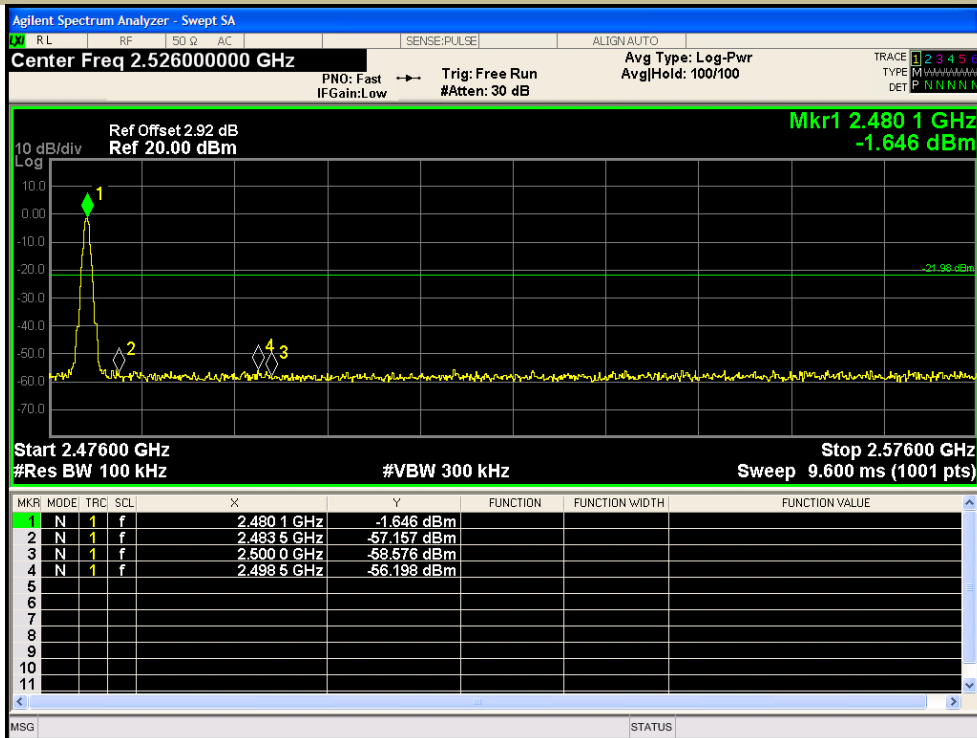

Test Model Maximum Conduced Level RBW=100kHz
Bluetooth V5.3
Hopping GFSK



Test Model Conduced Spurious RF Conducted Emission
Bluetooth V5.3
Hopping GFSK

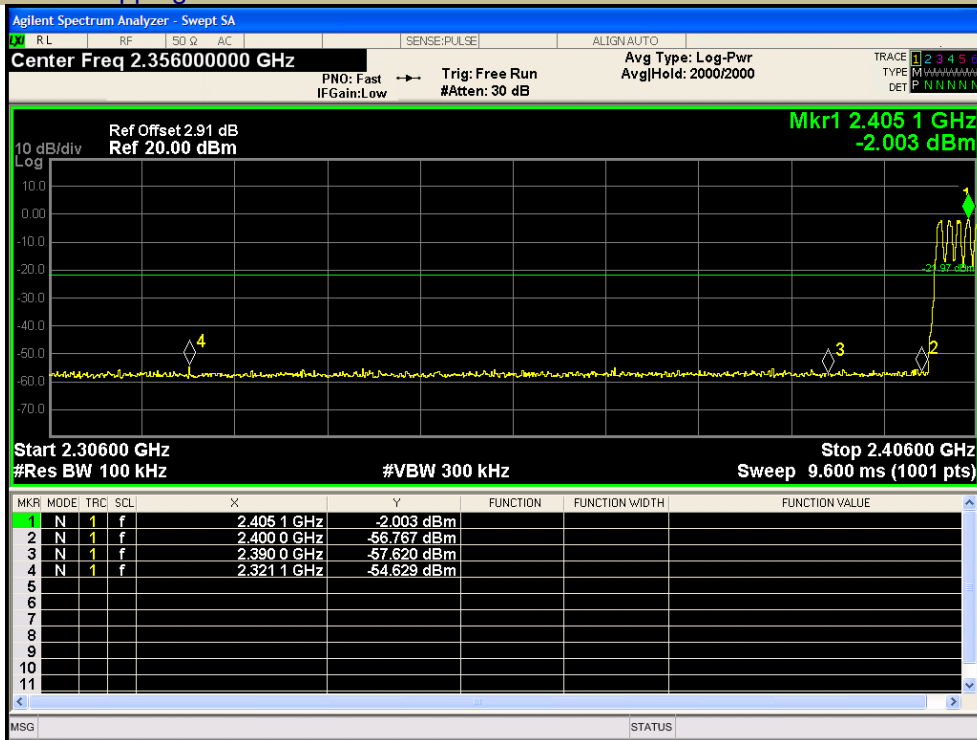

Test Model **Band-edge Conducted Emissions**
Bluetooth V5.3
Hopping **GFSK**



Test Model **Band-edge Conducted Emissions**
Bluetooth V5.3
Hopping **GFSK**

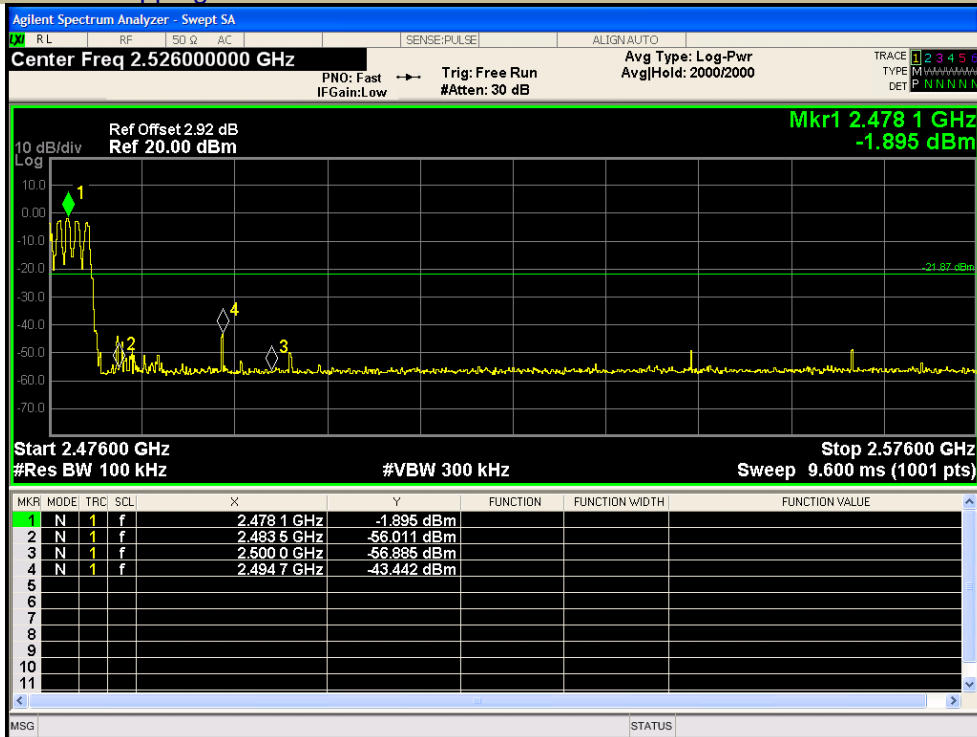

7.7 RADIATED SPURIOUS EMISSION

7.7.1 Applicable Standard

According to FCC Part 15.247(d) and 15.209 and KDB 558074 D01 15.247 MEAS GUIDANCE v05r02

7.7.2 Conformance Limit

According to FCC Part 15.247(d): radiated emissions which fall in the restricted bands, as defined in §15.205(a), must also comply with the radiated emission limits specified in §15.209(a) (see §15.205(c)).

According to FCC Part 15.205, Restricted bands

MHz	MHz	MHz	GHz
0.090-0.110	16.42-16.423	399.9-410	4.5-5.15
10.495-0.505	16.69475-16.69525	608-614	5.35-5.46
2.1735-2.1905	16.80425-16.80475	960-1240	7.25-7.75
4.125-4.128	25.5-25.67	1300-1427	8.025-8.5
4.17725-4.17775	37.5-38.25	1435-1626.5	9.0-9.2
4.20725-4.20775	73-74.6	1645.5-1646.5	9.3-9.5
6.215-6.218	74.8-75.2	1660-1710	10.6-12.7
6.26775-6.26825	123-138	2200-2300	14.47-14.5
8.291-8.294	149.9-150.05	2310-2390	15.35-16.2
8.362-8.366	156.52475-156.52525	2483.5-2500	17.7-21.4
8.37625-8.38675	156.7-156.9	2690-2900	22.01-23.12
8.41425-8.41475	162.0125-167.17	3260-3267	23.6-24.0
12.29-12.293	167.72-173.2	3332-3339	31.2-31.8
12.51975-12.52025	240-285	3345.8-3358	36.43-36.5
12.57675-12.57725	322-335.4	3600-4400	(2)
13.36-13.41			

According to FCC Part 15.205, the level of any transmitter spurious emission in Restricted bands shall not exceed the level of the emission specified in the following table

Restricted Frequency(MHz)	Field Strength ($\mu\text{V}/\text{m}$)	Field Strength ($\text{dB}\mu\text{V}/\text{m}$)	Measurement Distance
0.009-0.490	2400/F(KHz)	20 log ($\mu\text{V}/\text{m}$)	300
0.490-1.705	24000/F(KHz)	20 log ($\mu\text{V}/\text{m}$)	30
1.705-30	30	29.5	30
30-88	100	40	3
88-216	150	43.5	3
216-960	200	46	3
Above 960	500	54	3

7.7.3 Test Configuration

Test according to clause 6.2 radio frequency test setup 2

7.7.4 Test Procedure

This test is required for any spurious emission that falls in a Restricted Band, as defined in Section 15.205. It must be performed with the highest gain of each type of antenna proposed for use with the EUT. Use the following spectrum analyzer settings:

For Above 1GHz:

The EUT was placed on a turn table which is 1.5m above ground plane.

Maximum procedure was performed on the highest emissions to ensure EUT compliance.

Span = wide enough to fully capture the emission being measured

RBW = 1 MHz

VBW \geq RBW

Sweep = auto

Detector function = peak

Trace = max hold

For Below 1GHz:

The EUT was placed on a turn table which is 0.8m above ground plane.

Maximum procedure was performed on the highest emissions to ensure EUT compliance.

Span = wide enough to fully capture the emission being measured

RBW = 100 kHz

VBW \geq RBW

Sweep = auto

Detector function = peak

Trace = max hold

For Below 30MHz:

The EUT was placed on a turn table which is 0.8m above ground plane.

Maximum procedure was performed on the highest emissions to ensure EUT compliance.

Span = wide enough to fully capture the emission being measured

RBW = 9kHz

VBW \geq RBW

Sweep = auto

Detector function = peak

Trace = max hold

For Below 150KHz:

The EUT was placed on a turn table which is 0.8m above ground plane.

Maximum procedure was performed on the highest emissions to ensure EUT compliance.

Span = wide enough to fully capture the emission being measured

RBW = 200Hz

VBW \geq RBW

Sweep = auto

Detector function = peak

Trace = max hold

Follow the guidelines in ANSI C63.10-2013 with respect to maximizing the emission by rotating the EUT, measuring the emission while the EUT is situated in three orthogonal planes (if appropriate), adjusting the measurement antenna height and polarization, etc. A pre-amp and a high pass filter are required for this test, in order to provide the measuring system with sufficient sensitivity. Allow the trace to stabilize. The peak reading of the emission, after being corrected by the antenna factor, cable loss, pre-amp gain, etc., is the peak field strength, which must comply with the limit specified in Section 15.35(b). Submit this data.

Now set the VBW to 10 Hz, while maintaining all of the other instrument settings. This peak level, once corrected, must comply with the limit specified in Section 15.209. If the dwell time per channel of the hopping signal is less than 100 ms, then the reading obtained with the 10 Hz VBW may be further adjusted by a "duty cycle correction factor", derived from $20\log(\text{dwell time}/100 \text{ ms})$, in an effort to demonstrate compliance with the 15.209 limit. Submit this data.

Repeat above procedures until all frequency measured was complete.

7.7.5 Test Results

■ Spurious Emission below 30MHz (9KHz to 30MHz)

Temperature:	26° C
Relative Humidity:	54%
ATM Pressure:	1011 mbar

Freq. (MHz)	Ant.Pol. H/V	Emission Level(dBuV/m)		Limit 3m(dBuV/m)		Over(dB)	
		PK	AV	PK	AV	PK	AV
--	--	--	--	--	--	--	--

Note: the amplitude of spurious emission that is attenuated by more than 20dB below the permissible limit has no need to be reported.

Distance extrapolation factor = $40 \log(\text{Specific distance} / \text{test distance})$ (dB);

Limit line = Specific limits(dBuV) + distance extrapolation factor

■ Spurious Emission Above 1GHz (1GHz to 25GHz)
 Bluetooth (GFSK, pi/4-DQPSK, 8DPSK) mode have been tested, and the worst result(GFSK) was report as below:

Test mode: GFSK Frequency: Channel 0: 2402MHz

Freq. (MHz)	Ant. Pol. H/V	Emission Level(dBuV/m)		Limit 3m(dBuV/m)		Over(dB)	
		PK	AV	PK	AV	PK	AV
4765.03	V	55.89	42.78	74	54	-18.11	-11.22
7181.88	V	57.73	41.19	74	54	-16.27	-12.81
7225.38	V	58.49	43.56	74	54	-15.51	-10.44
4766.63	H	45.53	44.03	74	54	-28.47	-9.97
7156.05	H	58.94	43.68	74	54	-15.06	-10.32
14412.71	H	58.49	44.46	74	54	-15.51	-9.54

Test mode: GFSK Frequency: Channel 39: 2441MHz

Freq. (MHz)	Ant. Pol. H/V	Emission Level(dBuV/m)		Limit 3m(dBuV/m)		Over(dB)	
		PK	AV	PK	AV	PK	AV
4751.75	V	52.61	42.32	74	54	-21.39	-11.68
7222.74	V	46.27	35.30	74	54	-27.73	-18.70
12283.62	V	51.07	39.89	74	54	-22.93	-14.11
4843.06	H	46.56	42.03	74	54	-27.44	-11.97
71591.74	H	48.77	43.49	74	54	-25.23	-10.51
14925.83	H	55.50	41.81	74	54	-18.50	-12.19

Test mode: GFSK Frequency: Channel 78: 2480MHz

Freq. (MHz)	Ant. Pol. H/V	Emission Level(dBuV/m)		Limit 3m(dBuV/m)		Over(dB)	
		PK	AV	PK	AV	PK	AV
4824.87	V	48.63	36.74	74	54	-25.37	-17.26
7244.14	V	47.86	35.65	74	54	-26.14	-18.35
12341.94	V	58.97	39.95	74	54	-15.03	-14.05
4822.17	H	48.52	41.62	74	54	-25.48	-12.38
7222.01	H	47.80	42.20	74	54	-26.20	-11.80
14292.68	H	47.36	38.97	74	54	-26.64	-15.03

- Note:**
- (1) All Readings are Peak Value (VBW=3MHz) and Peak Value (VBW=10Hz).
 - (2) Emission Level= Reading Level+Probe Factor +Cable Loss.
 - (3) Data of measurement within this frequency range shown "--" in the table above means the reading of emissions are attenuated more than 20dB below the permissible limits or the field strength is too small to be measured.

■ Spurious Emission in Restricted Band 2310-2390MHz and 2483.5-2500MHz Bluetooth (GFSK, pi/4-DQPSK, 8DPSK, Hopping) mode have been tested, and the worst result(GFSK, Hopping) was report as below:

Test mode: GFSK Frequency: Channel 0: 2402MHz

Frequency (MHz)	Polarity H/V	PK(dBuV/m) (VBW=3MHz)	Limit 3m (dBuV/m)	AV(dBuV/m) (VBW=10Hz)	Limit 3m (dBuV/m)
2341.20	H	43.92	74.00	34.62	54.00
2338.63	V	45.52	74.00	36.85	54.00

Test mode: GFSK Frequency: Channel 78: 2480MHz

Frequency (MHz)	Polarity H/V	PK(dBuV/m) (VBW=3MHz)	Limit 3m (dBuV/m)	AV(dBuV/m) (VBW=10Hz)	Limit 3m (dBuV/m)
2496.63	H	47.97	74.00	38.60	54.00
2493.49	V	47.75	74.00	38.37	54.00

Test mode: GFSK Frequency: Hopping

Frequency (MHz)	Polarity H/V	PK(dBuV/m) (VBW=3MHz)	Limit 3m (dBuV/m)	AV(dBuV/m) (VBW=10Hz)	Limit 3m (dBuV/m)
2400.00	H	53.39	74.00	41.60	54.00
2483.50	H	47.14	74.00	38.95	54.00
2400.00	V	51.34	74.00	41.35	54.00
2483.50	V	48.30	74.00	39.32	54.00

Note: (1) All Readings are Peak Value (VBW=3MHz) and Peak Value (VBW=10Hz).
 (2) Emission Level= Reading Level+Probe Factor +Cable Loss.

Test Model	Spurious Emission in Restricted Band 2310-2390MHz		
	Bluetooth V5.3 Channel 0: 2402MHz		
		GFSK	H
		Test By: Ken Zhao	

Model No.:	Y113S	Test Power :	DC 3.7V
Temperature:	26 °C	Humidity:	55 %

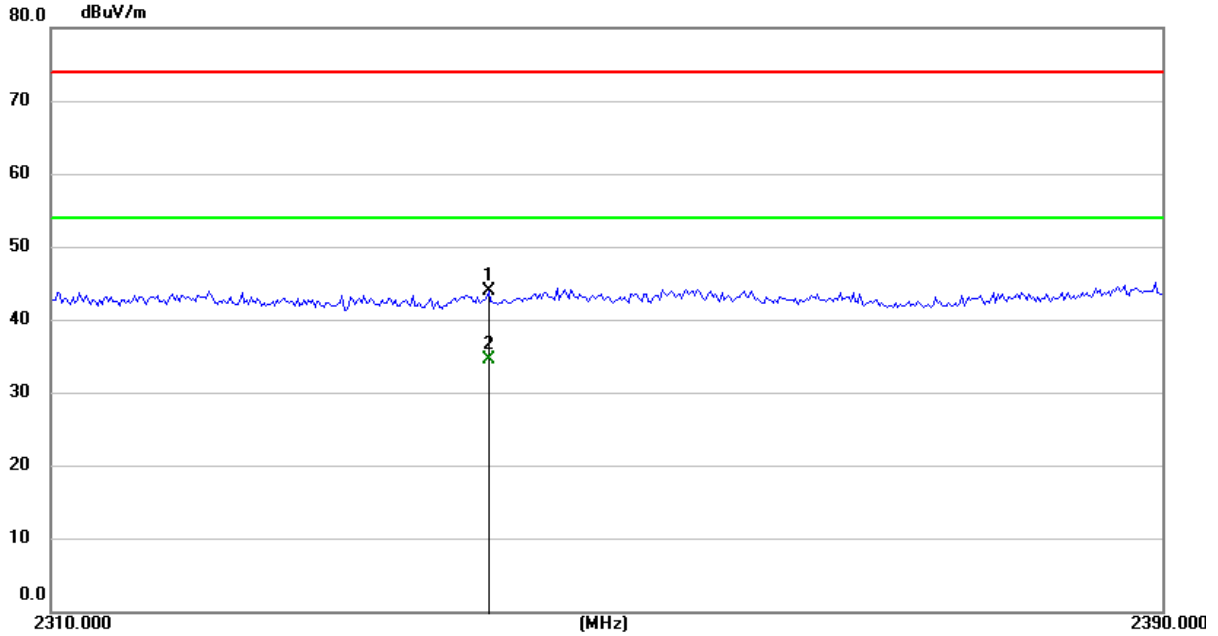

Test Model	Spurious Emission in Restricted Band 2310-2390MHz		
	Bluetooth V5.3 Channel 0: 2402MHz		
		GFSK	V
		Test By: Ken Zhao	

Model No.:	Y113S	Test Power :	DC 3.7V
Temperature:	26 °C	Humidity:	55 %

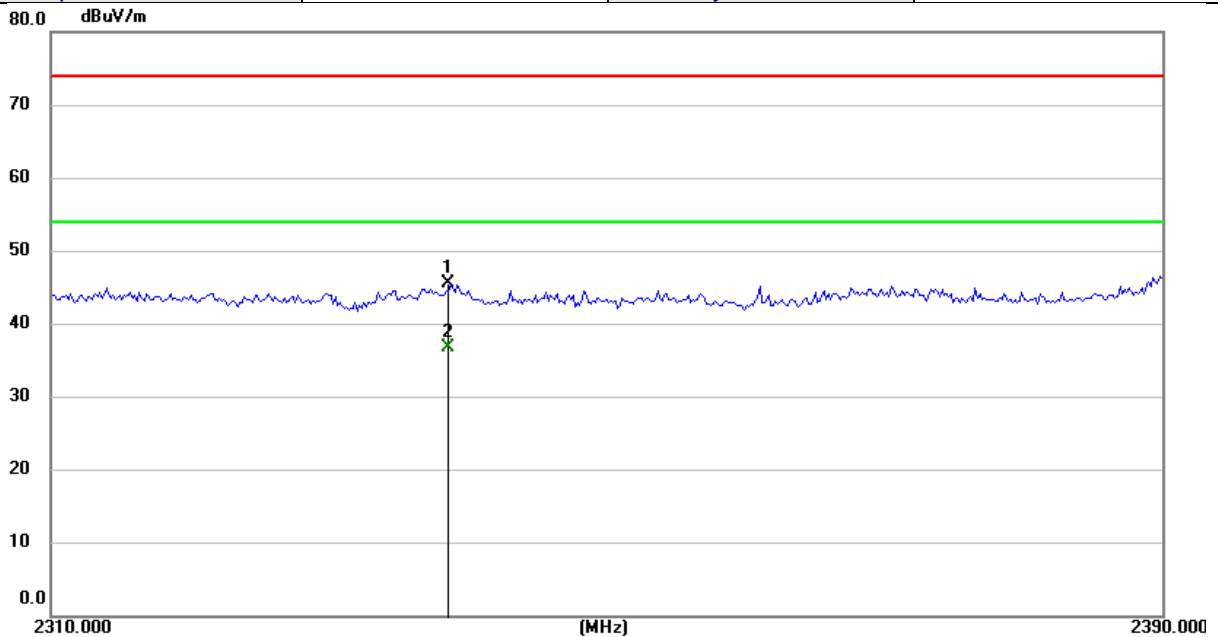

Test Model	Spurious Emission in Restricted Band 2483.5-2500MHz		
	Bluetooth V5.3		
	Channel 78: 2480MHz	GFSK	H
		Test By: Ken Zhao	

Model No.:	Y113S	Test Power :	DC 3.7V
Temperature:	26 °C	Humidity:	55 %

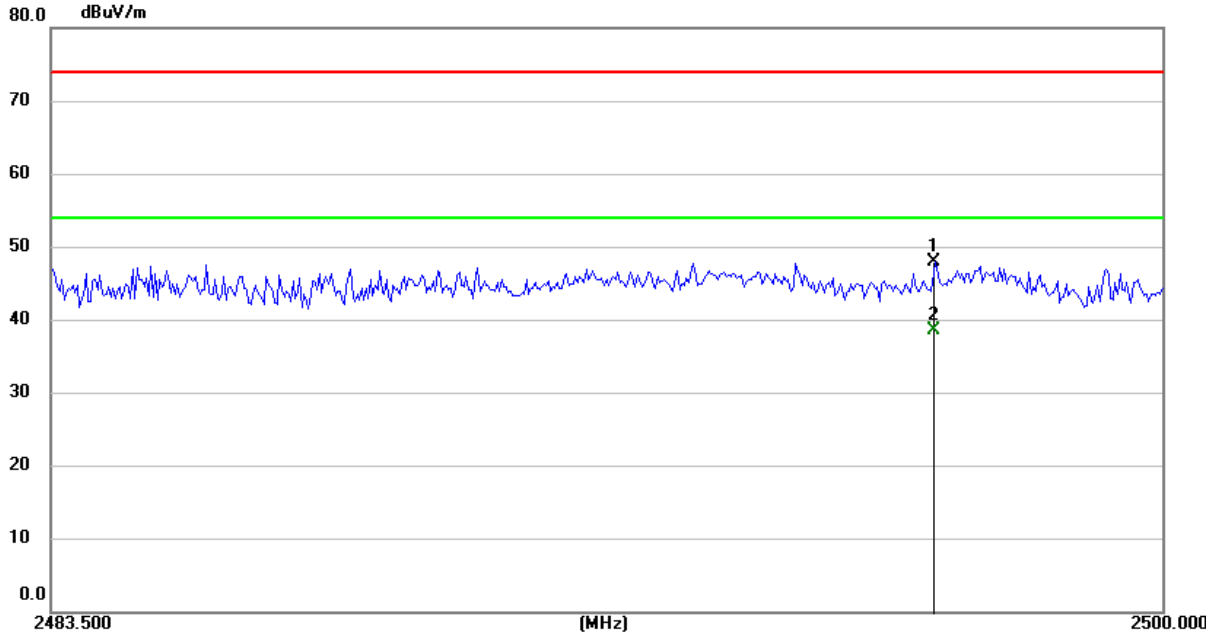

Test Model	Spurious Emission in Restricted Band 2483.5-2500MHz		
	Bluetooth V5.3		
	Channel 78: 2480MHz	GFSK	V
		Test By: Ken Zhao	

Model No.:	Y113S	Test Power :	DC 3.7V
Temperature:	26 °C	Humidity:	55 %

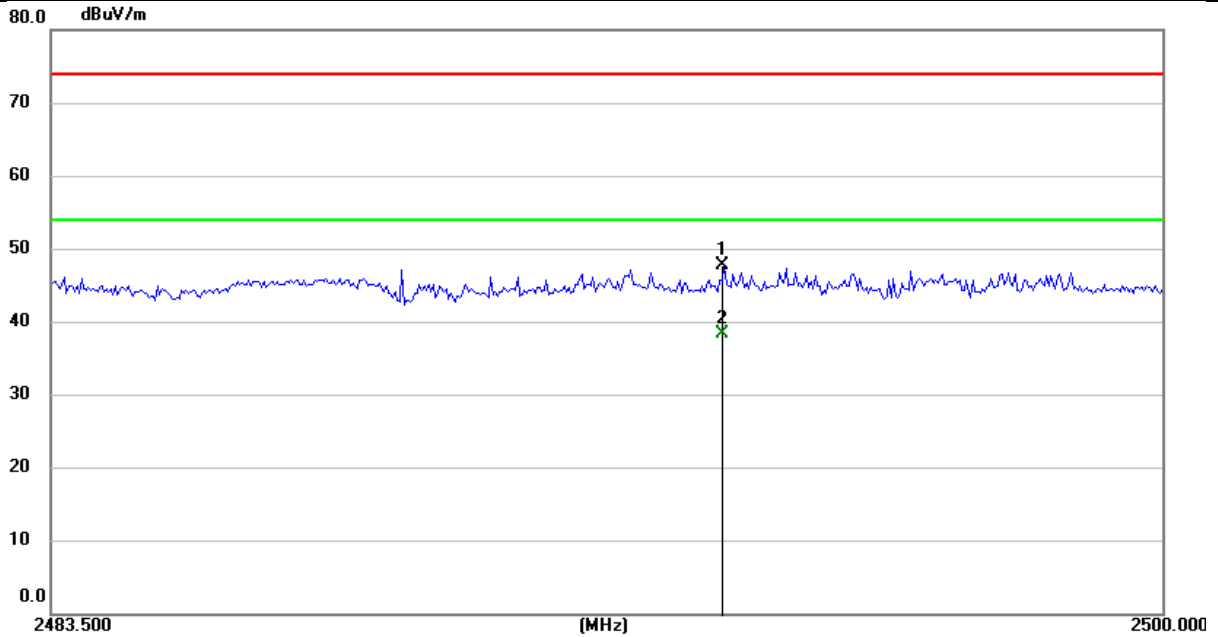

Test Model	Spurious Emission in Restricted Band 2310-2390MHz and 2400-2483.5MHz		
	Bluetooth V5.3 Hopping		
		GFSK	H
		Test By: Ken Zhao	

Model No.:	Y113S	Test Power :	DC 3.7V
Temperature:	26 °C	Humidity:	55 %

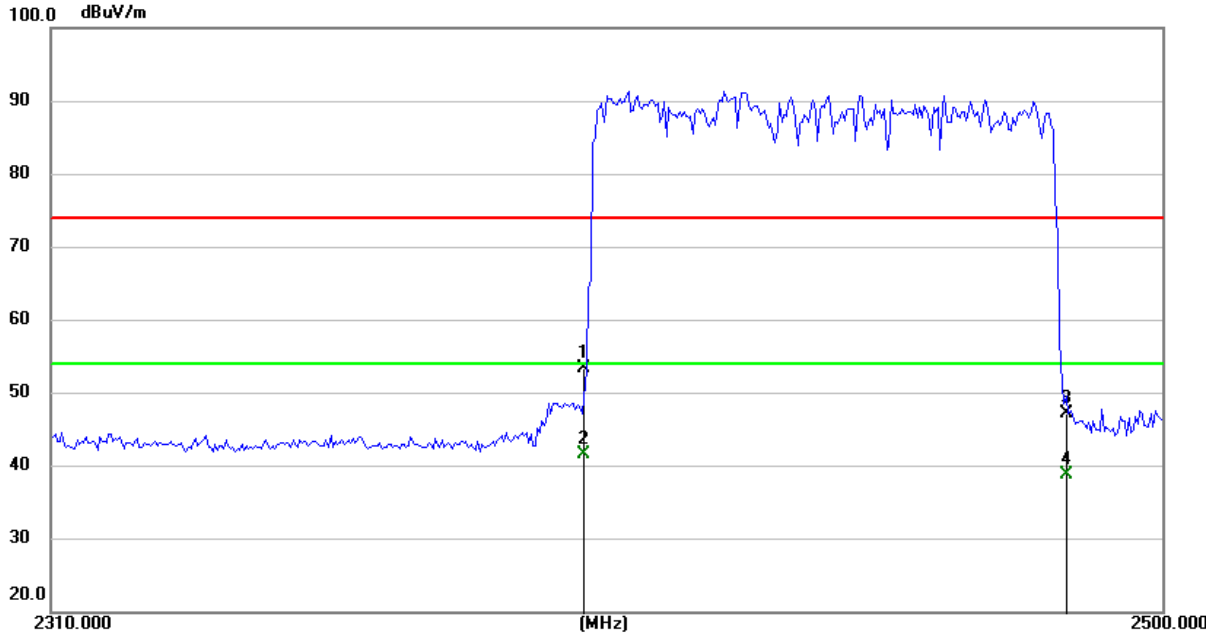

Test Model	Spurious Emission in Restricted Band 2310-2390MHz and 2400-2483.5MHz		
	Bluetooth V5.3 Hopping		
		GFSK	V
		Test By: Ken Zhao	

Model No.:	Y113S	Test Power :	DC 3.7V
Temperature:	26 °C	Humidity:	55 %

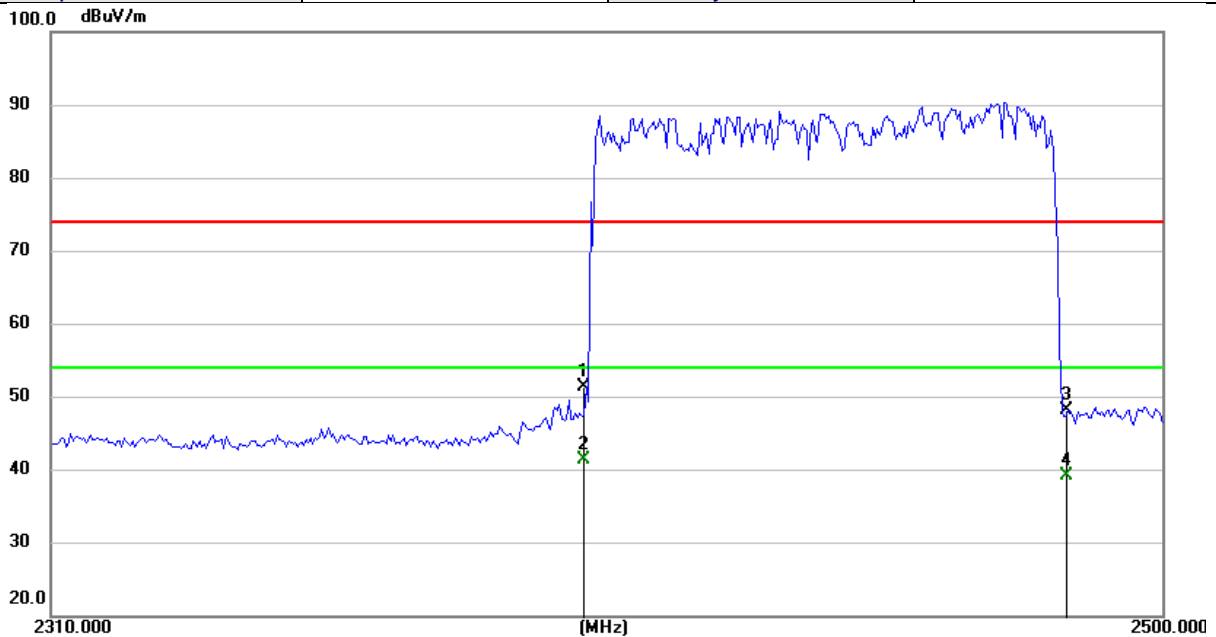

■ Spurious Emission below 1GHz (30MHz to 1GHz)
Bluetooth (GFSK, pi/4-DQPSK, 8DPSK) mode have been tested, and the worst result(GFSK) was report as below:

Model No.:	Y113S
Phase:	Vertical
Test Power :	DC 3.7V
Standard:	FCC Part15C Radiation(QP)
Operating Mode :	BT 2402

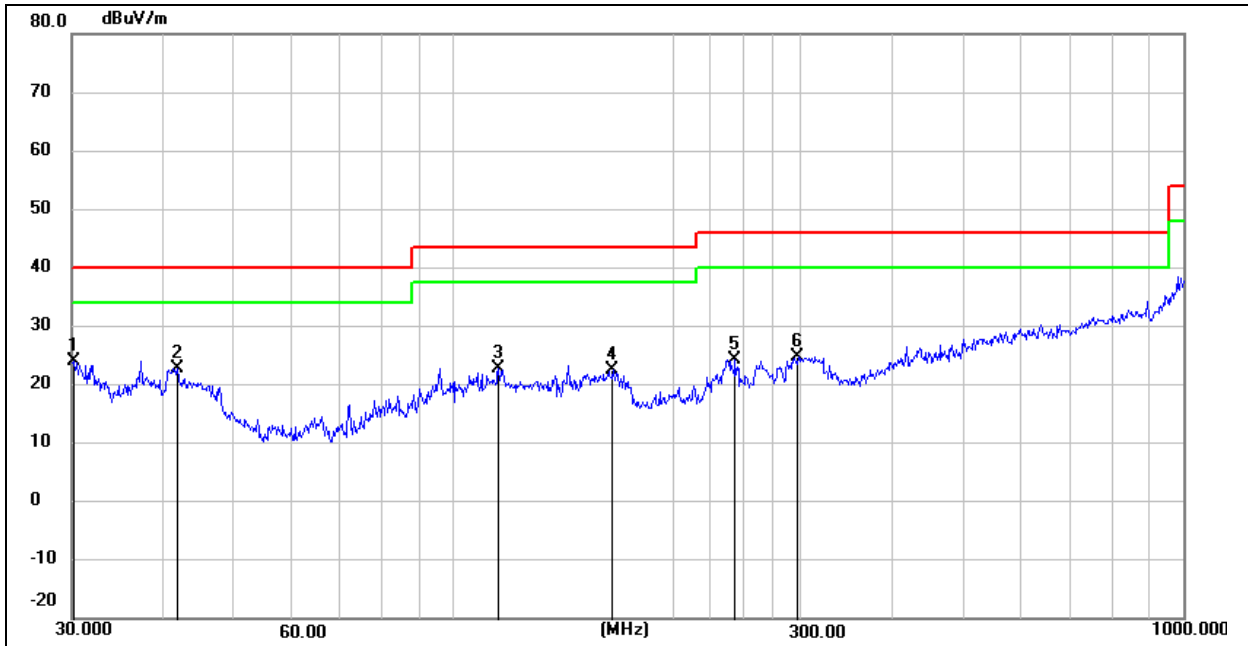

No.	Frequency (MHz)	Reading Level (dBuV)	Correct Factor (dB/m)	Emission Level (dBuV/m)	Limit (dBuV/m)	Margin (dB)	Remark			
1	30.210800	23.96	0.14	24.10	40.00	-15.90	peak			
2	41.859400	28.61	-5.75	22.86	40.00	-17.14	peak			
3	115.320400	26.43	-3.65	22.78	43.50	-20.72	peak			
4	165.486600	27.47	-4.90	22.57	43.50	-20.93	peak			
5	243.377100	28.54	-4.30	24.24	46.00	-21.76	peak			
6	297.223800	25.99	-1.17	24.82	46.00	-21.18	peak			

Model No.:	Y113S
Phase:	Horizontal
Test Power :	DC 3.7V
Standard:	FCC Part15C Radiation(QP)
Operating Mode :	BT 2402

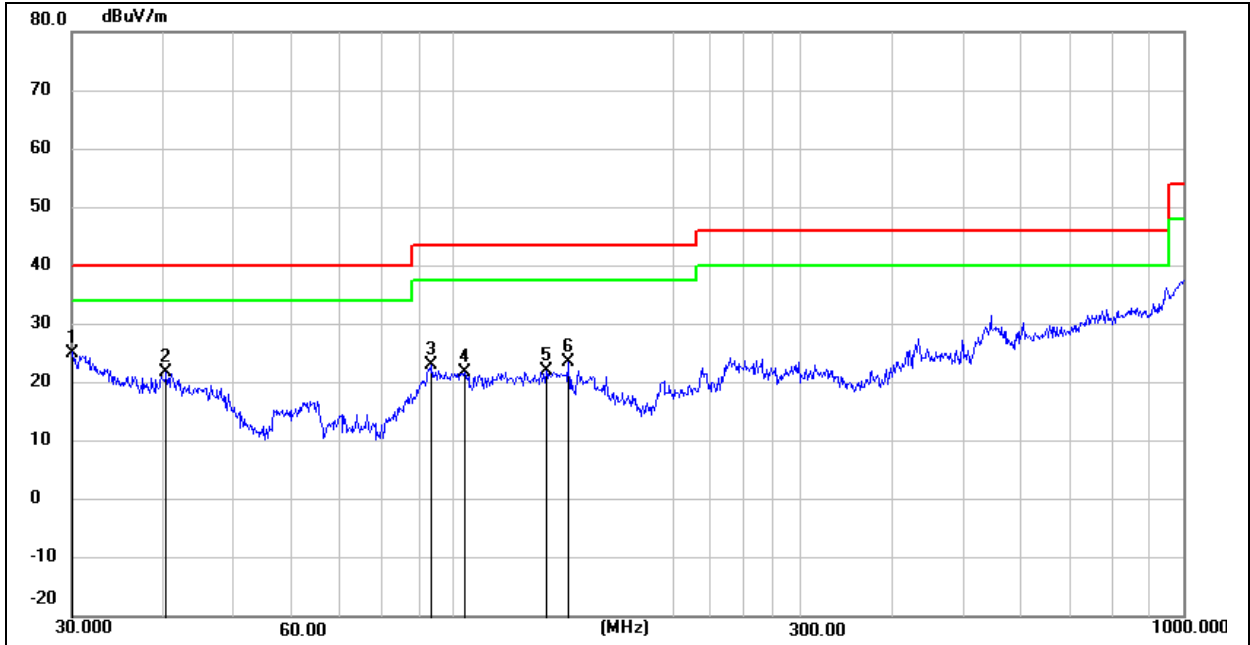

No.	Frequency (MHz)	Reading Level (dBuV)	Correct Factor (dB/m)	Emission Level (dBuV/m)	Limit (dBuV/m)	Margin (dB)	Remark			
1	30.105100	24.85	0.26	25.11	40.00	-14.89	peak			
2	40.417000	27.06	-5.20	21.86	40.00	-18.14	peak			
3	93.440200	30.37	-7.47	22.90	43.50	-20.60	peak			
4	103.805400	26.37	-4.55	21.82	43.50	-21.68	peak			
5	134.087700	24.95	-2.99	21.96	43.50	-21.54	peak			
6	143.829100	26.33	-2.91	23.42	43.50	-20.08	peak			

Model No.:	Y113S
Phase:	Vertical
Test Power :	DC 3.7V
Standard:	FCC Part15C Radiation(QP)
Operating Mode :	BT 2441

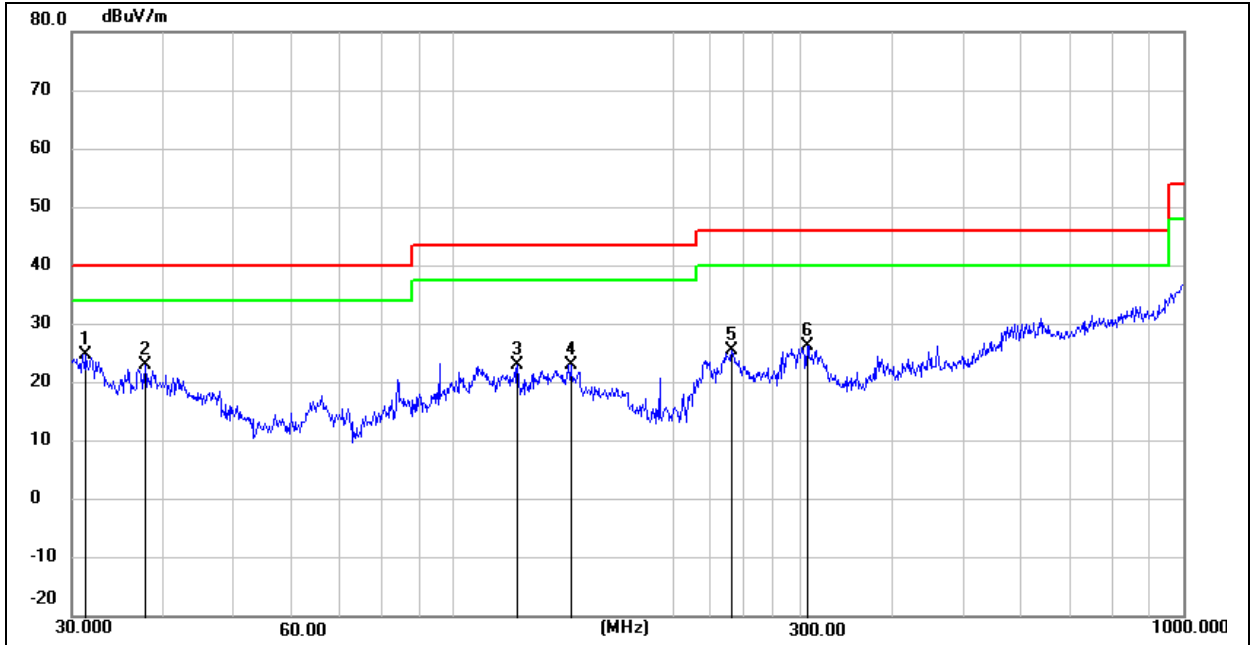

No.	Frequency (MHz)	Reading Level (dBuV)	Correct Factor (dB/m)	Emission Level (dBuV/m)	Limit (dBuV/m)	Margin (dB)	Remark			
1	31.399200	26.01	-1.15	24.86	40.00	-15.14	peak			
2	37.812100	28.11	-5.05	23.06	40.00	-16.94	peak			
3	122.403800	26.23	-3.20	23.03	43.50	-20.47	peak			
4	144.841700	26.02	-3.00	23.02	43.50	-20.48	peak			
5	240.830000	30.01	-4.62	25.39	46.00	-20.61	peak			
6	305.680000	27.81	-1.47	26.34	46.00	-19.66	peak			

Model No.:	Y113S
Phase:	Horizontal
Test Power :	DC 3.7V
Standard:	FCC Part15C Radiation(QP)
Operating Mode :	BT 2441

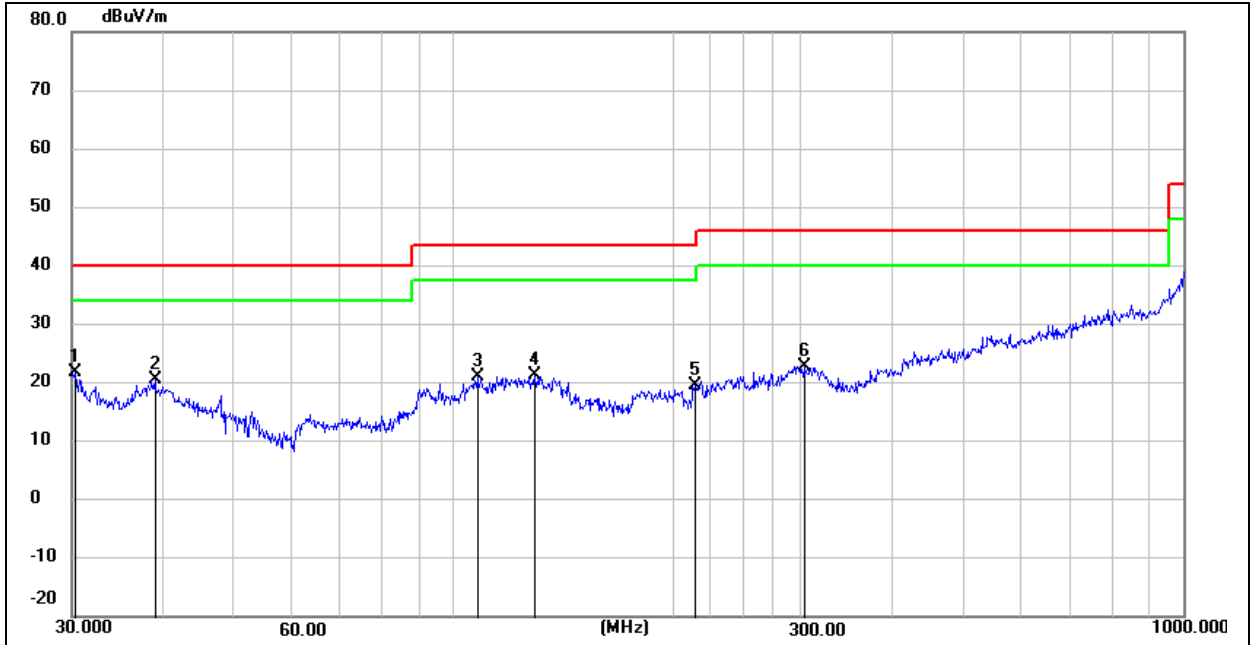

No.	Frequency (MHz)	Reading Level (dBuV)	Correct Factor (dB/m)	Emission Level (dBuV/m)	Limit (dBuV/m)	Margin (dB)	Remark			
1	30.317000	21.72	0.03	21.75	40.00	-18.25	peak			
2	39.024200	25.48	-5.03	20.45	40.00	-19.55	peak			
3	107.887600	25.37	-4.31	21.06	43.50	-22.44	peak			
4	129.467700	24.49	-3.26	21.23	43.50	-22.27	peak			
5	214.514100	26.40	-6.75	19.65	43.50	-23.85	peak			
6	302.481100	24.13	-1.33	22.80	46.00	-23.20	peak			

Model No.:	Y113S
Phase:	Vertical
Test Power :	DC 3.7V
Standard:	FCC Part15C Radiation(QP)
Operating Mode :	BT 2480

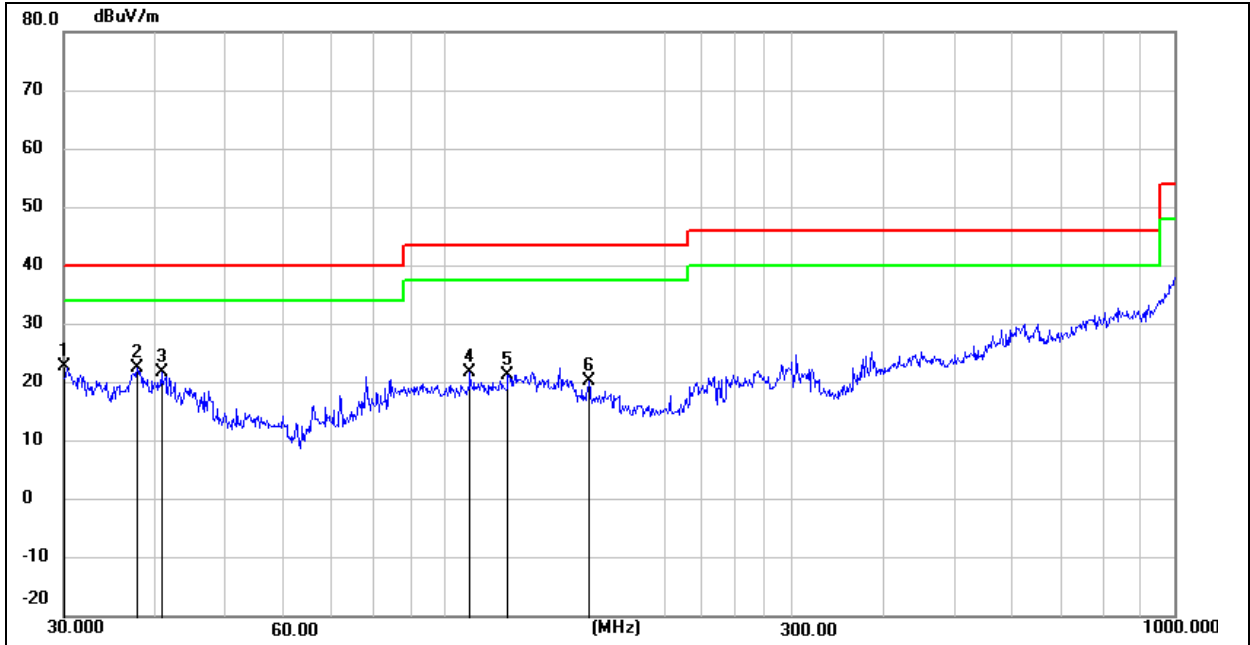

No.	Frequency (MHz)	Reading Level (dBuV)	Correct Factor (dB/m)	Emission Level (dBuV/m)	Limit (dBuV/m)	Margin (dB)	Remark			
1	30.000000	22.37	0.38	22.75	40.00	-17.25	peak			
2	37.812100	27.58	-5.05	22.53	40.00	-17.47	peak			
3	40.844400	27.11	-5.35	21.76	40.00	-18.24	peak			
4	108.266400	26.13	-4.28	21.85	43.50	-21.65	peak			
5	121.975300	24.54	-3.19	21.35	43.50	-22.15	peak			
6	157.558600	24.52	-4.22	20.30	43.50	-23.20	peak			

Model No.:	Y113S
Phase:	Horizontal
Test Power :	DC 3.7V
Standard:	FCC Part15C Radiation(QP)
Operating Mode :	BT 2480

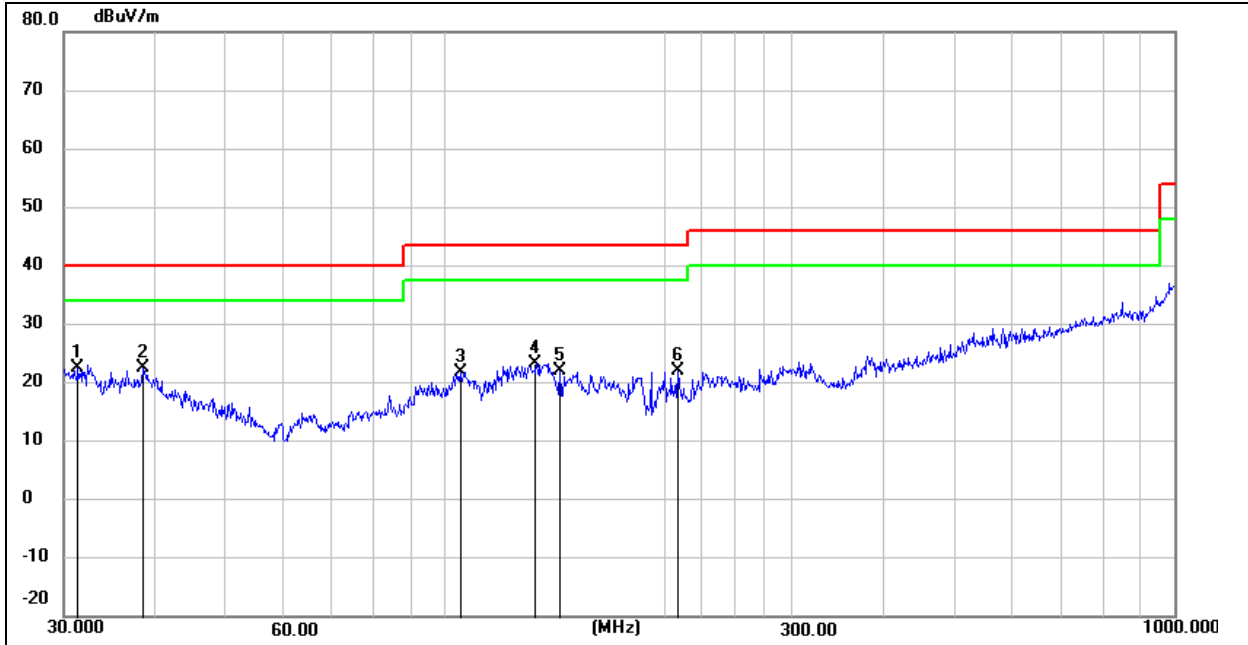

No.	Frequency (MHz)	Reading Level (dBuV)	Correct Factor (dB/m)	Emission Level (dBuV/m)	Limit (dBuV/m)	Margin (dB)	Remark			
1	31.399200	23.56	-1.15	22.41	40.00	-17.59	peak			
2	38.480800	27.49	-5.04	22.45	40.00	-17.55	peak			
3	104.903000	26.36	-4.48	21.88	43.50	-21.62	peak			
4	133.618400	26.25	-3.02	23.23	43.50	-20.27	peak			
5	143.829200	25.04	-2.91	22.13	43.50	-21.37	peak			
6	208.580000	28.94	-6.89	22.05	43.50	-21.45	peak			

7.8 CONDUCTED EMISSION TEST

7.8.1 Applicable Standard

According to FCC Part 15.207(a)

7.8.2 Conformance Limit

Conducted Emission Limit		
Frequency(MHz)	Quasi-peak	Average
0.15-0.5	66-56	56-46
0.5-5.0	56	46
5.0-30.0	60	50

Note: 1. The lower limit shall apply at the transition frequencies
 2. The limit decreases in line with the logarithm of the frequency in the range of 0.15 to 0.50MHz.

Remark: Test results were obtained from the following equation:

$$\text{Measurement (dB}\mu\text{V)} = \text{LISN Factor (dB)} + \text{Cable Loss (dB)} + \text{Reading (dB}\mu\text{V)}$$

$$\text{Margin (dB)} = \text{Measurement (dB}\mu\text{V)} - \text{Limit (dB}\mu\text{V)}$$

7.8.3 Test Configuration

Test according to clause 6.3 conducted emission test setup

7.8.4 Test Procedure

The EUT was placed on a table which is 0.8m above ground plane.
 Maximum procedure was performed on the highest emissions to ensure EUT compliance.
 Repeat above procedures until all frequency measured were complete.

7.8.5 Test Results

DC products are not applicable

7.9 ANTENNA APPLICATION

7.9.1 Antenna Requirement

Standard	Requirement
FCC CRF Part 15.203	An intentional radiator shall be designed to ensure that no antenna other than that furnished by the responsible party shall be used with the device. The use of a permanently attached antenna or of an antenna that uses a unique coupling to the intentional radiator shall be considered sufficient to comply with the provisions of this section. The manufacturer may design the unit so that a broken antenna can be replaced by the user, but the use of a standard antenna jack or electrical connector is prohibited. This requirement does not apply to carrier current devices or to devices operated under the provisions of §15.211, §15.213, §15.217, §15.219, or §15.221. Further, this requirement does not apply to intentional radiators that must be professionally installed, such as perimeter protection systems and some field disturbance sensors, or to other intentional radiators which, in accordance with §15.31(d), must be measured at the installation site. However, the installer shall be responsible for ensuring that the proper antenna is employed so that the limits in this part are not exceeded.

For intentional device, according to FCC 47 CFR Section 15.203, an intentional radiator shall be designed to ensure that no antenna other than that furnished by the responsible party shall be used with the device. And according to FCC 47 CFR Section 15.247 (b), if transmitting antennas of directional gain greater than 6dBi are used, the power shall be reduced by the amount in dB that the directional gain of the antenna exceeds 6dBi.

7.9.2 Result

PASS.

The EUT has 1 antenna: Chip Antenna for BT V5.3 with classic model, the gain is 2.7 dBi;

Note: Antenna use a permanently attached antenna which is not replaceable.
 Not using a standard antenna jack or electrical connector for antenna replacement
 The antenna has to be professionally installed (please provide method of installation)

which in accordance to section 15.203, please refer to the internal photos.

----- END OF REPORT -----

声明 Statement

1. 本报告无授权批准人签字无效;

This report will be void without authorized signature for testing report.

2. 未经许可本报告不得部分复制;

This report shall not be copied partly without authorization.

3. 本报告的检测结果仅对送测样品有效, 委托方对样品的代表性和资料的真实性负责;

The test results or observations are applicable only to tested sample. Client shall be responsible for representativeness of the sample and authenticity of the material.

4. 本检测报告中检测项目标注有特殊符号则该项目不在资质认定范围内, 仅作为客户委托、科研、教学或内部质量控制等目的使用;

The observations or tests with special mark fall outside the scope of accreditation, and are only used for purpose of commission, research, training, internal quality control etc.

5. 本检测报告以实测值进行符合性判定, 未考虑不确定度所带来的风险, 本实验室不承担相关责任, 特别约定、标准或规范中有明确规定的除外;

The test results or observations are provided in accordance with measured value, without taking risks caused by uncertainty into account. Without explicit stipulation in special agreements, standards or regulations, SLG-CPC shall not assume any responsibility.

6. 对本检测报告若有异议, 请于收到报告之日起 20 日内提出;

Objections shall be raised within 20 days from the date receiving the report.