

Company : Dongguan Desinda Electronic Technology Co.,Ltd.  
Address : Room 202, No. 191 Tai'an Road, Wei Town,  
Zhangmutou Town, Dongguan City, Guangdong Province

---

客户/Ciient RITS ELECTRONICS(SHENZHEN)CO., LTD.

名称/TYPE Wireless charging coil

产品型号

Model NO

MP-A2/G50 \* 0.8 magnetic sheet with holes and double grooves,  
adhesive line length 30MM10UH

产品编号

DXD202406002

Part numbering systey

客户料号

4Z2-00-0020

Cient p/NO

工程编号

Enginrer NO

日期/Date

2024-6-27

本公司工程部/For Enginer Departner Only	
修改内容/Rvised Cintent	认可日期/APProved Date

编制/Prepared

RAO

审核/Checked

Xie Liang

认可/Approved

XU YAN

客户认可回签/Authorixed Signaturure Company Chop		
工程/ Enginrer	认可/QC APProved	认可日期/APProved

## 一、线圈工艺/Winding Procese:

NO	Winding	Wire gauge	Number of turns	Winding direction	Notes
1	N1	2UEW-B-0.08*105P	12TS	CCW	
2					

## 二 . 电气性能/FEATURES:

1.测试条件 ( Test conditions ) : 25°C,65%RH@100KHz/1V

1.1 电感量 ( Inductance )

1.11 L0A(Coil+Magnetic Disc)=10uH±10%

1.2 Q price =85MIN

1.3 DC Resistance ( DCR ) : 85mΩ MAX

1.4 工作温度(Operating Temperature) : -25°C~85°C

2.测试仪器(Test instrument) : L:1068+1310;DCR:502BC;SIZE:Callipers

3.材料清单(Bill of Material)

NO	Project	Material
1	WIRE	φ 0.08*105p 2UEW-1.15mm
2	FERRITE	50*5.3*0.8 Ferrite hard magnet
3	GLUE	White glue
4	SOLDER	XCD-907B
5	Adhesive	Adhesive backing
6	High temperature adhesive	3MMHigh temperature adhesive tape
7		
8		

### 三 . 参考图/CIRCUIT DIAGRAM



Unit: MM

### 四 . 外形图/OUTSIDE DIAGRA

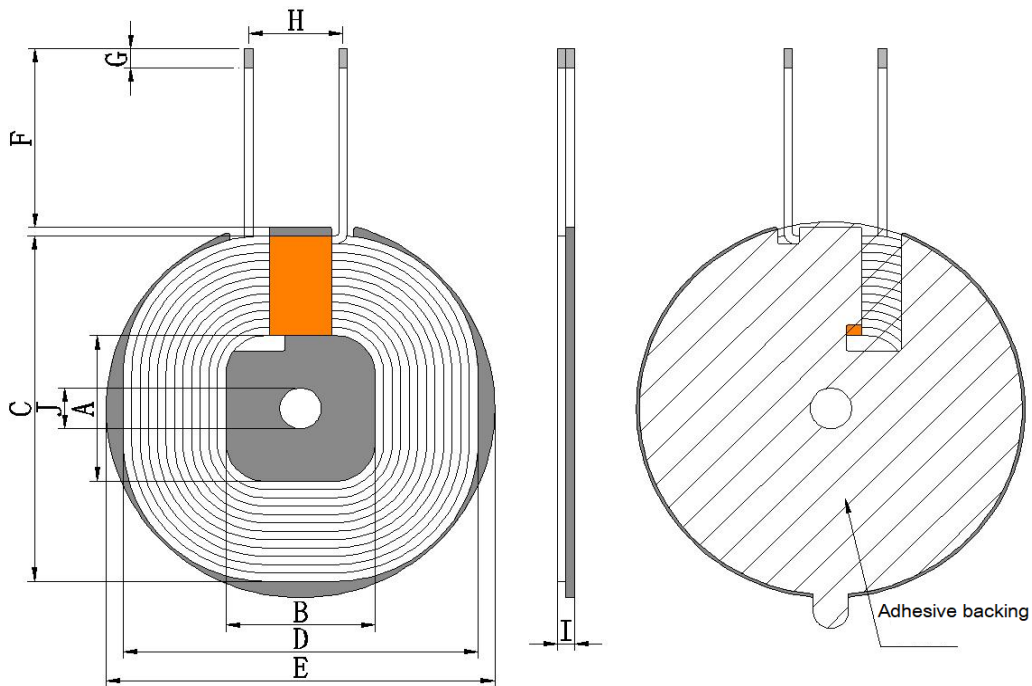

Note: Wrap 7MM (ref) high-temperature adhesive tape around the coil outlet position

Standard	A	B	C	D	E	F	H	G	J	I
STD	19.5±1	19.5±1	44.5±1	43.5±1	49.5±1	30±2	15MAX	2-5	5.3±0.5	2.5Max