

SPECIFICATION FOR APPROVAL

1. MECHANICAL DIMENSION (UNIT:mm)

2. SCHEMATICS:

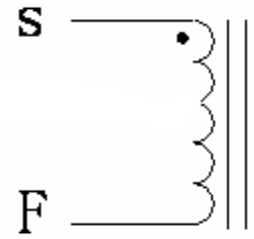
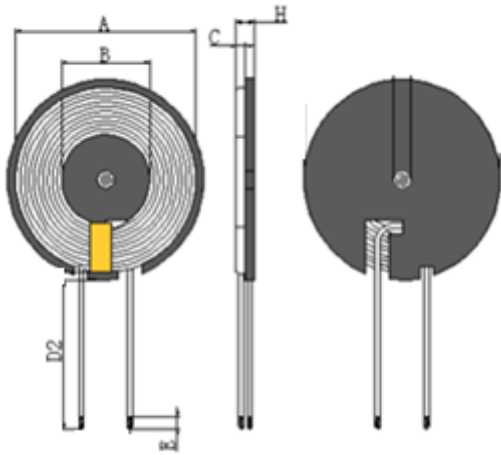

A	B	C	D2	E	H			I
50±1.0	20.5±0.5	0.8±0.05	42±3	3±1.5	2.6MAX			

3. WINDING:

STEP	START-FINISH	WIRE TYPE	TURNS	TAP E	REMARK
N1	S-F	silk-covered wire 2UEW	10TS (Ref)		

4. ELECTRICAL SPECIFICATION:

ITEM	L	DCR		Qvalue	HI-POT
TEST	The coil was added with a magnetic	S-F			
COND	100KHz, 0.25V	AT 25°C			
SPEC	6.3uH±10%	75mΩ Max			