

TTC 3018S

Note: The picture is for reference only, the actual product shall prevail



RoHS



LETTER FROM TWOTREES 致客户的一封信

Dear Customers,

Thank you for choosing us.

It's customer-oriented idea, continuous innovation and pursuit of excellence that enable everybody to have wonderful experience in using process.

We believe that this manual will be helpful.

Hope you enjoy the good time with TwoTrees.

If you have any problems, please feel free to contact us via:

Website: www.twotrees3d.com

Facebook: <https://www.facebook.com/groups/twotrees3Dprinter/>

For general inquiry: info@twotrees3d.com

For technical support: service@twotrees3d.com

We will contact you within 24 hours.

Sincerely yours,

TwoTrees Team

亲爱的客户：

感谢您选择了我们品牌。

我们一直以客户为导向，不断创新，追求卓越，使每个人都能在使用过程中拥有丰富的体验。

希望您能享受与俩棵树相伴的好时光。

如果您有任何问题，请随时与我们各购买平台的客服联系。

其他联系渠道有：

网站： www.twotrees3d.com

售后邮箱： service@twotrees3d.com

咨询邮箱： info@twotrees3d.com

我们将在24小时内联系上您。

祝您生活愉快！

俩棵树团队

CONTENTS/目录

Know Your Engraving Machine -----	01
(了解您的雕刻机)	
Part List -----	02
(配件表)	
Machine Parameters -----	03
(机器参数)	
Assembly Step -----	04
(安装步骤)	
Motherboard Description -----	11
(主板说明)	
Instruction of Mainboard Wiring -----	12
(主板接线说明)	
Installation of milling cutter -----	14
(铣刀的安装)	
Clamping screw installation -----	15
(夹紧螺丝安装)	
Operation Guide -----	16
(操作指南)	
After-Sales Service -----	20
(售后服务)	

KNOW YOUR ENGRAVING MACHINE

了解您的雕刻机

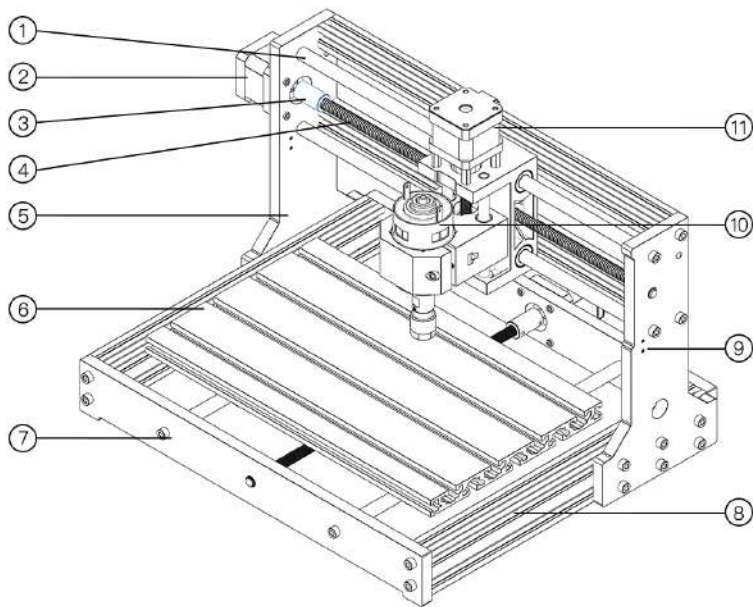

1. X-axis D10 polished rod / X轴D10光轴
2. X-axis 42 step motor / X轴42步进电机
3. Rigid coupling / 刚性联轴器
4. X-axis T8-4 Screw / X轴丝杆 (T8导程4)
5. Left-side plate / 左侧板
6. Y-axis engraving platform / Y轴雕刻平台
7. Front-side plate / 前侧板
8. 2040 side profile / 2040侧边型材
9. Right-side plate / 右侧板
10. 775 spindle motor / 775主轴电机
11. Z-axis 42 step motor / Z轴42步进电机

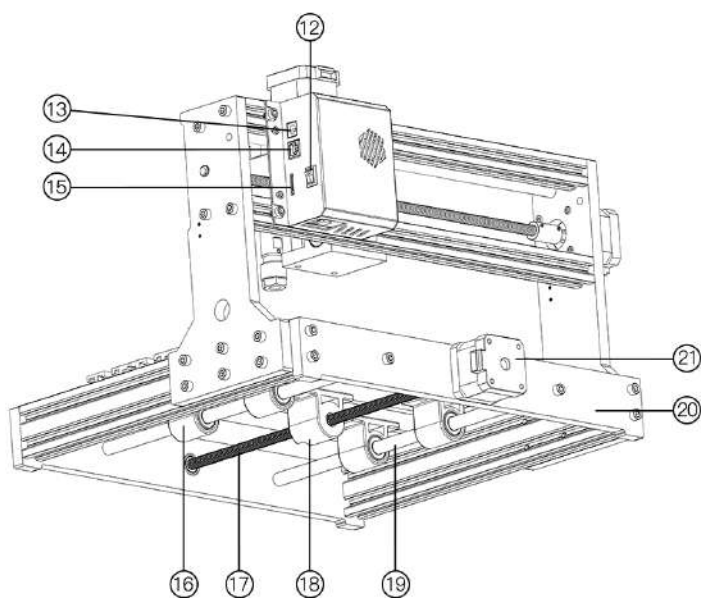

12. Power switch / 电源开关
13. DC power interface / DC电源接口
14. USB interface / USB接口
15. TF card slot / TF卡槽
16. Y polished rod slider / Y轴光滑块
17. Y-axis T8-4 screw / Y轴丝杆 (T8导程4)
18. Y-axis T8 screw holder / Y丝杆螺母座
19. Y-axis D10 polished rod / Y轴D10光轴
20. Back baffle / 后挡板
21. Y-axis 42 step motor / Y轴42步进电机

PARTS LIST/配件清单

<p>1 </p> <p>Profile/型材 (360mm) X 2</p>	<p>2 </p> <p>Polished rod/光轴 (360mm) X 2</p>	<p>3 </p> <p>Screw/丝杆 T8-4*360 (X-axis/X轴) X 1</p>	<p>4 </p> <p>Screw/丝杆 (Y-axis/Y轴) X 1</p>
<p>5 </p> <p>Left-side plate 左侧板 X 1</p>	<p>6 </p> <p>Right-side plate 右侧板 X 1</p>	<p>7 </p> <p>Z axis module Z轴模组 X 1</p>	<p>8 </p> <p>Power adapter 电源适配器 X 1</p>
<p>9 </p> <p>Matherboard module 主板组件 X 1</p>	<p>10 </p> <p>M5*25 X 12</p>	<p>11 </p> <p>M5*16 X 8</p>	<p>12 </p> <p>M4*12 X 4</p>
<p>13 </p> <p>M3*6 X 4</p>	<p>14 </p> <p>M3*14 X 8</p>	<p>15 </p> <p>USB line 数据线 X 1</p>	<p>16 </p> <p>Motor module 电机组件 X 2</p>
<p>17 </p> <p>Base 底座 X 1</p>	<p>18 </p> <p>ER11 spindle motor chuck ER11 主轴电机夹头 X 1</p>	<p>19 </p> <p>Clamping screw package 装夹螺丝包 X 1</p>	<p>20 </p> <p>Power cable 电源线 X 1</p>
<p>21 </p> <p>Toolkit 工具包 X 1</p>	<p>22 </p> <p>Wire bag 线材包 X 1</p>	<p>23 </p> <p>Matherboard cover 主板外罩 X 1</p>	

MACHINE PARAMETERS/机器参数

Support software (支持软件)	Candle
Applicable carving materials (适用雕刻材料)	Wood+plastic+aluminum plate+brass+acrylic (木材+塑料+铝板+黄铜+亚克力)
Engraving range (雕刻范围)	300*180*40mm
Machine size (机器尺寸)	420*355*280mm
Spindle parameters (主轴参数)	775 spindle motor (12-24V) : 7000r/min, 9000r/min (775主轴电机)
Stepper motor torque (步进电机扭矩)	1.3A 0.25N.m
Power supply (电源供应)	24V 4A
Support system (支持系统)	Windows XP / Win 7 / Win 8 / Win10 Home version (家庭版)
Drill bits (钻头)	Diameter: 3.175mm, tip:0.1mm, length:30mm

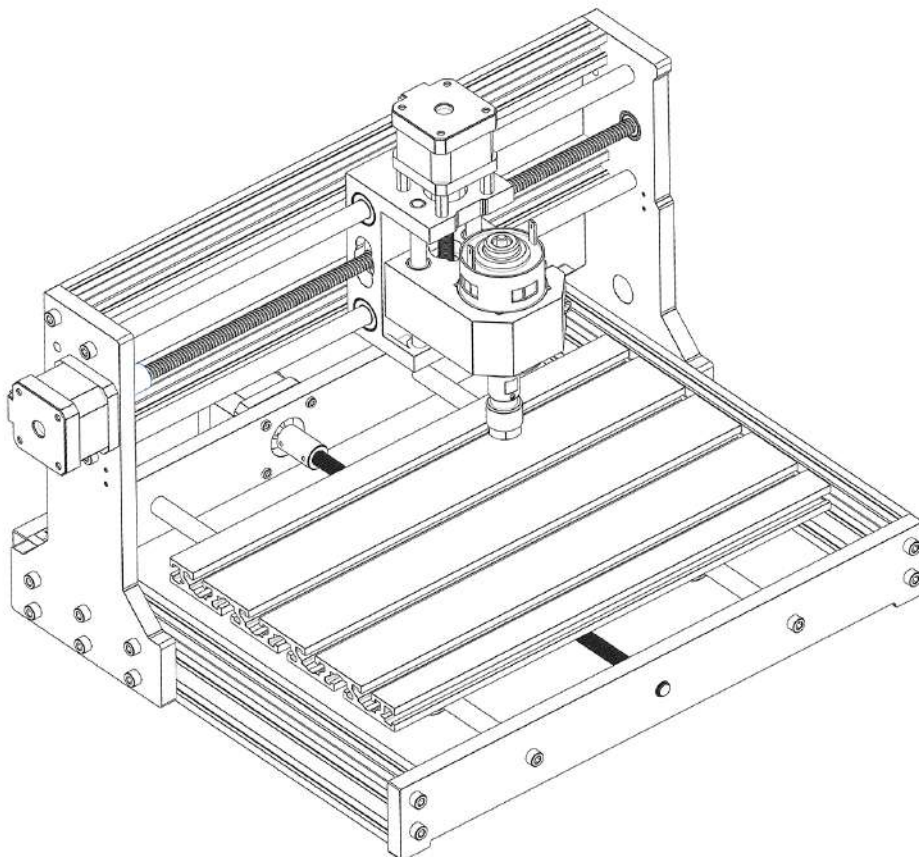

1. Installation of base, screw rod and Y-axis motor/ 底座与丝杆以及Y轴电机组件安装

1.1. Installation of base screw/底座丝杆的安装

Pass the screw rod through the motor through hole of the rear side plate, align the Y-axis screw rod holder and rotate clockwise to the front side plate bearing hole and flush with the front side plate (to facilitate the installation of the motor in the next step).

将丝杆穿过后侧板的电机过孔，对准Y轴丝杆固定座并且顺时针旋转至前侧板轴承孔并与前侧板平齐（便于下一步电机的安装）。

Use/使用: Base/底座 1pcs

Screw/丝杆 L=300MM (Y axis/Y轴) 1pcs

Brass nut/黄铜螺母 1pcs

Spring/弹簧 1pcs

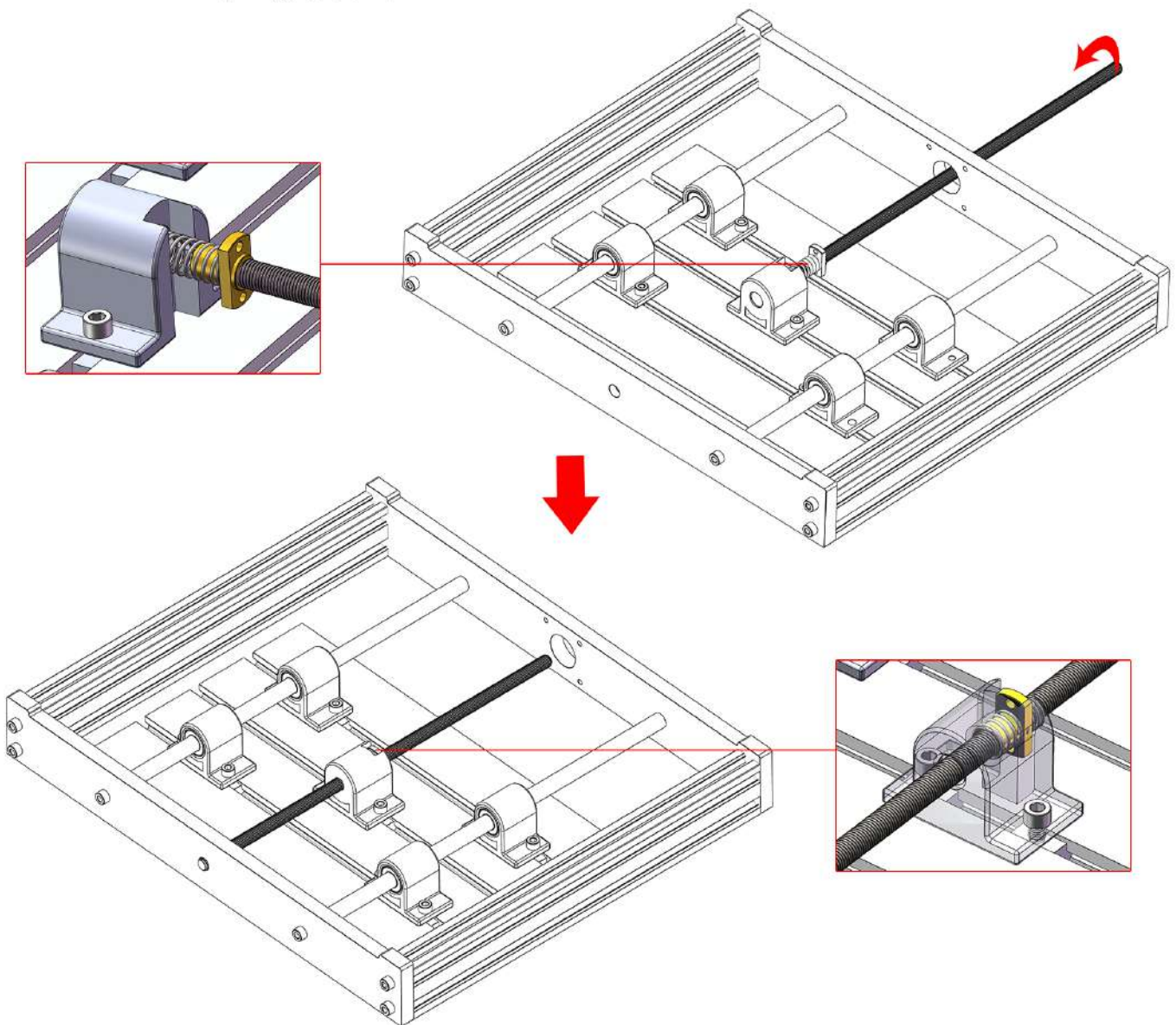

Note: ①If you don't understand, please refer to 15 Page Brass nut and spring installation drawing.

②When locking, you need to pay attention to whether the screw rotation is smooth.

注意: ①不明白之处参考15页黄铜螺母以及弹簧安装示意图

②锁紧时需要注意丝杆转动是否顺畅

1.2. Installation of Y-axis motor of base/底座Y轴电机的安装

Use/使用: M3*14 4pcs

42 step motor components/42步进电机组件 1pcs

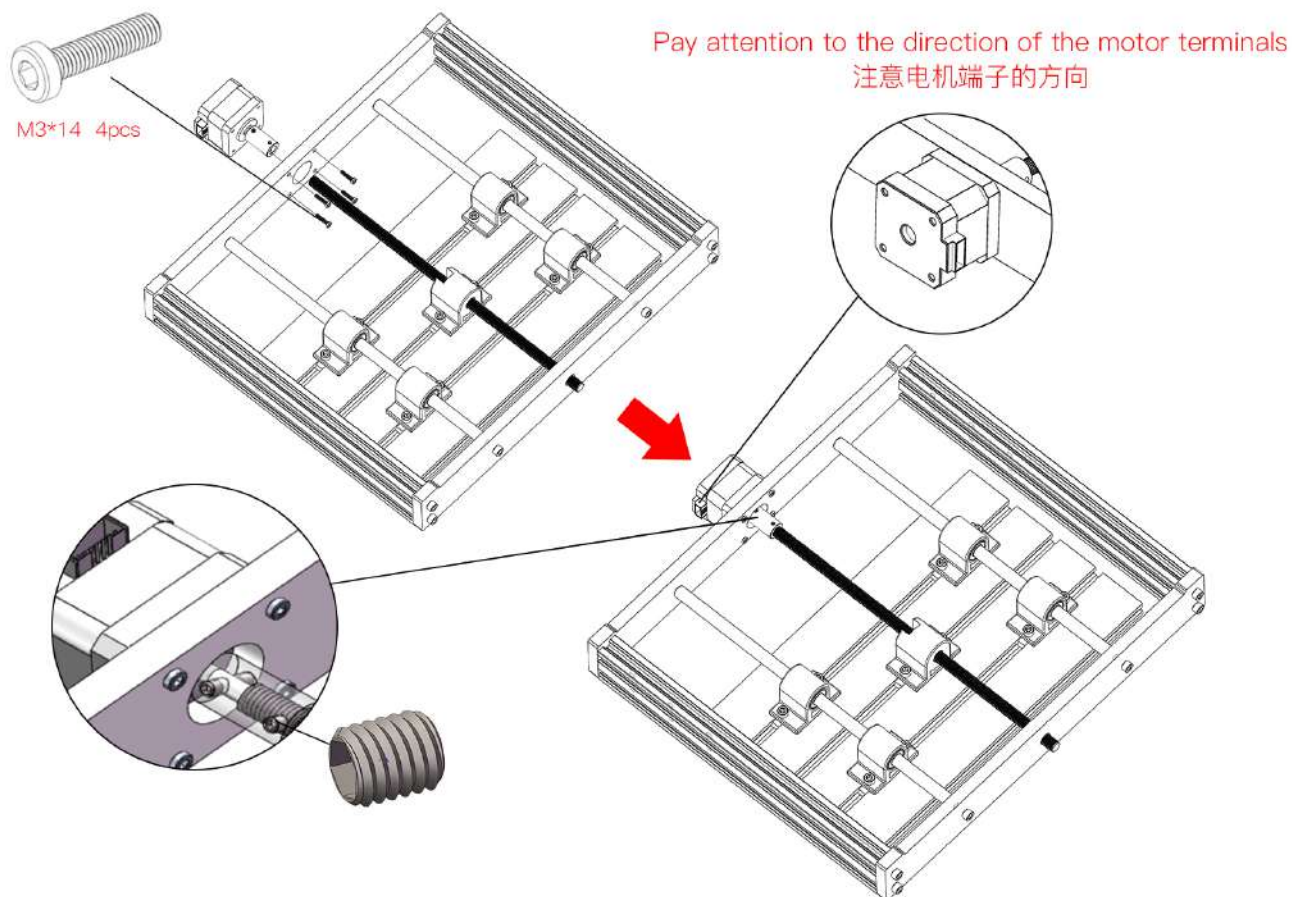

Assemble the motor and the screw rod, the screw rod and the motor shaft can be contacted to lock the top screw of the rigid coupling.
电机与丝杆装配注意，丝杆和电机轴接触即可锁紧刚性联轴器上顶丝。

1.3. Tighten the screw of the screw holders of the Y-axis engraving platform 锁紧Y轴雕刻平台的丝杆固定座螺丝

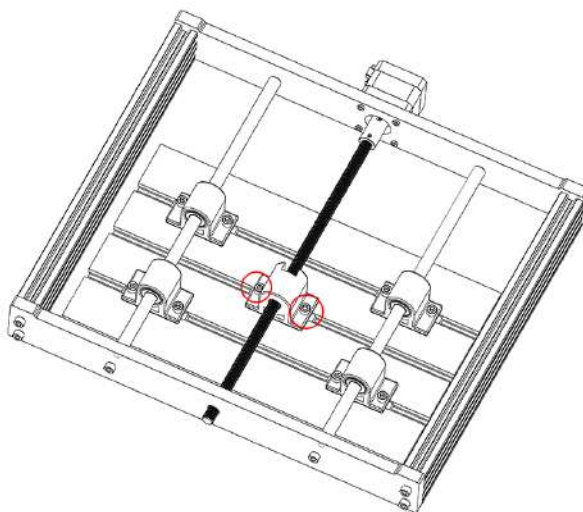

Note: When locking, you need to pay attention to whether the screw rotation is smooth
注意：锁紧时需要注意丝杆转动是否顺畅

2. Installation of the left-side plate/ 左侧板的安装

Use/使用: M5*25 6pcs

Left side board/左侧板 1pcs

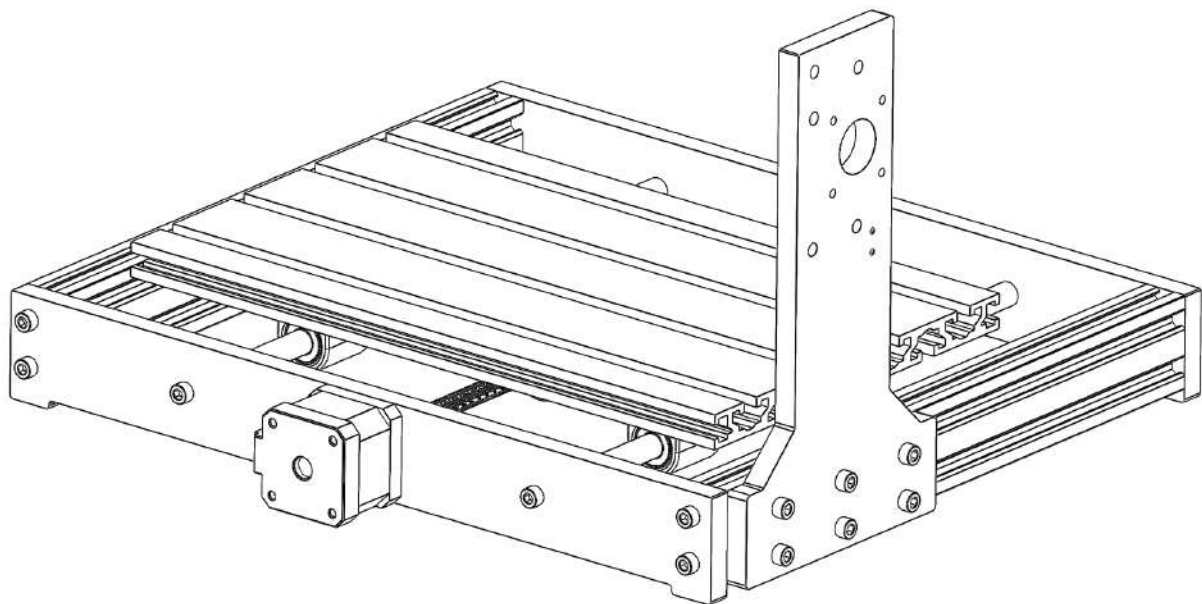
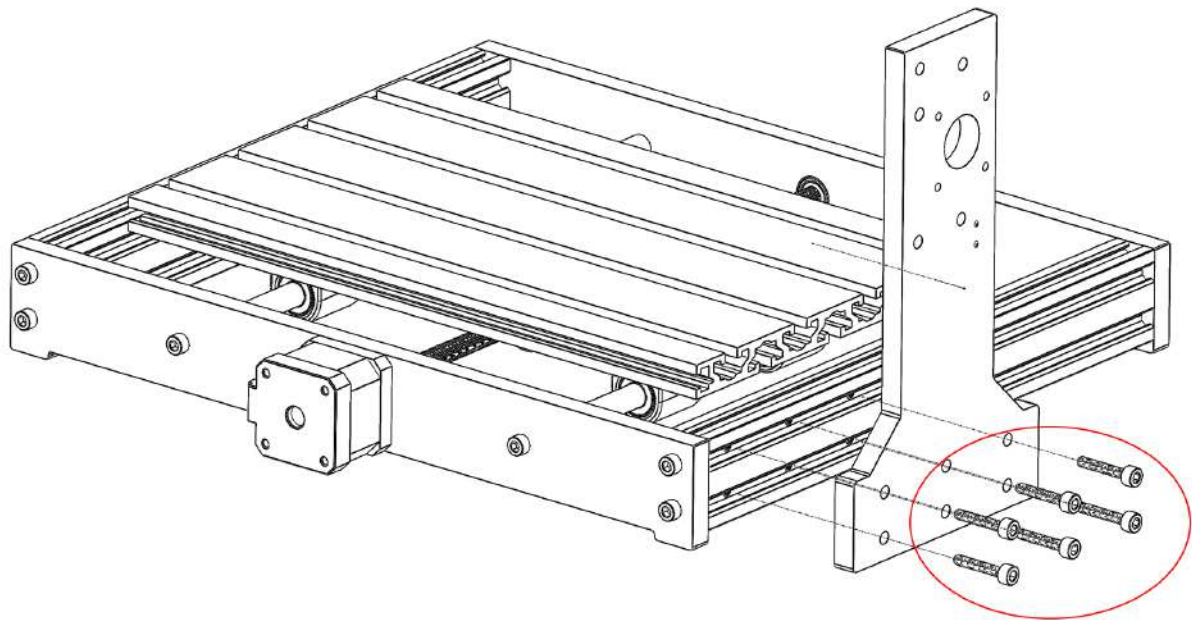

3. Installation of X-axis profile beam/ X轴型材横梁的安装

Use: Profile/型材 2pcs

M5*16 2pcs

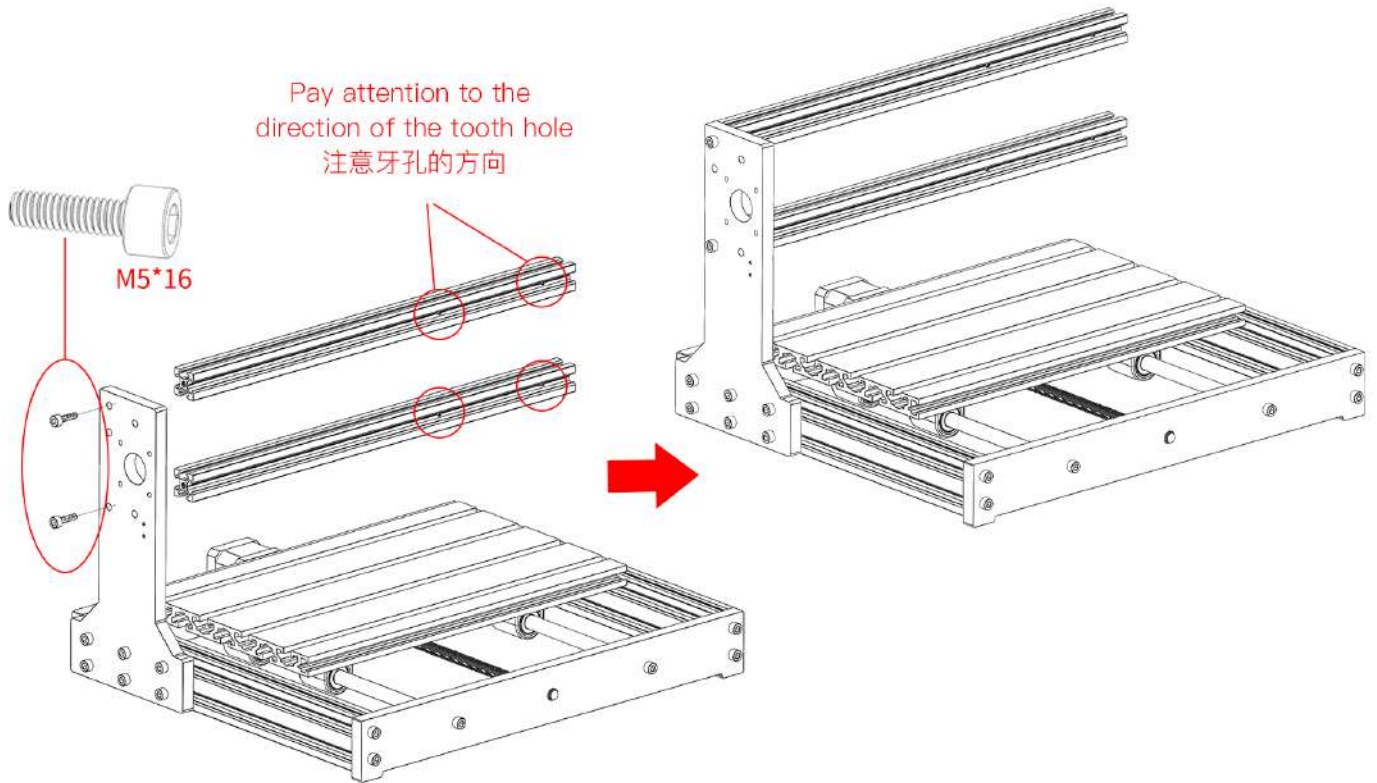

4. Installation of X-axis D10 polished rod/ X轴光轴的安装

Use/使用: M5*16 2pcs

X-axis D10 polished rod / X轴D10光轴 2pcs

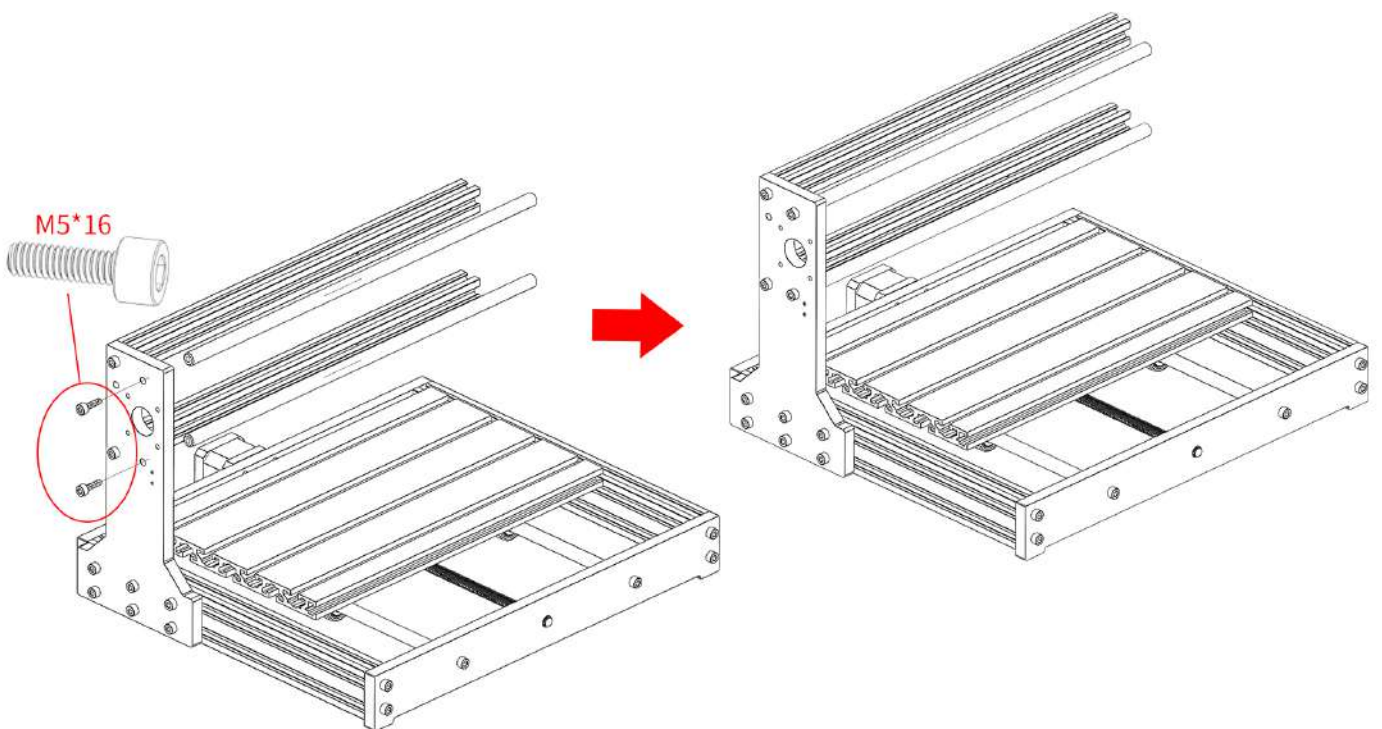

5. Installation of Z-axis module/Z轴模块的安装

Align the optical axis installation hole of the Z-axis module with the optical axis and insert it, and slide it back and forth to check whether the Z-axis module is stuck or not smooth.
将Z轴模组光轴安装孔对准光轴套入进去，来回滑动来检查Z轴模组是否有卡顿或者不顺畅。

Use/使用: Z axis module/Z轴模组 1PCS

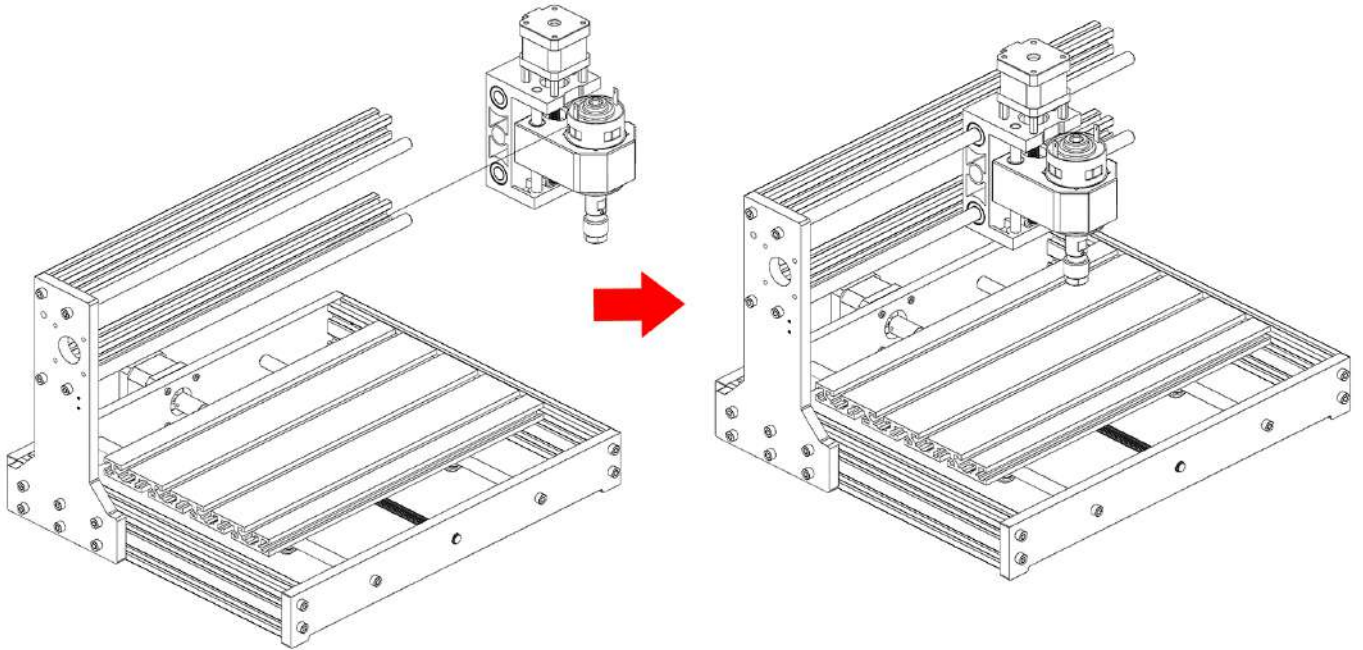

6. Installation of the right-side plate/右侧板的安装

Use/使用: Right-side plate/右侧板 1pcs

M5*16 4pcs

M5*25 6pcs

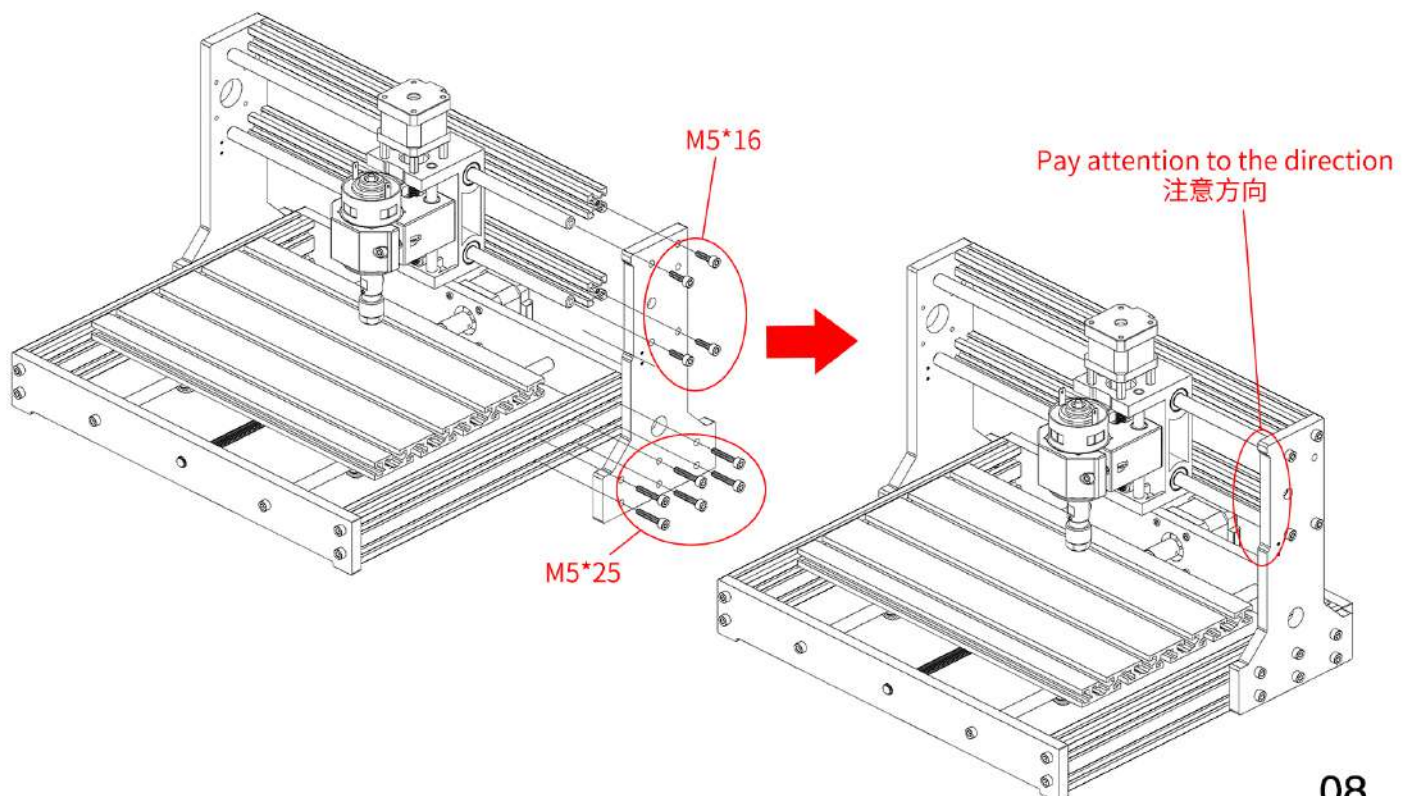

7. Installation of X-axis screw motor/X轴丝杆电机的安装

7.1. Installation of X-axis T8 screw/X轴T8丝杆安装

Align the screw with the copper nut of the Z-axis module, and turn it clockwise to the screw bearing installation hole on the right side plate.

将丝杆对准Z轴模组的铜螺母，顺时针旋转至右侧板丝杆轴承安装孔位出

Use/使用: T8-4*360 Screw/丝杆 1pcs
Brass nut/黄铜螺母 1pcs
Spring/弹簧 1pcs

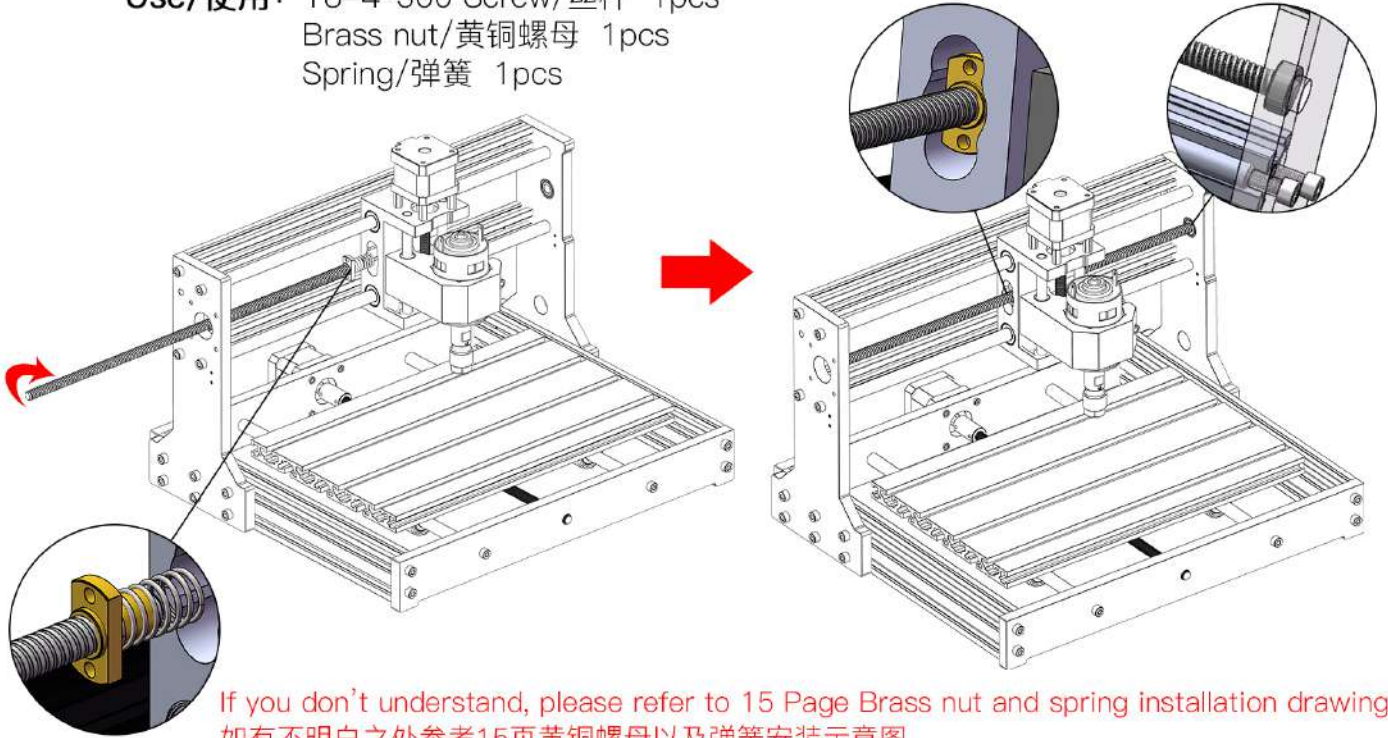

If you don't understand, please refer to 15 Page Brass nut and spring installation drawing
如有不明白之处参考15页黄铜螺母以及弹簧安装示意图

7.2. Installation of X-axis motor/X轴电机的安装

Use/使用: 42 step motor components/42步进电机组件 1pcs
M3*14 4pcs

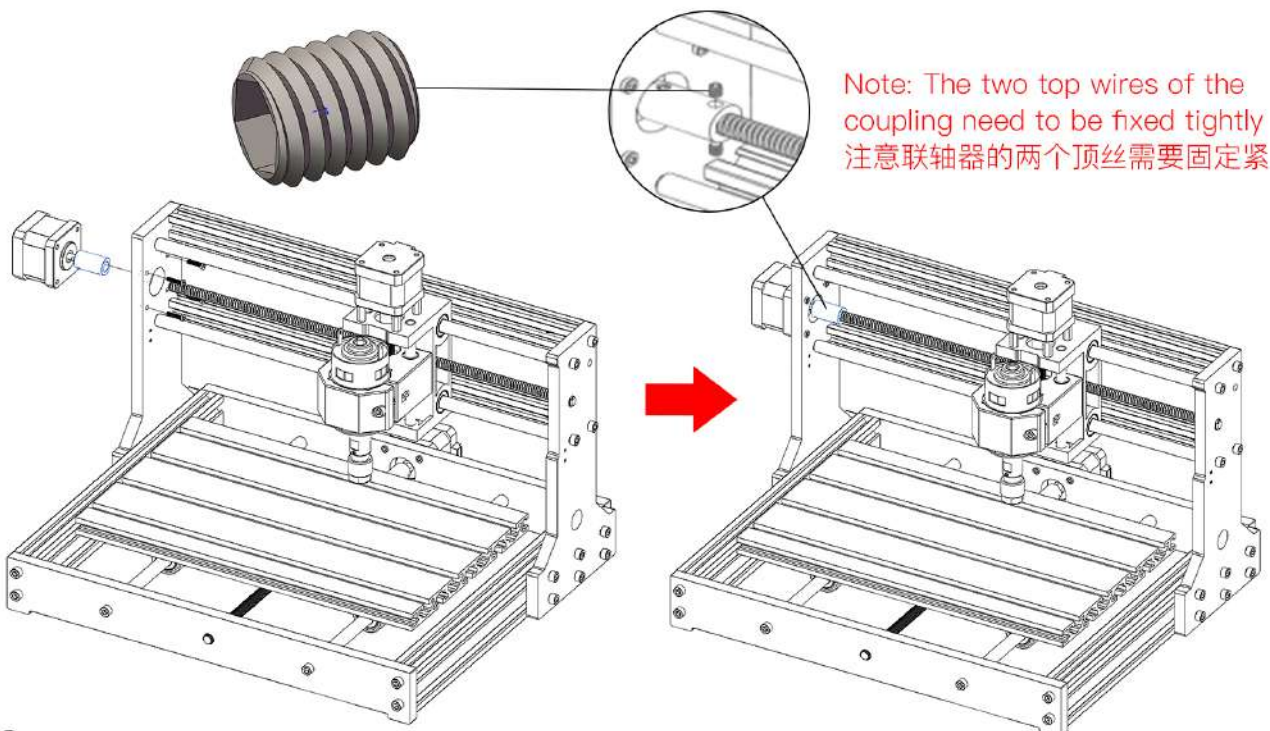

Note: The two top wires of the coupling need to be fixed tightly
注意联轴器的两个顶丝需要固定紧

8. Instruction of Mainboard Wiring/主板的安装

Use/使用: Motherboard module/主板套件 1pcs

M4*12 4pcs

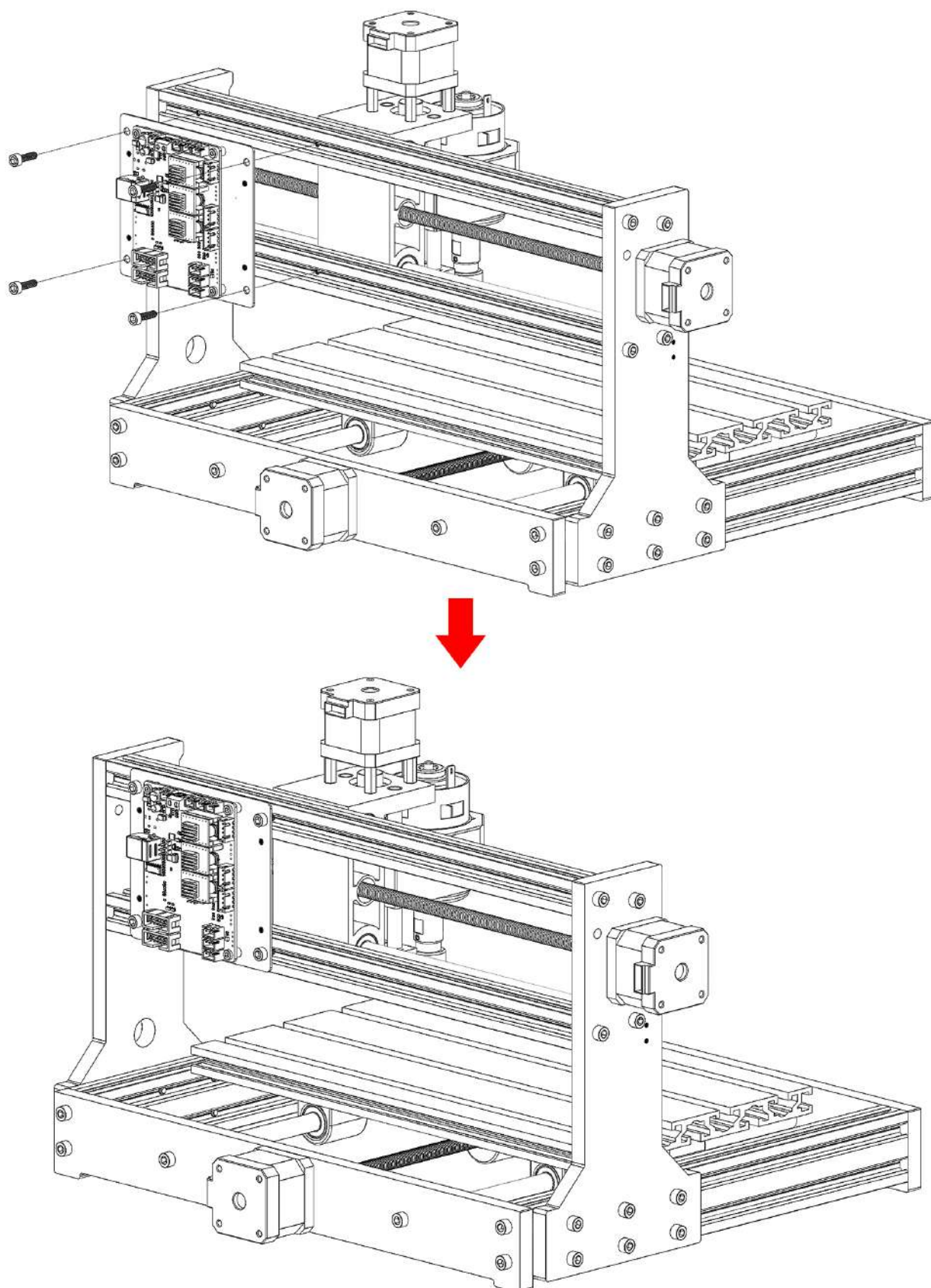

MOTHERBOARD DESCRIPTION/主板说明

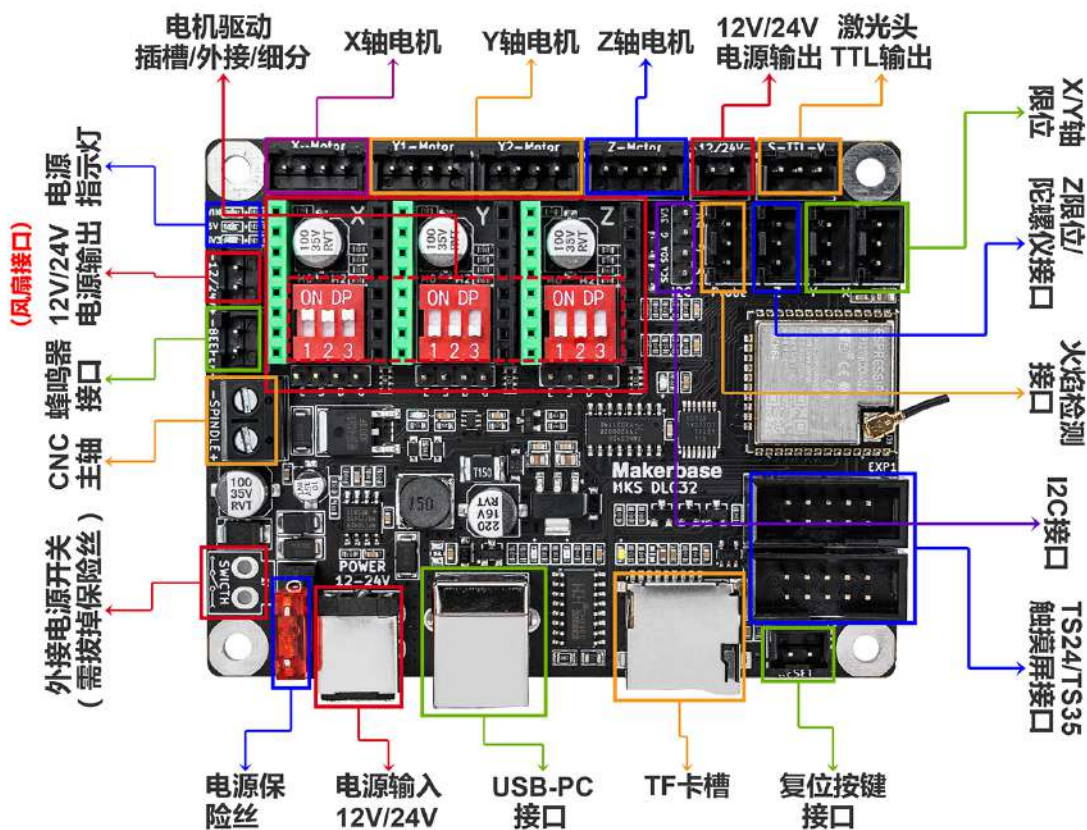
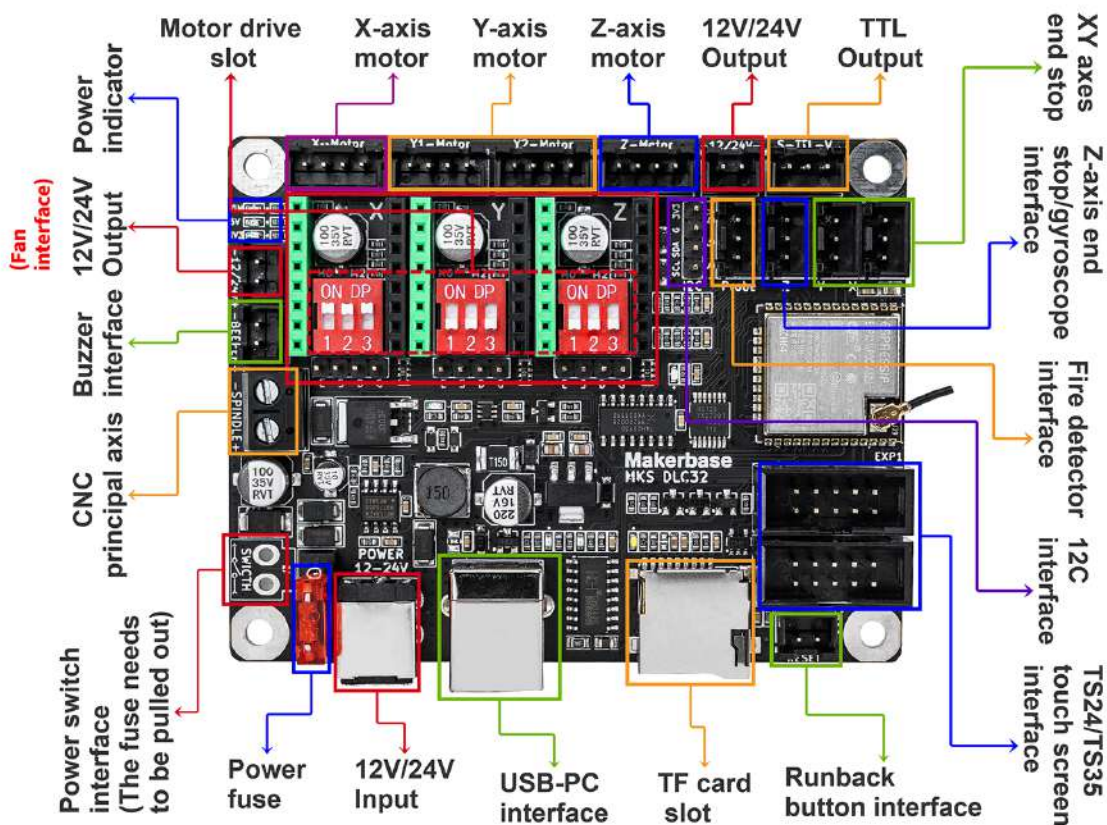

INSTRUCTION OF MAINBOARD WIRING/主板接线说明

9. Wiring of Mainboard/主板接线

Note: The red or "+" mark on the spindle motor is positive, and the other end is negative.(For details, see the main diagram motor wiring diagram)

注意：主轴电机上的红色或“+”标记为正极，另一端为负极。(详情见主图电机接线图)

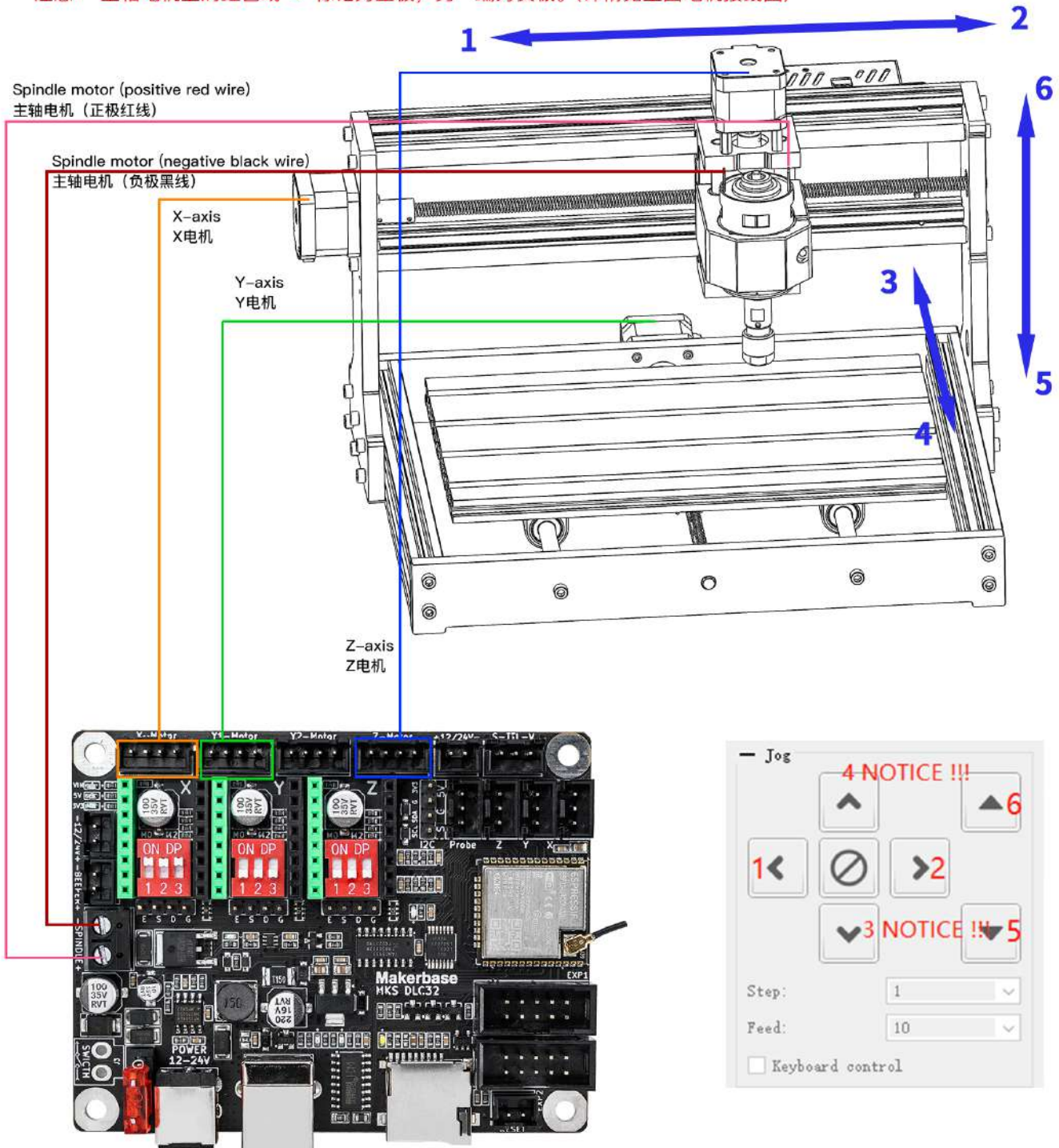

If you click the button,The machine is not moving in the corresponding numerical direction,that means the stepper motor in this direction is reversed . Please exchange the motor wire on the control board.

如果单击该按钮，则机器未在相应的数字方向上移动，这意味着步进电机在该方向上反转。请更换控制板上的电机线。

10. Special instructions for spindle motor wiring: 主轴电机接线特别说明:

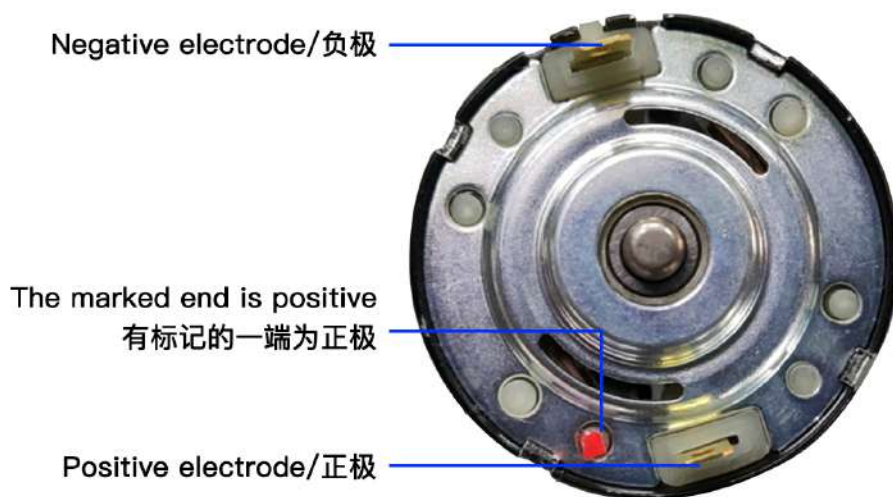

How to install and use Candle? Please scan the QR code to download the instruction.

Candle安装教程和操作教程, 请扫描二维码下载

11. Mainboard Cover Installation/主板外罩安装

Use/使用: Cover/主板外罩 1pcs

M3*6 4pcs

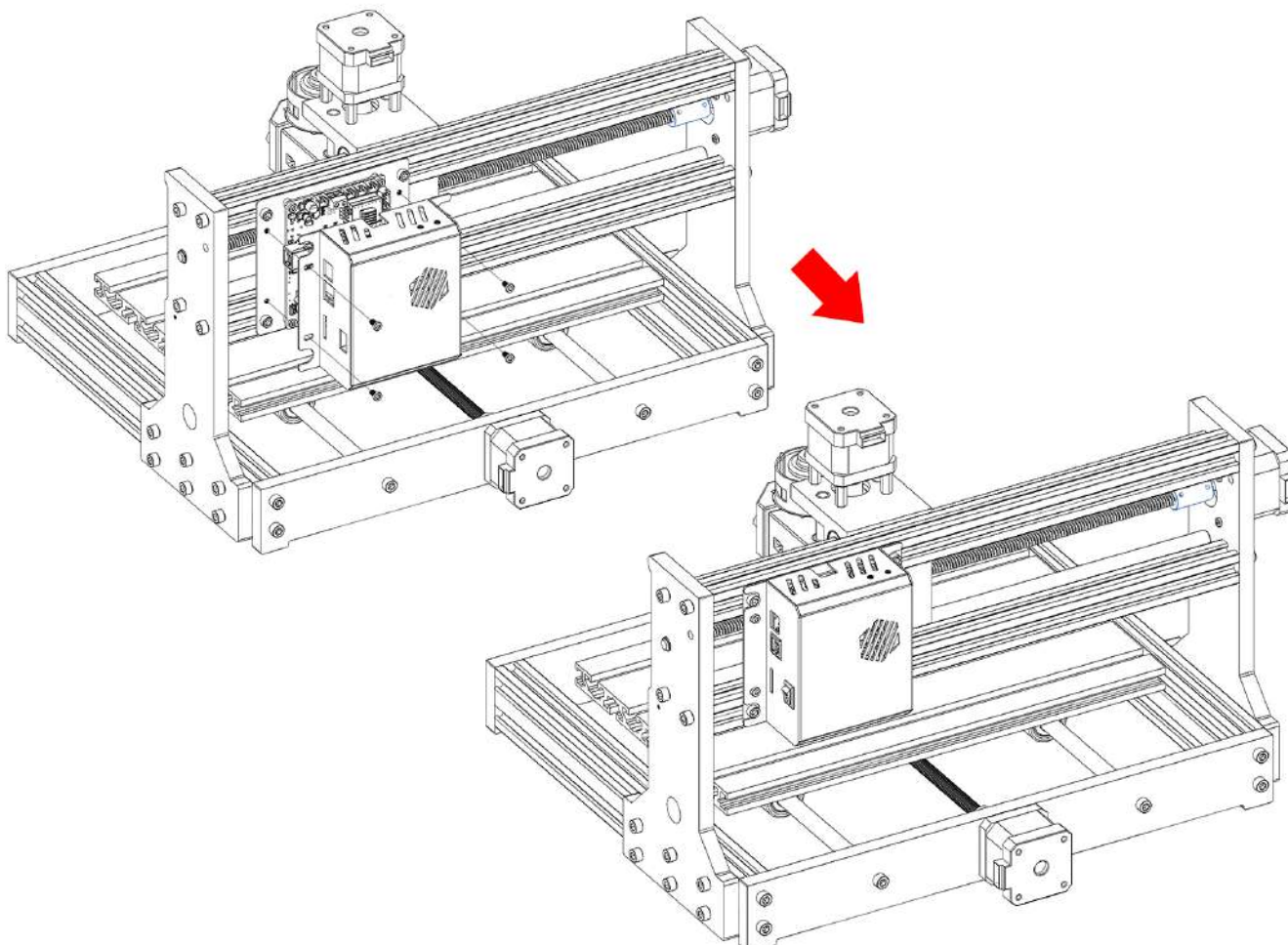

INSTALLATION OF MILLING CUTTER/铣刀的安装

12. How to install the milling cutter/铣刀的安装方法

Use/使用: Milling cutter/铣刀 1PCS

ER11 chuck/ER11夹头 1PCS

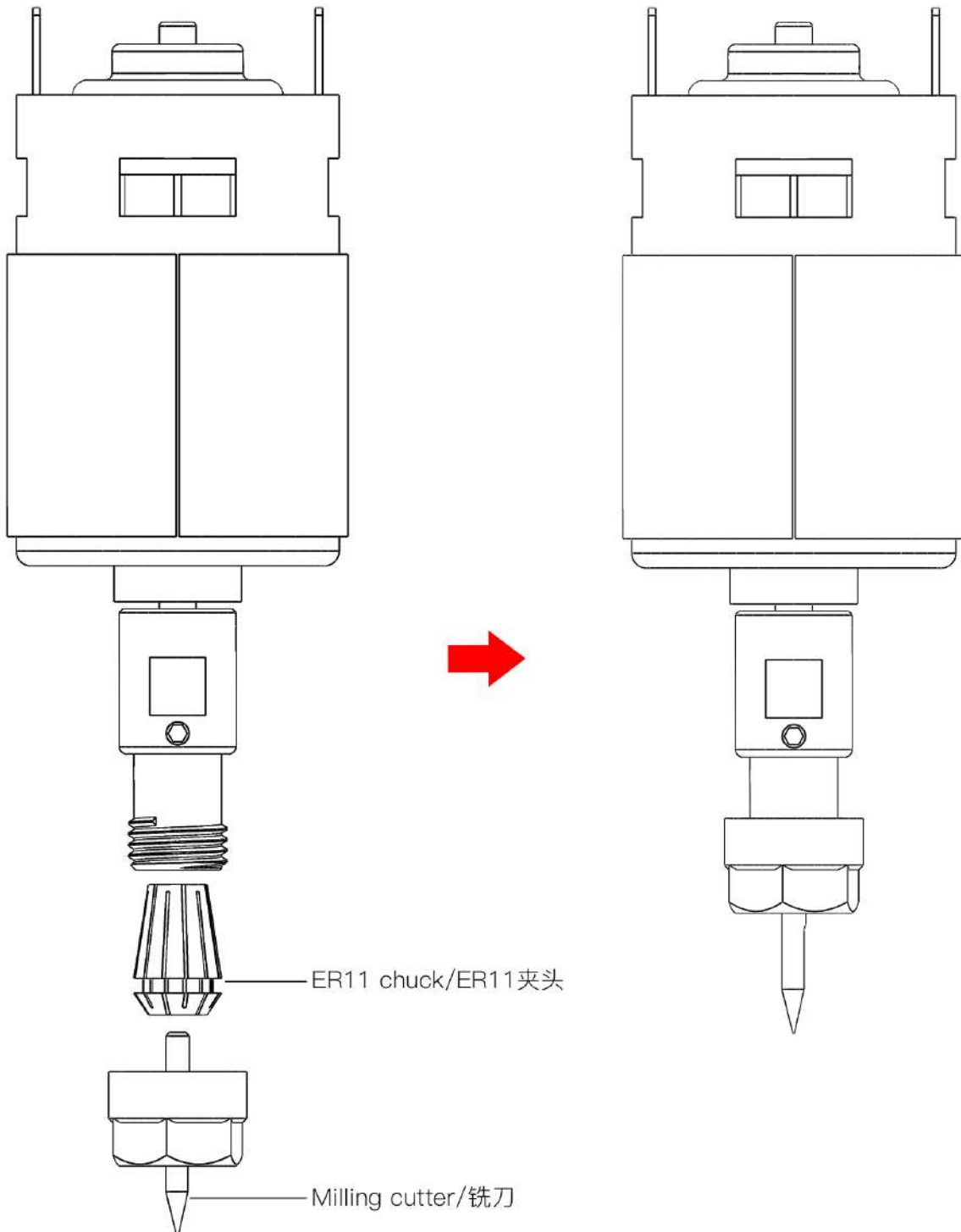

Note: that the clamping length of the milling cutter is about 1/2 of the total length of the milling cutter
注意: 铣刀夹紧长度大概为铣刀总长的1/2

CLAMPING SCREW INSTALLATION/夹紧螺丝安装

14. Clamping screw installation renderings/装夹螺丝安装效果图

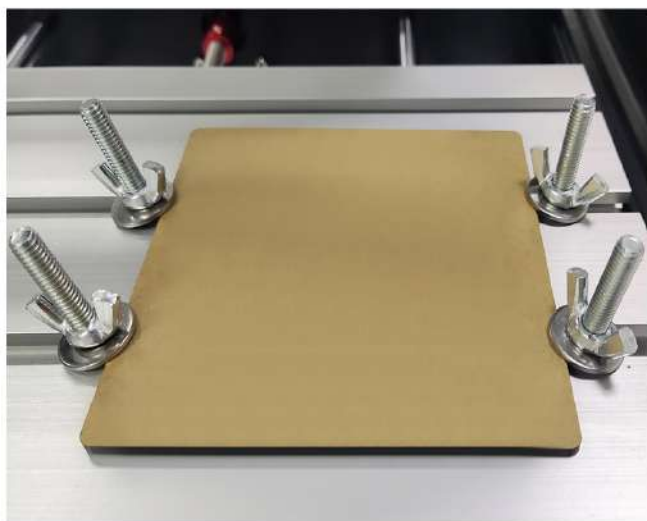

15. Schematic diagram of XY axis screw brass nut and spring installation reference/XY轴丝杆黄铜螺母及弹簧安装参考示意图

When screwing the brass nut into the screw, it must be flush with the screw, and then screw the compression spring into the screw, otherwise the brass nut cannot be installed
将黄铜螺母旋入丝杆时，必须与螺钉齐平，然后将压缩弹簧旋入丝杆，否则黄铜螺母无法安装

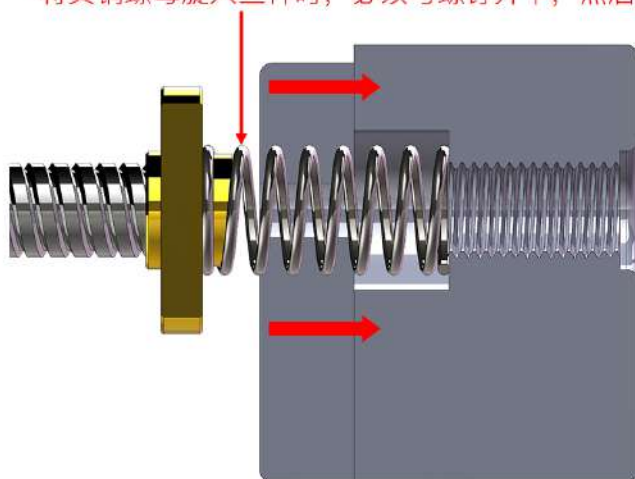

Before spring compression/弹簧压缩前

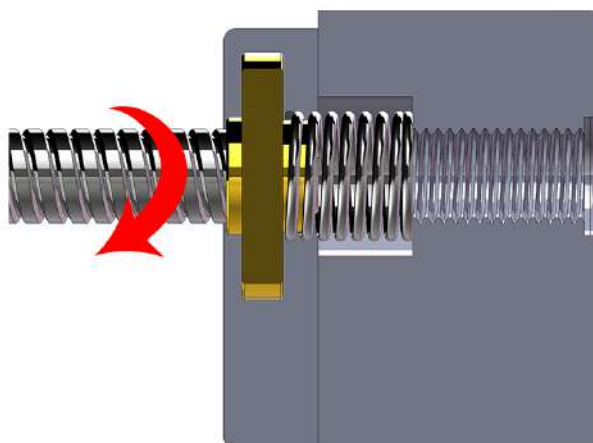

After the spring is compressed/弹簧压缩后

Note: The spring needs to be compressed before screwing in the screw
注意：需要将弹簧压缩后再旋进丝杆。

OPERATION GUIDE

操作指南

1. Debugging/调试

Install CH340 drive Program.

安装CH340驱动器程序。

Double-click CH340SER --Click Installation-- Wait for the

双击CH340SER-单击安装-等待

installation program to end.

安装程序结束。

(This drive program Supports XP32/64WIN7 32/64)

(此驱动器程序支持XP32 / 64WIN7 32/64)



Right-click My Computer--Management--Equipment manager--Port,

check whether there is CH340 Port number.

右键单击“我的电脑”-“设备管理器”-“端口”，检查是否有“CH340”端口号。

If installation success will appear COMx, remember the number after COM

如果安装成功将出现COMx，请记住COM后面的数字



Use Candle(Control Software) to connect machine:

使用Candle（控制软件）连接机器：



Candle

Open Control Software Candle. This software is for control CNC 3 Axis carving. First of all set port number, and then return to the main interface of software,software will connection machine automatically.

开放式控制软件Candle。该软件用于控制CNC 3轴雕刻。首先设置端口号，然后返回软件主界面，软件将自动连接机器。

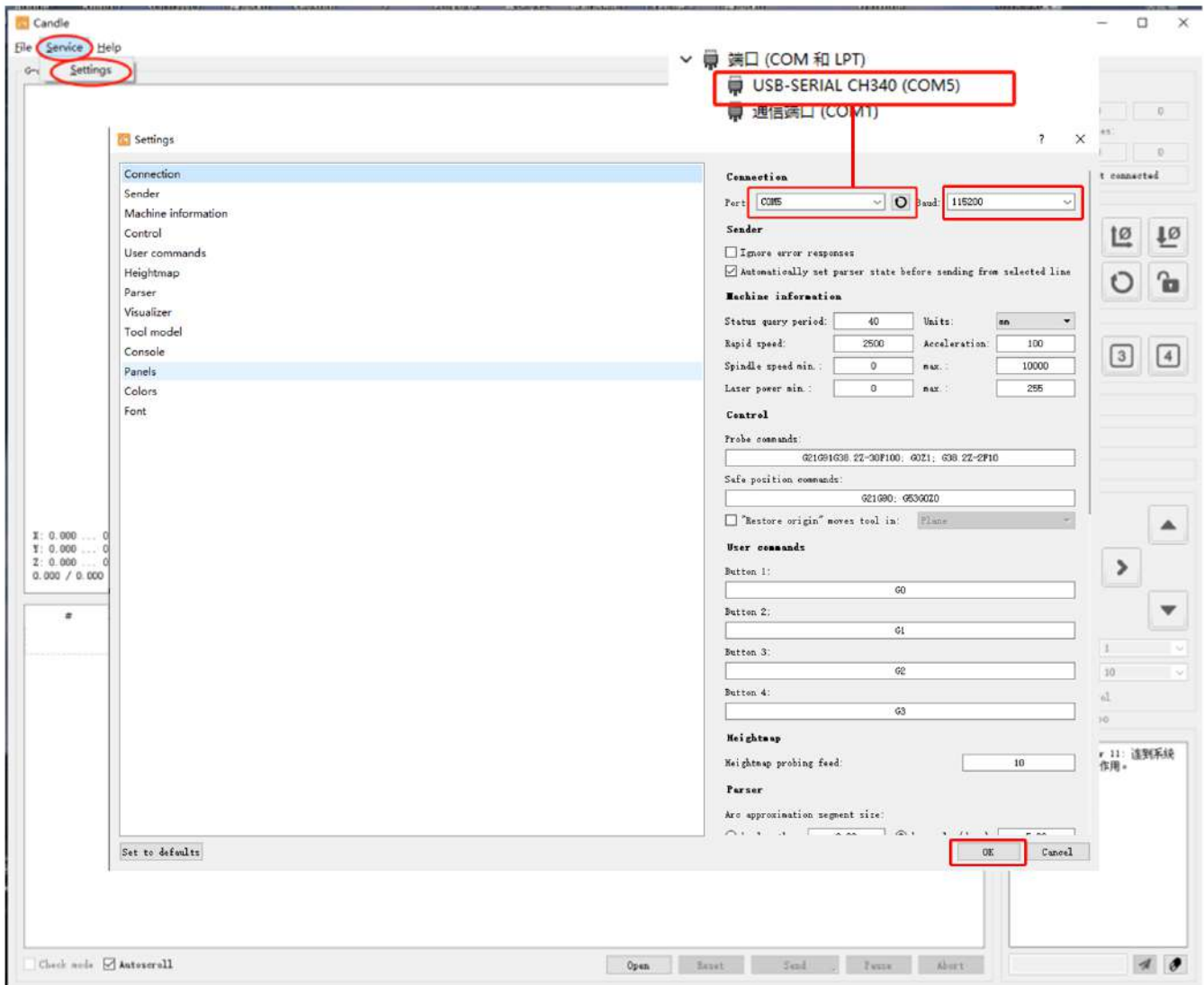

The port number must be the same as last step, otherwise software can not connect the machine. 端口号必须与上一步相同，否则软件将无法连接机器。

If connect machine successfully the main interface will display: [CTRL+X] < Grbl 0.9j ['\$' for help]. If no this display or display other information it means connection failure. Please check whether you have followed all the steps. Or close software, pull out USB wire. And connect USB wire–open software–set port number–connect machine again

如果成功连接机器，则主界面将显示：[CTRL+X] < Grbl 0.9j ['\$' for help]。如果不显示或不显示其他信息，则表明连接失败。请检查您是否已按照所有步骤操作。或关闭软件，拔出USB线。并再次连接USB有线软件设置的端口号–连接机器

Candle main interface introduction:

Candle主界面介绍:

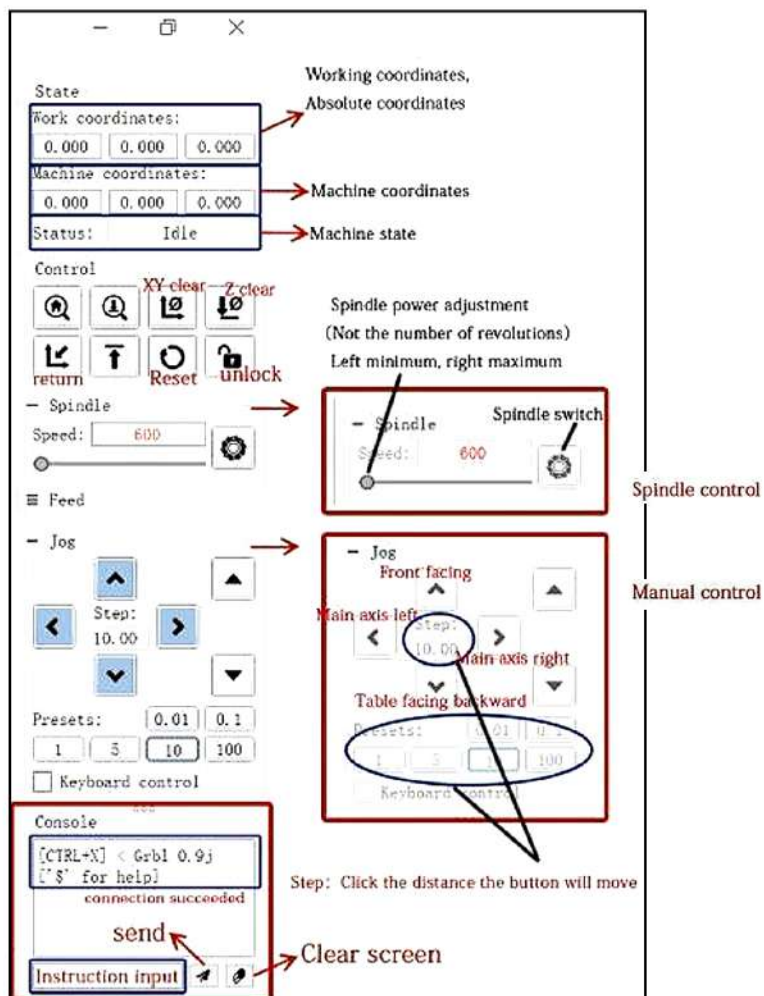
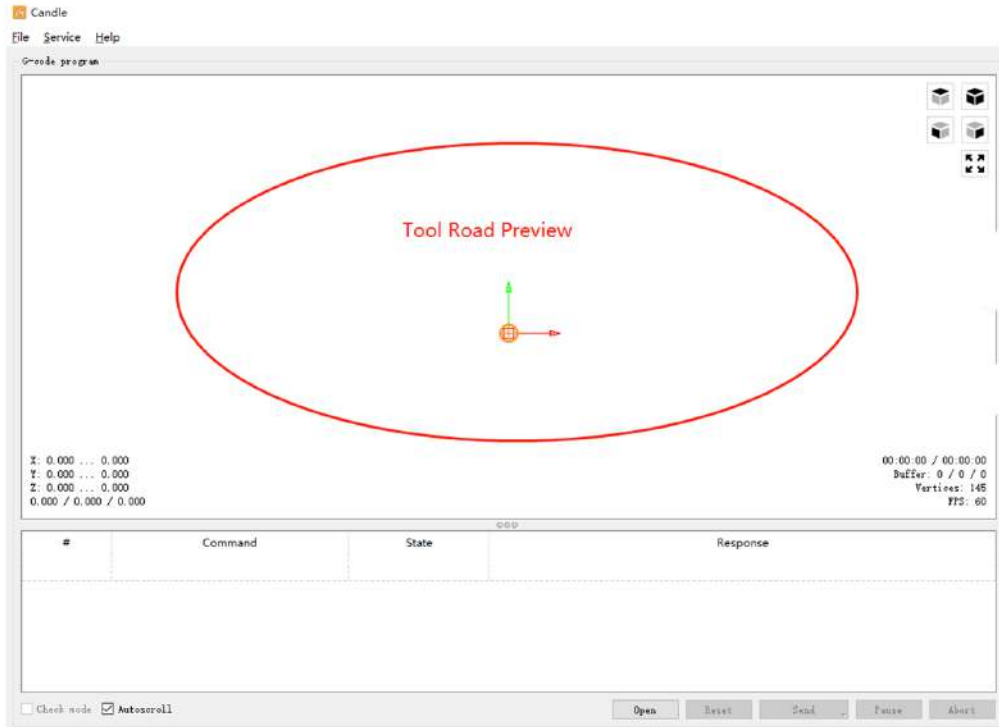

Direction check: check whether the machine moves the same direction when you click on the software
 方向检查: 单击软件时检查机器是否向同一方向移动

2. After direction checking we can start to work.

经过方向检查，我们可以开始工作。

Cutter setting: to set the position where we start to work. Move cutter to the position, click xy and z axis coordinate zero clearing, then it will start to engrave at this point.

切刀设置：设置我们开始工作的位置。将刀具移至该位置，单击xy和z轴坐标清零，然后将在此处开始雕刻。

When you do last step please make the spindle running because the cutter may touch the object you want to engrave

当您执行最后一步时，请使主轴运行，因为刀具可能会碰到您想要雕刻的物体

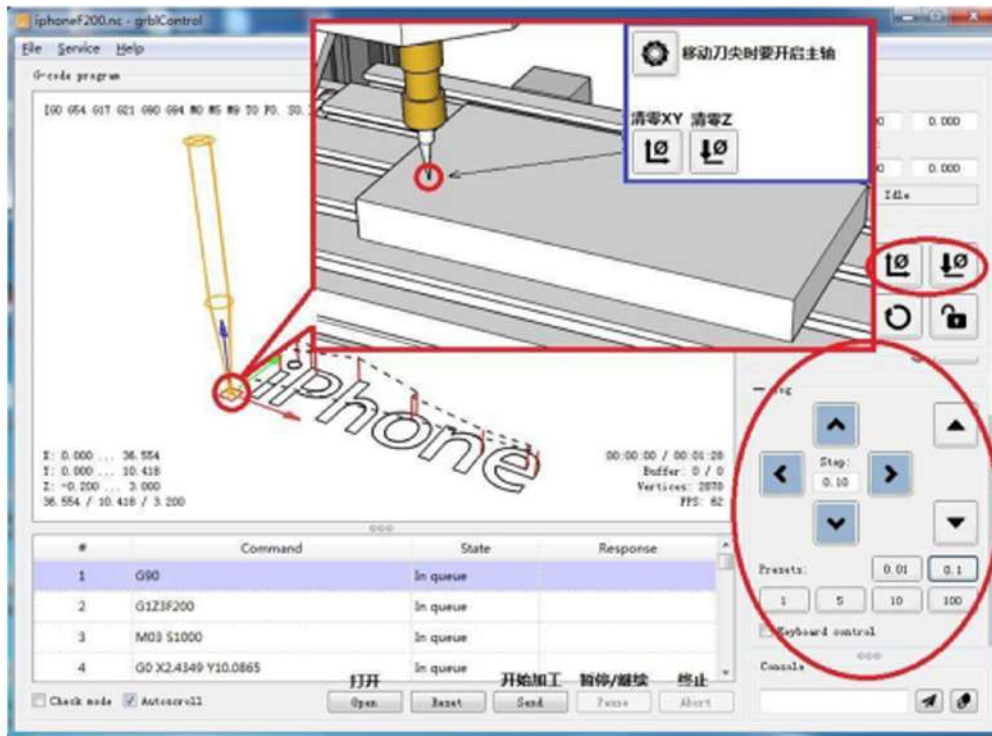

After first testing, then you can try to make your own gcode for engraving.

经过首次测试后，您可以尝试制作自己的gcode进行雕刻。

Gcode is the command that make the machine move. It should be a .nc file. In the folder there are some .nc files. You can check.

Gcode是使机器移动的命令。它应该是一个.nc文件。该文件夹中有一些.nc文件。您可以检查。

Matched software to make .nc file is ARTCAM(In the link it is old version, if you want to get latest version you can search it on internet, it is very common software):

用于制作.nc文件的配套软件是ARTCAM（在链接中为旧版本，如果要获取最新版本，则可以在互联网上搜索它，这是非常常见的软件）：

<https://www.dropbox.com/s/n1pi86z2lu5zd8q/ArtCAM.rar?dl=0>

This is one version, you can also get some other latest version on internet.

这是一个版本，您也可以在互联网上获得其他一些最新版本。

AFTER-SALES SERVICE/售后服务

The guarantee period is 12 months from the date of purchase.

1. Missing/Damaged/Defective Parts

Within 7 days of the date of receipt, we will replace any parts for free of charge including shipping fees.

After 7 days of the date of receipt, we will replace any parts for free of charge. But you need to pay the shipping fees.

2. Customer Damaged Parts: You need to pay for the cost of the parts and the shipping fees.

3. Courier company loss, missing, damaged, and defective parts.

a. Lost or damaged shipments must be reported to the carrier within the carrier's claim window, and you need to inform us within 7 days of the date of receipt.

b. For any parts lost or damaged during shipping, you need to take photos or video and send them to us.

c. Once the Carrier dispute is settled, please provide us with all communications with the carrier. It is the customer's responsibility to keep us up to date with ALL communication with the carrier.

d. For Missing Parts, you need to fill out a Service Ticket.

e. For Damaged Parts, you need to fill out a Service Ticket and send us the photos or video.

保修期为自购买之日起12个月内。

1. 缺少 / 损坏 / 有缺陷的部件：

签收日期后的7天内，我们将免费更换任何部件，包括运费；

2. 签收日期后的7天后，我们将免费更换任何部件。但客户需要支付运费。

3. 客户损坏部件：客户应支付部件成本和运输费用。

a. 对于丢失或损坏的货物的索赔必须在承运人的索赔窗口内向承运人报告，客户需要在签收日期后的7天内通知我们。

b. 对于在运输过程中丢失或损坏的任何部件，客户应拍摄照片或视频并将信息发送给我们。

c. 一旦承运人争议解决，请向我们提供与承运人的所有通讯。客户有责任让我们及时了解与承运人的所有通讯。

d. 对于缺失零件，客户应填写服务单。

§ 15.19 Labelling requirements.

This device complies with part 15 of the FCC Rules. Operation is subject to the following two conditions: (1) This device may not cause harmful interference, and (2) this device must accept any interference received, including interference that may cause undesired operation.

§ 15.21 Information to user.

Any Changes or modifications not expressly approved by the party responsible for compliance could void the user's authority to operate the equipment.

§ 15.105 Information to the user.

Note: This equipment has been tested and found to comply with the limits for a Class B digital device, pursuant to part 15 of the FCC Rules. These limits are designed to provide reasonable protection against harmful interference in a residential installation. This equipment generates uses and can radiate radio frequency energy and, if not installed and used in accordance with the instructions, may cause harmful interference to radio communications. However, there is no guarantee that interference will not occur in a particular installation. If this equipment does cause harmful interference to radio or television reception, which can be determined by turning the equipment off and on, the user is encouraged to try to correct the interference by one or more of the following measures:

- Reorient or relocate the receiving antenna.
- Increase the separation between the equipment and receiver.
- Connect the equipment into an outlet on a circuit different from that to which the receiver is connected.
- Consult the dealer or an experienced radio/TV technician for help.

This equipment complies with FCC radiation exposure limits set forth for uncontrolled environment. This equipment should be installed and operated with minimum distance 20cm between the radiator & your body.