

# 天线规格承认书

## Antenna Specification for Approval

Shenzhen Lixinhui Electronics Co., Ltd

211 Zongtai Green Kaizhi Hui Yuan, Xingdong Community,  
Xin'an Street, Bao'an District, Shenzhen

产品名称: \_

Product Name: 2.4GAntenna length 35mm

产品料号:

Part NO. : C10-35-2.5

日期:

Issued Date: 2021.9.4

样盘	揭杆	截断嘴	刃

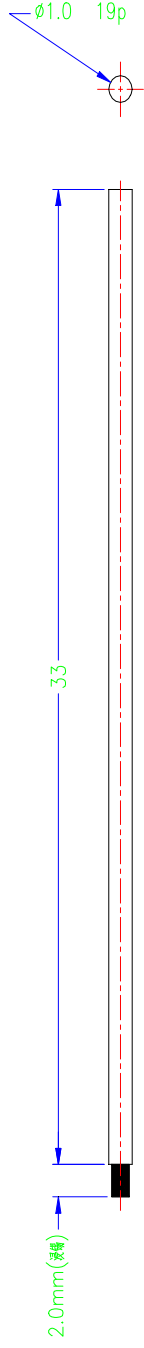

线材: 1mm白色镀线

# 利信辉电子有限公司

要求:  
1、标注公差为重要尺寸, 未标注公差的按±0.15。

PART TITLE 锚玻璃摩擦片	MATERIAL 第 1mm白色镀线	UNIT IN 英寸	SCALE 放大 5:1	VER. 吹棒 101
PART NO. 锚玻璃摩擦片 C10-33-2.0	DRW IN G 英寸	DATE 2015/12/09	CHECK IN G 机瞄	SUPPLIER CFM 鼎尚改 摩

# Product Specification

## A. Electrical Characteristics

**Frequency 2400MHz ~2500MHz**

**VSWR <3.0**

**Efficiency >30%**

**Impedance 50 Ohm**

**Polarization Line**

**Gain 0.17dBi**

## B. Material & Mechanical Characteristics

**Material of Radiator Cu**

**Cable Type 1.0 19P**

**Connector Type : NO**

**Dimension**

## C. Environmental

**Operation Temperature - 30 °C ~ + 80 °C**

**Storage Temperature - 30 °C ~ + 85 °C**

## Test Equipment & Conditions

### 1. Network Analyzers :

Agilent 8753D 5071B

### 2. Communications Test Set:

Agilent E5515C

### 3. 3D Chamber Test System

# Efficiency & Gain

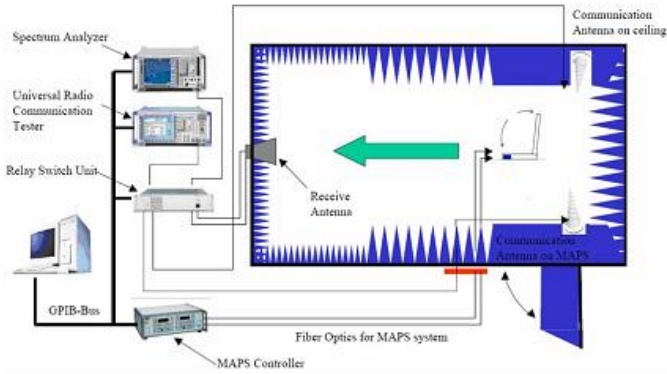

(Testing by 3D anechoic chamber)

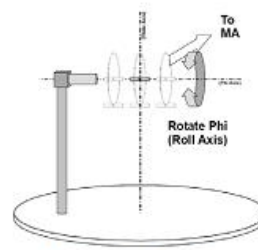

Phi axis test

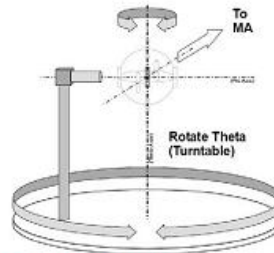

Theta axis test

# Efficiency & Gain

2.40	-2.17
2.440	0.12
2.48	0.17

# Radiation Pattern:

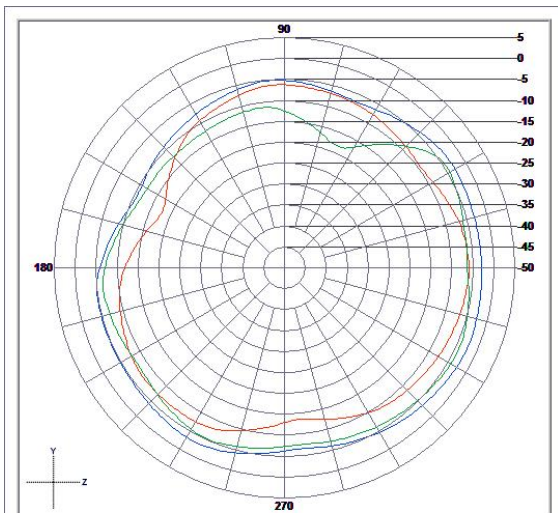

	Vertical	Horizontal	Total
Avg. Gain	-8.4	-6.99	-4.63
Peak Gain	-5.48	-3.77	-2.17

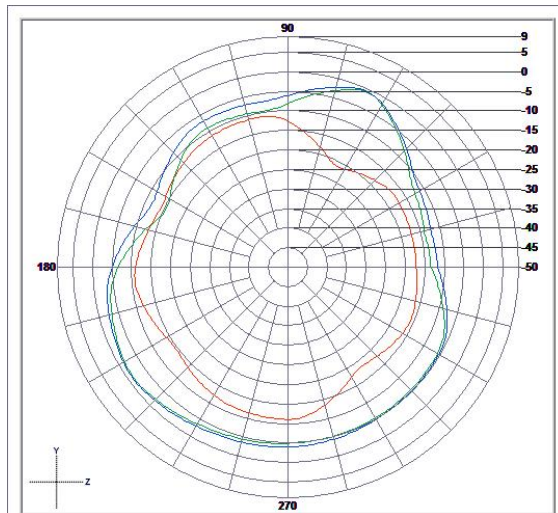

	Vertical	Horizontal	Total
Avg. Gain	-13.34	-5.06	-4.46
Peak Gain	-10.3	0.09	0.12

