

FCC Test Report

FCC ID: 2A7DX-TAB30WIFI

Product: Tablet PC

Trade Mark: Blackview, OSCAL

Model Number: Tab 30 WIFI

Family Model: Tab 30 Kids, Pad 50 WIFI, Pad 50 Kids

Report No.: S24040306105006

Issue Date: Apr 17, 2024

Prepared for

DOKE COMMUNICATION (HK) LIMITED
19H MAXGRAND PLAZANO 3 TAI YAU STREETSAN PO KONGKL

Prepared by

Shenzhen NTEK Testing Technology Co., Ltd.
1/F, Building E, Fenda Science Park, Sanwei Community,
Xixiang Street Bao'an District, Shenzhen P.R. China
Tel. 400-800-6106, 0755-2320 0050, 0755-2320 0090
Website:<http://www.ntek.org.cn>

TEST RESULT CERTIFICATION

Applicant's name..... : DOKE COMMUNICATION (HK) LIMITED
Address : 19H MAXGRAND PLAZANO 3 TAI YAU STREETSAN PO KONGKL
Manufacturer's Name..... : Shenzhen DOKE Electronic Co., Ltd
Address : 801, Building3, 7th Industrial Zone, Yulv Community, Yutang Road, Guangming District, Shenzhen, China.

Product description

Product name..... : Tablet PC
Trade Mark..... : Blackview, OSCAL
Model and/or type reference : Tab 30 WIFI
Family Model..... : Tab 30 Kids, Pad 50 WIFI, Pad 50 Kids

Test Sample Number : S231213045006
S240403061005
Date of Test..... : Dec 13, 2023 ~ Jan 10, 2024
Apr 08, 2024 ~ Apr 16, 2024

Standards..... : FCC Part15B
ANSI C63.4:2014

This device described above has been tested by NTEK, and the test results show that the equipment under test (EUT) is in compliance with Part 15 of FCC Rules. And it is applicable only to the tested sample identified in the report.

This report shall not be reproduced except in full, without the written approval of NTEK, this document may be altered or revised by NTEK, personnel only, and shall be noted in the revision of the document.

Note: All test data of this report are based on the original test report S23121304505005, dated by Jan 10, 2024

Prepared By: Allen Liu (Project Engineer)

Reviewed By: Aaron Cheng (Supervisor)

Approved By: Alex Li (Manager)

Table of Contents

Page

1 . TEST SUMMARY	5
1.1 TEST FACILITY	6
1.2 MEASUREMENT UNCERTAINTY	6
2 . GENERAL INFORMATION	7
2.1 GENERAL DESCRIPTION OF EUT	7
2.2 DESCRIPTION OF TEST SETUP	9
2.3 DESCRIPTION TEST PERIPHERAL AND EUT PERIPHERAL	10
2.4 MEASUREMENT INSTRUMENTS LIST	11
3 . EMC EMISSION TEST	12
3.1 CONDUCTED EMISSION MEASUREMENT	12
3.1.1 POWER LINE CONDUCTED EMISSION	12
3.1.2 TEST PROCEDURE	13
3.1.3 TEST SETUP	13
3.1.4 EUT OPERATING CONDITIONS	13
3.1.5 TEST RESULTS	14
3.2 RADIATED EMISSION MEASUREMENT	18
3.2.1 LIMITS OF RADIATED EMISSION MEASUREMENT	18
3.2.2 TEST PROCEDURE	18
3.2.3 TEST SETUP	19
3.2.4 TEST RESULTS	20
3.2.5 TEST RESULTS(1000~18000MHz)	24

1. TEST SUMMARY

Test procedures according to the technical standards:

EMC Emission				
Standard	Test Item	Limit	Judgment	Remark
FCC Part15B ANSI C63.4: 2014	Conducted Emission	Class B	PASS	
	Radiated Emission	Class B	PASS	

NOTE:

- (1) 'N/A' denotes test is not applicable in this Test Report
- (2) For client's request and manual description, the test will not be executed.

1.1 TEST FACILITY

Shenzhen NTEK Testing Technology Co., Ltd
 Add. : 1/F, Building E, Fenda Science Park, Sanwei Community, Xixiang Street, Bao'an District, Shenzhen 518126 P.R. China.

IC-Registration The Certificate Registration Number is 9270A.
 CAB identifier:CN0074

FCC- Accredited Test Firm Registration Number: 463705.
 Designation Number: CN1184

1.2 MEASUREMENT UNCERTAINTY

The reported uncertainty of measurement $y \pm U$, where expanded uncertainty U is based on a standard uncertainty multiplied by a coverage factor of $k=2$, providing a level of confidence of approximately **95** %.

A. Conducted Measurement :

Test Site	Method	Measurement Frequency Range	U, (dB)	NOTE
NTEKC01	ANSI	150 KHz ~ 30MHz	±2.80dB	

B. Radiated Measurement :

Test Site	Method	Measurement Frequency Range	U, (dB)	NOTE
NTEKA01	ANSI	30MHz~1000MHz	±2.64dB	
		1GHz~6GHz	±2.40dB	
		6GHz~26.5GHz	±2.52dB	

2. GENERAL INFORMATION

2.1 GENERAL DESCRIPTION OF EUT

Equipment	Tablet PC					
Trade Mark	Blackview, OSCAL					
Model Name	Tab 30 WIFI					
Family Model	Tab 30 Kids, Pad 50 WIFI, Pad 50 Kids					
Model Difference	All the model are the same circuit and RF module, the difference is in appearance, trade mark and camera position structure.					
Product Description	<table border="1"> <tr> <td>Connecting I/O port:</td> <td>Micro USB, Earphone</td> </tr> <tr> <td>Operation Frequency:</td> <td>5.8GHz</td> </tr> </table>		Connecting I/O port:	Micro USB, Earphone	Operation Frequency:	5.8GHz
	Connecting I/O port:	Micro USB, Earphone				
	Operation Frequency:	5.8GHz				
Based on the application, features, or specification exhibited in User's Manual, the EUT is considered as an ITE/Computing Device. More details of EUT technical specification, please refer to the User's Manual.						
Adapter	Model: QZ-01004AA00 Input:100-240V~50/60Hz 0.3A Output:5.0V $\overline{\text{---}}$ 2.0A (10.0W)					
Battery	Battery 1: DC 3.8V, 5100mAh, 19.38Wh Model: FHPK26106133P Battery 2: DC 3.8V, 5100mAh, 19.38Wh Model: Li2753130HTT					
Power supply	DC 3.8V from battery or DC 5V from adapter					
Hardware version:	BND-A863-D V1.1					
Software version:	Pad_50_WiFi_EEA_A863-D_V1.1					

2.1.1 DESCRIPTION OF TEST MODES

To investigate the maximum EMI emission characteristics generates from EUT, the test system was pre-scanning tested base on the consideration of following EUT operation mode or test configuration mode which possible have effect on EMI emission level. Each of these EUT operation mode(s) or test configuration mode(s) mentioned above was evaluated respectively.

Pretest Mode	Description
Model 1	USB Data Transmission
Model 2	TF card Playing
Model 3	REC
Model 4	FM
Model 5	GPS

For Conducted Test	
Final Test Mode	Description
Model 1	USB Data Transmission
Model 2	TF card Playing
Model 3	REC
Model 4	FM

For Radiated Test	
Final Test Mode	Description
Model 1	USB Data Transmission
Model 2	TF card Playing
Model 3	REC
Model 4	FM

Note: Final Test Mode: Through Pre-scan, find the model 1 is the worst case. Only the worst case mode is recorded in the report.

2.2 DESCRIPTION OF TEST SETUP

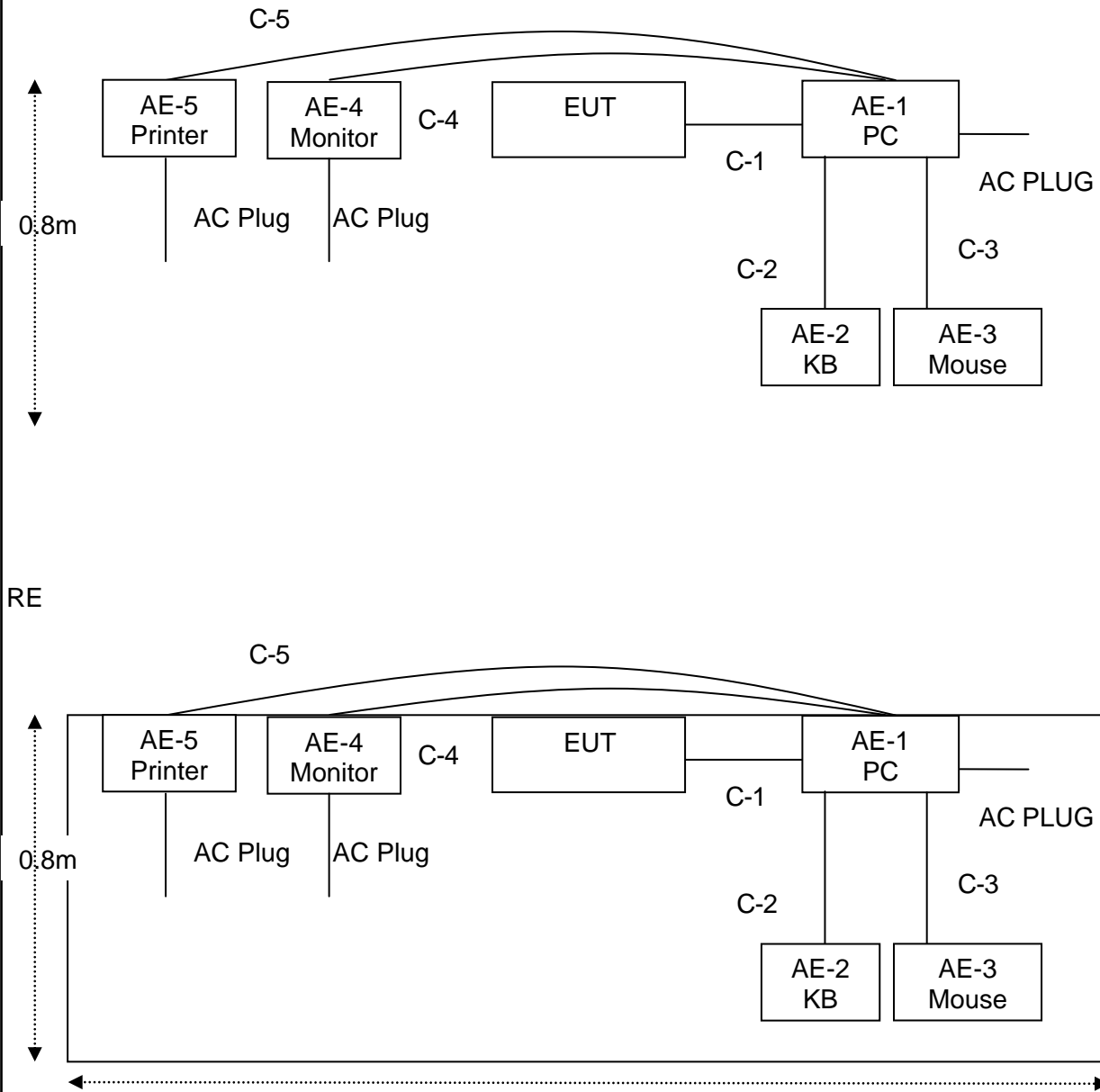

2.3 DESCRIPTION TEST PERIPHERAL AND EUT PERIPHERAL

The EUT has been tested as an independent unit together with other necessary accessories or support units. The following support units or accessories were used to form a representative test configuration during the tests.

Item	Equipment	Brand	Model/Type No.	Series No.	Note
AE-1	PC	DELL	FT4Y23X	N/A	Peripherals
AE-2	KB	N/A	N/A	N/A	Peripherals
AE-3	Mouse	DELL	MS111-P	N/A	Peripherals
AE-4	Monitor	DELL	IN2020MB	N/A	Peripherals
AE-5	Printer	Canon	L11121E	N/A	Peripherals

Item	Cable Type	Shielded Type	Ferrite Core	Length	Note
C-1	USB Cable	YES	NO	1.0m	
C-2	USB Cable	NO	NO	1.2m	
C-3	USB Cable	NO	NO	1.2m	
C-4	HDMI Cable	YES	YES	1.0m	
C-5	USB Cable	NO	NO	1.2m	

Note:

- (1) The support equipment was authorized by Declaration of Confirmation.
- (2) For detachable type I/O cable should be specified the length in cm in 『Length』 column.
- (3) “YES” means “shielded” “with core”; “NO” means “unshielded” “without core”.

2.4 MEASUREMENT INSTRUMENTS LIST

Radiation Test equipment

Item	Kind of Equipment	Manufacturer	Type No.	Serial No.	Last calibration	Calibrated until	Calibration period
1	Spectrum Analyzer	Aglient	E4440A	MY41000130	2023.03.27 2024.03.12	2024.03.26 2025.03.11	1 year
2	Test Receiver	R&S	ESPI	101318	2023.03.27 2024.03.12	2024.03.26 2025.03.11	1 year
3	Bilog Antenna	TESEQ	CBL6111D	31216	2023.03.16 2024.03.11	2024.03.15 2025.03.10	1 year
4	50Ω Coaxial Switch	Anritsu	MP59B	6200264416	2023.05.06	2026.05.05	3 year
5	Spectrum Analyzer	ADVANTEST	R3132	150900201	2023.03.27 2024.03.12	2024.03.26 2025.03.11	1 year
6	Horn Antenna	SCHWARZBECK	BBHA 9120D	2816	2023.01.12	2026.01.11	3 year
7	Horn Ant	Schwarzbeck	BBHA 9170	9170-181	2022.11.07	2025.11.06	3 year
8	Amplifier	EMC	EMC051835SE	980246	2023.05.29	2024.05.28	1 year
9	Loop Antenna	ARA	PLA-1030/B	1029	2023.05.29	2024.05.28	1 year
10	Power Meter	DARE	RPR3006W	15I00041SNO84	2023.05.29	2024.05.28	1 year
11	Power Sensor	R&S	URV4-Z4	0395.1619.05	2023.05.29	2024.05.28	1 year
12	Test Cable (30MHz-1GHz)	N/A	R-02	N/A	2022.06.17	2025.06.16	3 year
13	High Test Cable(1G-40GHz)	N/A	R-03	N/A	2022.06.17	2025.06.16	3 year
14	High Test Cable(1G-40GHz)	N/A	R-04	N/A	2022.06.17	2025.06.16	3 year
15	Test Receiver	R&S	ESCI	101160	2023.03.27 2024.03.12	2024.03.26 2025.03.11	1 year

AC Conduction Test equipment

Item	Kind of Equipment	Manufacturer	Type No.	Serial No.	Last calibration	Calibrated until	Calibration period
1	Test Receiver	R&S	ESCI	101160	2023.03.27 2024.03.12	2024.03.26 2025.03.11	1 year
2	LISN	R&S	ENV216	101313	2023.03.27 2024.03.12	2024.03.26 2025.03.11	1 year
3	LISN	SCHWARZBECK	NNLK 8129	8129245	2023.03.27 2024.03.12	2024.03.26 2025.03.11	1 year
4	50Ω Coaxial Switch	ANRITSU CORP	MP59B	6200983704	2023.05.06	2026.05.05	3 year
5	Test Cable (9KHz-30MHz)	N/A	C01	N/A	2023.05.06	2026.05.05	3 year
6	Test Cable (9KHz-30MHz)	N/A	C02	N/A	2023.05.06	2026.05.05	3 year
7	Test Cable (9KHz-30MHz)	N/A	C03	N/A	2023.05.06	2026.05.05	3 year

Note: Each piece of equipment is scheduled for calibration once a year except the Test Cable which is scheduled for calibration every 3 years.

3. EMC EMISSION TEST

3.1 CONDUCTED EMISSION MEASUREMENT

3.1.1 POWER LINE CONDUCTED EMISSION (Frequency Range 150KHz-30MHz)

FREQUENCY (MHz)	Class A (dBuV)		Class B (dBuV)	
	Quasi-peak	Average	Quasi-peak	Average
0.15 -0.5	79.00	66.00	66 - 56 *	56 - 46 *
0.50 -5.0	73.00	60.00	56.00	46.00
5.0 -30.0	73.00	60.00	60.00	50.00

Note:

- (1) The tighter limit applies at the band edges.
- (2) The limit of " * " marked band means the limitation decreases linearly with the logarithm of the frequency in the range.

The following table is the setting of the receiver

Receiver Parameters	Setting
Attenuation	10 dB
Start Frequency	0.15 MHz
Stop Frequency	30 MHz
IF Bandwidth	9 kHz

3.1.2 TEST PROCEDURE

- a. The EUT was placed 0.8 meters from the horizontal ground plane with EUT being connected to the power mains through a line impedance stabilization network (LISN). All other support equipments powered from additional LISN(s). The LISN provide 50 Ohm/ 50uH of coupling impedance for the measuring instrument.
- b. Interconnecting cables that hang closer than 40 cm to the ground plane shall be folded back and forth in the center forming a bundle 30 to 40 cm long.
- c. I/O cables that are not connected to a peripheral shall be bundled in the center. The end of the cable may be terminated, if required, using the correct terminating impedance. The overall length shall not exceed 1 m.
- d. LISN at least 80 cm from nearest part of EUT chassis.
- e. For the actual test configuration, please refer to the related Item –EUT Test Photos.

3.1.3 TEST SETUP

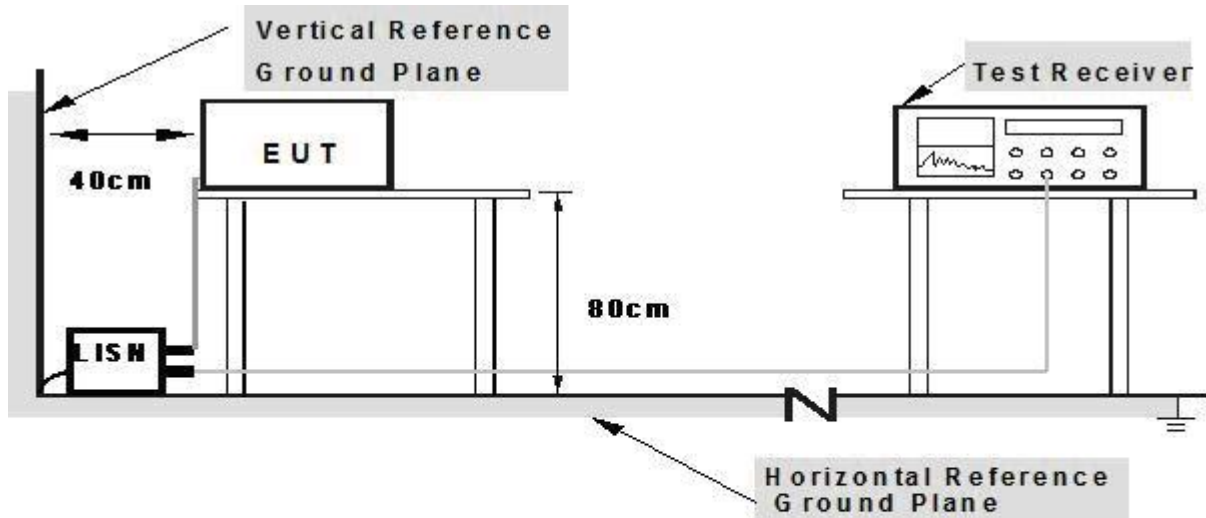

- Note: 1. Support units were connected to second LISN.**
2. Both of LISNs (AMN) are 80 cm from EUT and at least 80 cm from other units and other metal planes

3.1.4 EUT OPERATING CONDITIONS

The EUT tested system was configured as the statements of 2.3 Unless otherwise a special operating condition is specified in the follows during the testing.

3.1.5 TEST RESULTS

EUT:	Tablet PC	Model Name. :	Tab 30 WIFI
Temperature:	24.5 °C	Relative Humidity:	52%
Pressure:	1010hPa	Test Date:	2023/12/18
Test Mode:	Mode 1	Phase :	L
Test Voltage:	DC 5V from PC AC 120V/60Hz		

Frequency (MHz)	Reading Level (dBμV)	Correct Factor (dB)	Measure-ment (dBμV)	Limits (dBμV)	Margin (dB)	Remark
0.4020	29.59	10.45	40.04	57.81	-17.77	QP
0.4020	18.47	10.45	28.92	47.81	-18.89	AVG
0.6620	36.81	10.97	47.78	56.00	-8.22	QP
0.6620	27.44	10.97	38.41	46.00	-7.59	AVG
1.1420	27.67	11.94	39.61	56.00	-16.39	QP
1.1420	18.44	11.94	30.38	46.00	-15.62	AVG
2.3460	27.80	9.66	37.46	56.00	-18.54	QP
2.3460	16.45	9.66	26.11	46.00	-19.89	AVG
5.6100	26.88	9.68	36.56	60.00	-23.44	QP
5.6100	14.80	9.68	24.48	50.00	-25.52	AVG
17.0220	33.38	9.71	43.09	60.00	-16.91	QP
17.0220	17.26	9.71	26.97	50.00	-23.03	AVG

Remark:

1. All readings are Quasi-Peak and Average values.
2. Factor = Insertion Loss + Cable Loss.

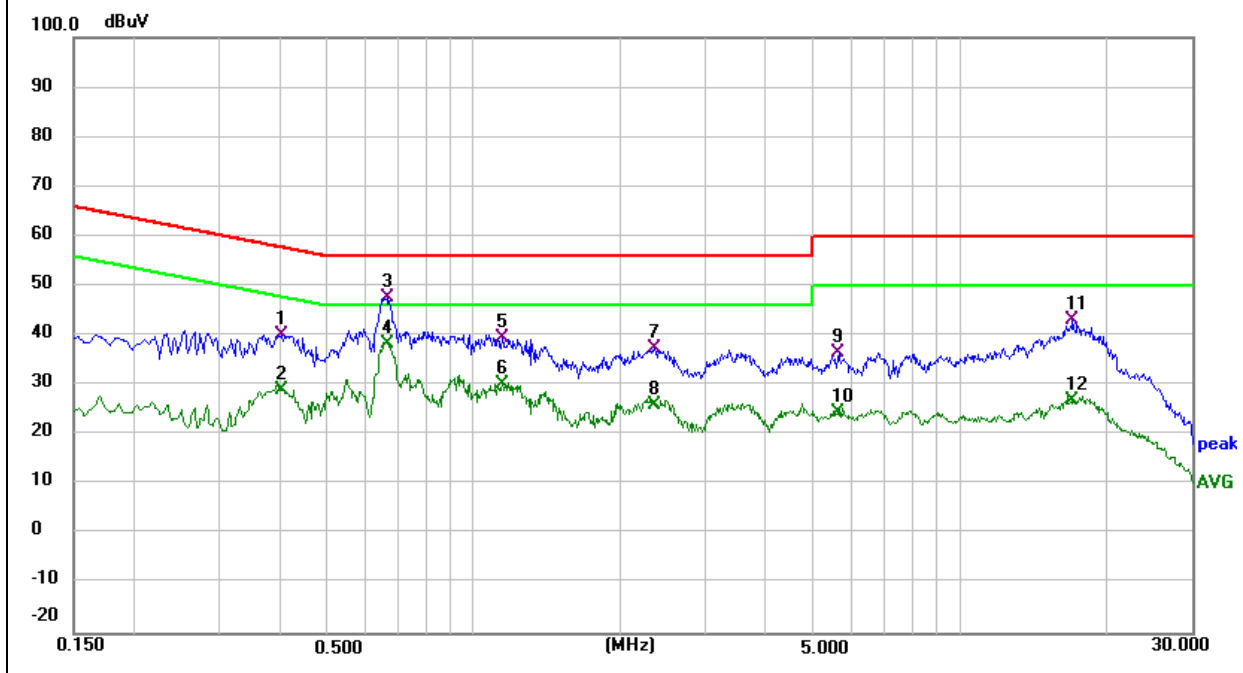

EUT:	Tablet PC	Model Name. :	Tab 30 WIFI
Temperature:	24.5 °C	Relative Humidity:	52%
Pressure:	1010hPa	Test Date:	2023/12/18
Test Mode:	Mode 1	Phase :	N
Test Voltage:	DC 5V from PC AC 120V/60Hz		

Frequency (MHz)	Reading Level (dBμV)	Correct Factor (dB)	Measurement (dBμV)	Limits (dBμV)	Margin (dB)	Remark
0.2740	28.70	10.18	38.88	61.00	-22.12	QP
0.2740	8.69	10.18	18.87	51.00	-32.13	AVG
0.6660	37.78	10.99	48.77	56.00	-7.23	QP
0.6660	16.30	10.99	27.29	46.00	-18.71	AVG
1.3099	28.59	12.28	40.87	56.00	-15.13	QP
1.3099	11.37	12.28	23.65	46.00	-22.35	AVG
2.4180	28.97	9.66	38.63	56.00	-17.37	QP
2.4180	10.03	9.66	19.69	46.00	-26.31	AVG
12.0180	25.62	9.70	35.32	60.00	-24.68	QP
12.0180	10.38	9.70	20.08	50.00	-29.92	AVG
19.4700	33.22	9.72	42.94	60.00	-17.06	QP
19.4700	13.49	9.72	23.21	50.00	-26.79	AVG

Remark:

1. All readings are Quasi-Peak and Average values.
2. Factor = Insertion Loss + Cable Loss.

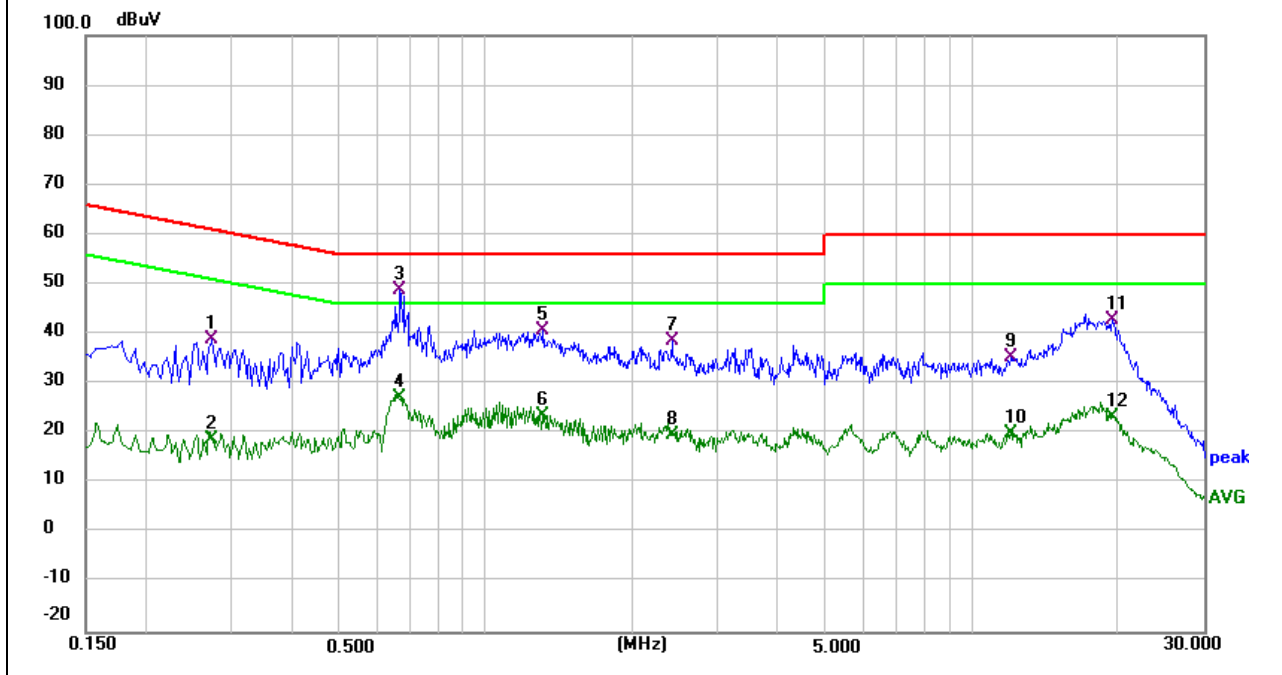

EUT:	Tablet PC	Model Name. :	Tab 30 WIFI
Temperature:	24.5 °C	Relative Humidity:	52%
Pressure:	1010hPa	Test Date:	2023/12/18
Test Mode:	Mode 1-battery 2	Phase :	L
Test Voltage:	DC 5V from PC AC 120V/60Hz		

Frequency (MHz)	Reading Level (dBμV)	Correct Factor (dB)	Measurement (dBμV)	Limits (dBμV)	Margin (dB)	Remark
0.2847	29.90	10.20	40.10	60.68	-20.58	QP
0.2847	19.82	10.20	30.02	50.68	-20.66	AVG
0.4213	29.32	10.49	39.81	57.42	-17.61	QP
0.4213	18.76	10.49	29.25	47.42	-18.17	AVG
0.6508	35.66	10.95	46.61	56.00	-9.39	QP
0.6508	25.06	10.95	36.01	46.00	-9.99	AVG
1.0710	28.45	11.80	40.25	56.00	-15.75	QP
1.0710	18.45	11.80	30.25	46.00	-15.75	AVG
2.3460	27.80	9.66	37.46	56.00	-18.54	QP
2.3460	17.89	9.66	27.55	46.00	-18.45	AVG
17.0181	32.88	9.71	42.59	60.00	-17.41	QP
17.0181	22.65	9.71	32.36	50.00	-17.64	AVG

Remark:

- All readings are Quasi-Peak and Average values.
- Factor = Insertion Loss + Cable Loss.

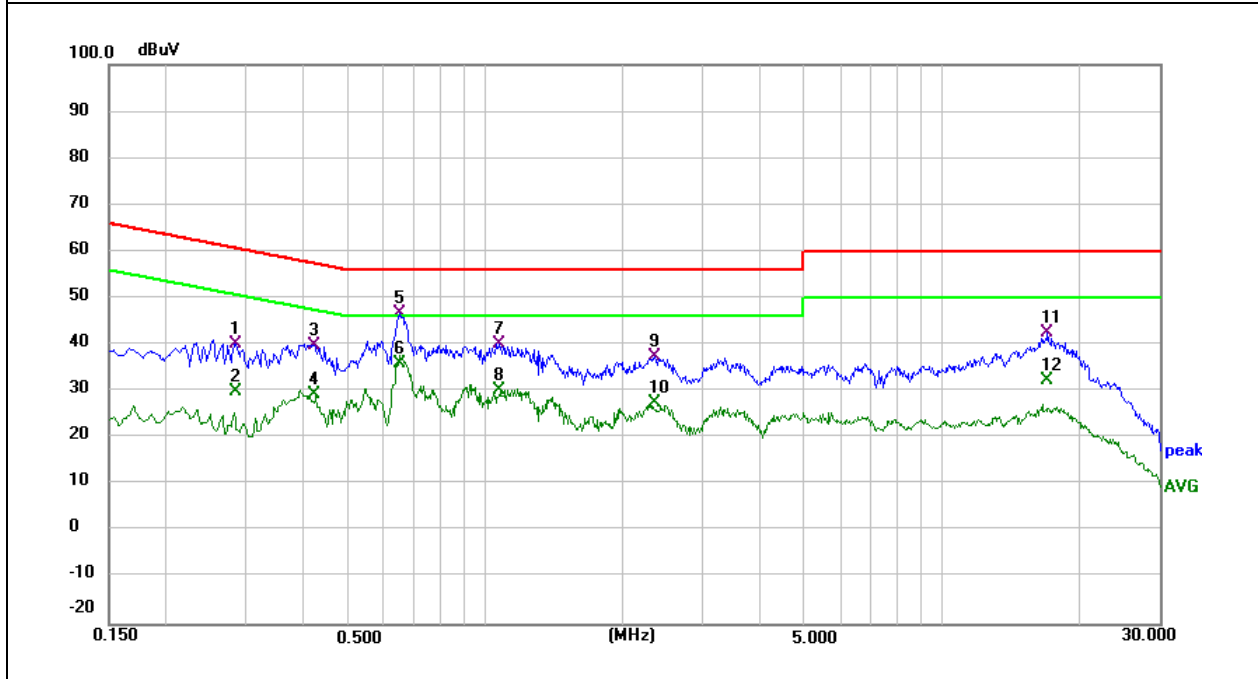

EUT:	Tablet PC	Model Name. :	Tab 30 WIFI
Temperature:	24.5 °C	Relative Humidity:	52%
Pressure:	1010hPa	Test Date:	2023/12/18
Test Mode:	Mode 1-battery 2	Phase :	N
Test Voltage:	DC 5V from PC AC 120V/60Hz		

Frequency (MHz)	Reading Level (dBμV)	Correct Factor (dB)	Measurement (dBμV)	Limits (dBμV)	Margin (dB)	Remark
0.2730	27.70	10.18	37.88	61.03	-23.15	QP
0.2730	16.84	10.18	27.02	51.03	-24.01	AVG
0.6646	35.30	10.97	46.27	56.00	-9.73	QP
0.6646	21.33	10.97	32.30	46.00	-13.70	AVG
1.3098	28.09	12.28	40.37	56.00	-15.63	QP
1.3098	17.97	12.28	30.25	46.00	-15.75	AVG
2.4090	28.47	9.66	38.13	56.00	-17.87	QP
2.4090	18.36	9.66	28.02	46.00	-17.98	AVG
4.2918	26.96	9.67	36.63	56.00	-19.37	QP
4.2918	16.66	9.67	26.33	46.00	-19.67	AVG
17.1084	33.21	9.71	42.92	60.00	-17.08	QP
17.1084	22.31	9.71	32.02	50.00	-17.98	AVG

Remark:

1. All readings are Quasi-Peak and Average values.
2. Factor = Insertion Loss + Cable Loss.

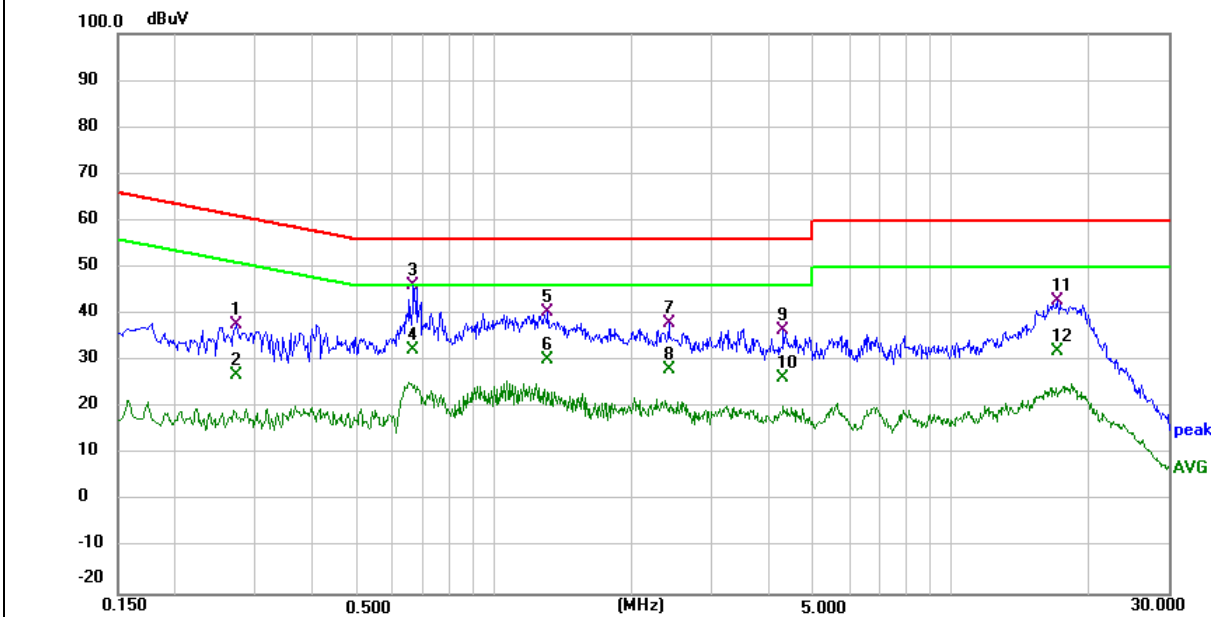

3.2 RADIATED EMISSION MEASUREMENT

3.2.1 LIMITS OF RADIATED EMISSION MEASUREMENT

FREQUENCY (MHz)	Class A (at 10m)	Class B (at 3m)
	dBuV/m	dBuV/m
30 ~ 88	39.0	40.0
88 ~ 216	43.5	43.5
216 ~ 960	46.5	46.0
Above 960	49.5	54.0

Notes:

- (1) The limit for radiated test was performed according to as following:
FCC PART 15B /ICES-003.
- (2) The tighter limit applies at the band edges.
- (3) Emission level (dBuV/m)=20log Emission level (uV/m).

3.2.2 TEST PROCEDURE

Test Arrangement for Radiated Emissions up to 1 GHz

- a. The EUT was placed on the top of a rotating table 0.8 meters above the ground at an accredited test facility. The table was rotated 360 degrees to determine the position of the highest radiation.
- b. The EUT was set 3 meters away from the interference-receiving antenna, which was mounted on the top of a variable-height antenna tower.
- c. The antenna is a broadband antenna, and its height is varied from one meter to four meters above the ground to determine the maximum value of the field strength. Both horizontal and vertical polarizations of the antenna are set to make the measurement.
- d. For each suspected emission, the EUT was arranged to its worst case and then the antenna was tuned to heights from 1 meter to 4 meters and the rotatable table was turned from 0 degrees to 360 degrees to find the maximum reading.

Note: The resolution bandwidth and video bandwidth of test receiver/spectrum analyzer is 120kHz for quasi-peak detection (QP) at frequency below 1GHz.

Test Arrangement for Radiated Emissions above 1 GHz.

- a. The EUT was placed on the top of a rotating table 0.8 meters above the ground at an accredited chamber room. The table was rotated 360 degrees to determine the position of the highest radiation.
- b. The EUT was set 3 meters away from the interference-receiving antenna, which was mounted on the top of a variable-height antenna tower.
- c. The height of antenna can be varied from one meter to four meters, the height of adjustment depends on the EUT height and the antenna 3dB beamwidth both, to detect the maximum value of the field strength.Both horizontal and vertical polarizations of the antenna are set to make the measurement.
- d. For each suspected emission, the EUT was arranged to its worst case and then the antenna was tuned to heights and the rotatable table was turned from 0 degrees to 360 degrees to find the maximum reading.

Note: For the hand-held device, the EUT should be measured for all 3 axes and only the worst case is recorded in the report

During the radiated emission test, according to ANSI C63.4-2014(4.2), the Spectrum Analyzer was set with the following configurations:

Frequency Band (MHz)	Function	Resolution bandwidth	Video Bandwidth
30 to 1000	QP	120 kHz	300 kHz
Above 1000	Peak	1 MHz	3 MHz
	Avg	1 MHz	10 Hz

3.2.3 TEST SETUP

For Radiated Emission 30~1000MHz

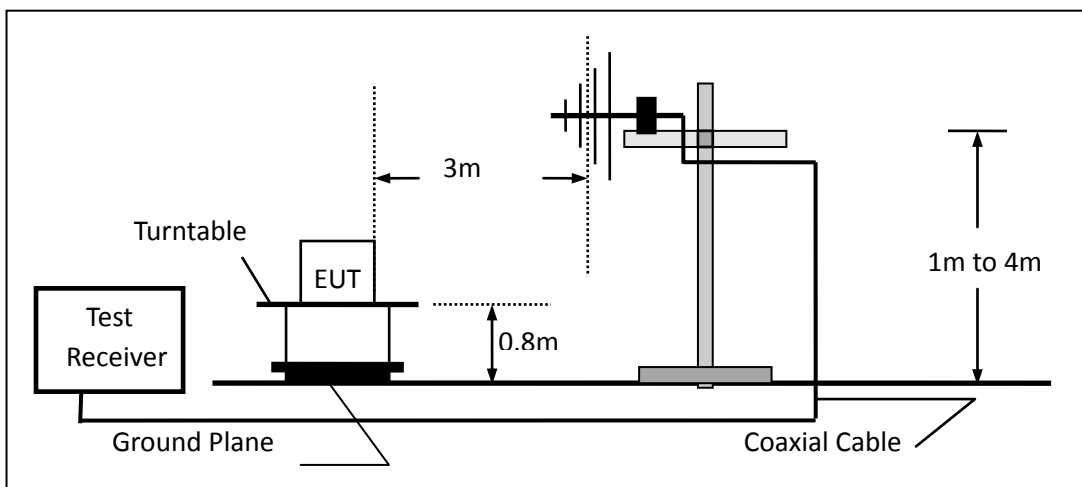

(B) Radiated Emission Test Set-Up Frequency Above 1GHz

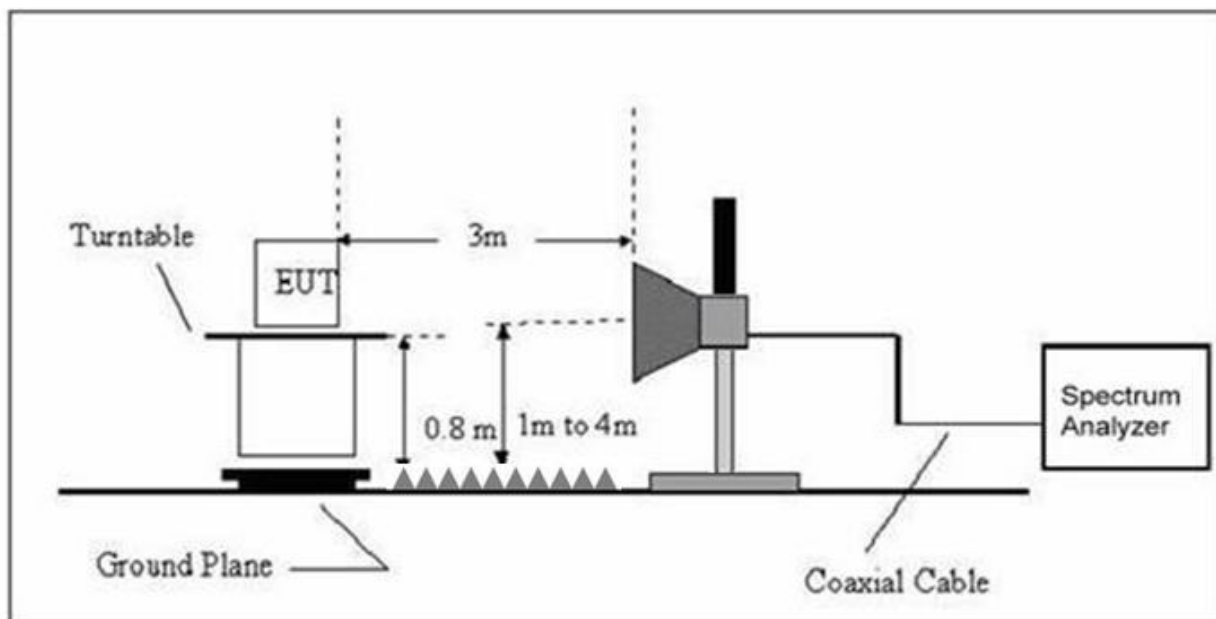

3.2.4 TEST RESULTS

TEST RESULTS (30~1000 MHz)

EUT:	Tablet PC	Model Name:	Tab 30 WIFI
Temperature:	24.5 °C	Relative Humidity:	55%
Pressure:	1010 hPa	Test Date :	2023/12/25
Test Mode :	Mode 1	Polarization :	Horizontal
Test Power :	DC 5V from PC AC 120V/60Hz		

Polar (H/V)	Frequency	Meter Reading	Factor	Emission Level	Limits	Margin	Remark
	(MHz)	(dBuV)	(dB)	(dBuV/m)	(dBuV/m)	(dB)	
H	56.3948	8.52	12.59	21.11	40.00	-18.89	QP
H	111.7380	7.20	18.31	25.51	43.50	-17.99	QP
H	175.0368	9.89	17.06	26.95	43.50	-16.55	QP
H	251.1804	14.88	18.85	33.73	46.00	-12.27	QP
H	360.4476	17.47	22.08	39.55	46.00	-6.45	QP
H	721.7259	13.92	28.15	42.07	46.00	-3.93	QP

Remark:
Factor = Antenna Factor + Cable Loss - Amplifier.

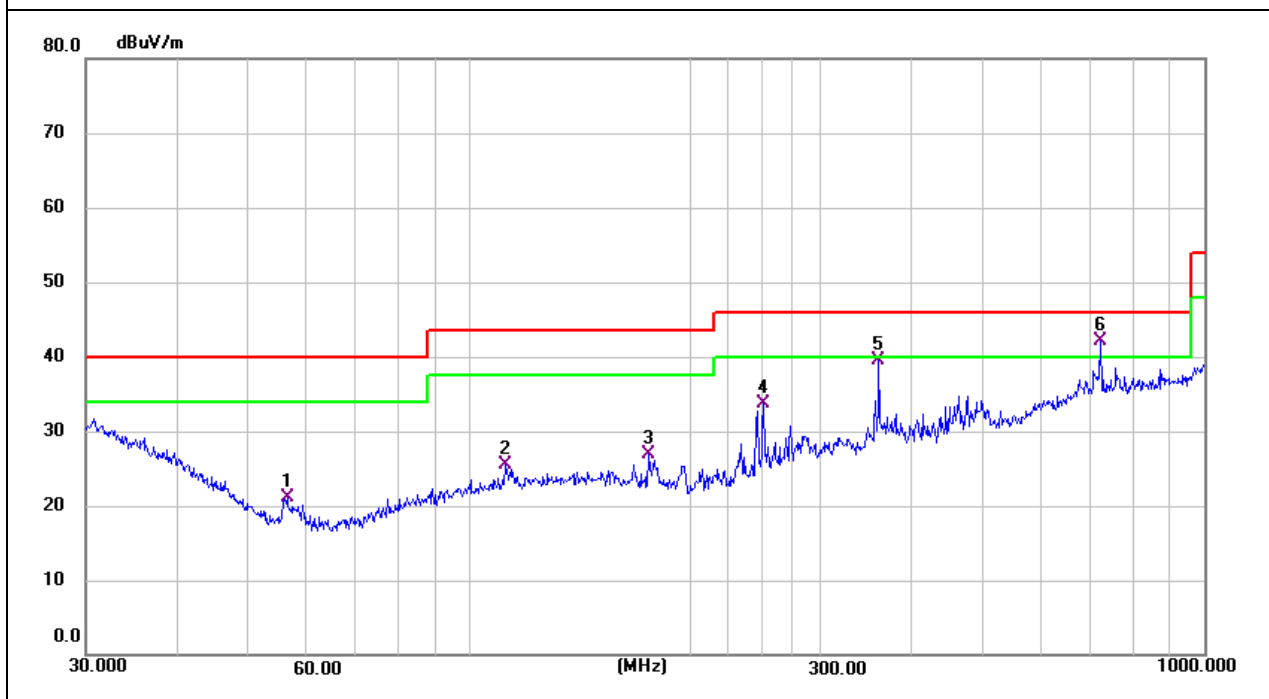

EUT:	Tablet PC	Model Name :	Tab 30 WIFI
Temperature:	24.5 °C	Relative Humidity:	55%
Pressure:	1010 hPa	Test Date :	2023/12/25
Test Mode :	Mode 1	Polarization :	Vertical
Test Power :	DC 5V from PC AC 120V/60Hz		

Polar (H/V)	Frequency	Meter Reading	Factor	Emission Level	Limits	Margin	Remark
	(MHz)	(dBuV)	(dB)	(dBuV/m)	(dBuV/m)	(dB)	
V	56.0007	14.31	12.65	26.96	40.00	-13.04	QP
V	156.4578	8.20	18.12	26.32	43.50	-17.18	QP
V	317.7011	7.68	20.34	28.02	46.00	-17.98	QP
V	472.1760	9.16	24.36	33.52	46.00	-12.48	QP
V	627.2738	9.08	26.69	35.77	46.00	-10.23	QP
V	721.7259	12.34	28.15	40.49	46.00	-5.51	QP

Remark:
 Factor = Antenna Factor + Cable Loss - Amplifier.

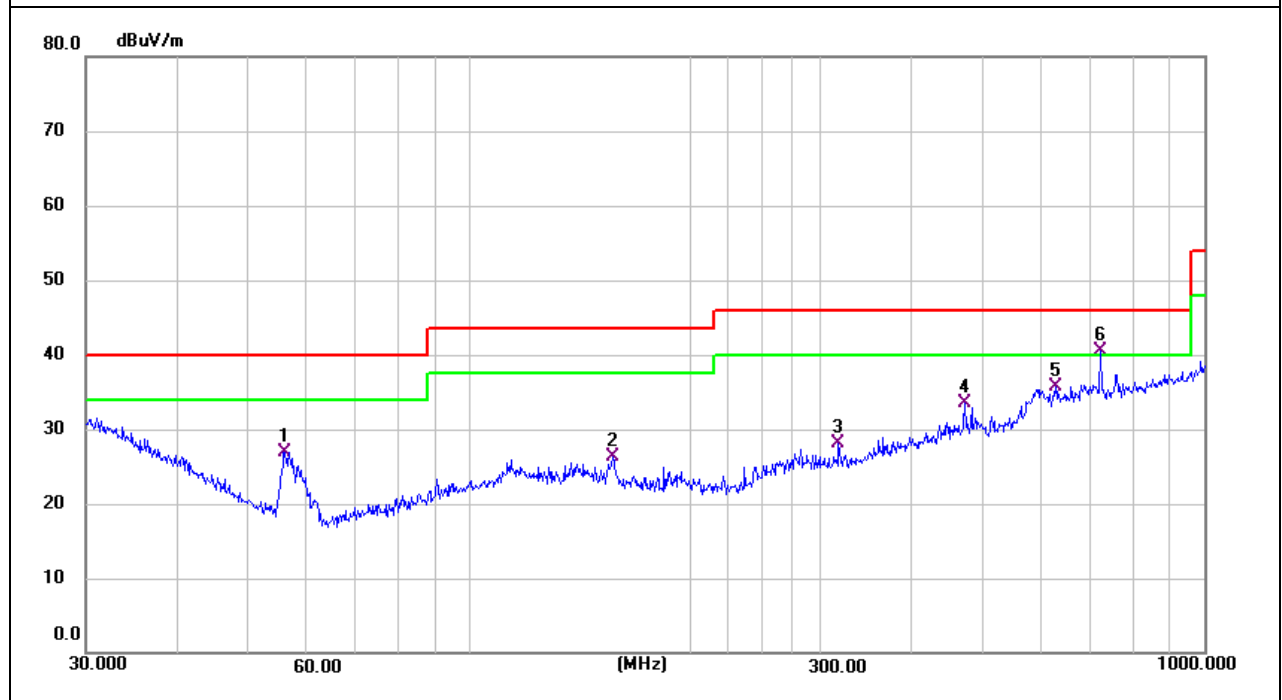

EUT:	Tablet PC	Model Name:	Tab 30 WIFI
Temperature:	24.5 °C	Relative Humidity:	55%
Pressure:	1010 hPa	Test Date :	2023/12/25
Test Mode :	Mode 1-battery 2	Polarization :	Horizontal
Test Power :	DC 5V from PC AC 120V/60Hz		

Polar (H/V)	Frequency	Meter Reading	Factor	Emission Level	Limits	Margin	Remark
	(MHz)	(dBuV)	(dB)	(dBuV/m)	(dBuV/m)	(dB)	
H	32.1794	6.44	25.21	31.65	40.00	-8.35	QP
H	134.5591	13.46	18.67	32.13	43.50	-11.37	QP
H	175.0367	13.94	17.06	31.00	43.50	-12.50	QP
H	314.3764	15.01	20.28	35.29	46.00	-10.71	QP
H	345.5952	14.78	21.46	36.24	46.00	-9.76	QP
H	721.7258	9.65	28.15	37.80	46.00	-8.20	QP

Remark:
 Factor = Antenna Factor + Cable Loss - Amplifier.

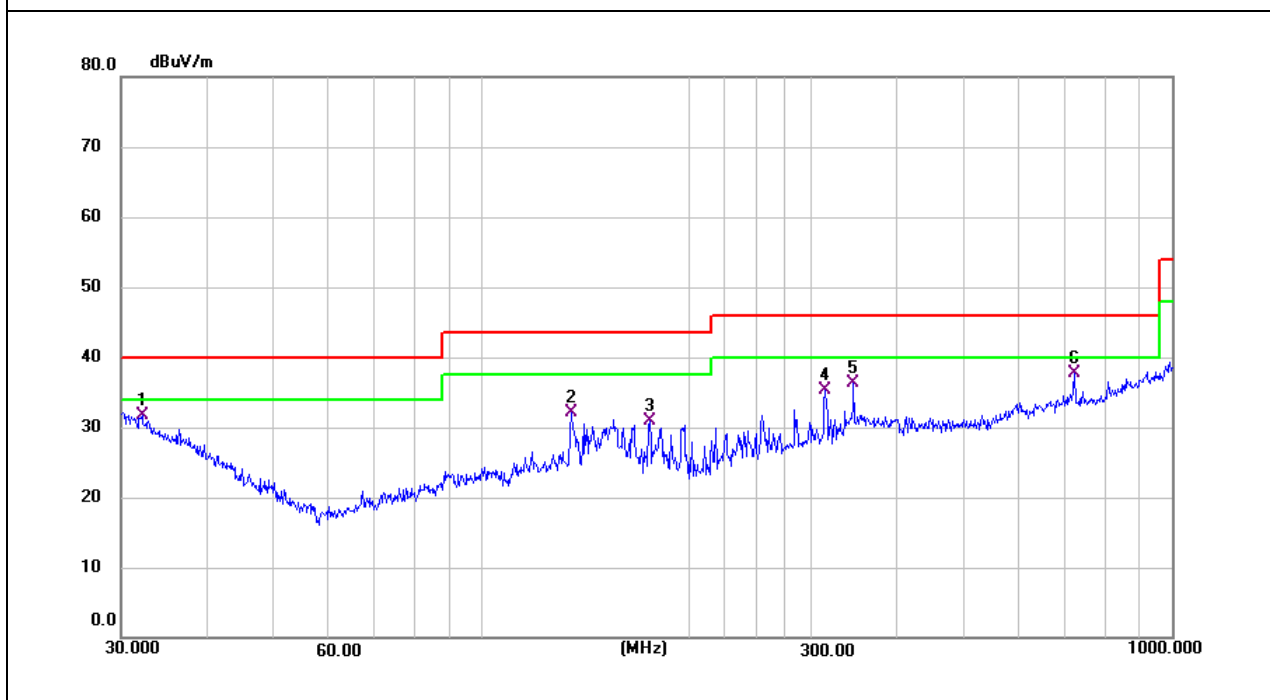

EUT:	Tablet PC	Model Name :	Tab 30 WIFI
Temperature:	24.5 °C	Relative Humidity:	55%
Pressure:	1010 hPa	Test Date :	2023/12/25
Test Mode :	Mode 1-battery 2	Polarization :	Vertical
Test Power :	DC 5V from PC AC 120V/60Hz		

Polar (H/V)	Frequency	Meter Reading	Factor	Emission Level	Limits	Margin	Remark
	(MHz)	(dBuV)	(dB)	(dBuV/m)	(dBuV/m)	(dB)	
V	31.1797	5.81	25.76	31.57	40.00	-8.43	QP
V	165.4866	15.10	17.60	32.70	43.50	-10.80	QP
V	181.2834	14.32	16.70	31.02	43.50	-12.48	QP
V	254.7283	11.57	19.04	30.61	46.00	-15.39	QP
V	345.5952	9.91	21.46	31.37	46.00	-14.63	QP
V	721.7258	9.23	28.15	37.38	46.00	-8.62	QP

Remark:
 Factor = Antenna Factor + Cable Loss - Amplifier.

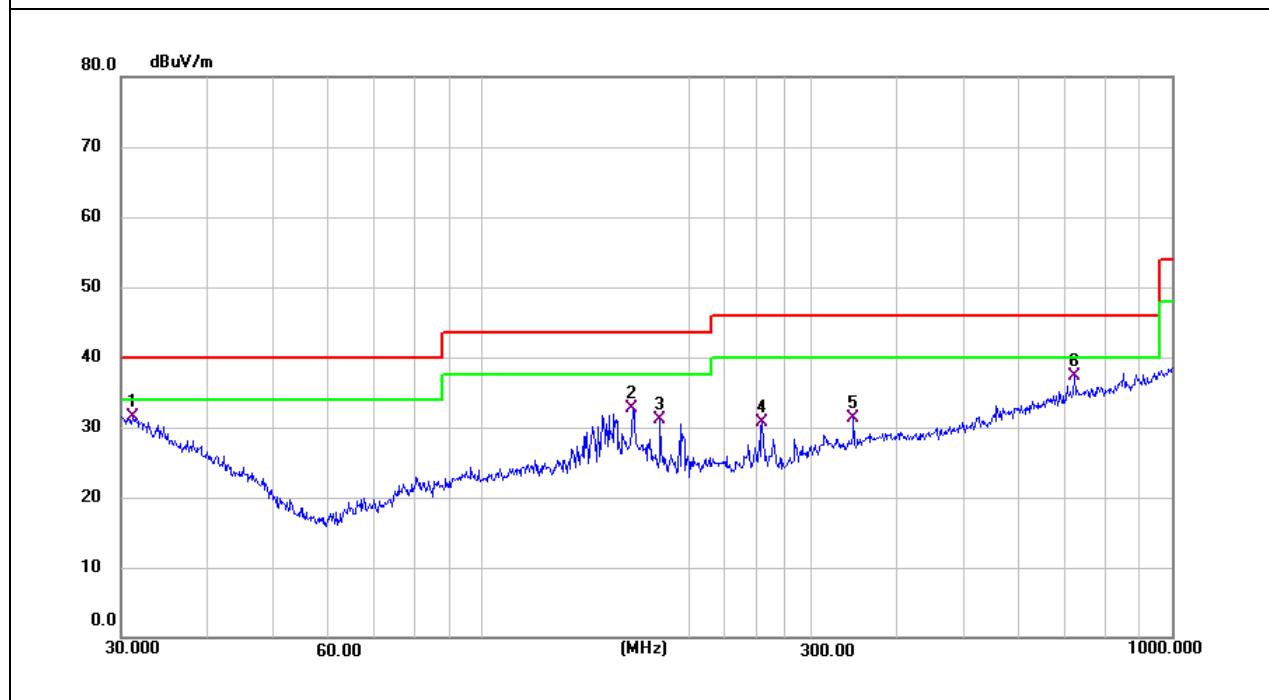

3.2.5 TEST RESULTS(1000~18000MHz)

EUT:	Tablet PC	Model Name :	Tab 30 WIFI
Temperature:	24.5 °C	Relative Humidity:	55%
Pressure:	1010 hPa	Test Date :	2023/12/16
Test Mode :	Mode 1		
Test Power :	DC 5V from PC AC 120V/60Hz		

All the modulation modes have been tested, and the worst result was report as below:

Polar (H/V)	Frequency	Reading	Correct	Result	Limit	Over Limit	Remark
	(MHz)	(dBuV/m)	dB/m	(dBuV/m)	(dBuV/m)	(dB)	
V	14277.000	53.05	2.96	56.01	74.00	-17.99	peak
V	14277.000	35.78	2.96	38.74	54.00	-15.26	AVG
V	16606.000	53.64	4.62	58.26	74.00	-15.74	peak
V	16606.000	37.23	4.62	41.85	54.00	-12.15	AVG
V	17626.000	53.80	6.00	59.80	74.00	-14.20	peak
V	17626.000	37.25	6.00	43.25	54.00	-10.75	AVG
H	14362.000	52.90	3.45	56.35	74.00	-17.65	peak
H	14362.000	35.10	3.45	38.55	54.00	-15.45	AVG
H	16606.000	54.09	4.62	58.71	74.00	-15.29	peak
H	16606.000	37.23	4.62	41.85	54.00	-12.15	AVG
H	17575.000	54.67	6.14	60.81	74.00	-13.19	peak
H	17575.000	37.66	6.14	43.80	54.00	-10.20	AVG

EUT:	Tablet PC	Model Name :	Tab 30 WIFI
Temperature:	24.5 °C	Relative Humidity:	55%
Pressure:	1010 hPa	Test Date :	2023/12/16
Test Mode :	Mode 1-battery 2		
Test Power :	DC 5V from PC AC 120V/60Hz		

All the modulation modes have been tested, and the worst result was report as below:

Polar (H/V)	Frequency	Reading	Correct	Result	Limit	Over Limit	Remark
	(MHz)	(dBuV/m)	dB/m	(dBuV/m)	(dBuV/m)	(dB)	
V	2445.000	57.97	-18.63	39.34	74.00	-34.66	peak
V	2445.000	47.83	-18.63	29.20	54.00	-24.80	AVG
V	3805.000	51.95	-11.91	40.04	74.00	-33.96	peak
V	3805.000	42.01	-11.91	30.10	54.00	-23.90	AVG
V	4570.000	52.46	-8.46	44.00	74.00	-30.00	peak
V	4570.000	42.96	-8.46	34.50	54.00	-19.50	AVG
V	6083.000	53.17	-6.55	46.62	74.00	-27.38	peak
V	6083.000	42.85	-6.55	36.30	54.00	-17.70	AVG
V	8208.000	51.30	-2.89	48.41	74.00	-25.59	peak
V	8208.000	41.01	-2.89	38.12	54.00	-15.88	AVG
V	9738.000	51.81	-0.96	50.85	74.00	-23.15	peak
V	9738.000	41.16	-0.96	40.20	54.00	-13.80	AVG
H	2649.000	56.43	-17.51	38.92	74.00	-35.08	peak
H	2649.000	45.53	-17.51	28.02	54.00	-25.98	AVG
H	4519.000	53.60	-8.36	45.24	74.00	-28.76	peak
H	4519.000	33.69	-8.36	25.33	54.00	-28.67	AVG
H	6049.000	53.93	-6.62	47.31	74.00	-26.69	peak
H	6049.000	43.73	-6.62	37.11	54.00	-16.89	AVG
H	7290.000	49.53	-3.50	46.03	74.00	-27.97	peak
H	7290.000	35.86	-3.50	32.36	54.00	-21.64	AVG
H	8633.000	48.93	-1.86	47.07	74.00	-26.93	peak
H	8633.000	38.96	-1.86	37.10	54.00	-16.90	AVG
H	10792.000	49.66	0.43	50.09	74.00	-23.91	peak
H	10792.000	39.77	0.43	40.20	54.00	-13.80	AVG

Remark:

Result = Reading + Correct, Over Limit= Result - Limit

Note: Only the worst results data points are reported in the report.

Other emissions are attenuated 20dB below the limit that does not recorded in the report.

END OF REPORT