

FCC CFR47 PART 22H, 24E, 27 CERTIFICATION TEST REPORT FCC ID: 2A7DX-BV4800PRO

Product: Mobile Phone
Trade Mark: Blackview
Model No.: BV4800 Pro
Family Model: N/A
Report No.: S24082201502006
Issue Date: Sept. 18, 2024

Prepared for

DOKE COMMUNICATION (HK) LIMITED
19H MAXGRAND PLAZA NO 3 TAI YAU STREET SAN PO KONG KL

Prepared by

Shenzhen NTEK Testing Technology Co., Ltd.
1/F, Building E, Fenda Science Park, Sanwei Community,
Xixiang Street Bao'an District, Shenzhen 518126 P.R. China
Tel. 400-800-6106, 0755-2320 0050, 0755-2320 0090
Website: <http://www.ntek.org.cn>

TEST RESULT CERTIFICATION

Applicant's name : DOKE COMMUNICATION (HK) LIMITED
Address..... : 19H MAXGRAND PLAZA NO 3 TAI YAU STREET SAN PO
 KONG KL
Manufacturer's Name..... : Shenzhen DOKE Electronic Co., Ltd
Address..... : 801, Building3, 7th Industrial Zone, Yulv Community, Yutang Road,
 Guangming District, Shenzhen, China.
Product name..... : Mobile Phone
Model and/or type reference .. : BV4800 Pro
Trade Mark..... : Blackview
Family Model..... : N/A
Test Sample Number..... S240822015001
Standards..... : FCC CFR 47 Part 22H, Part 24E, Part 27
Test procedure : ANSI C63.26:2015
 ANSI/TIA-603-E-2016

This device described above has been tested by NTEK, and the test results show that the equipment under test (EUT) is in compliance with the FCC requirements. And it is applicable only to the tested sample identified in the report.

This report shall not be reproduced except in full, without the written approval of NTEK, this document may be altered or revised by NTEK, personal only, and shall be noted in the revision of the document.

Date of Test

Date (s) of performance of tests..... Aug. 22, 2024 ~ Sept. 18, 2024

Date of Issue Sept. 18, 2024

Test Result **Pass**

Prepared By : Joe Yan
 Joe Yan
 (Project Engineer)

Reviewed By : Aaron Cheng
 Aaron Cheng
 (Supervisor)

Approved By : Alex Li
 Alex Li
 (Manager)

TABLE OF CONTENTS

| | |
|---|-----------|
| 1. GENERAL INFORMATION..... | 5 |
| 1. GENERAL INFORMATION..... | 5 |
| 1.1 PRODUCT DESCRIPTION | 5 |
| 1.2 RELATED SUBMITTAL(S) / GRANT (S)..... | 6 |
| 1.3 TEST METHODOLOGY | 6 |
| 1.4 TEST FACILITY..... | 6 |
| MEASUREMENT UNCERTAINTY | 6 |
| 1.5 SPECIAL ACCESSORIES..... | 6 |
| 1.6 WORST-CASE CONFIGURATION AND MODE..... | 6 |
| 2. SYSTEM TEST CONFIGURATION | 7 |
| 2.1 EUT CONFIGURATION..... | 7 |
| 2.2 EUT EXERCISE | 7 |
| 2.3 CONFIGURATION OF EUT SYSTEM..... | 7 |
| 2.4 TEST SETUP..... | 8 |
| 3.TEST AND MEASUREMENT EQUIPMENT | 9 |
| 4. OUTPUT POWER..... | 11 |
| 4.1 OUTPUT POWER MEASUREMENT | 11 |
| 5. OCCUPIED BANDWIDTH | 13 |
| 6. BANEDGE AND EMISSION MASK..... | 14 |
| 7. OUT OF BAND EMISSIONS | 16 |
| 7.1 MEASUREMENT METHOD | 16 |
| 8. RADIATED MEASUREMENT | 17 |
| 8.1. RADIATED POWER (ERP & EIRP)..... | 17 |
| 8.2 LTE BAND 2..... | 18 |
| 8.3 LTE BAND 4..... | 21 |
| 8.4 LTE BAND 5..... | 24 |
| 8.5 LTE BAND 7..... | 26 |

| | |
|--|-----------|
| 8.6 LTE BAND 12 | 28 |
| 8.7 LTE BAND 17 | 30 |
| 8.8 LTE BAND 41 | 32 |
| 9. SPURIOUS RADIATION EMISSION | 34 |
| 9.1 LTE BAND 2 | 36 |
| 9.2 LTE BAND 4 | 38 |
| 9.3 LTE BAND 5 | 40 |
| 9.4 LTE BAND 7 | 42 |
| 9.5 LTE BAND 12 | 44 |
| 9.6 LTE BAND 17 | 46 |
| 9.7 LTE BAND 41 | 48 |
| 10. FREQUENCY STABILITY | 50 |
| 10.1 LTE BAND 2 | 51 |
| 10.2 LTE BAND 4 | 53 |
| 10.3 LTE BAND 5 | 55 |
| 10.4 LTE BAND 7 | 57 |
| 10.5 LTE BAND 12 | 59 |
| 10.6 LTE BAND 17 | 61 |
| 10.7 LTE BAND 41 | 63 |
| 11. PEAK-TO-AVERAGE RATIO | 65 |
| 11.1 Description of the PAR Measurement | 65 |
| 11.2 Measuring Instruments | 65 |
| 11.3 Test Procedures | 65 |
| 11.4 Test Setup | 66 |

1. GENERAL INFORMATION

1.1 PRODUCT DESCRIPTION

A major technical description of EUT is described as following:

| | |
|--|--|
| Product Designation: | Mobile Phone |
| Trade Mark | Blackview |
| Model Name | BV4800 Pro |
| Family Model | N/A |
| Model Difference | N/A |
| FCC ID: | 2A7DX-BV4800PRO |
| Frequency Bands: | U.S. Bands: <input checked="" type="checkbox"/> LTE FDD Band 2, 4, 5, 7,12, 17 TDD Band 41 |
| Frequency Range: | LTE FDD Band 2 Uplink: 1850MHz-1910MHz, Downlink: 1930MHz-1990MHz; LTE FDD Band 4 Uplink: 1710MHz-1755MHz, Downlink: 2110MHz-2155MHz; LTE FDD Band 5 Uplink: 824MHz-849MHz, Downlink: 869MHz-894MHz; LTE-FDD Band 7 Uplink: 2500MHz-2570MHz, Downlink: 2620MHz-2690MHz; LTE FDD Band 12 Uplink: 699MHz-716MHz, Downlink: 729MHz-746MHz; LTE FDD Band 17 Uplink: 704MHz-716MHz, Downlink: 734MHz-746MHz; LTE TDD Band 41 Uplink& Downlink: 2496MHz-2690MHz, |
| Type of Modulation: | QPSK/16QAM/64QAM(Only Downlink) |
| Power Class | Class 3 |
| SIM Card: | SIM 1 and SIM 2 is a chipset unit and tested as a single chipset. The SIM 1 is chosen for test. |
| Antenna: | FPCAntenna |
| Antenna gain: | Band 2: 0.2 dBi, Band 4: 0.2dBi, Band 5: -3.1 dBi, Band 7: -1.1dBi, Band 12: -3.5dBi, Band 17: -3.5 dBi, Band 41:-0.8 dBi |
| Adapter | Model: HJ-0502000-US Input: 100-240V~50/60Hz 0.3A Output: 5.0V $\overline{\text{---}}$ 2.0A 10.0W |
| Battery | DC 3.85V, 5180mAh, 19.94Wh |
| Power supply | DC 3.85V from battery or DC 5V from adapter |
| Extreme Vol. Limits: | DC 3.27V to DC 4.43V (Nominal DC 3.85V) (Note 1) |
| HW Version | Z665_MBA2_BOM2 |
| SW Version | BV4800Pro_NEU_Z665_V1.0 |
| ** Note1: The High Voltage DC 4.43V and Low Voltage 3.27V was declared by manufacturer, The EUT couldn't be operate normally with higher or lower voltage. | |

1.2 RELATED SUBMITTAL(S) / GRANT (S)

This submittal(s) (test report) is intended for **FCC ID: 2A7DX-BV4800PRO** filing to comply with the FCC Part 22H&24E&27.

1.3 TEST METHODOLOGY

The tests documented in this report were performed in accordance with ANSI/TIA-603-E-2016, FCC CFR 47 Part 2, Part 22, Part 24, Part 27, ANSI C63.26:2015.

1.4 TEST FACILITY

The test site used to collect the radiated data is located at:

ShenZhen NTEK Testing Technology Co., Ltd.

1/F, Building E, Fenda Science Park, Sanwei Community, Xixiang Street, Bao'an District, Shenzhen 518126 P.R.China.

The test site is constructed and calibrated to meet the FCC requirements in documents ANSI C63.26:2015& ANSI C63.4: 2014.

FCC Registration No.:463705

IC Registration No.:9270A,

CNAS Registration No.:L5516

MEASUREMENT UNCERTAINTY

The reported uncertainty of measurement, where expended uncertainty U is based on a standard uncertainty multiplied by a coverage factor of k=2, providing a level of confidence of approximately 95 %.

| No. | Item | Uncertainty |
|-----|---|-------------|
| 1 | Measuring Uncertainty for a Level of Confidence of 95% (U = 2Uc(y)) | 2.5dB |
| | | |

1.5 SPECIAL ACCESSORIES

The battery and the charger, earphone supplied by the applicant were used as accessories and being tested with EUT intended for FCC grant together.

1.6 WORST-CASE CONFIGURATION AND MODE

The worst-case scenario for all measurements is based on the investigation results.

The device has LTE Bands of: Band 2/4/5/7/12/17/41

The RB Size was selected to measure for peak or average ERP and EIRP, which was based on the conducted power verification baseline data.

For the fundamental investigation of radiated emissions, the EUT is investigated for vertical and horizontal antenna orientations and X Y and Z orientations of the EUT alone. After the investigations the worst case was determined to be at X orientation for all LTE bands.

2. SYSTEM TEST CONFIGURATION

2.1 EUT CONFIGURATION

The EUT configuration for testing is installed on RF field strength measurement to meet the Commission's requirement and operating in a manner which intends to maximize its emission characteristics in a continuous normal application.

2.2 EUT EXERCISE

The Transmitter was operated in the maximum output power mode through Communication Tester. The TX frequency was fixed which was for the purpose of the measurements.

2.3 CONFIGURATION OF EUT SYSTEM

Table 2-1 Equipment Used in EUT System

| Item | Equipment | Model No. | ID or Specification | Note |
|------|--------------|------------|-------------------------|------|
| 1 | Mobile Phone | BV4800 Pro | FCC ID: 2A7DX-BV4800PRO | EUT |
| | | | | |
| | | | | |

*Note: All the accessories have been used during the test.
the following "EUT" in setup diagram means EUT system.*

2.4 TEST SETUP

For Radiated Test Cases

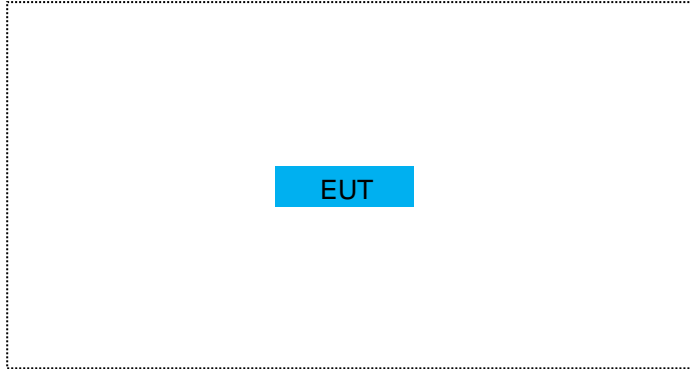

For Conducted Output Power

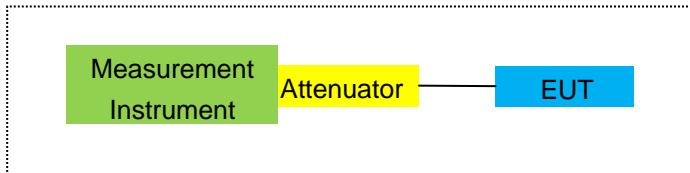

For Peak-to Average Ratio, Occupied Bandwidth, Conducted Band edge and Conducted Spurious Emission

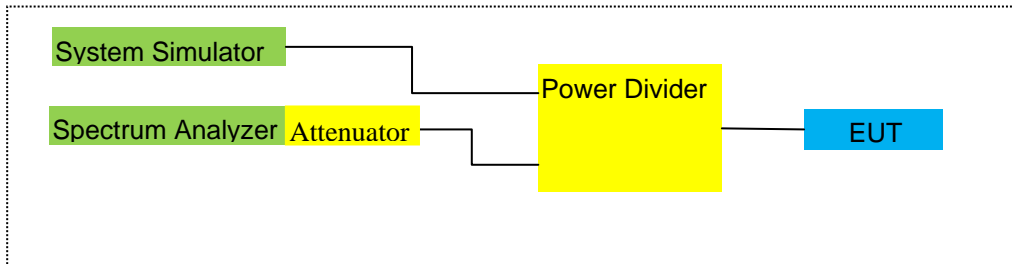

For Frequency Stability

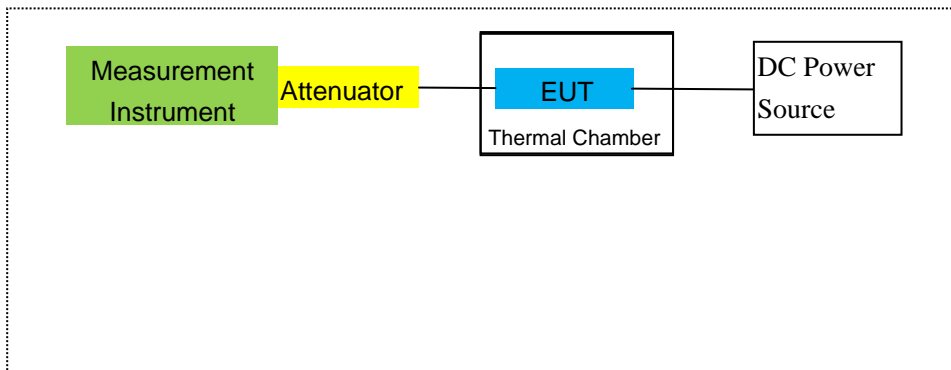

Note: EUT built-in battery-powered, the battery is fully-charged.

3. TEST AND MEASUREMENT EQUIPMENT

The following test and measurement equipment was utilized for the tests documented in this report:

| Item | Kind of Equipment | Manufacturer | Type No. | Serial No. | Last calibration | Calibrated until | Calibration period |
|------|-----------------------|--------------|-------------|--------------|------------------|------------------|--------------------|
| 1 | MXA Signal Analyzer | Agilent | N9020A | MY49100060 | 2024.04.25 | 2025.04.24 | 1 year |
| 2 | Test Receiver | R&S | ESPI | 101318 | 2024.04.26 | 2025.04.25 | 1 year |
| 3 | Bilog Antenna | TESEQ | CBL6111D | 31216 | 2024.05.12 | 2025.05.11 | 1 year |
| 4 | 50Ω Coaxial Switch | Anritsu | MP59B | 6200983705 | 2024.04.26 | 2027.04.25 | 3 year |
| 5 | Horn Antenna | EM | EM-AH-10180 | 2011071402 | 2024.05.12 | 2027.05.11 | 3 year |
| 6 | Horn Ant | Schwarzbeck | BBHA 9170 | 9170-181 | 2024.05.12 | 2027.05.11 | 3 year |
| 7 | Amplifier | EM | EM-30180 | 060538 | 2024.04.26 | 2025.04.25 | 1 year |
| 8 | Loop Antenna | ARA | PLA-1030/B | 1029 | 2024.03.12 | 2025.03.11 | 1 year |
| 9 | Power Meter | R&S | NRVS | 100696 | 2024.04.26 | 2025.04.25 | 1 year |
| 10 | Power Sensor | R&S | URV5-Z4 | 0395.1619.05 | 2024.04.26 | 2025.04.25 | 1 year |
| 11 | Test Cable | N/A | R-01 | N/A | 2022.06.17 | 2025.06.16 | 3 year |
| 12 | Test Cable | N/A | R-02 | N/A | 2022.06.17 | 2025.06.16 | 3 year |
| 13 | Test Cable | N/A | R-03 | N/A | 2022.06.17 | 2025.06.16 | 3 year |
| 14 | Test Receiver | R&S | ESCI | 101160 | 2024.04.26 | 2025.04.25 | 1 year |
| 15 | LISN | R&S | ENV216 | 101313 | 2024.04.25 | 2025.04.24 | 1 year |
| 16 | LISN | EMCO | 3816/2 | 00042990 | 2024.04.25 | 2025.04.24 | 1 year |
| 17 | 50Ω Coaxial Switch | Anritsu | MP59B | 6200264417 | 2024.03.12 | 2025.03.11 | 1 year |
| 18 | Passive Voltage Probe | R&S | ESH2-Z3 | 100196 | 2024.03.12 | 2025.03.11 | 1 year |
| 19 | Test Cable | N/A | C01 | N/A | 2023.05.06 | 2026.05.05 | 3 year |
| 20 | Test Cable | N/A | C02 | N/A | 2023.05.06 | 2026.05.05 | 3 year |
| 21 | Test Cable | N/A | C03 | N/A | 2023.05.06 | 2026.05.05 | 3 year |
| 22 | Spectrum Analyzer | agilent | e4440a | us44300399 | 2024.03.12 | 2025.03.11 | 1 year |
| 23 | test receiver | R&S | ESCI | a0304218 | 2024.03.12 | 2025.03.11 | 1 year |
| 24 | Communication Tester | R&S | CMU200 | A0304247 | 2024.03.12 | 2025.03.11 | 1 year |
| 25 | Thermal Chamber | Ten Billion | TTC-B3C | TBN-960502 | 2024.03.12 | 2025.03.11 | 1 year |

| | | | | | | | |
|----|-----------------|-----|----------|-----------------|------------|------------|--------|
| 26 | DC Power Source | N/A | PS-6005D | 2017040292 3 | 2024.04.25 | 2027.04.24 | 3 year |
|----|-----------------|-----|----------|-----------------|------------|------------|--------|

Note: Each piece of equipment is scheduled for calibration once a year except the Test Cable& DC Power Source which is scheduled for calibration every 3 years.

Measurement Software

| Item | Manufacturer | Software Name | Software Version | Description |
|------|--------------|---------------|------------------|-------------------|
| 1 | MWRFTest | MTS 8200 | 2.0 | RF Conducted Test |
| 2 | Farad | EZ-EMC_RE | AIT-03A | RadiatedTest |
| 3 | Farad | EZ-EMC_CE | AIT-03A | AC Conducted Test |

4. OUTPUT POWER

4.1 OUTPUT POWER MEASUREMENT

LTE Measurement Procedure:

All LTE bands conducted power peak and average are obtained from the CMW500 telecommunication test set. The following tests were conducted according to the test requirements outlined in section 6.2 of the 3GPP TS36.101 specification.

UE Power Class: 3 (23 +/- 2dBm). The allowed Maximum Power Reduction (MPR) for the maximum output power due to higher order modulation and transmit bandwidth configuration (resource blocks) is specified in Table 6.2.3-1 of the 3GPP TS36.101.

Table 6.2.3-1: Maximum Power Reduction (MPR) for Power Class 3

| Modulation | Channel bandwidth / Transmission bandwidth (RB) | | | | | | MPR (dB) |
|------------|---|---------|-------|--------|--------|--------|----------|
| | 1.4 MHz | 3.0 MHz | 5 MHz | 10 MHz | 15 MHz | 20 MHz | |
| QPSK | > 5 | > 4 | > 8 | > 12 | > 16 | > 18 | ≤ 1 |
| 16 QAM | ≤ 5 | ≤ 4 | ≤ 8 | ≤ 12 | ≤ 16 | ≤ 18 | ≤ 1 |
| 16 QAM | > 5 | > 4 | > 8 | > 12 | > 16 | > 18 | ≤ 2 |

The allowed A-MPR values specified below in Table 6.2.4.-1 of 3GPP TS36.101 are in addition to the allowed MPR requirements. All the measurements below were performed with A-MPR disabled, by using Network Signaling Value of "NS_01".3

Table 6.2.4-1: Additional Maximum Power Reduction (A-MPR)

| Network Signalling value | Requirements (sub-clause) | E-UTRA Band | Channel bandwidth (MHz) | Resources Blocks (N_{RB}) | A-MPR (dB) |
|--------------------------|---------------------------|--------------------------|-------------------------|-------------------------------|---------------|
| NS_01 | 6.6.2.1.1 | Table 5.5-1 | 1.4, 3, 5, 10, 15, 20 | Table 5.6-1 | NA |
| NS_03 | 6.6.2.2.1 | 2, 4, 10, 23, 25, 35, 36 | 3 | >5 | ≤ 1 |
| | | | 5 | >6 | ≤ 1 |
| | | | 10 | >6 | ≤ 1 |
| | | | 15 | >8 | ≤ 1 |
| | | | 20 | >10 | ≤ 1 |
| NS_04 | 6.6.2.2.2 | 41 | 5 | >6 | ≤ 1 |
| | | | 10, 15, 20 | See Table 6.2.4-4 | |
| NS_05 | 6.6.3.3.1 | 1 | 10, 15, 20 | ≥ 50 | ≤ 1 |
| NS_06 | 6.6.2.2.3 | 12, 13, 14, 17 | 1.4, 3, 5, 10 | Table 5.6-1 | n/a |
| NS_07 | 6.6.2.2.3 | 13 | 10 | Table 6.2.4-2 | Table 6.2.4-2 |
| | 6.6.3.3.2 | | | | |
| NS_08 | 6.6.3.3.3 | 19 | 10, 15 | > 44 | ≤ 3 |
| NS_09 | 6.6.3.3.4 | 21 | 10, 15 | > 40 | ≤ 1 |
| | | | | > 55 | ≤ 2 |
| NS_10 | | 20 | 15, 20 | Table 6.2.4-3 | Table 6.2.4-3 |
| NS_11 | 6.6.2.2.1 | 23 ¹ | 1.4, 3, 5, 10 | Table 6.2.4-5 | Table 6.2.4-5 |
| .. | | | | | |
| NS_32 | - | - | - | - | - |

Note 1: Applies to the lower block of Band 23, i.e. a carrier placed in the 2000-2010 MHz region.

Test data reference attachment.

5. OCCUPIED BANDWIDTH

RULE PART(S)

FCC: §2.1049

LIMITS

For reporting purposes only

TEST PROCEDURE

The transmitter output was connected to a calibrated coaxial cable and coupler, the other end of which was connected to a spectrum analyzer. The occupied bandwidth was measured with the spectrum analyzer at the low, middle and high channel in each band. The -26dB bandwidth was also measured and recorded.

MODES TESTED

Band 2/4/5/7/12/17/41

RESULTS

PASS

Test data reference attachment.

6. BANDEDGE AND EMISSION MASK

RULE PART(S)

FCC: §2.1051, §22.901, §22.917, §24.238, §27.53,
FCC: §22.359

LIMITS

FCC: §22.917, §24.238, §27.53

The power of any emission outside of the authorized operating frequency ranges must be attenuated below the transmitting power (P) by a factor of at least $43 + 10 \log (P)$ dB.

(m)(4) For mobile digital stations, the attenuation factor shall be not less than $40 + 10 \log (P)$ dB on all frequencies between the channel edge and 5 megahertz from the channel edge, $43 + 10 \log (P)$ dB on all frequencies between 5 megahertz and X megahertz from the channel edge, and $55 + 10 \log (P)$ dB on all frequencies more than X megahertz from the channel edge, where X is the greater of 6 megahertz or the actual emission bandwidth as defined in paragraph (m)(6) of this section. In addition, the attenuation factor shall not be less that $43 + 10 \log (P)$ dB on all frequencies between 2490.5 MHz and 2496 MHz and $55 + 10 \log (P)$ dB at or below 2490.5 MHz. Mobile Satellite Service licensees operating on frequencies below 2495 MHz may also submit a documented interference complaint against BRS licensees operating on channel BRS Channel 1 on the same terms and conditions as adjacent channel BRS or EBS licensees. Show citation box.

(c)(4) On all frequencies between 763-775 MHz and 793-805 MHz, by a factor not less than $65 + 10 \log (P)$ dB in a 6.25 kHz band segment, for mobile and portable stations;

FCC: §90.691 Emission mask requirements for EA-based systems.

(a) Out-of-band emission requirement shall apply only to the “outer” channels included in an EA license and to spectrum adjacent to interior channels used by incumbent licensees. The emission limits are as follows:

(1) For any frequency removed from the EA licensee's frequency block by up to and including 37.5 kHz, the power of any emission shall be attenuated below the transmitter power (P) in watts by at least $116 \log_{10}(f/6.1)$ decibels or $50 + 10 \log_{10}(P)$ decibels or 80 decibels, whichever is the lesser attenuation, where f is the frequency removed from the center of the outer channel in the block in kilohertz and where f is greater than 12.5 kHz.

(2) For any frequency removed from the EA licensee's frequency block greater than 37.5 kHz, the power of any emission shall be attenuated below the transmitter power (P) in watts by at least $43 + 10 \log_{10}(P)$ decibels or 80 decibels, whichever is the lesser attenuation, where f is the frequency removed from the center of the outer channel in the block in kilohertz and where f is greater than 37.5 kHz.

TEST PROCEDURE

The transmitter output was connected to a CMW500 Test Set and configured to operate at maximum power. The band edge emissions were measured at the required operating frequencies in each band on the Spectrum Analyzer.

For each band edge measurement:

Set the spectrum analyzer span to include the block edge frequency

Set a marker to point the corresponding band edge frequency in each test case.

Set resolution bandwidth to at least 1% of emission bandwidth.

MODES TESTED

Band 2/4/5/7/12/17/41

RESULTS

Test data reference attachment.

7. OUT OF BAND EMISSIONS

RULE PART(S)

FCC: §2.1051, §22.901, §22.917, §24.238, §27.53

LIMITS

1. The power of any emission outside of the authorized operating frequency ranges must be attenuated below the transmitting power (P) by a factor of at least $43 + 10 \log (P)$ dB.
2. The Band 7/41 emission outside of the authorized operating frequency ranges must be attenuated below the transmitting power (P) by a factor of at least $55 + 10 \log (P)$ dB.

TEST PROCEDURE

The RF output of the transmitter was connected to a spectrum analyzer through a calibrated coaxial cable. Sufficient scans were taken to show the out-of-band Emissions, if any, up to 10th harmonic. Multiple sweeps were recorded in maximum hold mode using a peak detector to ensure that the worst-case emissions were caught.

For each out of band emissions measurement:

Set RBW & VBW to 100 kHz for the measurement below 1 GHz, and 1 MHz for the measurement above 1 GHz.

MODES TESTED

Band 2/4/5/7/12/17/41

7.1 MEASUREMENT METHOD

The test set up and general procedure is similar to conducted peak output power test. Only different for setting the measurement configuration of the measuring instrument of Spectrum Analyzer.

Test data reference attachment.

8. RADIATED MEASUREMENT

8.1. RADIATED POWER (ERP & EIRP)

RULE PART(S)

FCC: §2.1046, §22.913, §24.232, §27.50

LIMITS:

22.913(a) - The ERP of mobile transmitters and auxiliary test transmitters must not exceed 7 Watts.

27.50 (c) (10) the following power and antenna height requirements apply to stations transmitting in the 698–746 MHz band, the portable stations (hand-held devices) are limited to 3 watts ERP.

27.50 (b)(10) Portable stations (hand-held devices) transmitting in the 746–757 MHz, 758–763 MHz, 776–793 MHz, and 805–806 MHz bands are limited to 3 watts ERP.

27.50 (d)(4) The following power and antenna height requirements apply to stations transmitting in the 1710–1755 MHz and 2110–2155 MHz bands: Fixed, mobile, and portable (hand-held) stations operating in the 1710–1755 MHz band are limited to 1 watt EIRP.

27.50 (h)(2) Mobile and other user stations. Mobile stations are limited to 2.0 watts EIRP. All user stations are limited to 2.0 watts transmitter output power.

90.635(b) The maximum output power of the transmitter for mobile stations is 100 watts (20 dBw).

TEST PROCEDURE

ANSI/TIA-603-E Clause 2.2.17

KDB 971168 v02r01 RF power output using broadband peak and average power meter method.

KDB 971168 D01 Power Meas License Digital Systems v02r01, "Measurement Guidance for Certification of Licensed Digital Transmitters"

MODES TESTED

Band 2/4/5/7/12/17/41

RESULTS

Pass

8.2 LTE BAND 2

| Radiated Power (EIRP) for Band 2 | | | | | | | | | | |
|----------------------------------|------------|-----------|----------------|------------------|---------------------|-------------------------|------------------------|------------|--------------------------|------------|
| Mode | RB/RB SIZE | Frequency | Result | | | | | | Polarization Of Max. ERP | Conclusion |
| | | | SG Level (dBm) | Cable Loss (dBm) | Antenna Factor (dB) | Max. EIRP Average (dBm) | Max. EIRP Average (mW) | | | |
| | | | | | | | | | | |
| 1.4MHz Band QPSK | 1/#Mid | 1850.7 | -2.47 | 3.76 | 28.24 | 22.01 | 158.855 | Horizontal | Pass | |
| | | 1880 | -1.94 | 3.91 | 28.22 | 22.37 | 172.584 | Horizontal | Pass | |
| | | 1909.3 | -2.20 | 3.93 | 28.20 | 22.07 | 161.065 | Horizontal | Pass | |
| 3.0MHz Band QPSK | 1/#Mid | 1851.5 | -2.47 | 3.77 | 28.23 | 21.99 | 158.125 | Horizontal | Pass | |
| | | 1880 | -2.17 | 3.91 | 28.24 | 22.16 | 164.437 | Horizontal | Pass | |
| | | 1908.5 | -2.23 | 3.94 | 28.25 | 22.08 | 161.436 | Horizontal | Pass | |
| 5.0MHz Band QPSK | 1/#Mid | 1852.5 | -2.22 | 3.77 | 28.31 | 22.32 | 170.608 | Horizontal | Pass | |
| | | 1880 | -1.80 | 3.91 | 28.22 | 22.51 | 178.238 | Horizontal | Pass | |
| | | 1907.5 | -1.81 | 3.94 | 28.20 | 22.45 | 175.792 | Horizontal | Pass | |
| 10.0MHz Band QPSK | 1/#Mid | 1855 | -2.49 | 3.79 | 28.33 | 22.05 | 160.325 | Horizontal | Pass | |
| | | 1880 | -1.75 | 3.95 | 28.22 | 22.52 | 178.649 | Horizontal | Pass | |
| | | 1905 | -1.91 | 3.97 | 28.19 | 22.31 | 170.216 | Horizontal | Pass | |
| 15.0MHz Band QPSK | 1/#Mid | 1857.5 | -2.23 | 3.79 | 28.34 | 22.32 | 170.608 | Horizontal | Pass | |
| | | 1880 | -1.65 | 3.95 | 28.22 | 22.62 | 182.810 | Horizontal | Pass | |
| | | 1902.5 | -1.75 | 3.97 | 28.18 | 22.46 | 176.198 | Horizontal | Pass | |
| 20.0MHz Band QPSK | 1/#Mid | 1860 | -2.14 | 3.81 | 28.35 | 22.40 | 173.780 | Horizontal | Pass | |
| | | 1880 | -1.96 | 3.96 | 28.22 | 22.30 | 169.824 | Horizontal | Pass | |
| | | 1900 | -1.80 | 4.00 | 28.16 | 22.36 | 172.187 | Horizontal | Pass | |
| 1.4MHz Band QPSK | 1/#Mid | 1850.7 | -2.81 | 3.76 | 28.24 | 21.67 | 146.893 | Vertical | Pass | |
| | | 1880 | -2.79 | 3.91 | 28.22 | 21.52 | 141.906 | Vertical | Pass | |
| | | 1909.3 | -3.07 | 3.93 | 28.20 | 21.20 | 131.826 | Vertical | Pass | |
| 3.0MHz Band QPSK | 1/#Mid | 1851.5 | -3.09 | 3.77 | 28.23 | 21.37 | 137.088 | Vertical | Pass | |
| | | 1880 | -2.92 | 3.91 | 28.24 | 21.41 | 138.357 | Vertical | Pass | |
| | | 1908.5 | -3.39 | 3.94 | 28.25 | 20.92 | 123.595 | Vertical | Pass | |
| 5.0MHz Band QPSK | 1/#Mid | 1852.5 | -3.22 | 3.77 | 28.31 | 21.32 | 135.519 | Vertical | Pass | |
| | | 1880 | -2.63 | 3.91 | 28.22 | 21.68 | 147.231 | Vertical | Pass | |
| | | 1907.5 | -3.75 | 3.94 | 28.20 | 20.51 | 112.460 | Vertical | Pass | |
| 10.0MHz Band QPSK | 1/#Mid | 1855 | -2.63 | 3.79 | 28.33 | 21.91 | 155.239 | Vertical | Pass | |
| | | 1880 | -2.61 | 3.95 | 28.22 | 21.66 | 146.555 | Vertical | Pass | |
| | | 1905 | -3.49 | 3.97 | 28.19 | 20.73 | 118.304 | Vertical | Pass | |

| | | | | | | | | | |
|-------------------------|--------|--------|-------|------|-------|-------|---------|----------|------|
| 15.0MHz Band QPSK | 1/#Mid | 1857.5 | -2.91 | 3.79 | 28.34 | 21.64 | 145.881 | Vertical | Pass |
| | | 1880 | -2.70 | 3.95 | 28.22 | 21.57 | 143.549 | Vertical | Pass |
| | | 1902.5 | -2.73 | 3.97 | 28.18 | 21.48 | 140.605 | Vertical | Pass |
| 20.0MHz Band QPSK | 1/#Mid | 1860 | -2.95 | 3.81 | 28.35 | 21.59 | 144.212 | Vertical | Pass |
| | | 1880 | -2.66 | 3.96 | 28.22 | 21.60 | 144.544 | Vertical | Pass |
| | | 1900 | -3.21 | 4.00 | 28.16 | 20.95 | 124.451 | Vertical | Pass |

| Radiated Power (EIRP) for Band 2 | | | | | | | | | |
|----------------------------------|---------------|-----------|-------------------|------------------------|---------------------------|------------------|-----------------|--------------------------------|------------|
| Mode | RB/RB SIZE | Frequency | Result | | | | | Polarization Of Max. ERP | Conclusion |
| | | | SG Level (dBm) | Cable Loss (dBm) | Antenna Factor (dB) | Max. EIRP | Max. EIRP | | |
| | | | | | | Average (dBm) | Average (mW) | | |
| 1.4MHz Band 16 QAM | 1/#Mid | 1850.7 | -3.28 | 3.76 | 28.24 | 21.20 | 131.826 | Horizontal | Pass |
| | | 1880 | -3.29 | 3.91 | 28.22 | 21.02 | 126.474 | Horizontal | Pass |
| | | 1909.3 | -3.23 | 3.93 | 28.20 | 21.04 | 127.057 | Horizontal | Pass |
| 3.0MHz Band 16 QAM | 1/#Mid | 1851.5 | -3.07 | 3.77 | 28.23 | 21.39 | 137.721 | Horizontal | Pass |
| | | 1880 | -3.12 | 3.91 | 28.24 | 21.21 | 132.130 | Horizontal | Pass |
| | | 1908.5 | -3.05 | 3.94 | 28.25 | 21.26 | 133.660 | Horizontal | Pass |
| 5.0MHz Band 16 QAM | 1/#Mid | 1852.5 | -3.07 | 3.77 | 28.31 | 21.47 | 140.281 | Horizontal | Pass |
| | | 1880 | -3.18 | 3.91 | 28.22 | 21.13 | 129.718 | Horizontal | Pass |
| | | 1907.5 | -2.19 | 3.94 | 28.20 | 22.07 | 161.065 | Horizontal | Pass |
| 10.0MHz Band 16 QAM | 1/#Mid | 1855 | -2.91 | 3.79 | 28.33 | 21.63 | 145.546 | Horizontal | Pass |
| | | 1880 | -2.72 | 3.95 | 28.22 | 21.55 | 142.889 | Horizontal | Pass |
| | | 1905 | -2.19 | 3.97 | 28.19 | 22.03 | 159.588 | Horizontal | Pass |
| 15.0MHz Band 16 QAM | 1/#Mid | 1857.5 | -2.71 | 3.79 | 28.34 | 21.84 | 152.757 | Horizontal | Pass |
| | | 1880 | -2.85 | 3.95 | 28.22 | 21.42 | 138.676 | Horizontal | Pass |
| | | 1902.5 | -2.94 | 3.97 | 28.18 | 21.27 | 133.968 | Horizontal | Pass |
| 20.0MHz Band 16 QAM | 1/#Mid | 1860 | -2.40 | 3.81 | 28.35 | 22.14 | 163.682 | Horizontal | Pass |
| | | 1880 | -2.25 | 3.96 | 28.22 | 22.01 | 158.855 | Horizontal | Pass |
| | | 1900 | -2.78 | 4.00 | 28.16 | 21.38 | 137.404 | Horizontal | Pass |
| 1.4MHz Band 16 QAM | 1/#Mid | 1850.7 | -4.13 | 3.76 | 28.24 | 20.35 | 108.393 | Vertical | Pass |
| | | 1880 | -4.75 | 3.91 | 28.22 | 19.56 | 90.365 | Vertical | Pass |
| | | 1909.3 | -4.65 | 3.93 | 28.20 | 19.62 | 91.622 | Vertical | Pass |
| 3.0MHz Band 16 QAM | 1/#Mid | 1851.5 | -3.54 | 3.77 | 28.23 | 20.92 | 123.595 | Vertical | Pass |
| | | 1880 | -4.68 | 3.91 | 28.24 | 19.65 | 92.257 | Vertical | Pass |
| | | 1908.5 | -4.17 | 3.94 | 28.25 | 20.14 | 103.276 | Vertical | Pass |
| 5.0MHz Band 16 QAM | 1/#Mid | 1852.5 | -4.39 | 3.77 | 28.31 | 20.15 | 103.514 | Vertical | Pass |
| | | 1880 | -4.34 | 3.91 | 28.22 | 19.97 | 99.312 | Vertical | Pass |
| | | 1907.5 | -3.67 | 3.94 | 28.20 | 20.59 | 114.551 | Vertical | Pass |

| | | | | | | | | | |
|---------|--------|--------|-------|------|-------|-------|---------|----------|------|
| 10.0MHz | 1/#Mid | 1855 | -3.83 | 3.79 | 28.33 | 20.71 | 117.761 | Vertical | Pass |
| Band 16 | | 1880 | -4.21 | 3.95 | 28.22 | 20.06 | 101.391 | Vertical | Pass |
| QAM | | 1905 | -4.45 | 3.97 | 28.19 | 19.77 | 94.842 | Vertical | Pass |
| 15.0MHz | 1/#Mid | 1857.5 | -3.57 | 3.79 | 28.34 | 20.98 | 125.314 | Vertical | Pass |
| Band 16 | | 1880 | -4.20 | 3.95 | 28.22 | 20.07 | 101.625 | Vertical | Pass |
| QAM | | 1902.5 | -4.04 | 3.97 | 28.18 | 20.17 | 103.992 | Vertical | Pass |
| 20.0MHz | 1/#Mid | 1860 | -3.76 | 3.81 | 28.35 | 20.78 | 119.674 | Vertical | Pass |
| Band 16 | | 1880 | -3.39 | 3.96 | 28.22 | 20.87 | 122.180 | Vertical | Pass |
| QAM | | 1900 | -3.93 | 4.00 | 28.16 | 20.23 | 105.439 | Vertical | Pass |

Note:

SG Level= Signal generator output

Max. EIRP Average (dBm)= Antenna Gain(dB)+ SG Level (dBm)- Cable Loss(dBm)

Factor Gain(dB)=Antenna Gain(dB) + Amplifier Factor (dB)

8.3 LTE BAND 4

| Radiated Power (EIRP) for Band 4 | | | | | | | | | |
|----------------------------------|------------|-----------|----------------|------------------|---------------------|-------------------------|------------------------|--------------------------|------------|
| Mode | RB/RB SIZE | Frequency | Result | | | | | | Conclusion |
| | | | SG Level (dBm) | Cable Loss (dBm) | Antenna Factor (dB) | Max. EIRP Average (dBm) | Max. EIRP Average (mW) | Polarization Of Max. ERP | |
| 1.4MHz Band QPSK | 1/#Mid | 1710.7 | 1.82 | 3.12 | 27.58 | 26.28 | 424.620 | Horizontal | Pass |
| | | 1732.5 | -1.90 | 3.27 | 27.61 | 22.44 | 175.388 | Horizontal | Pass |
| | | 1754.3 | -2.63 | 3.29 | 27.63 | 21.71 | 148.252 | Horizontal | Pass |
| 3.0MHz Band QPSK | 1/#Mid | 1711.5 | -2.36 | 3.13 | 27.61 | 22.12 | 162.930 | Horizontal | Pass |
| | | 1732.5 | -1.92 | 3.27 | 27.61 | 22.42 | 174.582 | Horizontal | Pass |
| | | 1753.5 | -2.56 | 3.30 | 27.62 | 21.76 | 149.968 | Horizontal | Pass |
| 5.0MHz Band QPSK | 1/#Mid | 1712.5 | -2.01 | 3.13 | 27.63 | 22.49 | 177.419 | Horizontal | Pass |
| | | 1732.5 | -1.85 | 3.27 | 27.61 | 22.49 | 177.419 | Horizontal | Pass |
| | | 1752.5 | -2.19 | 3.30 | 27.60 | 22.11 | 162.555 | Horizontal | Pass |
| 10.0MHz Band QPSK | 1/#Mid | 1715 | -2.47 | 3.15 | 27.64 | 22.02 | 159.221 | Horizontal | Pass |
| | | 1732.5 | -2.25 | 3.31 | 27.61 | 22.05 | 160.325 | Horizontal | Pass |
| | | 1750 | -2.21 | 3.33 | 27.59 | 22.05 | 160.325 | Horizontal | Pass |
| 15.0MHz Band QPSK | 1/#Mid | 1717.5 | -2.47 | 3.15 | 27.65 | 22.03 | 159.588 | Horizontal | Pass |
| | | 1732.5 | -2.28 | 3.31 | 27.61 | 22.02 | 159.221 | Horizontal | Pass |
| | | 1747.5 | -1.40 | 3.33 | 27.57 | 22.84 | 192.309 | Horizontal | Pass |
| 20.0MHz Band QPSK | 1/#Mid | 1720 | -2.15 | 3.17 | 27.66 | 22.34 | 171.396 | Horizontal | Pass |
| | | 1732.5 | -1.93 | 3.32 | 27.61 | 22.36 | 172.187 | Horizontal | Pass |
| | | 1745 | -2.09 | 3.36 | 27.56 | 22.11 | 162.555 | Horizontal | Pass |
| 1.4MHz Band QPSK | 1/#Mid | 1710.7 | -3.63 | 3.12 | 27.58 | 20.83 | 121.060 | Vertical | Pass |
| | | 1732.5 | -3.10 | 3.27 | 27.61 | 21.24 | 133.045 | Vertical | Pass |
| | | 1754.3 | -2.21 | 3.29 | 27.63 | 22.13 | 163.305 | Vertical | Pass |
| 3.0MHz Band QPSK | 1/#Mid | 1711.5 | -2.44 | 3.13 | 27.61 | 22.04 | 159.956 | Vertical | Pass |
| | | 1732.5 | -2.45 | 3.27 | 27.61 | 21.89 | 154.525 | Vertical | Pass |
| | | 1753.5 | -2.36 | 3.30 | 27.62 | 21.96 | 157.036 | Vertical | Pass |
| 5.0MHz Band QPSK | 1/#Mid | 1712.5 | -3.36 | 3.13 | 27.63 | 21.14 | 130.017 | Vertical | Pass |
| | | 1732.5 | -3.30 | 3.27 | 27.61 | 21.04 | 127.057 | Vertical | Pass |
| | | 1752.5 | -2.77 | 3.30 | 27.60 | 21.53 | 142.233 | Vertical | Pass |
| 10.0MHz Band | 1/#Mid | 1715 | -2.51 | 3.15 | 27.64 | 21.98 | 157.761 | Vertical | Pass |
| | | 1732.5 | -2.39 | 3.31 | 27.61 | 21.91 | 155.239 | Vertical | Pass |

| | | | | | | | | | |
|---------|--------|--------|-------|------|-------|-------|---------|----------|------|
| QPSK | | 1750 | -3.32 | 3.33 | 27.59 | 20.94 | 124.165 | Vertical | Pass |
| 15.0MHz | 1/#Mid | 1717.5 | -2.33 | 3.15 | 27.65 | 22.17 | 164.816 | Vertical | Pass |
| Band | | 1732.5 | -3.50 | 3.31 | 27.61 | 20.80 | 120.226 | Vertical | Pass |
| QPSK | | 1747.5 | -3.36 | 3.33 | 27.57 | 20.88 | 122.462 | Vertical | Pass |
| 20.0MHz | 1/#Mid | 1720 | -3.25 | 3.17 | 27.66 | 21.24 | 133.045 | Vertical | Pass |
| Band | | 1732.5 | -2.93 | 3.32 | 27.61 | 21.36 | 136.773 | Vertical | Pass |
| QPSK | | 1745 | -3.18 | 3.36 | 27.56 | 21.02 | 126.474 | Vertical | Pass |

| Radiated Power (EIRP) for Band 4 | | | | | | | | | |
|----------------------------------|------------|-----------|----------------|------------------|---------------------|-------------------------|------------------------|--------------------------|------------|
| Mode | RB/RB SIZE | Frequency | Result | | | | | | Conclusion |
| | | | SG Level (dBm) | Cable Loss (dBm) | Antenna Factor (dB) | Max. EIRP Average (dBm) | Max. EIRP Average (mW) | Polarization Of Max. ERP | |
| 1.4MHz Band 16 QAM | 1/#Mid | 1710.7 | -2.91 | 3.12 | 27.58 | 21.55 | 142.889 | Horizontal | Pass |
| | | 1732.5 | -3.17 | 3.27 | 27.61 | 21.17 | 130.918 | Horizontal | Pass |
| | | 1754.3 | -2.77 | 3.29 | 27.63 | 21.57 | 143.549 | Horizontal | Pass |
| 3.0MHz Band 16 QAM | 1/#Mid | 1711.5 | -2.71 | 3.13 | 27.61 | 21.77 | 150.314 | Horizontal | Pass |
| | | 1732.5 | -3.24 | 3.27 | 27.61 | 21.10 | 128.825 | Horizontal | Pass |
| | | 1753.5 | -3.40 | 3.30 | 27.62 | 20.92 | 123.595 | Horizontal | Pass |
| 5.0MHz Band 16 QAM | 1/#Mid | 1712.5 | -3.08 | 3.13 | 27.63 | 21.42 | 138.676 | Horizontal | Pass |
| | | 1732.5 | -3.22 | 3.27 | 27.61 | 21.12 | 129.420 | Horizontal | Pass |
| | | 1752.5 | -2.09 | 3.30 | 27.60 | 22.21 | 166.341 | Horizontal | Pass |
| 10.0MHz Band 16 QAM | 1/#Mid | 1715 | -2.89 | 3.15 | 27.64 | 21.60 | 144.544 | Horizontal | Pass |
| | | 1732.5 | -2.87 | 3.31 | 27.61 | 21.43 | 138.995 | Horizontal | Pass |
| | | 1750 | -2.05 | 3.33 | 27.59 | 22.21 | 166.341 | Horizontal | Pass |
| 15.0MHz Band 16 QAM | 1/#Mid | 1717.5 | -3.15 | 3.15 | 27.65 | 21.35 | 136.458 | Horizontal | Pass |
| | | 1732.5 | -2.82 | 3.31 | 27.61 | 21.48 | 140.605 | Horizontal | Pass |
| | | 1747.5 | -2.90 | 3.33 | 27.57 | 21.34 | 136.144 | Horizontal | Pass |
| 20.0MHz Band 16 QAM | 1/#Mid | 1720 | -2.31 | 3.17 | 27.66 | 22.18 | 165.196 | Horizontal | Pass |
| | | 1732.5 | -2.97 | 3.32 | 27.61 | 21.32 | 135.519 | Horizontal | Pass |
| | | 1745 | -2.19 | 3.36 | 27.56 | 22.01 | 158.855 | Horizontal | Pass |
| 1.4MHz Band 16 QAM | 1/#Mid | 1710.7 | -4.37 | 3.12 | 27.58 | 20.09 | 102.094 | Vertical | Pass |
| | | 1732.5 | -3.47 | 3.27 | 27.61 | 20.87 | 122.180 | Vertical | Pass |
| | | 1754.3 | -3.49 | 3.29 | 27.63 | 20.85 | 121.619 | Vertical | Pass |
| 3.0MHz Band 16 QAM | 1/#Mid | 1711.5 | -4.48 | 3.13 | 27.61 | 20.00 | 100.000 | Vertical | Pass |
| | | 1732.5 | -3.81 | 3.27 | 27.61 | 20.53 | 112.980 | Vertical | Pass |
| | | 1753.5 | -3.88 | 3.30 | 27.62 | 20.44 | 110.662 | Vertical | Pass |
| 5.0MHz Band 16 | 1/#Mid | 1712.5 | -4.79 | 3.13 | 27.63 | 19.71 | 93.541 | Vertical | Pass |
| | | 1732.5 | -4.21 | 3.27 | 27.61 | 20.13 | 103.039 | Vertical | Pass |

| | | | | | | | | | |
|---------|--------|--------|-------|------|-------|-------|---------|----------|------|
| QAM | | 1752.5 | -4.41 | 3.30 | 27.60 | 19.89 | 97.499 | Vertical | Pass |
| 10.0MHz | 1/#Mid | 1715 | -3.82 | 3.15 | 27.64 | 20.67 | 116.681 | Vertical | Pass |
| Band 16 | | 1732.5 | -3.23 | 3.31 | 27.61 | 21.07 | 127.938 | Vertical | Pass |
| QAM | | 1750 | -4.20 | 3.33 | 27.59 | 20.06 | 101.391 | Vertical | Pass |
| 15.0MHz | 1/#Mid | 1717.5 | -4.24 | 3.15 | 27.65 | 20.26 | 106.170 | Vertical | Pass |
| Band 16 | | 1732.5 | -4.36 | 3.31 | 27.61 | 19.94 | 98.628 | Vertical | Pass |
| QAM | | 1747.5 | -3.24 | 3.33 | 27.57 | 21.00 | 125.893 | Vertical | Pass |
| 20.0MHz | 1/#Mid | 1720 | -3.75 | 3.17 | 27.66 | 20.74 | 118.577 | Vertical | Pass |
| Band 16 | | 1732.5 | -3.88 | 3.32 | 27.61 | 20.41 | 109.901 | Vertical | Pass |
| QAM | | 1745 | -3.27 | 3.36 | 27.56 | 20.93 | 123.880 | Vertical | Pass |

Note:

SG Level= Signal generator output

Max. EIRP Average (dBm)= Antenna Gain(dB)+ SG Level (dBm)- Cable Loss(dBm)

Factor Gain(dB)=Antenna Gain(dB) + Amplifier Factor (dB)

8.4 LTE BAND 5

| Radiated Power (ERP) for Band 5 | | | | | | | | | | |
|---------------------------------|------------|-----------|----------------|------------------|---------------------|-----------------|-------------------------|------------------------|--------------------------|------------|
| Mode | RB/RB SIZE | Frequency | Result | | | | | | | Conclusion |
| | | | SG Level (dBm) | Cable Loss (dBm) | Antenna Factor (dB) | Correction (dB) | Max. EIRP Average (dBm) | Max. EIRP Average (mW) | Polarization Of Max. ERP | |
| 1.4MHz Band QPSK | 3/#Mid | 824.7 | 7.12 | 2.01 | 19.68 | 2.15 | 22.64 | 183.654 | Horizontal | Pass |
| | | 836.5 | 6.90 | 2.01 | 19.77 | 2.15 | 22.51 | 178.238 | Horizontal | Pass |
| | | 848.3 | 7.17 | 2.02 | 19.82 | 2.15 | 22.82 | 191.426 | Horizontal | Pass |
| 3.0MHz Band QPSK | 1/#Mid | 825.5 | 6.93 | 2.01 | 19.70 | 2.15 | 22.47 | 176.604 | Horizontal | Pass |
| | | 836.5 | 6.96 | 2.01 | 19.77 | 2.15 | 22.57 | 180.717 | Horizontal | Pass |
| | | 847.5 | 6.85 | 2.02 | 19.81 | 2.15 | 22.49 | 177.419 | Horizontal | Pass |
| 5.0MHz Band QPSK | 1/#Mid | 826.5 | 7.54 | 2.01 | 19.71 | 2.15 | 23.09 | 203.704 | Horizontal | Pass |
| | | 836.5 | 7.19 | 2.01 | 19.77 | 2.15 | 22.80 | 190.546 | Horizontal | Pass |
| | | 846.5 | 6.88 | 2.02 | 19.79 | 2.15 | 22.50 | 177.828 | Horizontal | Pass |
| 10.0MHz Band QPSK | 1/#Mid | 829 | 7.11 | 2.01 | 19.73 | 2.15 | 22.68 | 185.353 | Horizontal | Pass |
| | | 836.5 | 7.32 | 2.01 | 19.77 | 2.15 | 22.93 | 196.336 | Horizontal | Pass |
| | | 844 | 6.97 | 2.02 | 19.78 | 2.15 | 22.58 | 181.134 | Horizontal | Pass |
| 1.4MHz Band QPSK | 1/#Mid | 824.7 | 5.93 | 2.01 | 19.68 | 2.15 | 21.45 | 139.637 | Vertical | Pass |
| | | 836.5 | 5.69 | 2.01 | 19.77 | 2.15 | 21.30 | 134.896 | Vertical | Pass |
| | | 848.3 | 5.78 | 2.02 | 19.82 | 2.15 | 21.43 | 138.995 | Vertical | Pass |
| 3.0MHz Band QPSK | 1/#Mid | 825.5 | 5.93 | 2.01 | 19.70 | 2.15 | 21.47 | 140.281 | Vertical | Pass |
| | | 836.5 | 5.31 | 2.01 | 19.77 | 2.15 | 20.92 | 123.595 | Vertical | Pass |
| | | 847.5 | 5.50 | 2.02 | 19.81 | 2.15 | 21.14 | 130.017 | Vertical | Pass |
| 5.0MHz Band QPSK | 1/#Mid | 826.5 | 5.98 | 2.01 | 19.71 | 2.15 | 21.53 | 142.233 | Vertical | Pass |
| | | 836.5 | 6.59 | 2.01 | 19.77 | 2.15 | 22.20 | 165.959 | Vertical | Pass |
| | | 846.5 | 5.58 | 2.02 | 19.79 | 2.15 | 21.20 | 131.826 | Vertical | Pass |
| 10.0MHz Band QPSK | 1/#Mid | 829 | 5.06 | 2.01 | 19.73 | 2.15 | 20.63 | 115.611 | Vertical | Pass |
| | | 836.5 | 5.25 | 2.01 | 19.77 | 2.15 | 20.86 | 121.899 | Vertical | Pass |
| | | 844 | 6.05 | 2.02 | 19.78 | 2.15 | 21.66 | 146.555 | Vertical | Pass |

| Radiated Power (ERP) for Band 5 | | | | | | | | | | |
|---------------------------------|------------|-----------|----------------|------------------|---------------------|-----------------|-------------------------|------------------------|--------------------------|------------|
| Mode | RB/RB SIZE | Frequency | Result | | | | | | | Conclusion |
| | | | SG Level (dBm) | Cable Loss (dBm) | Antenna Factor (dB) | Correction (dB) | Max. EIRP Average (dBm) | Max. EIRP Average (mW) | Polarization Of Max. ERP | |
| 1.4MHz Band 16 QAM | 3/#Mid | 824.7 | 6.31 | 2.01 | 19.68 | 2.15 | 21.83 | 152.405 | Horizontal | Pass |
| | | 836.5 | 6.33 | 2.01 | 19.77 | 2.15 | 21.94 | 156.315 | Horizontal | Pass |
| | | 848.3 | 5.70 | 2.02 | 19.82 | 2.15 | 21.35 | 136.458 | Horizontal | Pass |
| 3.0MHz Band 16 QAM | 1/#Mid | 825.5 | 6.58 | 2.01 | 19.70 | 2.15 | 22.12 | 162.930 | Horizontal | Pass |
| | | 836.5 | 5.72 | 2.01 | 19.77 | 2.15 | 21.33 | 135.831 | Horizontal | Pass |
| | | 847.5 | 5.09 | 2.02 | 19.81 | 2.15 | 20.73 | 118.304 | Horizontal | Pass |
| 5.0MHz Band 16 QAM | 1/#Mid | 826.5 | 6.91 | 2.01 | 19.71 | 2.15 | 22.46 | 176.198 | Horizontal | Pass |
| | | 836.5 | 6.89 | 2.01 | 19.77 | 2.15 | 22.50 | 177.828 | Horizontal | Pass |
| | | 846.5 | 6.53 | 2.02 | 19.79 | 2.15 | 22.15 | 164.059 | Horizontal | Pass |
| 10.0MHz Band 16 QAM | 1/#Mid | 829 | 6.93 | 2.01 | 19.73 | 2.15 | 22.50 | 177.828 | Horizontal | Pass |
| | | 836.5 | 6.10 | 2.01 | 19.77 | 2.15 | 21.71 | 148.252 | Horizontal | Pass |
| | | 844 | 6.28 | 2.02 | 19.78 | 2.15 | 21.89 | 154.525 | Horizontal | Pass |
| 1.4MHz Band 16 QAM | 1/#Mid | 824.7 | 4.48 | 2.01 | 19.68 | 2.15 | 20.00 | 100.000 | Vertical | Pass |
| | | 836.5 | 5.80 | 2.01 | 19.77 | 2.15 | 21.41 | 138.357 | Vertical | Pass |
| | | 848.3 | 5.42 | 2.02 | 19.82 | 2.15 | 21.07 | 127.938 | Vertical | Pass |
| 3.0MHz Band 16 QAM | 1/#Mid | 825.5 | 5.77 | 2.01 | 19.70 | 2.15 | 21.31 | 135.207 | Vertical | Pass |
| | | 836.5 | 5.26 | 2.01 | 19.77 | 2.15 | 20.87 | 122.180 | Vertical | Pass |
| | | 847.5 | 6.36 | 2.02 | 19.81 | 2.15 | 22.00 | 158.489 | Vertical | Pass |
| 5.0MHz Band 16 QAM | 1/#Mid | 826.5 | 6.13 | 2.01 | 19.71 | 2.15 | 21.68 | 147.231 | Vertical | Pass |
| | | 836.5 | 5.19 | 2.01 | 19.77 | 2.15 | 20.80 | 120.226 | Vertical | Pass |
| | | 846.5 | 5.84 | 2.02 | 19.79 | 2.15 | 21.46 | 139.959 | Vertical | Pass |
| 10.0MHz Band 16 QAM | 1/#Mid | 829 | 4.42 | 2.01 | 19.73 | 2.15 | 19.99 | 99.770 | Vertical | Pass |
| | | 836.5 | 5.34 | 2.01 | 19.77 | 2.15 | 20.95 | 124.451 | Vertical | Pass |
| | | 844 | 6.03 | 2.02 | 19.78 | 2.15 | 21.64 | 145.881 | Vertical | Pass |

Note:

SG Level= Signal generator output

Max. EIRP Average (dBm)= Antenna Gain(dB)+ SG Level (dBm)- Cable Loss(dBm)

Factor Gain(dB)=Antenna Gain(dB) + Amplifier Factor (dB)

ERP(dBm)=EIRP-2.15

8.5 LTE BAND 7

| Radiated Power (EIRP) for Band 7 | | | | | | | | | |
|----------------------------------|------------|-----------|----------------|------------------|---------------------|-------------------------|------------------------|--------------------------|------------|
| Mode | RB/RB SIZE | Frequency | Result | | | | | | Conclusion |
| | | | SG Level (dBm) | Cable Loss (dBm) | Antenna Factor (dB) | Max. EIRP Average (dBm) | Max. EIRP Average (mW) | Polarization Of Max. ERP | |
| 5.0MHz Band QPSK | 1/#Mid | 2502.5 | -0.13 | 4.54 | 27.75 | 23.08 | 203.236 | Horizontal | Pass |
| | | 2535 | -0.30 | 4.69 | 27.72 | 22.73 | 187.499 | Horizontal | Pass |
| | | 2567.5 | -0.16 | 4.71 | 27.71 | 22.84 | 192.309 | Horizontal | Pass |
| 10.0MHz Band QPSK | 1/#Mid | 2505 | -0.77 | 4.55 | 27.76 | 22.44 | 175.388 | Horizontal | Pass |
| | | 2535 | -0.16 | 4.69 | 27.72 | 22.87 | 193.642 | Horizontal | Pass |
| | | 2565 | -0.53 | 4.72 | 27.70 | 22.45 | 175.792 | Horizontal | Pass |
| 15.0MHz Band QPSK | 1/#Mid | 2507.5 | -0.50 | 4.55 | 27.77 | 22.72 | 187.068 | Horizontal | Pass |
| | | 2535 | -0.04 | 4.69 | 27.72 | 22.99 | 199.067 | Horizontal | Pass |
| | | 2562.5 | -0.11 | 4.72 | 27.69 | 22.86 | 193.197 | Horizontal | Pass |
| 20.0MHz Band QPSK | 1/#Mid | 2510 | -0.15 | 4.57 | 27.78 | 23.06 | 202.302 | Horizontal | Pass |
| | | 2535 | -0.04 | 4.73 | 27.72 | 22.95 | 197.242 | Horizontal | Pass |
| | | 2560 | -0.53 | 4.75 | 27.68 | 22.40 | 173.780 | Horizontal | Pass |
| 5.0MHz Band QPSK | 1/#Mid | 2502.5 | -1.84 | 4.54 | 27.75 | 21.37 | 137.088 | Vertical | Pass |
| | | 2535 | -1.21 | 4.69 | 27.72 | 21.82 | 152.055 | Vertical | Pass |
| | | 2567.5 | -1.53 | 4.71 | 27.71 | 21.47 | 140.281 | Vertical | Pass |
| 10.0MHz Band QPSK | 1/#Mid | 2505 | -2.41 | 4.55 | 27.76 | 20.80 | 120.226 | Vertical | Pass |
| | | 2535 | -1.84 | 4.69 | 27.72 | 21.19 | 131.522 | Vertical | Pass |
| | | 2565 | -1.41 | 4.72 | 27.70 | 21.57 | 143.549 | Vertical | Pass |
| 15.0MHz Band QPSK | 1/#Mid | 2507.5 | -1.39 | 4.55 | 27.77 | 21.83 | 152.405 | Vertical | Pass |
| | | 2535 | -1.36 | 4.69 | 27.72 | 21.67 | 146.893 | Vertical | Pass |
| | | 2562.5 | -1.51 | 4.72 | 27.69 | 21.46 | 139.959 | Vertical | Pass |
| 20.0MHz Band QPSK | 1/#Mid | 2510 | -1.29 | 4.57 | 27.78 | 21.92 | 155.597 | Vertical | Pass |
| | | 2535 | -1.08 | 4.73 | 27.72 | 21.91 | 155.239 | Vertical | Pass |
| | | 2560 | -1.17 | 4.75 | 27.68 | 21.76 | 149.968 | Vertical | Pass |

| Radiated Power (EIRP) for Band 7 | | | | | | | | | |
|----------------------------------|------------|-----------|----------------|------------------|---------------------|-------------------------|------------------------|--------------------------|------------|
| Mode | RB/RB SIZE | Frequency | Result | | | | | | Conclusion |
| | | | SG Level (dBm) | Cable Loss (dBm) | Antenna Factor (dB) | Max. EIRP Average (dBm) | Max. EIRP Average (mW) | Polarization Of Max. ERP | |
| 5.0MHz Band 16 QAM | 1/#Mid | 2502.5 | -1.54 | 4.54 | 27.75 | 21.67 | 146.893 | Horizontal | Pass |
| | | 2535 | -0.98 | 4.69 | 27.72 | 22.05 | 160.325 | Horizontal | Pass |
| | | 2567.5 | -1.18 | 4.71 | 27.71 | 21.82 | 152.055 | Horizontal | Pass |
| 10.0MHz Band 16 QAM | 1/#Mid | 2505 | -0.95 | 4.55 | 27.76 | 22.26 | 168.267 | Horizontal | Pass |
| | | 2535 | -0.69 | 4.69 | 27.72 | 22.34 | 171.396 | Horizontal | Pass |
| | | 2565 | -1.79 | 4.72 | 27.70 | 21.19 | 131.522 | Horizontal | Pass |
| 15.0MHz Band 16 QAM | 1/#Mid | 2507.5 | -1.73 | 4.55 | 27.77 | 21.49 | 140.929 | Horizontal | Pass |
| | | 2535 | -1.41 | 4.69 | 27.72 | 21.62 | 145.211 | Horizontal | Pass |
| | | 2562.5 | -0.54 | 4.72 | 27.69 | 22.43 | 174.985 | Horizontal | Pass |
| 20.0MHz Band 16 QAM | 1/#Mid | 2510 | -1.58 | 4.57 | 27.78 | 21.63 | 145.546 | Horizontal | Pass |
| | | 2535 | -0.36 | 4.73 | 27.72 | 22.63 | 183.231 | Horizontal | Pass |
| | | 2560 | -0.99 | 4.75 | 27.68 | 21.94 | 156.315 | Horizontal | Pass |
| 5.0MHz Band 16 QAM | 1/#Mid | 2502.5 | -1.54 | 4.54 | 27.75 | 21.67 | 146.893 | Vertical | Pass |
| | | 2535 | -2.80 | 4.69 | 27.72 | 20.23 | 105.439 | Vertical | Pass |
| | | 2567.5 | -2.74 | 4.71 | 27.71 | 20.26 | 106.170 | Vertical | Pass |
| 10.0MHz Band 16 QAM | 1/#Mid | 2505 | -2.09 | 4.55 | 27.76 | 21.12 | 129.420 | Vertical | Pass |
| | | 2535 | -1.36 | 4.69 | 27.72 | 21.67 | 146.893 | Vertical | Pass |
| | | 2565 | -1.69 | 4.72 | 27.70 | 21.29 | 134.586 | Vertical | Pass |
| 15.0MHz Band 16 QAM | 1/#Mid | 2507.5 | -1.37 | 4.55 | 27.77 | 21.85 | 153.109 | Vertical | Pass |
| | | 2535 | -2.38 | 4.69 | 27.72 | 20.65 | 116.145 | Vertical | Pass |
| | | 2562.5 | -2.14 | 4.72 | 27.69 | 20.83 | 121.060 | Vertical | Pass |
| 20.0MHz Band 16 QAM | 1/#Mid | 2510 | -3.27 | 4.57 | 27.78 | 19.94 | 98.628 | Vertical | Pass |
| | | 2535 | -2.08 | 4.73 | 27.72 | 20.91 | 123.310 | Vertical | Pass |
| | | 2560 | -1.39 | 4.75 | 27.68 | 21.54 | 142.561 | Vertical | Pass |

Note:

SG Level= Signal generator output

Max. EIRP Average (dBm)= Antenna Factor (dB)+ SG Level (dBm)- Cable Loss(dBm)

8.6 LTE BAND 12

| Radiated Power (ERP) for Band 12 | | | | | | | | | | |
|----------------------------------|------------|-----------|----------------|------------------|---------------------|-----------------|-------------------------|------------------------|--------------------------|------------|
| Mode | RB/RB SIZE | Frequency | Result | | | | | | | Conclusion |
| | | | SG Level (dBm) | Cable Loss (dBm) | Antenna Factor (dB) | Correction (dB) | Max. EIRP Average (dBm) | Max. EIRP Average (mW) | Polarization Of Max. ERP | |
| 1.4MHz Band QPSK | 1/#Mid | 699.7 | 7.17 | 1.91 | 19.21 | 2.15 | 22.32 | 170.608 | Vertical | Pass |
| | | 707.5 | 7.73 | 1.91 | 19.26 | 2.15 | 22.93 | 196.336 | Vertical | Pass |
| | | 715.3 | 7.07 | 1.93 | 19.34 | 2.15 | 22.33 | 171.002 | Vertical | Pass |
| 3.0MHz Band QPSK | 1/#Mid | 700.5 | 7.01 | 1.91 | 19.21 | 2.15 | 22.16 | 164.437 | Vertical | Pass |
| | | 707.5 | 7.36 | 1.91 | 19.26 | 2.15 | 22.56 | 180.302 | Vertical | Pass |
| | | 714.5 | 7.21 | 1.93 | 19.34 | 2.15 | 22.47 | 176.604 | Vertical | Pass |
| 5.0MHz Band QPSK | 1/#Mid | 701.5 | 7.26 | 1.91 | 19.23 | 2.15 | 22.43 | 174.985 | Vertical | Pass |
| | | 707.5 | 6.98 | 1.91 | 19.26 | 2.15 | 22.18 | 165.196 | Vertical | Pass |
| | | 713.5 | 6.91 | 1.92 | 19.33 | 2.15 | 22.17 | 164.816 | Vertical | Pass |
| 10.0MHz Band QPSK | 1/#Mid | 704 | 7.48 | 1.91 | 19.25 | 2.15 | 22.67 | 184.927 | Vertical | Pass |
| | | 707.5 | 7.17 | 1.91 | 19.26 | 2.15 | 22.37 | 172.584 | Vertical | Pass |
| | | 711 | 7.59 | 1.92 | 19.32 | 2.15 | 22.84 | 192.309 | Vertical | Pass |
| 1.4MHz Band QPSK | 1/#Mid | 699.7 | 6.05 | 1.91 | 19.21 | 2.15 | 21.20 | 131.826 | Horizontal | Pass |
| | | 707.5 | 6.45 | 1.91 | 19.26 | 2.15 | 21.65 | 146.218 | Horizontal | Pass |
| | | 715.3 | 5.22 | 1.93 | 19.34 | 2.15 | 20.48 | 111.686 | Horizontal | Pass |
| 3.0MHz Band QPSK | 1/#Mid | 700.5 | 6.68 | 1.91 | 19.21 | 2.15 | 21.83 | 152.405 | Horizontal | Pass |
| | | 707.5 | 5.97 | 1.91 | 19.26 | 2.15 | 21.17 | 130.918 | Horizontal | Pass |
| | | 714.5 | 5.46 | 1.93 | 19.34 | 2.15 | 20.72 | 118.032 | Horizontal | Pass |
| 5.0MHz Band QPSK | 1/#Mid | 701.5 | 6.68 | 1.91 | 19.23 | 2.15 | 21.85 | 153.109 | Horizontal | Pass |
| | | 707.5 | 6.03 | 1.91 | 19.26 | 2.15 | 21.23 | 132.739 | Horizontal | Pass |
| | | 713.5 | 6.79 | 1.92 | 19.33 | 2.15 | 22.05 | 160.325 | Horizontal | Pass |
| 10.0MHz Band QPSK | 1/#Mid | 704 | 5.43 | 1.91 | 19.25 | 2.15 | 20.62 | 115.345 | Horizontal | Pass |
| | | 707.5 | 5.78 | 1.91 | 19.26 | 2.15 | 20.98 | 125.314 | Horizontal | Pass |
| | | 711 | 6.20 | 1.92 | 19.32 | 2.15 | 21.45 | 139.637 | Horizontal | Pass |

| Radiated Power (ERP) for Band 12 | | | | | | | | | | |
|----------------------------------|------------|-----------|----------|------------------|---------------------|------------|--------------|-----------|--------------------------|------------|
| Mode | RB/RB SIZE | Frequency | Result | | | | | | | Conclusion |
| | | | SG Level | Cable Loss (dBm) | Antenna Factor (dB) | Correction | Max. EIRP | Max. EIRP | Polarization Of Max. ERP | |
| | | | (dBm) | | | (dB) | Average | Average | | |
| | | | | | | | (dBm) | (mW) | | |
| 1.4MHz Band 16 QAM | 1/#Mid | 699.7 | 7.02 | 1.91 | 19.21 | 2.15 | 22.17 | 164.816 | Vertical | Pass |
| | | 707.5 | 6.87 | 1.91 | 19.26 | 2.15 | 22.07 | 161.065 | Vertical | Pass |
| | | 715.3 | 6.70 | 1.93 | 19.34 | 2.15 | 21.96 | 157.036 | Vertical | Pass |
| 3.0MHz Band 16 QAM | 1/#Mid | 700.5 | 6.78 | 1.91 | 19.21 | 2.15 | 21.93 | 155.955 | Vertical | Pass |
| | | 707.5 | 6.82 | 1.91 | 19.26 | 2.15 | 22.02 | 159.221 | Vertical | Pass |
| | | 714.5 | 6.53 | 1.93 | 19.34 | 2.15 | 21.79 | 151.008 | Vertical | Pass |
| 5.0MHz Band 16 QAM | 1/#Mid | 701.5 | 7.30 | 1.91 | 19.23 | 2.15 | 22.47 | 176.604 | Vertical | Pass |
| | | 707.5 | 7.05 | 1.91 | 19.26 | 2.15 | 22.25 | 167.880 | Vertical | Pass |
| | | 713.5 | 6.96 | 1.92 | 19.33 | 2.15 | 22.22 | 166.725 | Vertical | Pass |
| 10.0MHz Band 16 QAM | 1/#Mid | 704 | 7.54 | 1.91 | 19.25 | 2.15 | 22.73 | 187.499 | Vertical | Pass |
| | | 707.5 | 7.90 | 1.91 | 19.26 | 2.15 | 23.10 | 204.174 | Vertical | Pass |
| | | 711 | 6.94 | 1.92 | 19.32 | 2.15 | 22.19 | 165.577 | Vertical | Pass |
| 1.4MHz Band 16 QAM | 1/#Mid | 699.7 | 6.27 | 1.91 | 19.21 | 2.15 | 21.42 | 138.676 | Horizontal | Pass |
| | | 707.5 | 6.84 | 1.91 | 19.26 | 2.15 | 22.04 | 159.956 | Horizontal | Pass |
| | | 715.3 | 6.38 | 1.93 | 19.34 | 2.15 | 21.64 | 145.881 | Horizontal | Pass |
| 3.0MHz Band 16 QAM | 1/#Mid | 700.5 | 6.73 | 1.91 | 19.21 | 2.15 | 21.88 | 154.170 | Horizontal | Pass |
| | | 707.5 | 5.86 | 1.91 | 19.26 | 2.15 | 21.06 | 127.644 | Horizontal | Pass |
| | | 714.5 | 6.20 | 1.93 | 19.34 | 2.15 | 21.46 | 139.959 | Horizontal | Pass |
| 5.0MHz Band 16 QAM | 1/#Mid | 701.5 | 6.89 | 1.91 | 19.23 | 2.15 | 22.06 | 160.694 | Horizontal | Pass |
| | | 707.5 | 6.84 | 1.91 | 19.26 | 2.15 | 22.04 | 159.956 | Horizontal | Pass |
| | | 713.5 | 6.62 | 1.92 | 19.33 | 2.15 | 21.88 | 154.170 | Horizontal | Pass |
| 10.0MHz Band 16 QAM | 1/#Mid | 704 | 5.32 | 1.91 | 19.25 | 2.15 | 20.51 | 112.460 | Horizontal | Pass |
| | | 707.5 | 6.45 | 1.91 | 19.26 | 2.15 | 21.65 | 146.218 | Horizontal | Pass |
| | | 711 | 5.85 | 1.92 | 19.32 | 2.15 | 21.10 | 128.825 | Horizontal | Pass |

Note:

SG Level= Signal generator output

Max. EIRP Average (dBm)= Antenna Gain(dB)+ SG Level (dBm)- Cable Loss(dBm)

Factor Gain(dB)=Antenna Gain(dB) + Amplifier Factor (dB)

ERP(dBm)=EIRP-2.15

8.7 LTE BAND 17

| Radiated Power (ERP) for Band 17 | | | | | | | | | | |
|----------------------------------|------------|-----------|----------------|------------------|---------------------|-----------------|-------------------------|------------------------|--------------------------|------------|
| Mode | RB/RB SIZE | Frequency | Result | | | | | | | Conclusion |
| | | | SG Level (dBm) | Cable Loss (dBm) | Antenna Factor (dB) | Correction (dB) | Max. EIRP Average (dBm) | Max. EIRP Average (mW) | Polarization Of Max. ERP | |
| 5.0MHz Band QPSK | 1/#Mid | 706.5 | 7.48 | 1.91 | 19.23 | 2.15 | 22.65 | 184.077 | Vertical | Pass |
| | | 710 | 8.08 | 1.91 | 19.26 | 2.15 | 23.28 | 212.814 | Vertical | Pass |
| | | 713.5 | 7.12 | 1.92 | 19.33 | 2.15 | 22.38 | 172.982 | Vertical | Pass |
| 10.0MHz Band QPSK | 1/#Mid | 709 | 7.48 | 1.91 | 19.25 | 2.15 | 22.67 | 184.927 | Vertical | Pass |
| | | 710 | 7.71 | 1.91 | 19.26 | 2.15 | 22.91 | 195.434 | Vertical | Pass |
| | | 711 | 7.90 | 1.92 | 19.32 | 2.15 | 23.15 | 206.538 | Vertical | Pass |
| 5.0MHz Band QPSK | 1/#Mid | 706.5 | 7.12 | 1.91 | 19.23 | 2.15 | 22.29 | 169.434 | Horizontal | Pass |
| | | 710 | 6.15 | 1.91 | 19.26 | 2.15 | 21.35 | 136.458 | Horizontal | Pass |
| | | 713.5 | 6.99 | 1.92 | 19.33 | 2.15 | 22.25 | 167.880 | Horizontal | Pass |
| 10.0MHz Band QPSK | 1/#Mid | 709 | 6.50 | 1.91 | 19.25 | 2.15 | 21.69 | 147.571 | Horizontal | Pass |
| | | 710 | 5.81 | 1.91 | 19.26 | 2.15 | 21.01 | 126.183 | Horizontal | Pass |
| | | 711 | 5.67 | 1.92 | 19.32 | 2.15 | 20.92 | 123.595 | Horizontal | Pass |

| Radiated Power (ERP) for Band 17 | | | | | | | | | | |
|----------------------------------|------------|-----------|----------------|------------------|---------------------|-----------------|-------------------------|------------------------|--------------------------|------------|
| Mode | RB/RB SIZE | Frequency | Result | | | | | | | Conclusion |
| | | | SG Level (dBm) | Cable Loss (dBm) | Antenna Factor (dB) | Correction (dB) | Max. EIRP Average (dBm) | Max. EIRP Average (mW) | Polarization Of Max. ERP | |
| 5.0MHz Band 16 QAM | 1/#Mid | 706.5 | 7.48 | 1.91 | 19.23 | 2.15 | 22.65 | 184.077 | Vertical | Pass |
| | | 710 | 7.44 | 1.91 | 19.26 | 2.15 | 22.64 | 183.654 | Vertical | Pass |
| | | 713.5 | 7.18 | 1.92 | 19.33 | 2.15 | 22.44 | 175.388 | Vertical | Pass |
| 10.0MHz Band 16 QAM | 1/#Mid | 709 | 6.46 | 1.91 | 19.25 | 2.15 | 21.65 | 146.218 | Vertical | Pass |
| | | 710 | 7.05 | 1.91 | 19.26 | 2.15 | 22.25 | 167.880 | Vertical | Pass |
| | | 711 | 6.65 | 1.92 | 19.32 | 2.15 | 21.90 | 154.882 | Vertical | Pass |
| 5.0MHz Band 16 QAM | 1/#Mid | 706.5 | 5.69 | 1.91 | 19.23 | 2.15 | 20.86 | 121.899 | Horizontal | Pass |
| | | 710 | 5.73 | 1.91 | 19.26 | 2.15 | 20.93 | 123.880 | Horizontal | Pass |
| | | 713.5 | 5.85 | 1.92 | 19.33 | 2.15 | 21.11 | 129.122 | Horizontal | Pass |
| 10.0MHz Band 16 QAM | 1/#Mid | 709 | 6.75 | 1.91 | 19.25 | 2.15 | 21.94 | 156.315 | Horizontal | Pass |
| | | 710 | 6.44 | 1.91 | 19.26 | 2.15 | 21.64 | 145.881 | Horizontal | Pass |
| | | 711 | 5.71 | 1.92 | 19.32 | 2.15 | 20.96 | 124.738 | Horizontal | Pass |

Note:

ERP=EIRP-2.15

SG Level= Signal generator output

Max. EIRP Average (dBm)= Antenna Factor (dB)+ SG Level (dBm)- Cable Loss(dBm)

8.8 LTE BAND 41

| Radiated Power (EIRP) for Band 41 | | | | | | | | | |
|-----------------------------------|------------|-----------|----------|------------------|---------------------|--------------|-----------|--------------------------|------------|
| Mode | RB/RB SIZE | Frequency | Result | | | | | | Conclusion |
| | | | SG Level | Cable Loss (dBm) | Antenna Factor (dB) | Max. EIRP | Max. EIRP | Polarization Of Max. ERP | |
| | | | (dBm) | | | Average | Average | | |
| | | | | | | (dBm) | (mW) | | |
| 5.0MHz Band QPSK | 1/#Mid | 2498.5 | -1.33 | 4.54 | 27.75 | 21.88 | 154.170 | Horizontal | Pass |
| | | 2593 | -0.80 | 4.69 | 27.72 | 22.23 | 167.109 | Horizontal | Pass |
| | | 2687.5 | -0.98 | 4.71 | 27.71 | 22.02 | 159.221 | Horizontal | Pass |
| 10.0MHz Band QPSK | 1/#Mid | 2501 | -1.57 | 4.55 | 27.76 | 21.64 | 145.881 | Horizontal | Pass |
| | | 2593 | -1.52 | 4.69 | 27.72 | 21.51 | 141.579 | Horizontal | Pass |
| | | 2685 | -1.24 | 4.72 | 27.70 | 21.74 | 149.279 | Horizontal | Pass |
| 15.0MHz Band QPSK | 1/#Mid | 2503.5 | -1.61 | 4.55 | 27.77 | 21.61 | 144.877 | Horizontal | Pass |
| | | 2593 | -1.23 | 4.69 | 27.72 | 21.80 | 151.356 | Horizontal | Pass |
| | | 2682.5 | -1.09 | 4.72 | 27.69 | 21.88 | 154.170 | Horizontal | Pass |
| 20.0MHz Band QPSK | 1/#Mid | 2506 | -1.39 | 4.57 | 27.78 | 21.82 | 152.055 | Horizontal | Pass |
| | | 2593 | -1.83 | 4.73 | 27.72 | 21.16 | 130.617 | Horizontal | Pass |
| | | 2680 | -1.75 | 4.75 | 27.68 | 21.18 | 131.220 | Horizontal | Pass |
| 5.0MHz Band QPSK | 1/#Mid | 2498.5 | -1.65 | 4.54 | 27.75 | 21.56 | 143.219 | Vertical | Pass |
| | | 2593 | -1.71 | 4.69 | 27.72 | 21.32 | 135.519 | Vertical | Pass |
| | | 2687.5 | -1.62 | 4.71 | 27.71 | 21.38 | 137.404 | Vertical | Pass |
| 10.0MHz Band QPSK | 1/#Mid | 2501 | -1.23 | 4.55 | 27.76 | 21.98 | 157.761 | Vertical | Pass |
| | | 2593 | -1.96 | 4.69 | 27.72 | 21.07 | 127.938 | Vertical | Pass |
| | | 2685 | -1.47 | 4.72 | 27.70 | 21.51 | 141.579 | Vertical | Pass |
| 15.0MHz Band QPSK | 1/#Mid | 2503.5 | -1.99 | 4.55 | 27.77 | 21.23 | 132.739 | Vertical | Pass |
| | | 2593 | -1.35 | 4.69 | 27.72 | 21.68 | 147.231 | Vertical | Pass |
| | | 2682.5 | -1.86 | 4.72 | 27.69 | 21.11 | 129.122 | Vertical | Pass |
| 20.0MHz Band QPSK | 1/#Mid | 2506 | -2.32 | 4.57 | 27.78 | 20.89 | 122.744 | Vertical | Pass |
| | | 2593 | -1.95 | 4.73 | 27.72 | 21.04 | 127.057 | Vertical | Pass |
| | | 2680 | -1.41 | 4.75 | 27.68 | 21.52 | 141.906 | Vertical | Pass |

| Radiated Power (EIRP) for Band 41 | | | | | | | | | |
|-----------------------------------|------------|-----------|----------|------------|----------------|--------------|-----------|--------------------------|------------|
| Mode | RB/RB SIZE | Frequency | Result | | | | | | Conclusion |
| | | | SG Level | Cable Loss | Antenna Factor | Max. EIRP | Max. EIRP | Polarization Of Max. ERP | |
| | | | (dBm) | | | Average | Average | | |
| | | | | (dBm) | (dB) | (dBm) | (mW) | | |
| 5.0MHz Band 16 QAM | 1/#Mid | 2498.5 | -1.04 | 4.54 | 27.75 | 22.17 | 164.816 | Horizontal | Pass |
| | | 2593 | -1.45 | 4.69 | 27.72 | 21.58 | 143.880 | Horizontal | Pass |
| | | 2687.5 | -1.08 | 4.71 | 27.71 | 21.92 | 155.597 | Horizontal | Pass |
| 10.0MHz Band 16 QAM | 1/#Mid | 2501 | -1.04 | 4.55 | 27.76 | 22.17 | 164.816 | Horizontal | Pass |
| | | 2593 | -1.37 | 4.69 | 27.72 | 21.66 | 146.555 | Horizontal | Pass |
| | | 2685 | -1.28 | 4.72 | 27.70 | 21.70 | 147.911 | Horizontal | Pass |
| 15.0MHz Band 16 QAM | 1/#Mid | 2503.5 | -1.23 | 4.55 | 27.77 | 21.99 | 158.125 | Horizontal | Pass |
| | | 2593 | -0.71 | 4.69 | 27.72 | 22.32 | 170.608 | Horizontal | Pass |
| | | 2682.5 | -1.27 | 4.72 | 27.69 | 21.70 | 147.911 | Horizontal | Pass |
| 20.0MHz Band 16 QAM | 1/#Mid | 2506 | -1.82 | 4.57 | 27.78 | 21.39 | 137.721 | Horizontal | Pass |
| | | 2593 | -1.67 | 4.73 | 27.72 | 21.32 | 135.519 | Horizontal | Pass |
| | | 2680 | -1.19 | 4.75 | 27.68 | 21.74 | 149.279 | Horizontal | Pass |
| 5.0MHz Band 16 QAM | 1/#Mid | 2498.5 | -1.38 | 4.54 | 27.75 | 21.83 | 152.405 | Vertical | Pass |
| | | 2593 | -1.05 | 4.69 | 27.72 | 21.98 | 157.761 | Vertical | Pass |
| | | 2687.5 | -1.69 | 4.71 | 27.71 | 21.31 | 135.207 | Vertical | Pass |
| 10.0MHz Band 16 QAM | 1/#Mid | 2501 | -1.80 | 4.55 | 27.76 | 21.41 | 138.357 | Vertical | Pass |
| | | 2593 | -1.97 | 4.69 | 27.72 | 21.06 | 127.644 | Vertical | Pass |
| | | 2685 | -1.65 | 4.72 | 27.70 | 21.33 | 135.831 | Vertical | Pass |
| 15.0MHz Band 16 QAM | 1/#Mid | 2503.5 | -1.61 | 4.55 | 27.77 | 21.61 | 144.877 | Vertical | Pass |
| | | 2593 | -1.85 | 4.69 | 27.72 | 21.18 | 131.220 | Vertical | Pass |
| | | 2682.5 | -1.75 | 4.72 | 27.69 | 21.22 | 132.434 | Vertical | Pass |
| 20.0MHz Band 16 QAM | 1/#Mid | 2506 | -1.88 | 4.57 | 27.78 | 21.33 | 135.831 | Vertical | Pass |
| | | 2593 | -1.66 | 4.73 | 27.72 | 21.33 | 135.831 | Vertical | Pass |
| | | 2680 | -2.51 | 4.75 | 27.68 | 20.42 | 110.154 | Vertical | Pass |

Note:

SG Level= Signal generator output

Max. EIRP Average (dBm)= Antenna Gain(dB)+ SG Level (dBm)- Cable Loss(dBm)

Factor Gain(dB)=Antenna Gain(dB) + Amplifier Factor (dB)

9. SPURIOUS RADIATION EMISSION

RULE PART(S)

FCC: §2.1053, §22.917, §24.238, §27.53 and §90.691

LIMIT

§22.917 (e) and §24.238 and §90.691 (a): Out of band emissions. The power of any emission outside of the authorized operating frequency ranges must be attenuated below the transmitting power (P) by a factor of at least $43 + 10 \log (P)$ dB.

§27.53 (g) For operations in the 698–746 MHz band, the power of any emission outside a licensee's frequency band(s) of operation shall be attenuated below the transmitter power (P) within the licensed band(s) of operation, measured in watts, by at least $43 + 10 \log (P)$ dB.

§27.53 (h) For operations in the 1710–1755 MHz and 2110–2155 MHz bands, the power of any emission outside a licensee's frequency block shall be attenuated below the transmitter power (P) by at least $43 + 10 \log_{10}(P)$ dB.

TEST PROCEDURE

For Cellular equipment - Compliance with these rules is based on the use of measurement instrumentation employing a resolution bandwidth of 100 kHz or greater. In the 1 MHz bands immediately outside and adjacent to the frequency block a resolution bandwidth of at least one percent of the emission bandwidth of the fundamental emission of the transmitter may be employed. A narrower resolution bandwidth is permitted in all cases to improve measurement accuracy provided the measured power is integrated over the full required measurement bandwidth (i.e. 100 kHz or 1 percent of emission bandwidth, as specified). The emission bandwidth is defined as the width of the signal between two points, one below the carrier center frequency and one above the carrier center frequency, outside of which all emissions are attenuated at least 26 dB below the transmitter power.

For PCS equipment - Compliance with these rules is based on the use of measurement instrumentation employing a resolution bandwidth of 1 MHz or greater. However, in the 1 MHz bands immediately outside and adjacent to the frequency block a resolution bandwidth of at least one percent of the emission bandwidth of the fundamental emission of the transmitter may be employed. A narrower resolution bandwidth is permitted in all cases to improve measurement accuracy provided the measured power is integrated over the full required measurement bandwidth (i.e. 1 MHz or 1 percent of emission bandwidth, as specified). The emission bandwidth is defined as the width of the signal between two points, one below the carrier center frequency and one above the carrier center frequency, outside of which all emissions are attenuated at least 26 dB below the transmitter power.

The unwanted emission power shall be measured with a resolution bandwidth of at least 1% of the occupied bandwidth in the 1 MHz band immediately outside and adjacent to the channel edge of the equipment. Beyond the 1 MHz band immediately outside the channel edge of the equipment, a resolution bandwidth of 1 MHz shall be employed. A narrower resolution bandwidth is allowed to be used provided that the measured power is integrated over the full required measurement bandwidth of 1 MHz or 1% of the occupied bandwidth as applicable.

The power of any unwanted emissions measured from the channel edge of the equipment shall be attenuated below the transmitter power, P (dBW), as follows:

- a. for base station and subscriber equipment, other than mobile subscriber equipment, the attenuation shall not be less than $43 + 10 \text{ Log}_{10}(p)$, dB; and
- b. for mobile subscriber equipment, the attenuation shall not be less than $43 + 10 \text{ Log}_{10}(p)$, dB at the channel edges and $55 + 10 \text{ Log}_{10}(p)$ at 5.5 MHz away and beyond the channel edges where p in (a) and (b) is the transmitter power measured in watts.

MODES TESTED

LTE Band 2/4/5/7/12/17/41

RESULTS

PASS

9.1 LTE BAND 2

QPSK EIRP POWER FOR LTE BAND 2 (1.4MHZ BANDWIDTH)

| Test Results for Low Channel 1850.7MHz | | | | | | | |
|---|---------------|----------------|--------------------|---------------------|-------------|-------------|------------|
| Frequency(MHz) | SG Level(dBm) | Cable Loss(dB) | Antenna Factor(dB) | Absolute Level(dBm) | Limit (dBm) | Margin(dBm) | Polarity |
| 3701.4 | -49.33 | 4.04 | 33.51 | -19.86 | -13 | -6.86 | Horizontal |
| 3701.4 | -51.70 | 4.04 | 33.51 | -22.23 | -13 | -9.23 | Vertical |
| 5552.1 | -45.75 | 5.24 | 35.84 | -15.15 | -13 | -2.15 | Vertical |
| 5552.1 | -50.78 | 5.24 | 35.84 | -20.18 | -13 | -7.18 | Horizontal |
| 185.1 | -39.42 | 1.43 | 16.02 | -24.83 | -13 | -11.83 | Vertical |
| 453.7 | -34.09 | 1.30 | 17.99 | -17.40 | -13 | -4.40 | Horizontal |
| Test Results for Mid Channel 1880MHz | | | | | | | |
| 3760.0 | -47.17 | 4.04 | 33.56 | -17.65 | -13 | -4.65 | Horizontal |
| 3760.0 | -51.65 | 4.04 | 33.56 | -22.13 | -13 | -9.13 | Vertical |
| 5640.0 | -48.61 | 5.24 | 35.91 | -17.94 | -13 | -4.94 | Vertical |
| 5640.0 | -50.19 | 5.24 | 35.91 | -19.52 | -13 | -6.52 | Horizontal |
| 183.5 | -36.02 | 1.62 | 16.97 | -20.67 | -13 | -7.67 | Vertical |
| 289.4 | -35.09 | 1.74 | 15.98 | -20.86 | -13 | -7.86 | Horizontal |
| Test Results for High Channel 1909.3MHz | | | | | | | |
| 3818.6 | -45.29 | 4.04 | 34.00 | -15.33 | -13 | -2.33 | Horizontal |
| 3818.6 | -46.64 | 4.04 | 34.00 | -16.68 | -13 | -3.68 | Vertical |
| 5727.9 | -50.81 | 5.24 | 36.04 | -20.01 | -13 | -7.01 | Vertical |
| 5727.9 | -48.19 | 5.24 | 36.04 | -17.39 | -13 | -4.39 | Horizontal |
| 193.8 | -41.31 | 1.42 | 17.29 | -25.44 | -13 | -12.44 | Vertical |
| 342.6 | -34.92 | 1.50 | 17.90 | -18.51 | -13 | -5.51 | Horizontal |

QPSK EIRP POWER FOR LTE BAND 2 (20.0MHZ BANDWIDTH)

| Test Results for Low Channel 1860MHz | | | | | | | |
|---------------------------------------|---------------|----------------|--------------------|---------------------|-------------|-------------|------------|
| Frequency(MHz) | SG Level(dBm) | Cable Loss(dB) | Antenna Factor(dB) | Absolute Level(dBm) | Limit (dBm) | Margin(dBm) | Polarity |
| 3720.0 | -42.95 | 4.07 | 33.54 | -13.48 | -13 | -0.48 | Horizontal |
| 3720.0 | -50.12 | 4.07 | 33.54 | -20.65 | -13 | -7.65 | Vertical |
| 5580.0 | -46.87 | 5.28 | 35.86 | -16.29 | -13 | -3.29 | Vertical |
| 5580.0 | -50.90 | 5.28 | 35.86 | -20.32 | -13 | -7.32 | Horizontal |
| 208.5 | -39.57 | 1.58 | 16.89 | -24.25 | -13 | -11.25 | Vertical |
| 357.0 | -42.33 | 1.76 | 17.26 | -26.83 | -13 | -13.83 | Horizontal |
| Test Results for Mid Channel 1880MHz | | | | | | | |
| 3760.0 | -46.58 | 4.04 | 33.56 | -17.06 | -13 | -4.06 | Horizontal |
| 3760.0 | -47.04 | 4.04 | 33.56 | -17.52 | -13 | -4.52 | Vertical |
| 5640.0 | -50.03 | 5.24 | 35.91 | -19.36 | -13 | -6.36 | Vertical |
| 5640.0 | -50.70 | 5.24 | 35.91 | -20.03 | -13 | -7.03 | Horizontal |
| 200.6 | -43.21 | 1.46 | 16.27 | -28.40 | -13 | -15.40 | Vertical |
| 344.7 | -40.15 | 1.59 | 15.15 | -26.59 | -13 | -13.59 | Horizontal |
| Test Results for High Channel 1900MHz | | | | | | | |
| 3800.0 | -48.76 | 4.04 | 34.00 | -18.80 | -13 | -5.80 | Horizontal |
| 3800.0 | -46.51 | 4.04 | 34.00 | -16.55 | -13 | -3.55 | Vertical |
| 5700.0 | -46.53 | 5.24 | 36.04 | -15.73 | -13 | -2.73 | Vertical |
| 5700.0 | -52.23 | 5.24 | 36.04 | -21.43 | -13 | -8.43 | Horizontal |
| 212.0 | -36.85 | 1.36 | 17.39 | -20.81 | -13 | -7.81 | Vertical |
| 312.7 | -42.32 | 1.66 | 15.39 | -28.59 | -13 | -15.59 | Horizontal |

Note: P_{Mea}(dBm)= Power(dBm)+ AR_{pl} (dBm)

. Over Limit= : P_{Mea}(dBm)-Limit(dBm)

. Both QPSK and 16QAM has been tested, the worst case is QPSK mode, the report just reported the worst case.

9.2 LTE BAND 4

QPSK EIRP POWER FOR LTE BAND 4 (1.4MHZ BANDWIDTH)

| Test Results for Low Channel 1710.7MHz | | | | | | | |
|---|---------------|----------------|--------------------|---------------------|-------------|-------------|------------|
| Frequency(MHz) | SG Level(dBm) | Cable Loss(dB) | Antenna Factor(dB) | Absolute Level(dBm) | Limit (dBm) | Margin(dBm) | Polarity |
| 3421.4 | -49.85 | 4.02 | 29.80 | -24.07 | -13 | -11.07 | Horizontal |
| 3421.4 | -48.31 | 4.02 | 29.80 | -22.53 | -13 | -9.53 | Vertical |
| 5132.1 | -51.10 | 5.24 | 35.84 | -20.50 | -13 | -7.50 | Vertical |
| 5132.1 | -50.94 | 5.24 | 35.84 | -20.34 | -13 | -7.34 | Horizontal |
| 197.8 | -41.50 | 1.68 | 16.04 | -27.14 | -13 | -14.14 | Vertical |
| 454.4 | -35.88 | 1.78 | 17.74 | -19.92 | -13 | -6.92 | Horizontal |
| Test Results for Mid Channel 1732.5MHz | | | | | | | |
| 3465.0 | -49.39 | 4.03 | 30.00 | -23.42 | -13 | -10.42 | Horizontal |
| 3465.0 | -43.99 | 4.03 | 30.00 | -18.02 | -13 | -5.02 | Vertical |
| 5197.5 | -45.76 | 5.25 | 35.86 | -15.15 | -13 | -2.15 | Vertical |
| 5197.5 | -48.16 | 5.25 | 35.86 | -17.55 | -13 | -4.55 | Horizontal |
| 207.5 | -42.82 | 1.72 | 17.69 | -26.85 | -13 | -13.85 | Vertical |
| 345.7 | -43.07 | 1.62 | 16.02 | -28.66 | -13 | -15.66 | Horizontal |
| Test Results for High Channel 1754.3MHz | | | | | | | |
| 3508.6 | -48.60 | 4.05 | 30.01 | -22.64 | -13 | -9.64 | Horizontal |
| 3508.6 | -46.44 | 4.05 | 30.01 | -20.48 | -13 | -7.48 | Vertical |
| 5262.9 | -49.45 | 5.26 | 35.86 | -18.85 | -13 | -5.85 | Vertical |
| 5262.9 | -49.91 | 5.26 | 35.86 | -19.31 | -13 | -6.31 | Horizontal |
| 182.9 | -32.39 | 1.80 | 16.69 | -17.50 | -13 | -4.50 | Vertical |
| 332.1 | -39.85 | 1.75 | 16.66 | -24.95 | -13 | -11.95 | Horizontal |

QPSK EIRP POWER FOR LTE BAND 4 (20.0MHZ BANDWIDTH)

| Test Results for Low Channel 1720MHz | | | | | | | |
|--|---------------|----------------|--------------------|---------------------|-------------|-------------|------------|
| Frequency(MHz) | SG Level(dBm) | Cable Loss(dB) | Antenna Factor(dB) | Absolute Level(dBm) | Limit (dBm) | Margin(dBm) | Polarity |
| 3440.0 | -49.07 | 4.02 | 29.80 | -23.29 | -13 | -10.29 | Horizontal |
| 3440.0 | -48.20 | 4.02 | 29.80 | -22.42 | -13 | -9.42 | Vertical |
| 5160.0 | -52.84 | 5.24 | 35.84 | -22.24 | -13 | -9.24 | Vertical |
| 5160.0 | -50.29 | 5.24 | 35.84 | -19.69 | -13 | -6.69 | Horizontal |
| 182.5 | -39.58 | 1.57 | 17.26 | -23.89 | -13 | -10.89 | Vertical |
| 310.2 | -36.16 | 1.78 | 16.35 | -21.59 | -13 | -8.59 | Horizontal |
| Test Results for Mid Channel 1732.5MHz | | | | | | | |
| 3465.0 | -50.50 | 4.03 | 30.00 | -24.53 | -13 | -11.53 | Horizontal |
| 3465.0 | -50.34 | 4.03 | 30.00 | -24.37 | -13 | -11.37 | Vertical |
| 5197.5 | -48.18 | 5.25 | 35.86 | -17.57 | -13 | -4.57 | Vertical |
| 5197.5 | -49.25 | 5.25 | 35.86 | -18.64 | -13 | -5.64 | Horizontal |
| 208.7 | -40.68 | 1.44 | 17.95 | -24.17 | -13 | -11.17 | Vertical |
| 269.5 | -33.04 | 1.65 | 16.09 | -18.60 | -13 | -5.60 | Horizontal |
| Test Results for High Channel 1745MHz | | | | | | | |
| 3490.0 | -45.38 | 2.91 | 27.68 | -20.61 | -13 | -7.61 | Horizontal |
| 3490.0 | -46.06 | 2.91 | 27.68 | -21.29 | -13 | -8.29 | Vertical |
| 5235.0 | -46.54 | 5.26 | 35.86 | -15.94 | -13 | -2.94 | Vertical |
| 5235.0 | -52.94 | 5.26 | 35.86 | -22.34 | -13 | -9.34 | Horizontal |
| 184.8 | -41.05 | 1.61 | 16.85 | -25.81 | -13 | -12.81 | Vertical |
| 290.8 | -40.87 | 1.61 | 15.19 | -27.29 | -13 | -14.29 | Horizontal |

Note: P_{Mea}(dBm)= Power(dBm)+ AR_{pl} (dBm)

Over Limit= : P_{Mea}(dBm)-Limit(dBm)

Both QPSK and 16QAM has been tested, the worst case is QPSK mode, the report just reported the worst case.

9.3 LTE BAND 5

QPSK EIRP POWER FOR LTE BAND 5 (1.4MHZ BANDWIDTH)

| Test Results for Low Channel 824.7MHz | | | | | | | |
|--|---------------|----------------|--------------------|---------------------|-------------|-------------|------------|
| Frequency(MHz) | SG Level(dBm) | Cable Loss(dB) | Antenna Factor(dB) | Absolute Level(dBm) | Limit (dBm) | Margin(dBm) | Polarity |
| 1649.4 | -46.67 | 2.78 | 27.50 | -21.95 | -13 | -8.95 | Horizontal |
| 1649.4 | -50.02 | 2.78 | 27.50 | -25.30 | -13 | -12.30 | Vertical |
| 2474.1 | -45.67 | 2.90 | 27.80 | -20.77 | -13 | -7.77 | Vertical |
| 2474.1 | -50.89 | 2.90 | 27.80 | -25.99 | -13 | -12.99 | Horizontal |
| 179.0 | -36.17 | 1.76 | 17.59 | -20.34 | -13 | -7.34 | Vertical |
| 460.3 | -40.10 | 1.63 | 15.87 | -25.86 | -13 | -12.86 | Horizontal |
| Test Results For Mid Channel 836.5MHz | | | | | | | |
| 1673.0 | -46.17 | 2.80 | 27.48 | -21.49 | -13 | -8.49 | Horizontal |
| 1673.0 | -45.50 | 2.80 | 27.48 | -20.82 | -13 | -7.82 | Vertical |
| 2509.5 | -44.04 | 2.91 | 27.70 | -19.25 | -13 | -6.25 | Vertical |
| 2509.5 | -50.56 | 2.91 | 27.70 | -25.77 | -13 | -12.77 | Horizontal |
| 212.9 | -40.27 | 1.61 | 15.68 | -26.20 | -13 | -13.20 | Vertical |
| 431.5 | -36.15 | 1.59 | 17.52 | -20.23 | -13 | -7.23 | Horizontal |
| Test Results for High Channel 848.3MHz | | | | | | | |
| 1696.6 | -49.20 | 2.82 | 27.43 | -24.59 | -13 | -11.59 | Horizontal |
| 1696.6 | -50.75 | 2.82 | 27.43 | -26.14 | -13 | -13.14 | Vertical |
| 2544.9 | -43.87 | 2.92 | 27.74 | -19.05 | -13 | -6.05 | Vertical |
| 2544.9 | -51.07 | 2.92 | 27.74 | -26.25 | -13 | -13.25 | Horizontal |
| 192.7 | -35.01 | 1.69 | 16.67 | -20.02 | -13 | -7.02 | Vertical |
| 366.5 | -34.56 | 1.70 | 17.18 | -19.08 | -13 | -6.08 | Horizontal |

QPSK EIRP POWER FOR LTE BAND 5 (10MHZ BANDWIDTH)

| Test Results for Low Channel 829MHz | | | | | | | |
|---------------------------------------|---------------|----------------|--------------------|---------------------|-------------|-------------|------------|
| Frequency(MHz) | SG Level(dBm) | Cable Loss(dB) | Antenna Factor(dB) | Absolute Level(dBm) | Limit (dBm) | Margin(dBm) | Polarity |
| 1658.0 | -51.82 | 2.78 | 27.50 | -27.10 | -13 | -14.10 | Horizontal |
| 1658.0 | -42.34 | 2.78 | 27.50 | -17.62 | -13 | -4.62 | Vertical |
| 2487.0 | -51.37 | 2.90 | 27.80 | -26.47 | -13 | -13.47 | Vertical |
| 2487.0 | -48.45 | 2.90 | 27.80 | -23.55 | -13 | -10.55 | Horizontal |
| 199.8 | -42.80 | 1.71 | 15.57 | -28.94 | -13 | -15.94 | Vertical |
| 363.9 | -33.32 | 1.34 | 16.40 | -18.26 | -13 | -5.26 | Horizontal |
| Test Results for Mid Channel 836.5MHz | | | | | | | |
| 1673.0 | -42.52 | 2.80 | 27.48 | -17.84 | -13 | -4.84 | Horizontal |
| 1673.0 | -43.20 | 2.80 | 27.48 | -18.52 | -13 | -5.52 | Vertical |
| 2509.5 | -50.58 | 2.91 | 27.70 | -25.79 | -13 | -12.79 | Vertical |
| 2509.5 | -47.28 | 2.91 | 27.70 | -22.49 | -13 | -9.49 | Horizontal |
| 212.0 | -33.78 | 1.44 | 17.04 | -18.18 | -13 | -5.18 | Vertical |
| 343.3 | -41.97 | 1.76 | 17.62 | -26.11 | -13 | -13.11 | Horizontal |
| Test Results for High Channel 844MHz | | | | | | | |
| 1688.0 | -45.73 | 2.82 | 27.43 | -21.12 | -13 | -8.12 | Horizontal |
| 1688.0 | -47.42 | 2.82 | 27.43 | -22.81 | -13 | -9.81 | Vertical |
| 2532.0 | -50.84 | 2.92 | 27.74 | -26.02 | -13 | -13.02 | Vertical |
| 2532.0 | -48.07 | 2.92 | 27.74 | -23.25 | -13 | -10.25 | Horizontal |
| 205.3 | -35.24 | 1.74 | 17.70 | -19.28 | -13 | -6.28 | Vertical |
| 393.0 | -34.59 | 1.41 | 17.46 | -18.53 | -13 | -5.53 | Horizontal |

Note: P_{Mea}(dBm)= Power(dBm)+ AR_{pl} (dBm)

. Over Limit= : P_{Mea}(dBm)-Limit(dBm)

. Both QPSK and 16QAM has been tested, the worst case is QPSK mode, the report just reported the worst case.

9.4 LTE BAND 7

QPSK EIRP POWER FOR LTE BAND 7 (5.0MHZ BANDWIDTH)

| Test Results for Low Channel 2502.5MHz | | | | | | | |
|---|---------------|----------------|--------------------|---------------------|-------------|-------------|------------|
| Frequency(MHz) | SG Level(dBm) | Cable Loss(dB) | Antenna Factor(dB) | Absolute Level(dBm) | Limit (dBm) | Margin(dBm) | Polarity |
| 5005.0 | -63.32 | 5.23 | 35.81 | -32.74 | -25 | -7.74 | Horizontal |
| 5005.0 | -62.54 | 5.23 | 35.81 | -31.96 | -25 | -6.96 | Vertical |
| 7507.5 | -63.37 | 5.67 | 36.85 | -32.19 | -25 | -7.19 | Vertical |
| 7507.5 | -62.33 | 5.67 | 36.85 | -31.15 | -25 | -6.15 | Horizontal |
| 202.7 | -50.93 | 1.73 | 17.97 | -34.69 | -25 | -9.69 | Vertical |
| 450.7 | -49.68 | 1.38 | 15.11 | -35.95 | -25 | -10.95 | Horizontal |
| Test Results for Mid Channel 2535MHz | | | | | | | |
| 5070.0 | -59.73 | 5.23 | 35.82 | -29.14 | -25 | -4.14 | Horizontal |
| 5070.0 | -63.35 | 5.23 | 35.82 | -32.76 | -25 | -7.76 | Vertical |
| 7605.0 | -63.56 | 5.67 | 36.85 | -32.38 | -25 | -7.38 | Vertical |
| 7605.0 | -63.27 | 5.67 | 36.85 | -32.09 | -25 | -7.09 | Horizontal |
| 210.9 | -43.85 | 1.77 | 16.17 | -29.44 | -25 | -4.44 | Vertical |
| 232.7 | -50.11 | 1.63 | 15.21 | -36.53 | -25 | -11.53 | Horizontal |
| Test Results for High Channel 2567.5MHz | | | | | | | |
| 5135.0 | -59.42 | 5.24 | 35.83 | -28.83 | -25 | -3.83 | Horizontal |
| 5135.0 | -58.05 | 5.24 | 35.83 | -27.46 | -25 | -2.46 | Vertical |
| 7702.5 | -61.67 | 5.68 | 36.87 | -30.48 | -25 | -5.48 | Vertical |
| 7702.5 | -59.77 | 5.68 | 36.87 | -28.58 | -25 | -3.58 | Horizontal |
| 186.4 | -44.11 | 1.58 | 17.56 | -28.13 | -25 | -3.13 | Vertical |
| 263.7 | -48.22 | 1.45 | 16.58 | -33.09 | -25 | -8.09 | Horizontal |

QPSK EIRP POWER FOR LTE BAND 7 (20.0MHZ BANDWIDTH)

| Test Results for Low Channel 2510MHz | | | | | | | |
|---------------------------------------|---------------|----------------|--------------------|---------------------|-------------|-------------|------------|
| Frequency(MHz) | SG Level(dBm) | Cable Loss(dB) | Antenna Factor(dB) | Absolute Level(dBm) | Limit (dBm) | Margin(dBm) | Polarity |
| 5020.0 | -60.33 | 5.23 | 35.82 | -29.74 | -25 | -4.74 | Horizontal |
| 5020.0 | -62.48 | 5.23 | 35.82 | -31.89 | -25 | -6.89 | Vertical |
| 7530.0 | -61.45 | 5.67 | 36.86 | -30.26 | -25 | -5.26 | Vertical |
| 7530.0 | -59.61 | 5.67 | 36.86 | -28.42 | -25 | -3.42 | Horizontal |
| 192.6 | -49.08 | 1.63 | 15.76 | -34.95 | -25 | -9.95 | Vertical |
| 379.3 | -51.38 | 1.71 | 15.44 | -37.65 | -25 | -12.65 | Horizontal |
| Test Results for Mid Channel 2535MHz | | | | | | | |
| 5070.0 | -62.07 | 5.23 | 35.82 | -31.48 | -25 | -6.48 | Horizontal |
| 5070.0 | -58.45 | 5.23 | 35.82 | -27.86 | -25 | -2.86 | Vertical |
| 7605.0 | -61.03 | 5.67 | 36.85 | -29.85 | -25 | -4.85 | Vertical |
| 7605.0 | -59.91 | 5.67 | 36.85 | -28.73 | -25 | -3.73 | Horizontal |
| 198.7 | -45.83 | 1.79 | 16.84 | -30.77 | -25 | -5.77 | Vertical |
| 346.1 | -44.64 | 1.71 | 17.64 | -28.71 | -25 | -3.71 | Horizontal |
| Test Results for High Channel 2560MHz | | | | | | | |
| 5120.0 | -60.02 | 5.24 | 35.83 | -29.43 | -25 | -4.43 | Horizontal |
| 5120.0 | -60.29 | 5.24 | 35.83 | -29.70 | -25 | -4.70 | Vertical |
| 7680.0 | -60.35 | 5.70 | 36.88 | -29.17 | -25 | -4.17 | Vertical |
| 7680.0 | -61.04 | 5.70 | 36.88 | -29.86 | -25 | -4.86 | Horizontal |
| 193.4 | -45.04 | 1.79 | 16.84 | -29.98 | -25 | -4.98 | Vertical |
| 349.4 | -43.76 | 1.71 | 17.64 | -27.83 | -25 | -2.83 | Horizontal |

Note: Spurious Emission Level = Spectrum Analyzer Read Value + Cable Loss+ Antenna Factor + 11.74

. Margin = Spurious Emission Level - Limit

. Both QPSK and 16QAM has been tested, the worst case is QPSK mode, the report just reported the worst case.

9.5 LTE BAND 12

QPSK EIRP POWER FOR LTE BAND 12 (1.4MHZ BANDWIDTH)

| Test Results for Low Channel 699.7MHz | | | | | | | |
|---|---------------|----------------|--------------------|---------------------|-------------|-------------|------------|
| Frequency(MHz) | SG Level(dBm) | Cable Loss(dB) | Antenna Factor(dB) | Absolute Level(dBm) | Limit (dBm) | Margin(dBm) | Polarity |
| 1399.4 | -43.88 | 2.60 | 27.20 | -19.28 | -13 | -6.28 | Horizontal |
| 1399.4 | -43.99 | 2.60 | 27.20 | -19.39 | -13 | -6.39 | Vertical |
| 2099.1 | -50.13 | 2.85 | 27.54 | -25.44 | -13 | -12.44 | Vertical |
| 2099.1 | -49.02 | 2.85 | 27.54 | -24.33 | -13 | -11.33 | Horizontal |
| 211.7 | -36.33 | 1.49 | 17.78 | -20.04 | -13 | -7.04 | Vertical |
| 386.4 | -40.47 | 1.36 | 17.33 | -24.50 | -13 | -11.50 | Horizontal |
| Test Results For Mid Channel 707.5MHz | | | | | | | |
| 1415.0 | -46.84 | 2.61 | 27.28 | -22.17 | -13 | -9.17 | Horizontal |
| 1415.0 | -44.66 | 2.61 | 27.28 | -19.99 | -13 | -6.99 | Vertical |
| 2122.5 | -51.80 | 2.87 | 27.59 | -27.08 | -13 | -14.08 | Vertical |
| 2122.5 | -50.20 | 2.87 | 27.59 | -25.48 | -13 | -12.48 | Horizontal |
| 207.5 | -38.50 | 1.73 | 15.74 | -24.49 | -13 | -11.49 | Vertical |
| 384.6 | -33.36 | 1.62 | 15.79 | -19.19 | -13 | -6.19 | Horizontal |
| Test Results for High Channel 715.3MHz | | | | | | | |
| 1430.6 | -51.85 | 2.63 | 27.28 | -27.20 | -13 | -14.20 | Horizontal |
| 1430.6 | -47.16 | 2.63 | 27.28 | -22.51 | -13 | -9.51 | Vertical |
| 2145.9 | -44.11 | 2.88 | 27.60 | -19.39 | -13 | -6.39 | Vertical |
| 2145.9 | -48.74 | 2.88 | 27.60 | -24.02 | -13 | -11.02 | Horizontal |
| 186.4 | -33.64 | 1.61 | 18.00 | -17.25 | -13 | -4.25 | Vertical |
| 280.4 | -35.23 | 1.45 | 15.49 | -21.20 | -13 | -8.20 | Horizontal |

QPSK EIRP POWER FOR LTE BAND 12 (10MHZ BANDWIDTH)

| Test Results for Low Channel 704MHz | | | | | | | |
|---------------------------------------|---------------|----------------|--------------------|---------------------|-------------|-------------|------------|
| Frequency(MHz) | SG Level(dBm) | Cable Loss(dB) | Antenna Factor(dB) | Absolute Level(dBm) | Limit (dBm) | Margin(dBm) | Polarity |
| 1408.0 | -53.15 | 2.61 | 27.26 | -28.50 | -13 | -15.50 | Horizontal |
| 1408.0 | -46.13 | 2.61 | 27.26 | -21.48 | -13 | -8.48 | Vertical |
| 2112.0 | -48.04 | 2.87 | 27.58 | -23.33 | -13 | -10.33 | Vertical |
| 2112.0 | -51.68 | 2.87 | 27.58 | -26.97 | -13 | -13.97 | Horizontal |
| 197.3 | -40.17 | 1.31 | 16.97 | -24.51 | -13 | -11.51 | Vertical |
| 468.6 | -43.72 | 1.65 | 16.70 | -28.67 | -13 | -15.67 | Horizontal |
| Test Results for Mid Channel 707.5MHz | | | | | | | |
| 1415.0 | -45.49 | 2.61 | 27.28 | -20.82 | -13 | -7.82 | Horizontal |
| 1415.0 | -52.43 | 2.61 | 27.28 | -27.76 | -13 | -14.76 | Vertical |
| 2122.5 | -51.88 | 2.87 | 27.59 | -27.16 | -13 | -14.16 | Vertical |
| 2122.5 | -50.98 | 2.87 | 27.59 | -26.26 | -13 | -13.26 | Horizontal |
| 175.4 | -36.45 | 1.72 | 17.99 | -20.18 | -13 | -7.18 | Vertical |
| 362.7 | -39.86 | 1.73 | 17.94 | -23.65 | -13 | -10.65 | Horizontal |
| Test Results for High Channel 711MHz | | | | | | | |
| 1422.0 | -49.09 | 2.62 | 27.28 | -24.43 | -13 | -11.43 | Horizontal |
| 1422.0 | -44.81 | 2.62 | 27.28 | -20.15 | -13 | -7.15 | Vertical |
| 2133.0 | -52.89 | 2.87 | 27.60 | -28.16 | -13 | -15.16 | Vertical |
| 2133.0 | -50.10 | 2.87 | 27.60 | -25.37 | -13 | -12.37 | Horizontal |
| 209.0 | -37.40 | 1.58 | 15.93 | -23.05 | -13 | -10.05 | Vertical |
| 360.9 | -33.43 | 1.36 | 15.59 | -19.20 | -13 | -6.20 | Horizontal |

Note: P_{Mea}(dBm)= Power(dBm)+ AR_{pl} (dBm)

. Over Limit= : P_{Mea}(dBm)-Limit(dBm)

. Both QPSK and 16QAM has been tested, the worst case is QPSK mode, the report just reported the worst case.

9.6 LTE BAND 17

QPSK EIRP POWER FOR LTE BAND 17 (5MHZ BANDWIDTH)

| Test Results for Low Channel 706.5MHz | | | | | | | |
|--|---------------|----------------|--------------------|---------------------|-------------|-------------|------------|
| Frequency(MHz) | SG Level(dBm) | Cable Loss(dB) | Antenna Factor(dB) | Absolute Level(dBm) | Limit (dBm) | Margin(dBm) | Polarity |
| 1413.0 | -49.17 | 2.61 | 27.28 | -24.50 | -13 | -11.50 | Horizontal |
| 1413.0 | -45.60 | 2.61 | 27.28 | -20.93 | -13 | -7.93 | Vertical |
| 2119.5 | -51.71 | 2.87 | 27.59 | -26.99 | -13 | -13.99 | Vertical |
| 2119.5 | -51.06 | 2.87 | 27.59 | -26.34 | -13 | -13.34 | Horizontal |
| 209.6 | -34.86 | 1.71 | 16.15 | -20.42 | -13 | -7.42 | Vertical |
| 420.5 | -43.94 | 1.41 | 17.32 | -28.03 | -13 | -15.03 | Horizontal |
| Test Results For Mid Channel 710MHz | | | | | | | |
| 1420.0 | -44.73 | 2.62 | 27.30 | -20.05 | -13 | -7.05 | Horizontal |
| 1420.0 | -47.96 | 2.62 | 27.30 | -23.28 | -13 | -10.28 | Vertical |
| 2130.0 | -43.15 | 2.87 | 27.62 | -18.40 | -13 | -5.40 | Vertical |
| 2130.0 | -51.29 | 2.87 | 27.62 | -26.54 | -13 | -13.54 | Horizontal |
| 201.1 | -37.19 | 1.42 | 15.25 | -23.37 | -13 | -10.37 | Vertical |
| 320.8 | -41.41 | 1.36 | 17.19 | -25.58 | -13 | -12.58 | Horizontal |
| Test Results for High Channel 713.5MHz | | | | | | | |
| 1427.0 | -50.51 | 2.66 | 27.28 | -25.89 | -13 | -12.89 | Horizontal |
| 1427.0 | -45.77 | 2.66 | 27.28 | -21.15 | -13 | -8.15 | Vertical |
| 2140.5 | -45.72 | 2.88 | 27.60 | -21.00 | -13 | -8.00 | Vertical |
| 2140.5 | -52.02 | 2.88 | 27.60 | -27.30 | -13 | -14.30 | Horizontal |
| 175.6 | -40.89 | 1.32 | 17.29 | -24.92 | -13 | -11.92 | Vertical |
| 445.7 | -37.47 | 1.72 | 16.89 | -22.30 | -13 | -9.30 | Horizontal |

QPSK EIRP POWER FOR LTE BAND 17 (10MHZ BANDWIDTH)

| Test Results for Low Channel 709MHz | | | | | | | |
|--------------------------------------|---------------|----------------|--------------------|---------------------|-------------|-------------|------------|
| Frequency(MHz) | SG Level(dBm) | Cable Loss(dB) | Antenna Factor(dB) | Absolute Level(dBm) | Limit (dBm) | Margin(dBm) | Polarity |
| 1418.0 | -48.99 | 2.62 | 27.30 | -24.31 | -13 | -11.31 | Horizontal |
| 1418.0 | -52.79 | 2.62 | 27.30 | -28.11 | -13 | -15.11 | Vertical |
| 2127.0 | -47.93 | 2.87 | 27.62 | -23.18 | -13 | -10.18 | Vertical |
| 2127.0 | -48.39 | 2.87 | 27.62 | -23.64 | -13 | -10.64 | Horizontal |
| 196.4 | -35.19 | 1.35 | 16.91 | -19.63 | -13 | -6.63 | Vertical |
| 269.0 | -41.79 | 1.62 | 16.31 | -27.10 | -13 | -14.10 | Horizontal |
| Test Results for Mid Channel 710MHz | | | | | | | |
| 1420.0 | -43.65 | 2.62 | 27.30 | -18.97 | -13 | -5.97 | Horizontal |
| 1420.0 | -43.24 | 2.62 | 27.30 | -18.56 | -13 | -5.56 | Vertical |
| 2130.0 | -47.52 | 2.87 | 27.62 | -22.77 | -13 | -9.77 | Vertical |
| 2130.0 | -51.19 | 2.87 | 27.62 | -26.44 | -13 | -13.44 | Horizontal |
| 202.1 | -43.31 | 1.51 | 17.14 | -27.68 | -13 | -14.68 | Vertical |
| 398.2 | -39.28 | 1.77 | 16.88 | -24.17 | -13 | -11.17 | Horizontal |
| Test Results for High Channel 711MHz | | | | | | | |
| 1422.0 | -46.34 | 2.62 | 27.30 | -21.66 | -13 | -8.66 | Horizontal |
| 1422.0 | -52.29 | 2.62 | 27.30 | -27.61 | -13 | -14.61 | Vertical |
| 2133.0 | -43.72 | 2.87 | 27.62 | -18.97 | -13 | -5.97 | Vertical |
| 2133.0 | -52.56 | 2.87 | 27.62 | -27.81 | -13 | -14.81 | Horizontal |
| 201.8 | -38.37 | 1.78 | 15.95 | -24.20 | -13 | -11.20 | Vertical |
| 411.8 | -37.61 | 1.34 | 17.95 | -21.01 | -13 | -8.01 | Horizontal |

Note: Spurious Emission Level = Spectrum Analyzer Read Value + Cable Loss+ Antenna Factor + 11.74

. Margin = Spurious Emission Level - Limit

. Both QPSK and 16QAM has been tested, the worst case is QPSK mode, the report just reported the worst case.

9.7 LTE BAND 41

QPSK EIRP POWER FOR LTE BAND 41 (5MHZ BANDWIDTH)

| Test Results for Low Channel 2498.5MHz | | | | | | | |
|---|---------------|----------------|--------------------|---------------------|-------------|-------------|------------|
| Frequency(MHz) | SG Level(dBm) | Cable Loss(dB) | Antenna Factor(dB) | Absolute Level(dBm) | Limit (dBm) | Margin(dBm) | Polarity |
| 5145.0 | -59.67 | 5.23 | 35.81 | -29.09 | -25 | -4.09 | Horizontal |
| 5145.0 | -59.74 | 5.23 | 35.81 | -29.16 | -25 | -4.16 | Vertical |
| 7717.5 | -58.96 | 5.67 | 36.85 | -27.78 | -25 | -2.78 | Vertical |
| 7717.5 | -63.64 | 5.67 | 36.85 | -32.46 | -25 | -7.46 | Horizontal |
| 435.3 | -43.51 | 1.38 | 15.98 | -28.91 | -25 | -3.91 | Vertical |
| 465.8 | -42.87 | 1.62 | 15.66 | -28.83 | -25 | -3.83 | Horizontal |
| Test Results for Mid Channel 2593MHz | | | | | | | |
| 5190.0 | -63.45 | 5.23 | 35.82 | -32.86 | -25 | -7.86 | Horizontal |
| 5190.0 | -58.80 | 5.23 | 35.82 | -28.21 | -25 | -3.21 | Vertical |
| 7785.0 | -61.87 | 5.67 | 36.85 | -30.69 | -25 | -5.69 | Vertical |
| 7785.0 | -62.81 | 5.67 | 36.85 | -31.63 | -25 | -6.63 | Horizontal |
| 510.4 | -47.31 | 1.62 | 16.17 | -32.76 | -25 | -7.76 | Vertical |
| 562.9 | -43.85 | 1.74 | 17.63 | -27.96 | -25 | -2.96 | Horizontal |
| Test Results for High Channel 2687.5MHz | | | | | | | |
| 5235.0 | -58.73 | 5.24 | 35.83 | -28.14 | -25 | -3.14 | Horizontal |
| 5235.0 | -60.26 | 5.24 | 35.83 | -29.67 | -25 | -4.67 | Vertical |
| 7852.5 | -61.20 | 5.68 | 36.87 | -30.01 | -25 | -5.01 | Vertical |
| 7852.5 | -59.37 | 5.68 | 36.87 | -28.18 | -25 | -3.18 | Horizontal |
| 197.6 | -43.55 | 1.55 | 15.84 | -29.26 | -25 | -4.26 | Vertical |
| 353.1 | -46.63 | 1.51 | 17.06 | -31.08 | -25 | -6.08 | Horizontal |

QPSK EIRP POWER FOR LTE BAND 41 (20MHZ BANDWIDTH)

| Test Results for Low Channel 2506MHz | | | | | | | |
|---------------------------------------|---------------|----------------|--------------------|---------------------|-------------|-------------|------------|
| Frequency(MHz) | SG Level(dBm) | Cable Loss(dB) | Antenna Factor(dB) | Absolute Level(dBm) | Limit (dBm) | Margin(dBm) | Polarity |
| 5160.0 | -61.97 | 5.23 | 35.82 | -31.38 | -25 | -6.38 | Horizontal |
| 5160.0 | -60.44 | 5.23 | 35.82 | -29.85 | -25 | -4.85 | Vertical |
| 7740.0 | -62.41 | 5.67 | 36.86 | -31.22 | -25 | -6.22 | Vertical |
| 7740.0 | -61.73 | 5.67 | 36.86 | -30.54 | -25 | -5.54 | Horizontal |
| 128.9 | -45.27 | 1.43 | 15.51 | -31.19 | -25 | -6.19 | Vertical |
| 344.8 | -43.56 | 1.40 | 16.97 | -27.99 | -25 | -2.99 | Horizontal |
| Test Results for Mid Channel 2593MHz | | | | | | | |
| 5190.0 | -60.74 | 5.23 | 35.82 | -30.15 | -25 | -5.15 | Horizontal |
| 5190.0 | -60.05 | 5.23 | 35.82 | -29.46 | -25 | -4.46 | Vertical |
| 7785.0 | -59.51 | 5.67 | 36.85 | -28.33 | -25 | -3.33 | Vertical |
| 7785.0 | -62.13 | 5.67 | 36.85 | -30.95 | -25 | -5.95 | Horizontal |
| 100.8 | -48.25 | 1.77 | 16.72 | -33.30 | -25 | -8.30 | Vertical |
| 263.5 | -48.21 | 1.31 | 16.99 | -32.53 | -25 | -7.53 | Horizontal |
| Test Results for High Channel 2680MHz | | | | | | | |
| 5220.0 | -63.62 | 5.24 | 35.83 | -33.03 | -25 | -8.03 | Horizontal |
| 5220.0 | -62.84 | 5.24 | 35.83 | -32.25 | -25 | -7.25 | Vertical |
| 7830.0 | -59.27 | 5.70 | 36.88 | -28.09 | -25 | -3.09 | Vertical |
| 7830.0 | -61.22 | 5.70 | 36.88 | -30.04 | -25 | -5.04 | Horizontal |
| 349.9 | -48.51 | 1.70 | 15.73 | -34.48 | -25 | -9.48 | Vertical |
| 110.3 | -43.74 | 1.75 | 17.33 | -28.16 | -25 | -3.16 | Horizontal |

Note: P_{Mea}(dBm)= Power(dBm)+ ARpl (dBm)

. Over Limit= : P_{Mea}(dBm)-Limit(dBm)

. We test both H direction and V direction, recorded worst case direction.

Both QPSK and 16QAM has been tested, the worst case is QPSK mode, the report just reported the worst case.

10. FREQUENCY STABILITY

RULE PART(S)

FCC: §2.1055, §22.355, §24.235, §27.54, §90.213

LIMITS

§22.355 - The carrier frequency shall not depart from the reference frequency in excess of ± 2.5 ppm for mobile stations.

§24.235 - The frequency stability shall be sufficient to ensure that the fundamental emission stays within the authorized frequency block.

TEST PROCEDURE

Use CMW 500 with Frequency Error measurement capability.

Temp. = -30° to $+50^{\circ}$ C

Voltage = low voltage, DC 3.27V, Normal, DC 3.85V and High voltage, DC 4.43V.

Frequency Stability vs Temperature:

The EUT is placed inside a temperature chamber. The temperature is set to -30° C and allowed to stabilize. After sufficient soak time, the transmitting frequency error is measured. The temperature is increased by 10 degrees, allowed to stabilize and soak, and then the measurement is repeated. This is repeated until $+50^{\circ}$ C is reached.

Frequency Stability vs Voltage:

The peak frequency error is recorded (worst-case).

MODES TESTED

LTE Band 2/4/5/7/12/17/41

RESULTS

See the following pages.

10.1 LTE BAND 2

Band 2 QPSK, (20MHz BANDWIDTH RB size 100 RB Offset 0)

Frequency error vs. Voltage

| Voltage [Vdc] | Frequency [MHz] | Frequency* Error[Hz] | Frequency Error[ppm] | Limit [ppm] |
|---------------|-----------------|----------------------|----------------------|-------------|
| 3.27 | 1880 | 10.5 | 0.005585 | 2.5 |
| 3.85 | 1880 | 6.6 | 0.003511 | 2.5 |
| 4.43 | 1880 | 9.3 | 0.004947 | 2.5 |

Frequency error vs. Temperature

| Temperature [°C] | Frequency [MHz] | Frequency* Error[Hz] | Frequency Error[ppm] | Limit [ppm] |
|------------------|-----------------|----------------------|----------------------|-------------|
| Normal (25C) | 1880 | 14.8 | 0.007872 | 2.5 |
| Extreme (50C) | 1880 | 12.6 | 0.006702 | 2.5 |
| Extreme (40C) | 1880 | 7.1 | 0.003777 | 2.5 |
| Extreme (30C) | 1880 | 5.2 | 0.002766 | 2.5 |
| Extreme (10C) | 1880 | 10.4 | 0.005532 | 2.5 |
| Extreme (0C) | 1880 | 5.6 | 0.002979 | 2.5 |
| Extreme (-10C) | 1880 | 5.1 | 0.002713 | 2.5 |
| Extreme (-20C) | 1880 | 11.9 | 0.006330 | 2.5 |
| Extreme (-30C) | 1880 | 9.6 | 0.005106 | 2.5 |

Band 2 16QAM, (20MHz BANDWIDTH RB size 100 RB Offset 0)

Frequency error vs. Voltage

| Voltage [Vdc] | Frequency [MHz] | Frequency* Error[Hz] | Frequency Error[ppm] | Limit [ppm] |
|---------------|-----------------|----------------------|----------------------|-------------|
| 3.27 | 1880 | 14.1 | 0.007500 | 2.5 |
| 3.85 | 1880 | 11.6 | 0.006170 | 2.5 |
| 4.43 | 1880 | 10.1 | 0.005372 | 2.5 |

Frequency error vs. Temperature

| Temperature [°C] | Frequency [MHz] | Frequency* Error[Hz] | Frequency Error[ppm] | Limit [ppm] |
|------------------|-----------------|----------------------|----------------------|-------------|
| Normal (25C) | 1880 | 11.1 | 0.005904 | 2.5 |
| Extreme (50C) | 1880 | 9.2 | 0.004894 | 2.5 |
| Extreme (40C) | 1880 | 14.6 | 0.007766 | 2.5 |
| Extreme (30C) | 1880 | 6.4 | 0.003404 | 2.5 |
| Extreme (10C) | 1880 | 7.5 | 0.003989 | 2.5 |
| Extreme (0C) | 1880 | 7.2 | 0.003830 | 2.5 |
| Extreme (-10C) | 1880 | 6.6 | 0.003511 | 2.5 |
| Extreme (-20C) | 1880 | 5.1 | 0.002713 | 2.5 |
| Extreme (-30C) | 1880 | 10.2 | 0.005426 | 2.5 |

***Note:** Frequency error measurements were made by using the build-in capability of the Wireless Communication Test Set.

10.2 LTE BAND 4

Band 4 QPSK, (20MHz BANDWIDTH RB size 100 RB Offset 0)

Frequency error vs. Voltage

| Voltage [Vdc] | Frequency [MHz] | Frequency* Error[Hz] | Frequency Error[ppm] | Limit [ppm] |
|---------------|-----------------|----------------------|----------------------|-------------|
| 3.27 | 1732.5 | 14.4 | 0.008312 | 2.5 |
| 3.85 | 1732.5 | 11.1 | 0.006407 | 2.5 |
| 4.43 | 1732.5 | 8.2 | 0.004733 | 2.5 |

Frequency error vs. Temperature

| Temperature [°C] | Frequency [MHz] | Frequency* Error[Hz] | Frequency Error[ppm] | Limit [ppm] |
|------------------|-----------------|----------------------|----------------------|-------------|
| Normal (25C) | 1732.5 | 14.2 | 0.008196 | 2.5 |
| Extreme (50C) | 1732.5 | 15.1 | 0.008716 | 2.5 |
| Extreme (40C) | 1732.5 | 13.6 | 0.007850 | 2.5 |
| Extreme (30C) | 1732.5 | 5.9 | 0.003405 | 2.5 |
| Extreme (10C) | 1732.5 | 13.4 | 0.007734 | 2.5 |
| Extreme (0C) | 1732.5 | 12.6 | 0.007273 | 2.5 |
| Extreme (-10C) | 1732.5 | 9.3 | 0.005368 | 2.5 |
| Extreme (-20C) | 1732.5 | 5.2 | 0.003001 | 2.5 |
| Extreme (-30C) | 1732.5 | 9.5 | 0.005483 | 2.5 |

Band 4 16QAM, (20MHz BANDWIDTH RB size 100 RB Offset 0)

Frequency error vs. Voltage

| Voltage [Vdc] | Frequency [MHz] | Frequency* Error[Hz] | Frequency Error[ppm] | Limit [ppm] |
|---------------|-----------------|----------------------|----------------------|-------------|
| 3.27 | 1732.5 | 5.4 | 0.003117 | 2.5 |
| 3.85 | 1732.5 | 7.1 | 0.004098 | 2.5 |
| 4.43 | 1732.5 | 6.6 | 0.003810 | 2.5 |

Frequency error vs. Temperature

| Temperature [°C] | Frequency [MHz] | Frequency* Error[Hz] | Frequency Error[ppm] | Limit [ppm] |
|------------------|-----------------|----------------------|----------------------|-------------|
| Normal (25C) | 1732.5 | 9.7 | 0.005599 | 2.5 |
| Extreme (50C) | 1732.5 | 9.2 | 0.005310 | 2.5 |
| Extreme (40C) | 1732.5 | 11.6 | 0.006696 | 2.5 |
| Extreme (30C) | 1732.5 | 8.6 | 0.004964 | 2.5 |
| Extreme (10C) | 1732.5 | 14.4 | 0.008312 | 2.5 |
| Extreme (0C) | 1732.5 | 10.1 | 0.005830 | 2.5 |
| Extreme (-10C) | 1732.5 | 11.6 | 0.006696 | 2.5 |
| Extreme (-20C) | 1732.5 | 6.3 | 0.003636 | 2.5 |
| Extreme (-30C) | 1732.5 | 13.7 | 0.007908 | 2.5 |

***Note:** Frequency error measurements were made by using the build-in capability of the Wireless Communication Test Set.

10.3 LTE BAND 5

Band 5 QPSK, (10MHz BANDWIDTH RB size 50 RB Offset 0)

Frequency error vs. Voltage

| Voltage [Vdc] | Frequency [MHz] | Frequency* Error[Hz] | Frequency Error[ppm] | Limit [ppm] |
|---------------|-----------------|----------------------|----------------------|-------------|
| 3.27 | 836.5 | 5.2 | 0.006216 | 2.5 |
| 3.85 | 836.5 | 5.6 | 0.006695 | 2.5 |
| 4.43 | 836.5 | 10.6 | 0.012672 | 2.5 |

Frequency error vs. Temperature

| Temperature [°C] | Frequency [MHz] | Frequency* Error[Hz] | Frequency Error[ppm] | Limit [ppm] |
|------------------|-----------------|----------------------|----------------------|-------------|
| Normal (25C) | 836.5 | 9.7 | 0.011596 | 2.5 |
| Extreme (50C) | 836.5 | 7.2 | 0.008607 | 2.5 |
| Extreme (40C) | 836.5 | 10.6 | 0.012672 | 2.5 |
| Extreme (30C) | 836.5 | 5.5 | 0.006575 | 2.5 |
| Extreme (10C) | 836.5 | 8.6 | 0.010281 | 2.5 |
| Extreme (0C) | 836.5 | 13.4 | 0.016019 | 2.5 |
| Extreme (-10C) | 836.5 | 10.6 | 0.012672 | 2.5 |
| Extreme (-20C) | 836.5 | 14.6 | 0.017454 | 2.5 |
| Extreme (-30C) | 836.5 | 9.9 | 0.011835 | 2.5 |

Band 5 16QAM, (10MHz BANDWIDTH RB size 50 RB Offset 0)

Frequency error vs. Voltage

| Voltage [Vdc] | Frequency [MHz] | Frequency* Error[Hz] | Frequency Error[ppm] | Limit [ppm] |
|---------------|-----------------|----------------------|----------------------|-------------|
| 3.27 | 836.5 | 11.4 | 0.013628 | 2.5 |
| 3.85 | 836.5 | 13.6 | 0.016258 | 2.5 |
| 4.43 | 836.5 | 5.2 | 0.006216 | 2.5 |

Frequency error vs. Temperature

| Temperature [°C] | Frequency [MHz] | Frequency* Error[Hz] | Frequency Error[ppm] | Limit [ppm] |
|------------------|-----------------|----------------------|----------------------|-------------|
| Normal (25C) | 836.5 | 6.5 | 0.007770 | 2.5 |
| Extreme (50C) | 836.5 | 7.1 | 0.008488 | 2.5 |
| Extreme (40C) | 836.5 | 5.2 | 0.006216 | 2.5 |
| Extreme (30C) | 836.5 | 12.9 | 0.015421 | 2.5 |
| Extreme (10C) | 836.5 | 11.6 | 0.013867 | 2.5 |
| Extreme (0C) | 836.5 | 15.1 | 0.018051 | 2.5 |
| Extreme (-10C) | 836.5 | 12.6 | 0.015063 | 2.5 |
| Extreme (-20C) | 836.5 | 7.2 | 0.008607 | 2.5 |
| Extreme (-30C) | 836.5 | 10.4 | 0.012433 | 2.5 |

***Note:** Frequency error measurements were made by using the build-in capability of the Wireless Communication Test Set.

10.4 LTE BAND 7

Band 7 QPSK, (20MHz BANDWIDTH RB size 100 RB Offset 0)

Frequency error vs. Voltage

| Voltage [Vdc] | Frequency [MHz] | Frequency* Error[Hz] | Frequency Error[ppm] | Limit [ppm] |
|---------------|-----------------|----------------------|----------------------|-------------|
| 3.27 | 2535 | 7.5 | 0.002959 | 2.5 |
| 3.85 | 2535 | 8.1 | 0.003195 | 2.5 |
| 4.43 | 2535 | 9.2 | 0.003629 | 2.5 |

Frequency error vs. Temperature

| Temperature [°C] | Frequency [MHz] | Frequency* Error[Hz] | Frequency Error[ppm] | Limit [ppm] |
|------------------|-----------------|----------------------|----------------------|-------------|
| Normal (25C) | 2535 | 6.1 | 0.002406 | 2.5 |
| Extreme (50C) | 2535 | 13.6 | 0.005365 | 2.5 |
| Extreme (40C) | 2535 | 11.6 | 0.004576 | 2.5 |
| Extreme (30C) | 2535 | 5.5 | 0.002170 | 2.5 |
| Extreme (10C) | 2535 | 14.6 | 0.005759 | 2.5 |
| Extreme (0C) | 2535 | 11.5 | 0.004536 | 2.5 |
| Extreme (-10C) | 2535 | 8.2 | 0.003235 | 2.5 |
| Extreme (-20C) | 2535 | 11.6 | 0.004576 | 2.5 |
| Extreme (-30C) | 2535 | 8.3 | 0.003274 | 2.5 |

Band 7 16QAM, (20MHz BANDWIDTH RB size 100 RB Offset 0)

Frequency error vs. Voltage

| Voltage [Vdc] | Frequency [MHz] | Frequency* Error[Hz] | Frequency Error[ppm] | Limit [ppm] |
|---------------|-----------------|----------------------|----------------------|-------------|
| 3.27 | 2535 | 13.7 | 0.005404 | 2.5 |
| 3.85 | 2535 | 15.4 | 0.006075 | 2.5 |
| 4.43 | 2535 | 5.2 | 0.002051 | 2.5 |

Frequency error vs. Temperature

| Temperature [°C] | Frequency [MHz] | Frequency* Error[Hz] | Frequency Error[ppm] | Limit [ppm] |
|------------------|-----------------|----------------------|----------------------|-------------|
| Normal (25C) | 2535 | 5.4 | 0.002130 | 2.5 |
| Extreme (50C) | 2535 | 9.1 | 0.003590 | 2.5 |
| Extreme (40C) | 2535 | 7.6 | 0.002998 | 2.5 |
| Extreme (30C) | 2535 | 10.1 | 0.003984 | 2.5 |
| Extreme (10C) | 2535 | 12.9 | 0.005089 | 2.5 |
| Extreme (0C) | 2535 | 6.6 | 0.002604 | 2.5 |
| Extreme (-10C) | 2535 | 12.2 | 0.004813 | 2.5 |
| Extreme (-20C) | 2535 | 10.6 | 0.004181 | 2.5 |
| Extreme (-30C) | 2535 | 11.6 | 0.004576 | 2.5 |

***Note:** Frequency error measurements were made by using the build-in capability of the Wireless Communication Test Set.

10.5 LTE BAND 12

Band 12 QPSK, (10MHz BANDWIDTH RB size 50 RB Offset 0

Frequency error vs. Voltage

| Voltage [Vdc] | Frequency [MHz] | Frequency* Error[Hz] | Frequency Error[ppm] | Limit [ppm] |
|---------------|-----------------|----------------------|----------------------|-------------|
| 3.27 | 707.5 | 6.5 | 0.009187 | 2.5 |
| 3.85 | 707.5 | 7.6 | 0.010742 | 2.5 |
| 4.43 | 707.5 | 12.1 | 0.017102 | 2.5 |

Frequency error vs. Temperature

| Temperature [°C] | Frequency [MHz] | Frequency* Error[Hz] | Frequency Error[ppm] | Limit [ppm] |
|------------------|-----------------|----------------------|----------------------|-------------|
| Normal (25C) | 707.5 | 10.1 | 0.014276 | 2.5 |
| Extreme (50C) | 707.5 | 9.6 | 0.013569 | 2.5 |
| Extreme (40C) | 707.5 | 15.8 | 0.022332 | 2.5 |
| Extreme (30C) | 707.5 | 12.6 | 0.017809 | 2.5 |
| Extreme (10C) | 707.5 | 15.4 | 0.021767 | 2.5 |
| Extreme (0C) | 707.5 | 11.6 | 0.016396 | 2.5 |
| Extreme (-10C) | 707.5 | 8.1 | 0.011449 | 2.5 |
| Extreme (-20C) | 707.5 | 15.2 | 0.021484 | 2.5 |
| Extreme (-30C) | 707.5 | 7.3 | 0.010318 | 2.5 |

Band 12 16QAM, (10MHz BANDWIDTH RB size 50 RB Offset 0)

Frequency error vs. Voltage

| Voltage [Vdc] | Frequency [MHz] | Frequency* Error[Hz] | Frequency Error[ppm] | Limit [ppm] |
|---------------|-----------------|----------------------|----------------------|-------------|
| 3.27 | 707.5 | 15.4 | 0.021767 | 2.5 |
| 3.85 | 707.5 | 11.1 | 0.015689 | 2.5 |
| 4.43 | 707.5 | 5.6 | 0.007915 | 2.5 |

Frequency error vs. Temperature

| Temperature [°C] | Frequency [MHz] | Frequency* Error[Hz] | Frequency Error[ppm] | Limit [ppm] |
|------------------|-----------------|----------------------|----------------------|-------------|
| Normal (25C) | 707.5 | 10.4 | 0.014700 | 2.5 |
| Extreme (50C) | 707.5 | 14.6 | 0.020636 | 2.5 |
| Extreme (40C) | 707.5 | 13.7 | 0.019364 | 2.5 |
| Extreme (30C) | 707.5 | 14.2 | 0.020071 | 2.5 |
| Extreme (10C) | 707.5 | 5.4 | 0.007633 | 2.5 |
| Extreme (0C) | 707.5 | 9.8 | 0.013852 | 2.5 |
| Extreme (-10C) | 707.5 | 6.2 | 0.008763 | 2.5 |
| Extreme (-20C) | 707.5 | 11.6 | 0.016396 | 2.5 |
| Extreme (-30C) | 707.5 | 10.4 | 0.014700 | 2.5 |

***Note:** Frequency error measurements were made by using the build-in capability of the Wireless Communication Test Set.

10.6 LTE BAND 17

Band 17 QPSK, (10MHz BANDWIDTH RB size 50 RB Offset 0)

Frequency error vs. Voltage

| Voltage [Vdc] | Frequency [MHz] | Frequency* Error[Hz] | Frequency Error[ppm] | Limit [ppm] |
|---------------|-----------------|----------------------|----------------------|-------------|
| 3.27 | 710 | 8.4 | 0.011831 | 2.5 |
| 3.85 | 710 | 5.5 | 0.007746 | 2.5 |
| 4.43 | 710 | 6.6 | 0.009296 | 2.5 |

Frequency error vs. Temperature

| Temperature [°C] | Frequency [MHz] | Frequency* Error[Hz] | Frequency Error[ppm] | Limit [ppm] |
|------------------|-----------------|----------------------|----------------------|-------------|
| Normal (25C) | 710 | 15.6 | 0.021972 | 2.5 |
| Extreme (50C) | 710 | 6.2 | 0.008732 | 2.5 |
| Extreme (40C) | 710 | 13.1 | 0.018451 | 2.5 |
| Extreme (30C) | 710 | 4.7 | 0.006620 | 2.5 |
| Extreme (10C) | 710 | 8.5 | 0.011972 | 2.5 |
| Extreme (0C) | 710 | 11.1 | 0.015634 | 2.5 |
| Extreme (-10C) | 710 | 5.6 | 0.007887 | 2.5 |
| Extreme (-20C) | 710 | 7.7 | 0.010845 | 2.5 |
| Extreme (-30C) | 710 | 7.8 | 0.010986 | 2.5 |

Band 17 16QAM, (10MHz BANDWIDTH RB size 50 RB Offset 0)

Frequency error vs. Voltage

| Voltage [Vdc] | Frequency [MHz] | Frequency* Error[Hz] | Frequency Error[ppm] | Limit [ppm] |
|---------------|-----------------|----------------------|----------------------|-------------|
| 3.27 | 710 | 10.6 | 0.014930 | 2.5 |
| 3.85 | 710 | 11.8 | 0.016620 | 2.5 |
| 4.43 | 710 | 7.2 | 0.010141 | 2.5 |

Frequency error vs. Temperature

| Temperature [°C] | Frequency [MHz] | Frequency* Error[Hz] | Frequency Error[ppm] | Limit [ppm] |
|------------------|-----------------|----------------------|----------------------|-------------|
| Normal (25C) | 710 | 13.4 | 0.018873 | 2.5 |
| Extreme (50C) | 710 | 6.6 | 0.009296 | 2.5 |
| Extreme (40C) | 710 | 15.8 | 0.022254 | 2.5 |
| Extreme (30C) | 710 | 9.8 | 0.013803 | 2.5 |
| Extreme (10C) | 710 | 14.9 | 0.020986 | 2.5 |
| Extreme (0C) | 710 | 12.2 | 0.017183 | 2.5 |
| Extreme (-10C) | 710 | 9.2 | 0.012958 | 2.5 |
| Extreme (-20C) | 710 | 5.2 | 0.007324 | 2.5 |
| Extreme (-30C) | 710 | 12.1 | 0.017042 | 2.5 |

***Note:** Frequency error measurements were made by using the build-in capability of the Wireless Communication Test Set.

10.7 LTE BAND 41

Band 41 QPSK, (20MHz BANDWIDTH RB size 100 RB Offset 0)

Frequency error vs. Voltage

| Voltage [Vdc] | Frequency [MHz] | Frequency* Error[Hz] | Frequency Error[ppm] | Limit [ppm] |
|---------------|-----------------|----------------------|----------------------|-------------|
| 3.27 | 2593 | 8.5 | 0.003278 | 2.5 |
| 3.85 | 2593 | 6.7 | 0.002584 | 2.5 |
| 4.43 | 2593 | 7.1 | 0.002738 | 2.5 |

Frequency error vs. Temperature

| Temperature [°C] | Frequency [MHz] | Frequency* Error[Hz] | Frequency Error[ppm] | Limit [ppm] |
|------------------|-----------------|----------------------|----------------------|-------------|
| Normal (25C) | 2593 | 11.2 | 0.004319 | 2.5 |
| Extreme (50C) | 2593 | 5.5 | 0.002121 | 2.5 |
| Extreme (40C) | 2593 | 5.6 | 0.002160 | 2.5 |
| Extreme (30C) | 2593 | 4.5 | 0.001735 | 2.5 |
| Extreme (10C) | 2593 | 6.6 | 0.002545 | 2.5 |
| Extreme (0C) | 2593 | 5.8 | 0.002237 | 2.5 |
| Extreme (-10C) | 2593 | 9.2 | 0.003548 | 2.5 |
| Extreme (-20C) | 2593 | 11.3 | 0.004358 | 2.5 |
| Extreme (-30C) | 2593 | 6.1 | 0.002352 | 2.5 |

Band 41 16QAM, (20MHz BANDWIDTH RB size 100 RB Offset 0)

Frequency error vs. Voltage

| Voltage [Vdc] | Frequency [MHz] | Frequency* Error[Hz] | Frequency Error[ppm] | Limit [ppm] |
|---------------|-----------------|----------------------|----------------------|-------------|
| 3.27 | 2593 | 8.4 | 0.003239 | 2.5 |
| 3.85 | 2593 | 5.2 | 0.002005 | 2.5 |
| 4.43 | 2593 | 6.1 | 0.002352 | 2.5 |

Frequency error vs. Temperature

| Temperature [°C] | Frequency [MHz] | Frequency* Error[Hz] | Frequency Error[ppm] | Limit [ppm] |
|------------------|-----------------|----------------------|----------------------|-------------|
| Normal (25C) | 2593 | 7.2 | 0.002777 | 2.5 |
| Extreme (50C) | 2593 | 5.6 | 0.002160 | 2.5 |
| Extreme (40C) | 2593 | 5.5 | 0.002121 | 2.5 |
| Extreme (30C) | 2593 | 5.9 | 0.002275 | 2.5 |
| Extreme (10C) | 2593 | 6.8 | 0.002622 | 2.5 |
| Extreme (0C) | 2593 | 4.9 | 0.001890 | 2.5 |
| Extreme (-10C) | 2593 | 9.1 | 0.003509 | 2.5 |
| Extreme (-20C) | 2593 | 11.6 | 0.004474 | 2.5 |
| Extreme (-30C) | 2593 | 5.8 | 0.002237 | 2.5 |

***Note:** Frequency error measurements were made by using the build-in capability of the Wireless Communication Test Set.

11. Peak-to-Average Ratio

11.1 Description of the PAR Measurement

The peak-to-average ratio (PAR) of the transmission may not exceed 13 dB.

11.2 Measuring Instruments

See list of measuring instruments of this test report.

11.3 Test Procedures

1. The EUT was connected to Spectrum Analyzer and Base Station via power divider.
2. The RF output of EUT was connected to the spectrum analyzer by RF cable and attenuator. The path loss was compensated to the results for each measurement.
3. For LTE operating modes:
 - a. Set the CCDF (Complementary Cumulative Distribution Function) option in spectrum analyzer.
 - b. The highest RF powers were measured and recorded the maximum PAPR level associated with a probability of 0.1 %.

11.4 Test Setup

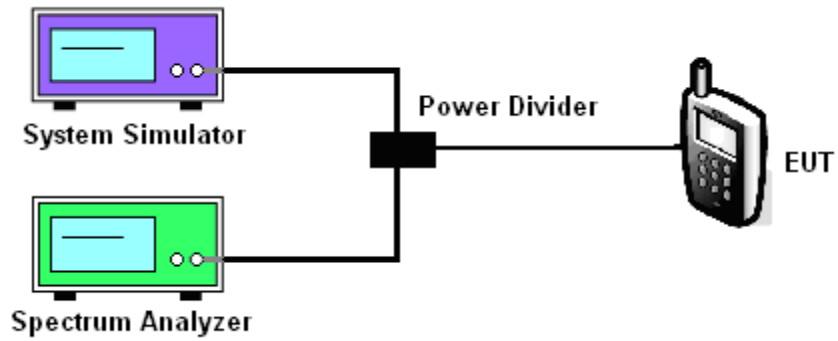

MODES TESTED

LTE Band 2/4/5/7/12/17/41

Test data reference attachment.

----END OF REPORT----