

TEST REPORT



| | |
|-----------|--|
| Applicant | Ningbo Lingzhu Technology CO., Ltd.. |
| Address | No.578, Building 7, No.535 Kangqiao South Road, Jiangbei District, Ningbo, PRC |

| | |
|-------------------------------------|--|
| Manufacturer or Supplier | Ningbo Lingzhu Technology CO., Ltd. |
| Address | No.578, Building 7, No.535 Kangqiao South Road, Jiangbei District, Ningbo, PRC |
| Product | Smart Bluetooth Gateway Pro |
| Brand Name | N/A |
| Model | THP10-B-V2 |
| Additional Model & Model Difference | N/A |
| Date of tests | Apr. 24, 2023 ~ Jun. 02, 2023 |

The tests have been carried out according to the requirements of the following standard:

FCC Part 15, Subpart C, Section 15.247

CONCLUSION: The submitted sample was found to COMPLY with the test requirement

| | |
|---|---|
| Tested by Niko Zhang Project Engineer / EMC Department | Approved by Glyn He Assistant Manager / EMC Department |
|  |  Date: Jul. 19, 2023 |

This report is governed by, and incorporates by reference, the Conditions of Testing as posted at the date of issuance of this report at <http://www.bureauveritas.com/home/about-us/our-business/cps/about-us/terms-conditions/> and is intended for your exclusive use. Any copying or replication of this report to or for any other person or entity, or use of our name or trademark, is permitted only with our prior written permission. This report sets forth our findings solely with respect to the test samples identified herein. The results set forth in this report are not indicative or representative of the quality or characteristics of the lot from which a test sample was taken or any similar or identical product unless specifically and expressly noted. Our report includes all of the tests requested by you and the results thereof based upon the information that you provided to us. Measurement uncertainty is only provided upon request for accredited tests. Statements of conformity are based on simple acceptance criteria without taking measurement uncertainty into account, unless otherwise requested in writing. You have 60 days from date of issuance of this report to notify us of any material error or omission caused by our negligence or if you require measurement uncertainty; provided, however, that such notice shall be in writing and shall specifically address the issue you wish to raise. A failure to raise such issue within the prescribed time shall constitute your unqualified acceptance of the completeness of this report, the tests conducted and the correctness of the report contents.



TABLE OF CONTENTS

| | |
|--|-----------|
| RELEASE CONTROL RECORD | 4 |
| 1 SUMMARY OF TEST RESULTS..... | 5 |
| 2 MEASUREMENT UNCERTAINTY | 5 |
| 3 GENERAL INFORMATION | 6 |
| 3.1 GENERAL DESCRIPTION OF EUT..... | 6 |
| 3.2 DESCRIPTION OF TEST MODES..... | 7 |
| 3.2.1 CONFIGURATION OF SYSTEM UNDER TEST | 8 |
| 3.2.2 TEST MODE APPLICABILITY AND TESTED CHANNEL DETAIL..... | 8 |
| 3.3 GENERAL DESCRIPTION OF APPLIED STANDARDS..... | 10 |
| 3.4 DESCRIPTION OF SUPPORT UNITS..... | 10 |
| 3.5 CONFIGURATION OF SYSTEM UNDER TEST..... | 10 |
| 3.6 DUTY CYCLE OF TESET SIGNAL | 11 |
| 4 TEST TYPES AND RESULTS..... | 12 |
| 4.1 CONDUCTED EMISSION MEASUREMENT | 12 |
| 4.1.1 LIMITS OF CONDUCTED EMISSION MEASUREMENT | 12 |
| 4.1.2 TEST INSTRUMENTS..... | 12 |
| 4.1.3 TEST PROCEDURES | 13 |
| 4.1.4 DEVIATION FROM TEST STANDARD | 13 |
| 4.1.5 TEST SETUP..... | 14 |
| 4.1.6 EUT OPERATING CONDITIONS..... | 14 |
| 4.1.7 TEST RESULTS | 15 |
| 4.2 RADIATED EMISSION MEASUREMENT | 17 |
| 4.2.1 LIMITS OF RADIATED EMISSION MEASUREMENT | 17 |
| 4.2.2 TEST INSTRUMENTS..... | 18 |
| 4.2.3 TEST PROCEDURES | 19 |
| 4.2.4 DEVIATION FROM TEST STANDARD | 20 |
| 4.2.5 TEST SETUP..... | 20 |
| 4.2.6 EUT OPERATING CONDITIONS..... | 21 |
| 4.2.7 TEST RESULTS | 22 |
| 4.3 6DB BANDWIDTH MEASUREMENT..... | 38 |
| 4.3.1 LIMITS OF 6DB BANDWIDTH MEASUREMENT | 38 |
| 4.3.2 TEST INSTRUMENTS..... | 38 |
| 4.3.3 TEST PROCEDURE..... | 38 |



Test Report No.: RF2304WDG0057

| | | |
|----------|---|-----------|
| 4.3.4 | DEVIATION FROM TEST STANDARD | 39 |
| 4.3.5 | TEST SETUP | 39 |
| 4.3.6 | EUT OPERATING CONDITIONS | 39 |
| 4.3.7 | TEST RESULTS | 40 |
| 4.4 | CONDUCTED OUTPUT POWER | 46 |
| 4.4.1 | LIMITS OF CONDUCTED OUTPUT POWER MEASUREMENT | 46 |
| 4.4.2 | TEST SETUP | 46 |
| 4.4.3 | TEST INSTRUMENTS | 46 |
| 4.4.4 | TEST PROCEDURES | 47 |
| 4.4.5 | DEVIATION FROM TEST STANDARD | 47 |
| 4.4.6 | EUT OPERATING CONDITIONS | 47 |
| 4.4.7 | TEST RESULTS | 48 |
| 4.5 | POWER SPECTRAL DENSITY MEASUREMENT | 52 |
| 4.5.1 | LIMITS OF POWER SPECTRAL DENSITY MEASUREMENT | 52 |
| 4.5.2 | TEST SETUP | 52 |
| 4.5.3 | TEST INSTRUMENTS | 52 |
| 4.5.4 | TEST PROCEDURE | 52 |
| 4.5.5 | DEVIATION FROM TEST STANDARD | 52 |
| 4.5.6 | EUT OPERATING CONDITION | 53 |
| 4.5.7 | TEST RESULTS | 53 |
| 4.6 | OUT OF BAND EMISSION MEASUREMENT | 56 |
| 4.6.1 | LIMITS OF OUT OF BAND EMISSION MEASUREMENT | 56 |
| 4.6.2 | TEST SETUP | 56 |
| 4.6.3 | TEST INSTRUMENTS | 56 |
| 4.6.4 | TEST PROCEDURE | 56 |
| 4.6.5 | DEVIATION FROM TEST STANDARD | 57 |
| 4.6.6 | EUT OPERATING CONDITION | 57 |
| 4.6.7 | TEST RESULTS | 58 |
| 5 | PHOTOGRAPHS OF THE TEST CONFIGURATION | 64 |
| 6 | APPENDIX A - MODIFICATIONS RECORDERS FOR ENGINEERING CHANGES TO THE EUT BY THE LAB | 65 |



Test Report No.: RF2304WDG0057

RELEASE CONTROL RECORD

| ISSUE NO. | REASON FOR CHANGE | DATE ISSUED |
|---------------|-------------------|---------------|
| RF2304WDG0057 | Original release | Jul. 19, 2023 |

1 SUMMARY OF TEST RESULTS

The EUT has been tested according to the following specifications:

| APPLIED STANDARD: FCC PART 15, SUBPART C (SECTION 15.247) | | | |
|---|-----------------------------|--------|--------------------------------|
| STANDARD SECTION | TEST TYPE AND LIMIT | RESULT | REMARK |
| 15.207 | AC Power Conducted Emission | PASS | Meet the requirement of limit. |
| 15.247(d) 15.209 | Radiated Emissions | PASS | Meet the requirement of limit. |
| 15.247(d) | Band Edge Measurement | PASS | Meet the requirement of limit. |
| 15.247(a)(2) | 6dB bandwidth | PASS | Meet the requirement of limit. |
| 15.247(b) | Conducted Output power | PASS | Meet the requirement of limit. |
| 15.247(e) | Power Spectral Density | PASS | Meet the requirement of limit. |
| 15.203 | Antenna Requirement | PASS | No antenna connector is used |

2 MEASUREMENT UNCERTAINTY

Where relevant, the following measurement uncertainty levels have been estimated for tests performed on the EUT as specified in CISPR 16-4-2:

| MEASUREMENT | FREQUENCY | UNCERTAINTY |
|---------------------|---------------|-------------|
| Conducted emissions | 9kHz~30MHz | 2.67dB |
| Radiated emissions | 9KHz ~ 30MHz | 2.80dB |
| | 30MHz ~ 1GMHz | 4.24dB |
| | 1GHz ~ 18GHz | 4.76dB |
| | 18GHz ~ 40GHz | 4.50dB |

This uncertainty represents an expanded uncertainty expressed at approximately the 95% confidence level using a coverage factor of $k = 2$.



3 GENERAL INFORMATION

3.1 GENERAL DESCRIPTION OF EUT

| | |
|------------------------------|---|
| PRODUCT | Smart Bluetooth Gateway Pro |
| MODEL NO. | THP10-B-V2 |
| FCC ID | 2A789THP10-B-V2 |
| NOMINAL VOLTAGE | DC 5V From Adapter |
| MODULATION TECHNOLOGY | DSSS, OFDM, GFSK |
| MODULATION TYPE | CCK, DQPSK, DBPSK for DSSS 64QAM, 16QAM, QPSK, BPSK for OFDM BT-LE for DTS |
| OPERATING FREQUENCY | 2412-2462MHz for 11b/g/n(HT20) 2402-2480MHz for BT-LE(GFSK) |
| PEAK OUTPUT POWER | WLAN: 231.206mW (Maximum) BT-LE: 79.799mW (Maximum) |
| ANTENNA TYPE | FPC Antenna, WLAN: 2.03dBi Gain BT-LE: 3.48dBi Gain |
| I/O PORTS | Refer to user's manual |
| CABLE SUPPLIED | DC LINE: Unshielded, Detachable, 0.5m Network Link: Unshielded, Detachable, 0.5m |

NOTE:

1. The EUT incorporates a SISO function. Physically, the EUT provides one transmitter and one receiver.

| MODULATION MODE | FUNCTION |
|-----------------|----------|
| 802.11b | 1TX/1RX |
| 802.11g | 1TX/1RX |
| 802.11n (HT20) | 1TX/1RX |
| BT-LE | 1TX/1RX |

2. For a more detailed features description, please refer to the manufacturer's specifications or the user's manual.
3. For the test results, the EUT had been tested with all conditions. But only the worst case was shown in test report.
4. Please refer to the EUT photo document (Reference No.: 2304WDG0057) for detailed product photo.
5. Adapter as an optional item, can be shipped with or without. The EUT was powered by the following adapter:

| Adapter | |
|---------|------------------------|
| BRAND: | N/A |
| MODEL: | TPA-46B050100UU |
| INPUT: | 100-240V~50/60Hz, 0.2A |
| OUTPUT: | 5V, 1A |

3.2 DESCRIPTION OF TEST MODES

11 channels are provided for 802.11b, 802.11g and 802.11n(HT20):

| CHANNEL | FREQUENCY | CHANNEL | FREQUENCY |
|---------|-----------|---------|-----------|
| 1 | 2412 MHz | 7 | 2442 MHz |
| 2 | 2417 MHz | 8 | 2447 MHz |
| 3 | 2422 MHz | 9 | 2452 MHz |
| 4 | 2427 MHz | 10 | 2457 MHz |
| 5 | 2432 MHz | 11 | 2462 MHz |
| 6 | 2437 MHz | | |

40 channels are provided for BT-LE(GFSK):

| CHANNEL | FREQ. (MHZ) | CHANNEL | FREQ. (MHZ) | CHANNEL | FREQ. (MHZ) | CHANNEL | FREQ. (MHZ) |
|---------|----------------|---------|----------------|---------|----------------|---------|----------------|
| 0 | 2402 | 10 | 2422 | 20 | 2442 | 30 | 2462 |
| 1 | 2404 | 11 | 2424 | 21 | 2444 | 31 | 2464 |
| 2 | 2406 | 12 | 2426 | 22 | 2446 | 32 | 2466 |
| 3 | 2408 | 13 | 2428 | 23 | 2448 | 33 | 2468 |
| 4 | 2410 | 14 | 2430 | 24 | 2450 | 34 | 2470 |
| 5 | 2412 | 15 | 2432 | 25 | 2452 | 35 | 2472 |
| 6 | 2414 | 16 | 2434 | 26 | 2454 | 36 | 2474 |
| 7 | 2416 | 17 | 2436 | 27 | 2456 | 37 | 2476 |
| 8 | 2418 | 18 | 2438 | 28 | 2458 | 38 | 2478 |
| 9 | 2420 | 19 | 2440 | 29 | 2460 | 39 | 2480 |

3.2.1 CONFIGURATION OF SYSTEM UNDER TEST

Please see section 5 photographs of the test configuration for reference.

3.2.2 TEST MODE APPLICABILITY AND TESTED CHANNEL DETAIL

Pre-Scan has been conducted to determine the worst-case mode from all possible combinations between available modulations, data rates, XYZ axis, power supply voltage range and antenna ports. The worst case was found when positioned on X axis for radiated emission. Following test modes were selected for the final test, and the final worst case is marked in boldface and recorded in the report:

| EUT CONFIGURE MODE | APPLICABLE TO | | | | MODE |
|--------------------|---------------|-------|-----|------|---------------------------|
| | RE<1G | RE≥1G | PLC | APCM | |
| A | √ | √ | √ | √ | Powered by Adapter |

Where **RE<1G**: Radiated Emission below 1GHz **RE≥1G**: Radiated Emission above 1GHz
PLC: Power Line Conducted Emission **APCM**: Antenna Port Conducted Measurement

POWER LINE CONDUCTED EMISSION TEST:

- Pre-Scan has been conducted to determine the worst-case mode from all possible combinations between available modulations, data rates and antenna ports (if EUT with antenna diversity architecture).
- Following channel(s) was (were) selected for the final test as listed below.

| EUT CONFIGURE MODE | TESTED CONDITION |
|--------------------|---------------------------|
| - | BT Link+ WIFI (2.4G) Link |

RADIATED EMISSION TEST (BELOW 1GHz):

- Pre-Scan has been conducted to determine the worst-case mode from all possible combinations between available modulations, data rates, XYZ axis and antenna ports (if EUT with antenna diversity architecture).
- Following channel(s) was (were) selected for the final test as listed below.

| EUT CONFIGURE MODE | MODE | AVAILABLE CHANNEL | TESTED CHANNEL | MODULATION TECHNOLOGY | MODULATION TYPE | DATA RATE (Mbps) |
|--------------------|---------|-------------------|----------------|-----------------------|-----------------|------------------|
| A | 802.11b | 1 to 11 | 1 | DSSS | DBPSK | 6.0 |
| A | BT-LE | 0 to 39 | 39 | DTS | BT-LE | 1.0 |

RADIATED EMISSION TEST (ABOVE 1GHz):

- Pre-Scan has been conducted to determine the worst-case mode from all possible combinations between available modulations, data rates, XYZ axis and antenna ports (if EUT with antenna diversity architecture).
- Following channel(s) was (were) selected for the final test as listed below.

| EUT CONFIGURE MODE | MODE | AVAILABLE CHANNEL | TESTED CHANNEL | MODULATION TECHNOLOGY | MODULATION TYPE | DATA RATE (Mbps) |
|--------------------|--------------|-------------------|----------------|-----------------------|-----------------|------------------|
| A | 802.11b | 1 to 11 | 1, 6, 11 | DSSS | DBPSK | 1.0 |
| A | 802.11g | 1 to 11 | 1, 6, 11 | OFDM | BPSK | 6.0 |
| A | 802.11n HT20 | 1 to 11 | 1, 6, 11 | OFDM | BPSK | 6.5 |
| A | BT-LE | 0 to 39 | 0,19, 39 | DTS | BT-LE | 1.0 |

ANTENNA PORT CONDUCTED MEASUREMENT:

- This item includes all test value of each mode, but only includes spectrum plot of worst value of each mode.
- Pre-Scan has been conducted to determine the worst-case mode from all possible combinations between available modulations, data rates and antenna ports (if EUT with antenna diversity architecture).
- Following channel(s) was (were) selected for the final test as listed below.

| EUT CONFIGURE MODE | MODE | AVAILABLE CHANNEL | TESTED CHANNEL | MODULATION TECHNOLOGY | MODULATION TYPE | DATA RATE (Mbps) |
|--------------------|--------------|-------------------|----------------|-----------------------|-----------------|------------------|
| A | 802.11b | 1 to 11 | 1, 6, 11 | DSSS | DBPSK | 1.0 |
| A | 802.11g | 1 to 11 | 1, 6, 11 | OFDM | BPSK | 6.0 |
| A | 802.11n HT20 | 1 to 11 | 1, 6, 11 | OFDM | BPSK | 6.5 |
| A | BT-LE | 0 to 39 | 0,19, 39 | DTS | BT-LE | 1.0 |

TEST CONDITION:

| APPLICABLE TO | ENVIRONMENTAL CONDITIONS | TEST VOLTAGE(Adapter) | TESTED BY |
|---------------|--------------------------|-----------------------|-------------|
| RE<1G | 26deg. C, 50%RH | 120V/60Hz | Cheng Zhong |
| RE≥1G | 26deg. C, 50%RH | 120V/60Hz | Cheng Zhong |
| PLC | 25deg. C, 60%RH | 120V/60Hz | Yang |
| APCM | 20deg. C, 55%RH | 120V/60Hz | Sen He |

3.3 GENERAL DESCRIPTION OF APPLIED STANDARDS

The EUT is a RF Product. According to the specifications of the manufacturer, it must comply with the requirements of the following standards:

FCC Part 15, Subpart C, Section 15.247

KDB 558074 D01 15.247 Meas Guidance v05r02

ANSI C63.10-2013

All test items have been performed and recorded as per the above standards.

3.4 DESCRIPTION OF SUPPORT UNITS

The EUT has been tested as an independent unit together with other necessary accessories or support units. The following support units or accessories were used to form a representative test configuration during the tests.

| NO. | PRODUCT | BRAND | MODEL NO. | SERIAL NO. | FCC ID |
|-----|----------|-------|-----------|------------|--------|
| 1 | Notebook | DELL | E6420 | 9H12FS1 | N/A |

| NO. | DESCRIPTION OF THE ABOVE SUPPORT UNITS |
|-----|--|
| 1 | AC Line: Unshielded, Detachable 1.0m; DC Line: Unshielded, Detachable 2.0m |

3.5 CONFIGURATION OF SYSTEM UNDER TEST

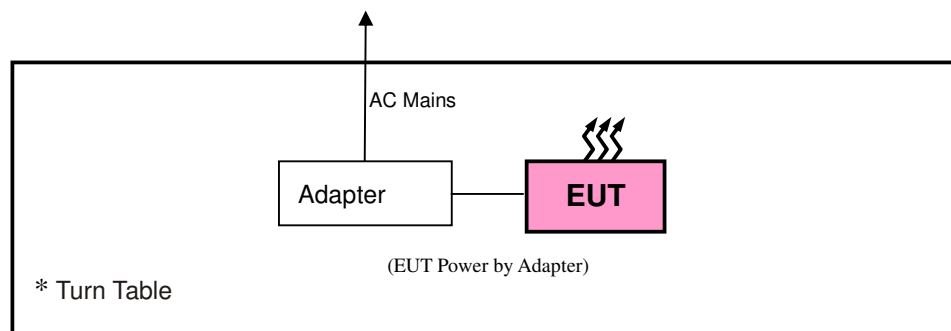

3.6 DUTY CYCLE OF TESET SIGNAL

| Test Mode | On Time (ms) | Period (ms) | Duty Cycle (%) | Duty factor (dB) | 1/T Min. VBW (KHz) | VBW Setting |
|----------------|--------------|-------------|----------------|------------------|--------------------|-------------|
| 802.11b | 1.302 | 1.397 | 93.2 | 0.31 | 0.768 | 1KHz |
| 802.11g | 0.248 | 0.366 | 67.8 | 1.69 | 4.032 | 5KHz |
| 802.11n (HT20) | 0.228 | 0.363 | 62.8 | 2.02 | 4.386 | 5KHz |
| BLE | 0.393 | 0.625 | 62.9 | 2.015 | 2.545 | 3KHz |

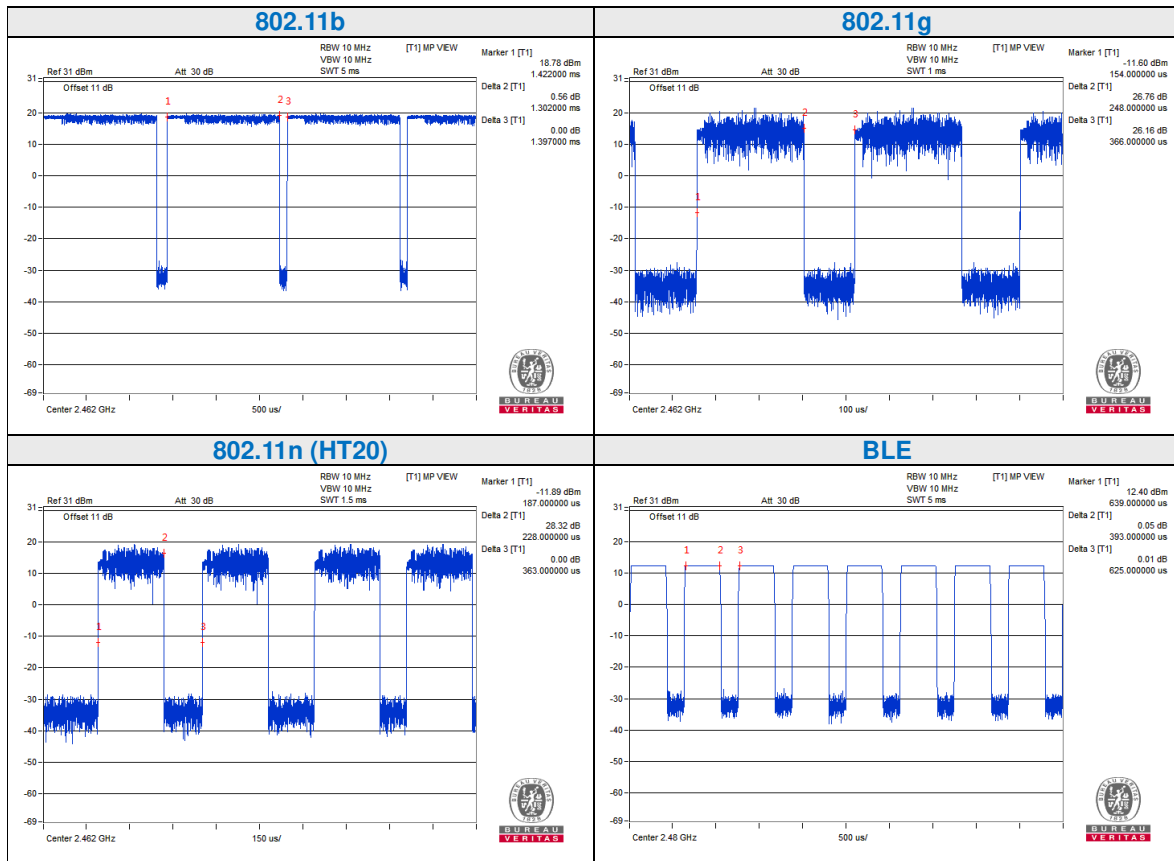

4 TEST TYPES AND RESULTS

4.1 CONDUCTED EMISSION MEASUREMENT

4.1.1 LIMITS OF CONDUCTED EMISSION MEASUREMENT

| FREQUENCY OF EMISSION (MHz) | CONDUCTED LIMIT (dB μ V) | |
|-----------------------------|------------------------------|----------|
| | Quasi-peak | Average |
| 0.15 ~ 0.5 | 66 to 56 | 56 to 46 |
| 0.5 ~ 5 | 56 | 46 |
| 5 ~ 30 | 60 | 50 |

- NOTE:**
1. The lower limit shall apply at the transition frequencies.
 2. The limit decreases in line with the logarithm of the frequency in the range of 0.15 to 0.50MHz.
 3. All emanations from a class A/B digital device or system, including any network of conductors and apparatus connected thereto, shall not exceed the level of field strengths specified above.

4.1.2 TEST INSTRUMENTS

| Equipment | Manufacturer | Model No. | Serial No. | Next Cal. |
|--------------------------|---------------|-----------------|-------------|-------------|
| EMI Test Receiver | Rohde&Schwarz | ESR7 | 101494 | Jan. 10,24 |
| Artificial Mains Network | Rohde&Schwarz | ENV216 | 101173 | Jan. 11,24 |
| Artificial Mains Network | Rohde&Schwarz | ESH3-Z5 | 100317 | Jan. 10,24 |
| Voltage probe | SCHWARZBECK | TK 9421 | TK 9421-176 | Jul. 27, 23 |
| Coaxial RF Cable | SUHNER | RG 223/U-CE | C2310066DG | Jul. 24, 23 |
| Test software | ADT | ADT_Cond_V7.3.7 | N/A | N/A |

- NOTE:**
1. The test was performed in shielded room 553.
 2. The calibration interval of the above test instruments is 12 months. And the calibrations are traceable to CEPREI/CHINA, GRGT/CHINA and NIM/CHINA.

4.1.3 TEST PROCEDURES

- a. The EUT was placed 0.4 meters from the conducting wall of the shielded room with EUT being connected to the power mains through a line impedance stabilization network (LISN). Other support units were connected to the power mains through another LISN. The two LISNs provide 50 ohm/ 50uH of coupling impedance for the measuring instrument.
- b. Both lines of the power mains connected to the EUT were checked for maximum conducted interference.
- c. The frequency range from 150kHz to 30MHz was searched. Emission levels under (Limit - 20dB) were not recorded.

NOTE: All modes of operation were investigated and the worst-case emissions are reported.

4.1.4 DEVIATION FROM TEST STANDARD

No deviation.

4.1.5 TEST SETUP

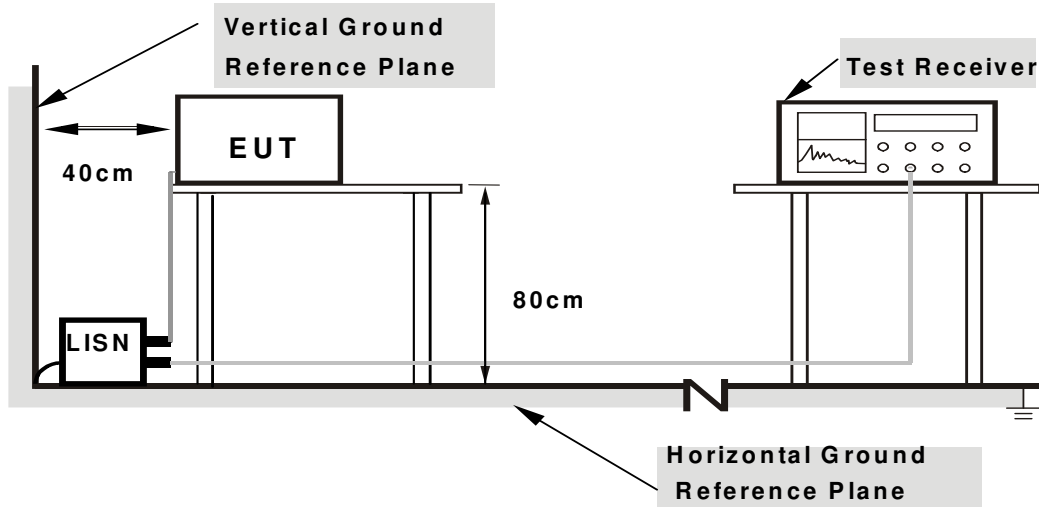

- Note: 1.Support units were connected to second LISN.**
2.Both of LISNs (AMN) are 80 cm from EUT and at least 80 from other units and other metal planes

For the actual test configuration, please refer to the attached file (Test Setup Photo).

4.1.6 EUT OPERATING CONDITIONS

- a. Turned on the power and connected of all equipment.
- b. EUT was operated according to the type used was description in manufacturer's specifications or the User's Manual.

4.1.7 TEST RESULTS

CONDUCTED WORST-CASE DATA: BT+WIFI

| | | | |
|--------------|------|----------------------|------|
| PHASE | Line | 6dB BANDWIDTH | 9kHz |
|--------------|------|----------------------|------|

| No | Freq. [MHz] | Corr. Factor (dB) | Reading Value [dB (uV)] | | Emission Level [dB (uV)] | | Limit [dB (uV)] | | Margin (dB) | |
|----|-------------|-------------------|-------------------------|-------|--------------------------|-------|-----------------|-------|-------------|--------|
| | | | Q.P. | AV. | Q.P. | AV. | Q.P. | AV. | Q.P. | AV. |
| 1 | 0.51834 | 10.21 | 38.98 | 31.89 | 49.19 | 42.10 | 56.00 | 46.00 | -6.81 | -3.90 |
| 2 | 1.18725 | 10.24 | 41.30 | 28.60 | 51.54 | 38.84 | 56.00 | 46.00 | -4.46 | -7.16 |
| 3 | 1.31295 | 10.25 | 35.20 | 24.20 | 45.45 | 34.45 | 56.00 | 46.00 | -10.55 | -11.55 |
| 4 | 2.65650 | 10.29 | 31.27 | 21.58 | 41.56 | 31.87 | 56.00 | 46.00 | -14.44 | -14.13 |
| 5 | 3.46650 | 10.33 | 29.17 | 19.34 | 39.50 | 29.67 | 56.00 | 46.00 | -16.50 | -16.33 |
| 6 | 5.08650 | 10.42 | 29.61 | 19.82 | 40.03 | 30.24 | 60.00 | 50.00 | -19.97 | -19.76 |

- REMARKS:**
1. Q.P. and AV. are abbreviations of quasi-peak and average individually.
 2. "-": The Quasi-peak reading value also meets average limit and measurement with the average detector is unnecessary.
 3. The emission levels of other frequencies were very low against the limit.
 4. Margin value = Emission level - Limit value
 5. Correction factor = Insertion loss + Cable loss
 6. Emission Level = Correction Factor + Reading Value.

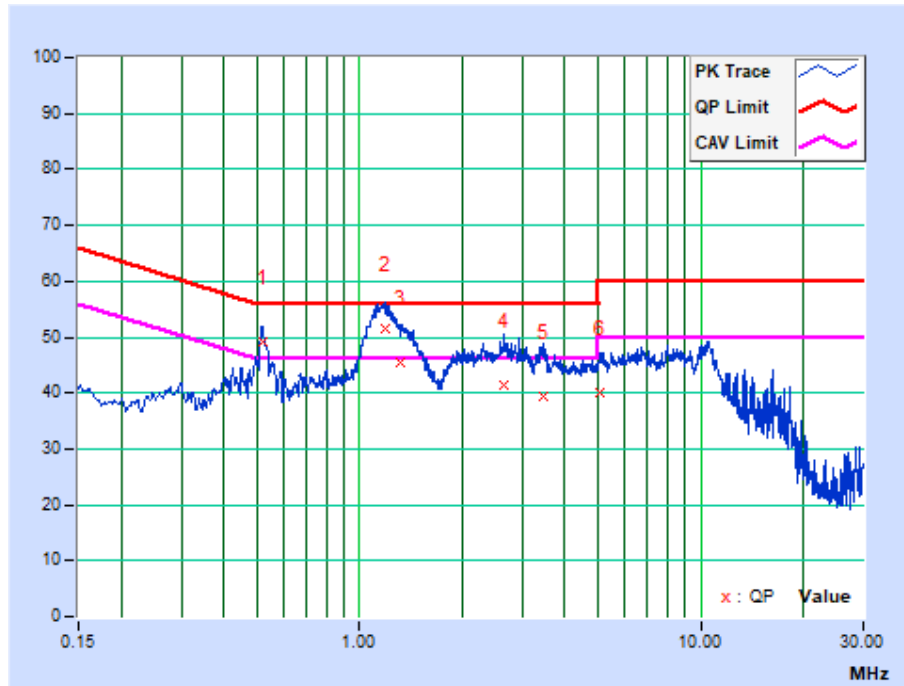

| | | | |
|--------------|---------|----------------------|------|
| PHASE | Neutral | 6dB BANDWIDTH | 9kHz |
|--------------|---------|----------------------|------|

| No | Freq. [MHz] | Corr. Factor (dB) | Reading Value [dB (uV)] | | Emission Level [dB (uV)] | | Limit [dB (uV)] | | Margin (dB) | |
|----|-------------|-------------------|-------------------------|-------|--------------------------|-------|-----------------|-------|-------------|--------|
| | | | Q.P. | AV. | Q.P. | AV. | Q.P. | AV. | Q.P. | AV. |
| 1 | 0.51425 | 10.17 | 34.70 | 26.60 | 44.87 | 36.77 | 56.00 | 46.00 | -11.13 | -9.23 |
| 2 | 1.17375 | 10.21 | 36.49 | 24.23 | 46.70 | 34.44 | 56.00 | 46.00 | -9.30 | -11.56 |
| 3 | 1.43248 | 10.22 | 31.04 | 18.59 | 41.26 | 28.81 | 56.00 | 46.00 | -14.74 | -17.19 |
| 4 | 2.75325 | 10.28 | 26.33 | 14.40 | 36.61 | 24.68 | 56.00 | 46.00 | -19.39 | -21.32 |
| 5 | 4.99425 | 10.40 | 25.74 | 12.93 | 36.14 | 23.33 | 56.00 | 46.00 | -19.86 | -22.67 |
| 6 | 10.79250 | 10.91 | 28.84 | 20.60 | 39.75 | 31.51 | 60.00 | 50.00 | -20.25 | -18.49 |

- REMARKS:**
1. Q.P. and AV. are abbreviations of quasi-peak and average individually.
 2. "-": The Quasi-peak reading value also meets average limit and measurement with the average detector is unnecessary.
 3. The emission levels of other frequencies were very low against the limit.
 4. Margin value = Emission level - Limit value
 5. Correction factor = Insertion loss + Cable loss
 6. Emission Level = Correction Factor + Reading Value.

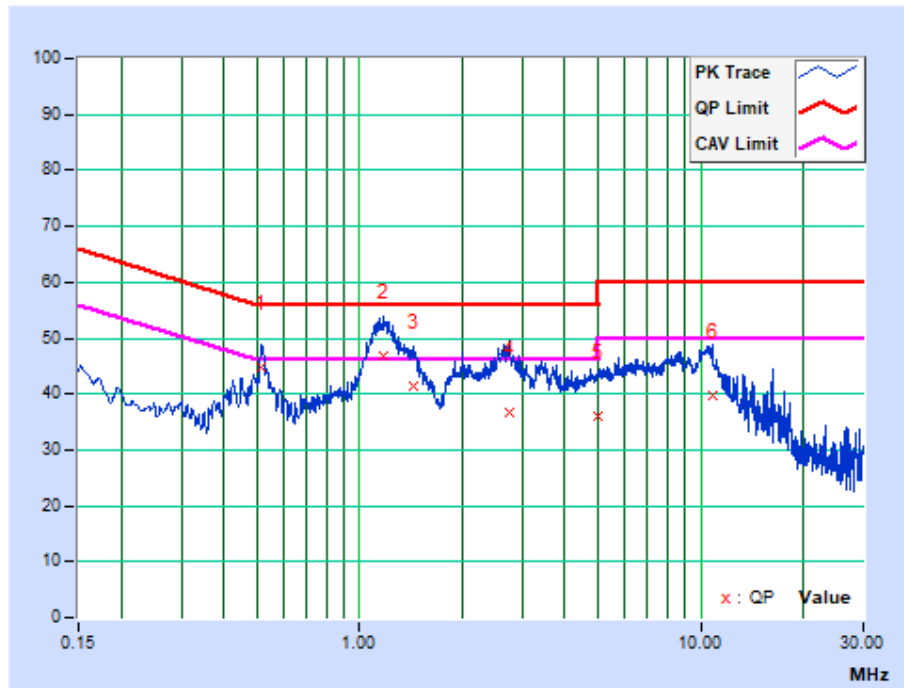

4.2 RADIATED EMISSION MEASUREMENT

4.2.1 LIMITS OF RADIATED EMISSION MEASUREMENT

Radiated emissions which fall in the restricted bands, as defined in Section 15.205(a), must also comply with the radiated emission limits specified in Section 15.209(a).

| FREQUENCIES (MHz) | FIELD STRENGTH (microvolts/meter) | MEASUREMENT DISTANCE (meters) |
|----------------------|--------------------------------------|----------------------------------|
| 0.009 ~ 0.490 | 2400/F(kHz) | 300 |
| 0.490 ~ 1.705 | 24000/F(kHz) | 30 |
| 1.705 ~ 30.0 | 30 | 30 |
| 30 ~ 88 | 100 | 3 |
| 88 ~ 216 | 150 | 3 |
| 216 ~ 960 | 200 | 3 |
| Above 960 | 500 | 3 |

NOTE:

1. The lower limit shall apply at the transition frequencies.
2. Emission level (dBuV/m) = 20 log Emission level (uV/m).
3. As shown in 15.35(b), for frequencies above 1000MHz, the field strength limits are based on average detector, however, the peak field strength of any emission shall not exceed the maximum permitted average limits, specified above by more than 20dB under any condition of modulation.

4.2.2 TEST INSTRUMENTS

| Equipment | Manufacturer | Model No. | Serial No. | Next Cal. |
|-------------------------------------|---------------|--------------------------|-------------|-------------|
| EMI Test Receiver | Rohde&Schwarz | ESU40 | 100449 | Jan. 10, 24 |
| Signal and Spectrum Analyzer | Rohde&Schwarz | FSV7 | 102331 | May. 09, 24 |
| Active Loop Antenna (9KHz -30MHz) | SCHWARZBECK | FMZB 1519B | 1519B-045 | Apr. 27, 24 |
| Amplifier (9KHz -1GHz) | Burgeon | BPA-530 | 100210 | Mar. 06, 24 |
| Trilog-Broadband Antenna(20M-2G) | SCHWARZBECK | VULB 9168 | 01282 | Aug. 21, 23 |
| Horn Antenna (1GHz -18GHz) | ETS -Lindgren | 3117 | 00062558 | Apr. 27, 24 |
| Horn Antenna (18GHz -40GHz) | SCHWARZBECK | BBHA 9170 | BBHA9170147 | Apr. 28, 24 |
| 3m Semi-anechoic Chamber | ETS-LINDGREN | 9m*6m*6m | NSEMC003 | May 22, 24 |
| Test Software | ADT | ADT_Radiated_V7.6.15.9.2 | N/A | N/A |
| Broadband Preamplifier (1GHz~18GHz) | SCHWARZBECK | BBV9718 | 305 | Apr. 26, 24 |
| Pre-Amplifier (18GHz-40GHz) | EMCI | EMC 184045 | 980102 | Jan. 16, 24 |
| BLUETOOTH TESTER | Rohde&Schwarz | CBT32 | 100811 | N/A |

NOTE:

1. The test was performed in 966 Chamber.
2. The calibration interval of the above test instruments is 12 months and the calibrations are traceable to CEPREI/CHINA, GRGT/CHINA and NIM/CHINA.
3. The horn antenna is used only for the measurement of emission frequency above 1GHz if tested.
4. The FCC Site Registration No. is 749762.

4.2.3 TEST PROCEDURES

- a. The EUT was placed on the top of a rotating table 1.5 meters (above 1GHz) and 0.8 meters (below 1GHz) above the ground at a 3 meters semi-anechoic chamber. The table was rotated 360 degrees to determine the position of the highest radiation.
- b. The EUT was set 3 meters away from the interference-receiving antenna, which was mounted on the top of a variable-height antenna tower.
- c. For below 1GHz was used bilog antenna, and above 1GHz was used horn antenna, and its height is varied from one meter to four meters above the ground to determine the maximum value of the field strength. Both horizontal and vertical polarizations of the antenna are set to make the measurement.
- d. For each suspected emission, the EUT was arranged to its worst case and then the antenna was tuned to heights from 1 meter to 4 meters and the rotatable table was turned from 0 degrees to 360 degrees to find the maximum reading.
- e. The test-receiver system was set to Peak Detect Function and Specified Bandwidth with Maximum Hold Mode.
- f. For below 30MHz, a loop antenna with its vertical plane is place 3m from the EUT and rotated about its vertical axis for maximum response at each azimuth about the EUT, the lowest height of the magnetic antenna shall be 1.3m above the ground.
- a. During the test, each emission was maximized by: having the EUT continuously working, investigated all operating modes, rotated about all 3 axis (X, Y & Z) and considered typical configuration to obtain worst position, manipulating interconnecting cables, For battery operated equipment, the equipment tests shall be perform using fresh batteries. The turntable was rotated to maximize the emission level.

NOTE:

1. The resolution bandwidth and video bandwidth of test receiver/spectrum analyzer is 120kHz for Quasi-peak detection at frequency below 1GHz.
2. The resolution bandwidth of test receiver/spectrum analyzer is 1MHz and video bandwidth is 3MHz for Peak detection at frequency above 1GHz.
3. The resolution bandwidth of test receiver/spectrum analyzer is 1MHz and the video bandwidth is $\geq 1/T$ (Duty cycle < 98%) or 10Hz(Duty cycle > 98%) for Average detection (AV) at frequency above 1GHz.
4. All modes of operation were investigated and the worst-case emissions are reported.
5. The testing of the EUT was performed on all 3 orthogonal axes, the worst-case test configuration was reported on the file test setup photo.



4.2.4 DEVIATION FROM TEST STANDARD

No deviation.

4.2.5 TEST SETUP

Below 30MHz test setup

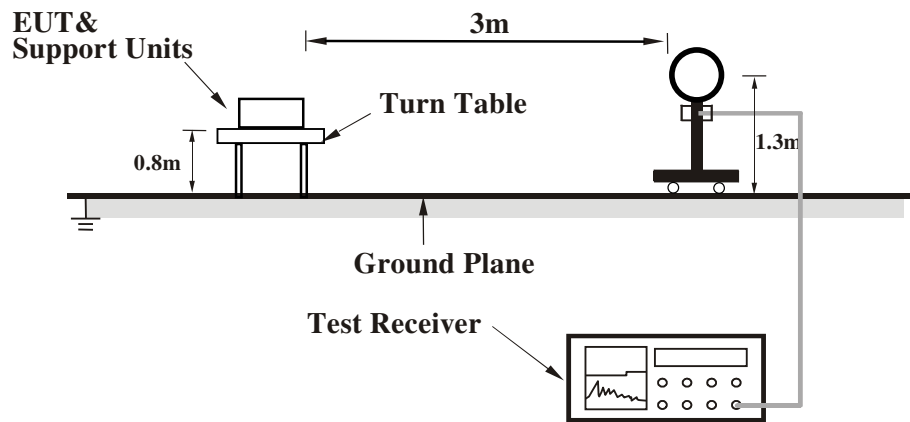

Below 1GHz test setup

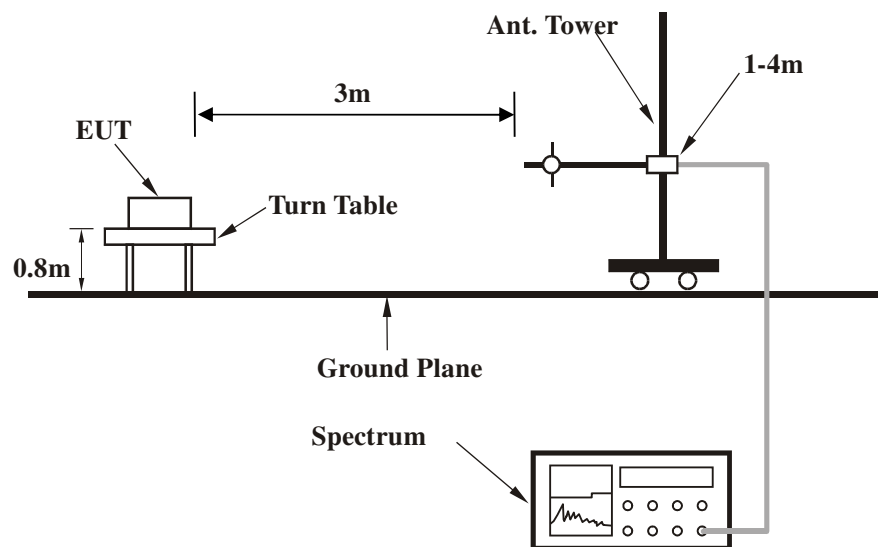

Note: For the actual test configuration, please refer to the attached file (Test Setup Photo).

Above 1GHz test setup

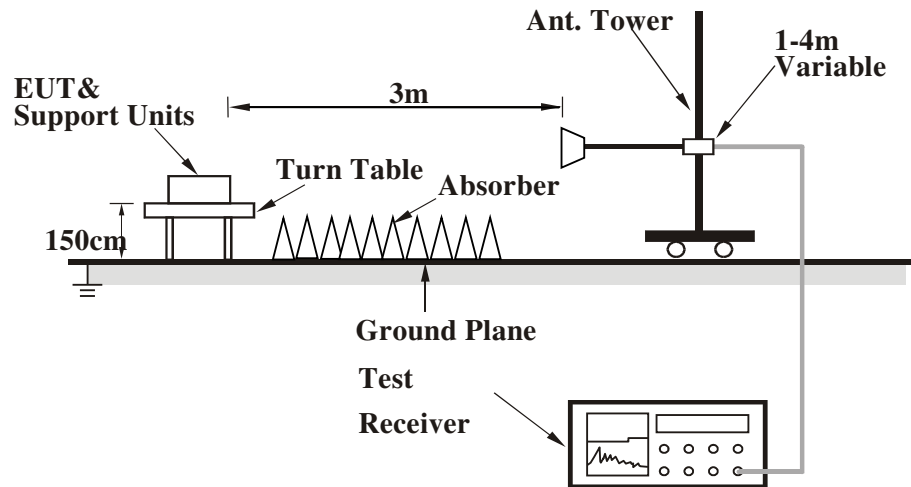

Note: For the actual test configuration, please refer to the attached file (Test Setup Photo).

4.2.6 EUT OPERATING CONDITIONS

- Set the EUT under full load condition and placed them on a testing table.
- Set the transmitter part of EUT under transmission condition continuously at specific channel frequency.
- The necessary accessories enable the EUT in full functions.

4.2.7 TEST RESULTS

BELOW 1GHz WORST-CASE DATA:

802.11b

| | | | |
|------------------------|--------------|--------------------------|-----------------|
| CHANNEL | TX Channel 1 | DETECTOR FUNCTION | Quasi-Peak (QP) |
| FREQUENCY RANGE | 9KHz ~ 1GHz | | |

| ANTENNA POLARITY & TEST DISTANCE: HORIZONTAL AT 3 M | | | | | | | | |
|---|-------------|-------------------------|----------------|-------------|--------------------|----------------------|------------------|--------------------------|
| NO. | FREQ. (MHz) | EMISSION LEVEL (dBuV/m) | LIMIT (dBuV/m) | MARGIN (dB) | ANTENNA HEIGHT (m) | TABLE ANGLE (Degree) | RAW VALUE (dBuV) | CORRECTION FACTOR (dB/m) |
| 1 | 34.66 | 16.83 QP | 40.00 | -23.17 | 2.50 H | 235 | 34.18 | -17.35 |
| 2 | 117.05 | 22.23 QP | 43.50 | -21.27 | 2.50 H | 98 | 40.25 | -18.02 |
| 3 | 194.78 | 31.08 QP | 43.50 | -12.42 | 2.50 H | 114 | 48.72 | -17.64 |
| 4 | 476.14 | 32.80 QP | 46.00 | -13.20 | 2.50 H | 216 | 42.25 | -9.45 |
| 5 | 533.65 | 26.29 QP | 46.00 | -19.71 | 2.50 H | 59 | 34.33 | -8.04 |
| 6 | 665.79 | 30.44 QP | 46.00 | -15.56 | 2.50 H | 301 | 35.64 | -5.20 |

REMARKS:

1. Emission level (dBuV/m) = Raw Value (dBuV) + Correction Factor (dB/m).
2. Correction Factor (dB/m) = Antenna Factor (dB/m) + Cable Factor (dB).
3. The emission levels of other frequencies were less than 20dB margin against the limit.
4. Margin value = Emission level – Limit value.

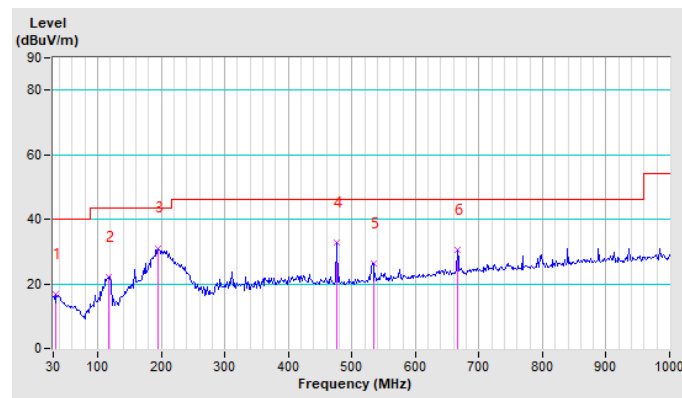

| | | | |
|------------------------|--------------|------------------------------|-----------------|
| CHANNEL | TX Channel 1 | DETECTOR FUNCTION | Quasi-Peak (QP) |
| FREQUENCY RANGE | 9KHz ~ 1GHz | | |

| ANTENNA POLARITY & TEST DISTANCE: VERTICAL AT 3 M | | | | | | | | |
|---|----------------|-------------------------------|-------------------|----------------|--------------------------|----------------------------|------------------------|--------------------------------|
| NO. | FREQ. (MHz) | EMISSION LEVEL (dBuV/m) | LIMIT (dBuV/m) | MARGIN (dB) | ANTENNA HEIGHT (m) | TABLE ANGLE (Degree) | RAW VALUE (dBuV) | CORRECTION FACTOR (dB/m) |
| 1 | 37.77 | 15.76 QP | 40.00 | -24.24 | 1.00 V | 104 | 32.57 | -16.81 |
| 2 | 120.16 | 15.96 QP | 43.50 | -27.54 | 1.00 V | 89 | 33.74 | -17.78 |
| 3 | 187.00 | 24.83 QP | 43.50 | -18.67 | 1.00 V | 74 | 42.04 | -17.21 |
| 4 | 476.14 | 27.44 QP | 46.00 | -18.56 | 1.00 V | 57 | 36.89 | -9.45 |
| 5 | 532.10 | 30.75 QP | 46.00 | -15.25 | 1.00 V | 32 | 38.83 | -8.08 |
| 6 | 636.25 | 23.13 QP | 46.00 | -22.87 | 1.00 V | 18 | 28.98 | -5.85 |

REMARKS:

1. Emission level (dBuV/m) = Raw Value (dBuV) + Correction Factor (dB/m).
2. Correction Factor (dB/m) = Antenna Factor (dB/m) + Cable Factor (dB).
3. The emission levels of other frequencies were less than 20dB margin against the limit.
4. Margin value = Emission level – Limit value.

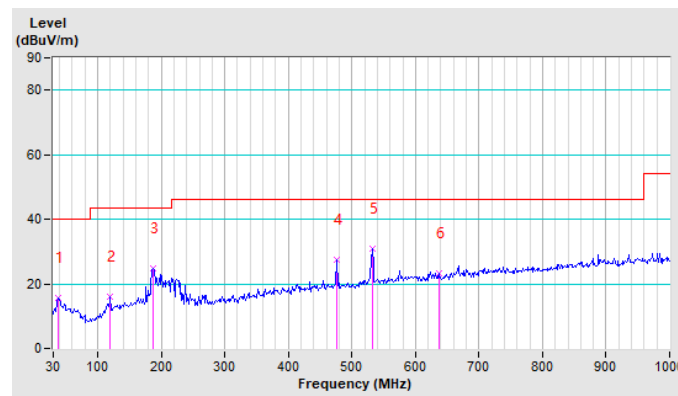



ABOVE 1GHz DATA

802.11b

| | | | |
|-----------------|--------------|----------------------|--------------|
| CHANNEL | TX Channel 1 | DETECTOR FUNCTION | Peak (PK) |
| FREQUENCY RANGE | 1GHz ~ 25GHz | | Average (AV) |

ANTENNA POLARITY & TEST DISTANCE: HORIZONTAL AT 3 M

| NO. | FREQ. (MHz) | EMISSION LEVEL (dBuV/m) | LIMIT (dBuV/m) | MARGIN (dB) | ANTENNA HEIGHT (m) | TABLE ANGLE (Degree) | RAW VALUE (dBuV) | CORRECTION FACTOR (dB/m) |
|-----|-------------|-------------------------|----------------|-------------|--------------------|----------------------|------------------|--------------------------|
| 1 | 2390.00 | 55.97 PK | 74.00 | -18.03 | 1.40 H | 343 | 53.28 | 2.69 |
| 2 | 2390.00 | 40.15 AV | 54.00 | -13.85 | 1.40 H | 343 | 37.46 | 2.69 |
| 3 | *2412.00 | 112.81 PK | | | 1.40 H | 343 | 110.04 | 2.77 |
| 4 | *2412.00 | 106.24 AV | | | 1.40 H | 343 | 103.47 | 2.77 |
| 5 | 4824.00 | 49.28 PK | 74.00 | -24.72 | 2.52 H | 360 | 40.94 | 8.34 |
| 6 | 4824.00 | 41.29 AV | 54.00 | -12.71 | 2.52 H | 360 | 32.95 | 8.34 |
| 7 | #7236.00 | 52.35 PK | 74.00 | -21.65 | 1.06 H | 89 | 42.80 | 9.55 |
| 8 | #7236.00 | 40.28 AV | 54.00 | -13.72 | 1.06 H | 89 | 30.73 | 9.55 |

ANTENNA POLARITY & TEST DISTANCE: VERTICAL AT 3 M

| NO. | FREQ. (MHz) | EMISSION LEVEL (dBuV/m) | LIMIT (dBuV/m) | MARGIN (dB) | ANTENNA HEIGHT (m) | TABLE ANGLE (Degree) | RAW VALUE (dBuV) | CORRECTION FACTOR (dB/m) |
|-----|-------------|-------------------------|----------------|-------------|--------------------|----------------------|------------------|--------------------------|
| 1 | 2390.00 | 47.88 PK | 74.00 | -26.12 | 1.00 V | 338 | 45.19 | 2.69 |
| 2 | 2390.00 | 35.22 AV | 54.00 | -18.78 | 1.00 V | 338 | 32.53 | 2.69 |
| 3 | *2412.00 | 104.22 PK | | | 1.00 V | 338 | 101.45 | 2.77 |
| 4 | *2412.00 | 97.04 AV | | | 1.00 V | 338 | 94.27 | 2.77 |
| 5 | 4824.00 | 51.28 PK | 74.00 | -22.72 | 2.00 V | 95 | 42.94 | 8.34 |
| 6 | 4824.00 | 40.29 AV | 54.00 | -13.71 | 2.00 V | 95 | 31.95 | 8.34 |
| 7 | #7236.00 | 52.39 PK | 74.00 | -21.61 | 1.65 V | 95 | 42.84 | 9.55 |
| 8 | #7236.00 | 43.00 AV | 54.00 | -11.00 | 1.65 V | 95 | 33.45 | 9.55 |

REMARKS:

1. Emission level (dBuV/m) = Raw Value (dBuV) + Correction Factor (dB/m).
2. Correction Factor (dB/m) = Antenna Factor (dB/m) + Cable Factor (dB).
3. The emission levels of other frequencies were less than 20dB margin against the limit.
4. Margin value = Emission level – Limit value.
5. " * ": Fundamental frequency.
6. " # ": The radiated frequency is out of the restricted band.

| | | | |
|------------------------|--------------|------------------------------|--------------|
| CHANNEL | TX Channel 6 | DETECTOR FUNCTION | Peak (PK) |
| FREQUENCY RANGE | 1GHz ~ 25GHz | | Average (AV) |

ANTENNA POLARITY & TEST DISTANCE: HORIZONTAL AT 3 M

| NO. | FREQ. (MHz) | EMISSION LEVEL (dBuV/m) | LIMIT (dBuV/m) | MARGIN (dB) | ANTENNA HEIGHT (m) | TABLE ANGLE (Degree) | RAW VALUE (dBuV) | CORRECTION FACTOR (dB/m) |
|-----|----------------|-------------------------------|-------------------|----------------|--------------------------|----------------------------|------------------------|--------------------------------|
| 1 | *2437.00 | 114.81 PK | | | 1.54 H | 341 | 111.97 | 2.84 |
| 2 | *2437.00 | 106.19 AV | | | 1.54 H | 341 | 103.35 | 2.84 |
| 3 | 4874.00 | 49.65 PK | 74.00 | -24.35 | 1.65 H | 90 | 40.96 | 8.69 |
| 4 | 4874.00 | 38.00 AV | 54.00 | -16.00 | 1.65 H | 90 | 29.31 | 8.69 |
| 5 | 7311.00 | 53.20 PK | 74.00 | -20.80 | 1.56 H | 34 | 43.61 | 9.59 |
| 6 | 7311.00 | 40.39 AV | 54.00 | -13.61 | 1.56 H | 34 | 30.80 | 9.59 |

ANTENNA POLARITY & TEST DISTANCE: VERTICAL AT 3 M

| NO. | FREQ. (MHz) | EMISSION LEVEL (dBuV/m) | LIMIT (dBuV/m) | MARGIN (dB) | ANTENNA HEIGHT (m) | TABLE ANGLE (Degree) | RAW VALUE (dBuV) | CORRECTION FACTOR (dB/m) |
|-----|----------------|-------------------------------|-------------------|----------------|--------------------------|----------------------------|------------------------|--------------------------------|
| 1 | *2437.00 | 105.25 PK | | | 1.00 V | 95 | 102.41 | 2.84 |
| 2 | *2437.00 | 97.68 AV | | | 1.00 V | 95 | 94.84 | 2.84 |
| 3 | 4874.00 | 51.29 PK | 74.00 | -22.71 | 1.65 V | 95 | 42.60 | 8.69 |
| 4 | 4874.00 | 40.32 AV | 54.00 | -13.68 | 1.65 V | 95 | 31.63 | 8.69 |
| 5 | 7311.00 | 52.39 PK | 74.00 | -21.61 | 1.65 V | 256 | 42.80 | 9.59 |
| 6 | 7311.00 | 40.29 AV | 54.00 | -13.71 | 1.65 V | 256 | 30.70 | 9.59 |

REMARKS:

1. Emission level (dBuV/m) = Raw Value (dBuV) + Correction Factor (dB/m).
2. Correction Factor (dB/m) = Antenna Factor (dB/m) + Cable Factor (dB).
3. The emission levels of other frequencies were less than 20dB margin against the limit.
4. Margin value = Emission level – Limit value.
5. " * " : Fundamental frequency.

| | | | |
|------------------------|---------------|------------------------------|--------------|
| CHANNEL | TX Channel 11 | DETECTOR FUNCTION | Peak (PK) |
| FREQUENCY RANGE | 1GHz ~ 25GHz | | Average (AV) |

| ANTENNA POLARITY & TEST DISTANCE: HORIZONTAL AT 3 M | | | | | | | | |
|---|----------------|-------------------------------|-------------------|----------------|--------------------------|----------------------------|------------------------|--------------------------------|
| NO. | FREQ. (MHz) | EMISSION LEVEL (dBuV/m) | LIMIT (dBuV/m) | MARGIN (dB) | ANTENNA HEIGHT (m) | TABLE ANGLE (Degree) | RAW VALUE (dBuV) | CORRECTION FACTOR (dB/m) |
| 1 | *2462.00 | 114.41 PK | | | 1.70 H | 340 | 111.49 | 2.92 |
| 2 | *2462.00 | 106.53 AV | | | 1.70 H | 340 | 103.61 | 2.92 |
| 3 | 2483.50 | 63.18 PK | 74.00 | -10.82 | 1.70 H | 340 | 60.20 | 2.98 |
| 4 | 2483.50 | 41.48 AV | 54.00 | -12.52 | 1.70 H | 340 | 38.50 | 2.98 |
| 5 | 4924.00 | 51.29 PK | 74.00 | -22.71 | 1.62 H | 96 | 42.24 | 9.05 |
| 6 | 4924.00 | 40.28 AV | 54.00 | -13.72 | 1.62 H | 96 | 31.23 | 9.05 |
| 7 | 7386.00 | 51.29 PK | 74.00 | -22.71 | 1.00 H | 96 | 41.66 | 9.63 |
| 8 | 7386.00 | 41.00 AV | 54.00 | -13.00 | 1.00 H | 96 | 31.37 | 9.63 |
| ANTENNA POLARITY & TEST DISTANCE: VERTICAL AT 3 M | | | | | | | | |
| NO. | FREQ. (MHz) | EMISSION LEVEL (dBuV/m) | LIMIT (dBuV/m) | MARGIN (dB) | ANTENNA HEIGHT (m) | TABLE ANGLE (Degree) | RAW VALUE (dBuV) | CORRECTION FACTOR (dB/m) |
| 1 | *2462.00 | 105.60 PK | | | 1.00 V | 250 | 102.68 | 2.92 |
| 2 | *2462.00 | 96.80 AV | | | 1.00 V | 250 | 93.88 | 2.92 |
| 3 | 2483.50 | 54.00 PK | 74.00 | -20.00 | 1.00 V | 209 | 51.02 | 2.98 |
| 4 | 2483.50 | 41.29 AV | 54.00 | -12.71 | 1.00 V | 209 | 38.31 | 2.98 |
| 5 | 4924.00 | 52.36 PK | 74.00 | -21.64 | 1.95 V | 85 | 43.31 | 9.05 |
| 6 | 4924.00 | 40.25 AV | 54.00 | -13.75 | 1.95 V | 85 | 31.20 | 9.05 |
| 7 | 7386.00 | 51.29 PK | 74.00 | -22.71 | 1.78 V | 81 | 41.66 | 9.63 |
| 8 | 7386.00 | 41.28 AV | 54.00 | -12.72 | 1.78 V | 81 | 31.65 | 9.63 |

REMARKS:

1. Emission level (dBuV/m) = Raw Value (dBuV) + Correction Factor (dB/m).
2. Correction Factor (dB/m) = Antenna Factor (dB/m) + Cable Factor (dB).
3. The emission levels of other frequencies were less than 20dB margin against the limit.
4. Margin value = Emission level – Limit value.
5. " * ": Fundamental frequency.

802.11g

| | | | |
|------------------------|--------------|------------------------------|--------------|
| CHANNEL | TX Channel 1 | DETECTOR FUNCTION | Peak (PK) |
| FREQUENCY RANGE | 1GHz ~ 25GHz | | Average (AV) |

| ANTENNA POLARITY & TEST DISTANCE: HORIZONTAL AT 3 M | | | | | | | | |
|---|----------------|-------------------------------|-------------------|----------------|--------------------------|----------------------------|------------------------|--------------------------------|
| NO. | FREQ. (MHz) | EMISSION LEVEL (dBuV/m) | LIMIT (dBuV/m) | MARGIN (dB) | ANTENNA HEIGHT (m) | TABLE ANGLE (Degree) | RAW VALUE (dBuV) | CORRECTION FACTOR (dB/m) |
| 1 | 2390.00 | 54.83 PK | 74.00 | -19.17 | 1.75 H | 343 | 52.14 | 2.69 |
| 2 | 2390.00 | 44.51 AV | 54.00 | -9.49 | 1.75 H | 343 | 41.82 | 2.69 |
| 3 | *2412.00 | 106.21 PK | | | 1.75 H | 343 | 103.44 | 2.77 |
| 4 | *2412.00 | 97.98 AV | | | 1.75 H | 343 | 95.21 | 2.77 |
| 5 | 4824.00 | 52.19 PK | 74.00 | -21.81 | 1.98 H | 55 | 43.85 | 8.34 |
| 6 | 4824.00 | 41.29 AV | 54.00 | -12.71 | 1.98 H | 55 | 32.95 | 8.34 |
| 7 | #7236.00 | 51.36 PK | 74.00 | -22.64 | 1.95 H | 52 | 41.81 | 9.55 |
| 8 | #7236.00 | 40.32 AV | 54.00 | -13.68 | 1.95 H | 52 | 30.77 | 9.55 |
| ANTENNA POLARITY & TEST DISTANCE: VERTICAL AT 3 M | | | | | | | | |
| NO. | FREQ. (MHz) | EMISSION LEVEL (dBuV/m) | LIMIT (dBuV/m) | MARGIN (dB) | ANTENNA HEIGHT (m) | TABLE ANGLE (Degree) | RAW VALUE (dBuV) | CORRECTION FACTOR (dB/m) |
| 1 | 2390.00 | 47.02 PK | 74.00 | -26.98 | 1.00 V | 248 | 44.33 | 2.69 |
| 2 | 2390.00 | 36.92 AV | 54.00 | -17.08 | 1.00 V | 248 | 34.23 | 2.69 |
| 3 | *2412.00 | 98.30 PK | | | 1.00 V | 248 | 95.53 | 2.77 |
| 4 | *2412.00 | 88.13 AV | | | 1.00 V | 248 | 85.36 | 2.77 |
| 5 | 4824.00 | 51.29 PK | 74.00 | -22.71 | 1.05 V | 322 | 42.95 | 8.34 |
| 6 | 4824.00 | 38.15 AV | 54.00 | -15.85 | 1.05 V | 322 | 29.81 | 8.34 |
| 7 | #7236.00 | 49.25 PK | 74.00 | -24.75 | 1.62 V | 69 | 39.70 | 9.55 |
| 8 | #7236.00 | 40.20 AV | 54.00 | -13.80 | 1.62 V | 69 | 30.65 | 9.55 |

REMARKS:

1. Emission level (dBuV/m) = Raw Value (dBuV) + Correction Factor (dB/m).
2. Correction Factor (dB/m) = Antenna Factor (dB/m) + Cable Factor (dB).
3. The emission levels of other frequencies were less than 20dB margin against the limit.
4. Margin value = Emission level – Limit value.
5. " * ": Fundamental frequency.
6. " # ": The radiated frequency is out of the restricted band.

| | | | |
|------------------------|--------------|------------------------------|--------------|
| CHANNEL | TX Channel 6 | DETECTOR FUNCTION | Peak (PK) |
| FREQUENCY RANGE | 1GHz ~ 25GHz | | Average (AV) |

| ANTENNA POLARITY & TEST DISTANCE: HORIZONTAL AT 3 M | | | | | | | | |
|---|----------------|-------------------------------|-------------------|----------------|--------------------------|----------------------------|------------------------|--------------------------------|
| NO. | FREQ. (MHz) | EMISSION LEVEL (dBuV/m) | LIMIT (dBuV/m) | MARGIN (dB) | ANTENNA HEIGHT (m) | TABLE ANGLE (Degree) | RAW VALUE (dBuV) | CORRECTION FACTOR (dB/m) |
| 1 | *2437.00 | 106.65 PK | | | 1.70 H | 165 | 103.81 | 2.84 |
| 2 | *2437.00 | 98.10 AV | | | 1.70 H | 165 | 95.26 | 2.84 |
| 3 | 4874.00 | 54.20 PK | 74.00 | -19.80 | 1.95 H | 225 | 45.51 | 8.69 |
| 4 | 4874.00 | 40.32 AV | 54.00 | -13.68 | 1.95 H | 225 | 31.63 | 8.69 |
| 5 | 7311.00 | 51.29 PK | 74.00 | -22.71 | 1.65 H | 259 | 41.70 | 9.59 |
| 6 | 7311.00 | 40.39 AV | 54.00 | -13.61 | 1.65 H | 259 | 30.80 | 9.59 |
| ANTENNA POLARITY & TEST DISTANCE: VERTICAL AT 3 M | | | | | | | | |
| NO. | FREQ. (MHz) | EMISSION LEVEL (dBuV/m) | LIMIT (dBuV/m) | MARGIN (dB) | ANTENNA HEIGHT (m) | TABLE ANGLE (Degree) | RAW VALUE (dBuV) | CORRECTION FACTOR (dB/m) |
| 1 | *2437.00 | 99.35 PK | | | 1.00 V | 288 | 96.51 | 2.84 |
| 2 | *2437.00 | 89.15 AV | | | 1.00 V | 288 | 86.31 | 2.84 |
| 3 | 4874.00 | 51.29 PK | 74.00 | -22.71 | 1.00 V | 2 | 42.60 | 8.69 |
| 4 | 4874.00 | 37.00 AV | 54.00 | -17.00 | 1.00 V | 2 | 28.31 | 8.69 |
| 5 | 7311.00 | 51.29 PK | 74.00 | -22.71 | 1.92 V | 52 | 41.70 | 9.59 |
| 6 | 7311.00 | 41.65 AV | 54.00 | -12.35 | 1.92 V | 52 | 32.06 | 9.59 |

REMARKS:

1. Emission level (dBuV/m) = Raw Value (dBuV) + Correction Factor (dB/m).
2. Correction Factor (dB/m) = Antenna Factor (dB/m) + Cable Factor (dB).
3. The emission levels of other frequencies were less than 20dB margin against the limit.
4. Margin value = Emission level – Limit value.
5. " * " : Fundamental frequency.

| | | | |
|------------------------|---------------|------------------------------|--------------|
| CHANNEL | TX Channel 11 | DETECTOR FUNCTION | Peak (PK) |
| FREQUENCY RANGE | 1GHz ~ 25GHz | | Average (AV) |

| ANTENNA POLARITY & TEST DISTANCE: HORIZONTAL AT 3 M | | | | | | | | |
|---|----------------|-------------------------------|-------------------|----------------|--------------------------|----------------------------|------------------------|--------------------------------|
| NO. | FREQ. (MHz) | EMISSION LEVEL (dBuV/m) | LIMIT (dBuV/m) | MARGIN (dB) | ANTENNA HEIGHT (m) | TABLE ANGLE (Degree) | RAW VALUE (dBuV) | CORRECTION FACTOR (dB/m) |
| 1 | *2462.00 | 107.83 PK | | | 1.70 H | 338 | 104.91 | 2.92 |
| 2 | *2462.00 | 100.41 AV | | | 1.70 H | 338 | 97.49 | 2.92 |
| 3 | 2483.50 | 58.44 PK | 74.00 | -15.56 | 1.70 H | 338 | 55.46 | 2.98 |
| 4 | 2483.50 | 46.66 AV | 54.00 | -7.34 | 1.70 H | 338 | 43.68 | 2.98 |
| 5 | 4924.00 | 49.25 PK | 74.00 | -24.75 | 1.70 H | 22 | 40.20 | 9.05 |
| 6 | 4924.00 | 36.80 AV | 54.00 | -17.20 | 1.70 H | 22 | 27.75 | 9.05 |
| 7 | 7386.00 | 51.29 PK | 74.00 | -22.71 | 1.95 H | 201 | 41.66 | 9.63 |
| 8 | 7386.00 | 40.26 AV | 54.00 | -13.74 | 1.95 H | 201 | 30.63 | 9.63 |
| ANTENNA POLARITY & TEST DISTANCE: VERTICAL AT 3 M | | | | | | | | |
| NO. | FREQ. (MHz) | EMISSION LEVEL (dBuV/m) | LIMIT (dBuV/m) | MARGIN (dB) | ANTENNA HEIGHT (m) | TABLE ANGLE (Degree) | RAW VALUE (dBuV) | CORRECTION FACTOR (dB/m) |
| 1 | *2462.00 | 100.25 PK | | | 1.26 V | 234 | 97.33 | 2.92 |
| 2 | *2462.00 | 90.59 AV | | | 1.26 V | 234 | 87.67 | 2.92 |
| 3 | 2483.50 | 49.93 PK | 74.00 | -24.07 | 1.26 V | 234 | 46.95 | 2.98 |
| 4 | 2483.50 | 37.81 AV | 54.00 | -16.19 | 1.26 V | 234 | 34.83 | 2.98 |
| 5 | 4924.00 | 54.29 PK | 74.00 | -19.71 | 1.65 V | 96 | 45.24 | 9.05 |
| 6 | 4924.00 | 41.35 AV | 54.00 | -12.65 | 1.65 V | 96 | 32.30 | 9.05 |
| 7 | 7386.00 | 51.60 PK | 74.00 | -22.40 | 1.92 V | 201 | 41.97 | 9.63 |
| 8 | 7386.00 | 40.32 AV | 54.00 | -13.68 | 1.92 V | 201 | 30.69 | 9.63 |

REMARKS:

1. Emission level (dBuV/m) = Raw Value (dBuV) + Correction Factor (dB/m).
2. Correction Factor (dB/m) = Antenna Factor (dB/m) + Cable Factor (dB).
3. The emission levels of other frequencies were less than 20dB margin against the limit.
4. Margin value = Emission level – Limit value.
5. " * ": Fundamental frequency.

802.11n HT20

| | | | |
|------------------------|--------------|------------------------------|--------------|
| CHANNEL | TX Channel 1 | DETECTOR FUNCTION | Peak (PK) |
| FREQUENCY RANGE | 1GHz ~ 25GHz | | Average (AV) |

| ANTENNA POLARITY & TEST DISTANCE: HORIZONTAL AT 3 M | | | | | | | | |
|---|----------------|-------------------------------|-------------------|----------------|--------------------------|----------------------------|------------------------|--------------------------------|
| NO. | FREQ. (MHz) | EMISSION LEVEL (dBuV/m) | LIMIT (dBuV/m) | MARGIN (dB) | ANTENNA HEIGHT (m) | TABLE ANGLE (Degree) | RAW VALUE (dBuV) | CORRECTION FACTOR (dB/m) |
| 1 | 2390.00 | 51.28 PK | 74.00 | -22.72 | 1.50 H | 150 | 48.59 | 2.69 |
| 2 | 2390.00 | 41.51 AV | 54.00 | -12.49 | 1.50 H | 150 | 38.82 | 2.69 |
| 3 | *2412.00 | 103.70 PK | | | 1.50 H | 150 | 100.93 | 2.77 |
| 4 | *2412.00 | 95.62 AV | | | 1.50 H | 150 | 92.85 | 2.77 |
| 5 | 4824.00 | 51.00 PK | 74.00 | -23.00 | 1.62 H | 52 | 42.66 | 8.34 |
| 6 | 4824.00 | 40.26 AV | 54.00 | -13.74 | 1.62 H | 52 | 31.92 | 8.34 |
| 7 | #7236.00 | 51.65 PK | 74.00 | -22.35 | 2.30 H | 22 | 42.10 | 9.55 |
| 8 | #7236.00 | 41.66 AV | 54.00 | -12.34 | 2.30 H | 22 | 32.11 | 9.55 |
| ANTENNA POLARITY & TEST DISTANCE: VERTICAL AT 3 M | | | | | | | | |
| NO. | FREQ. (MHz) | EMISSION LEVEL (dBuV/m) | LIMIT (dBuV/m) | MARGIN (dB) | ANTENNA HEIGHT (m) | TABLE ANGLE (Degree) | RAW VALUE (dBuV) | CORRECTION FACTOR (dB/m) |
| 1 | 2390.00 | 49.00 PK | 74.00 | -25.00 | 1.51 V | 294 | 46.31 | 2.69 |
| 2 | 2390.00 | 38.63 AV | 54.00 | -15.37 | 1.51 V | 294 | 35.94 | 2.69 |
| 3 | *2412.00 | 100.73 PK | | | 1.40 V | 294 | 97.96 | 2.77 |
| 4 | *2412.00 | 90.66 AV | | | 1.40 V | 294 | 87.89 | 2.77 |
| 5 | 4824.00 | 49.25 PK | 74.00 | -24.75 | 1.00 V | 85 | 40.91 | 8.34 |
| 6 | 4824.00 | 38.10 AV | 54.00 | -15.90 | 1.00 V | 85 | 29.76 | 8.34 |
| 7 | #7236.00 | 51.29 PK | 74.00 | -22.71 | 1.00 V | 201 | 41.74 | 9.55 |
| 8 | #7236.00 | 40.28 AV | 54.00 | -13.72 | 1.00 V | 201 | 30.73 | 9.55 |

REMARKS:

1. Emission level (dBuV/m) = Raw Value (dBuV) + Correction Factor (dB/m).
2. Correction Factor (dB/m) = Antenna Factor (dB/m) + Cable Factor (dB).
3. The emission levels of other frequencies were less than 20dB margin against the limit.
4. Margin value = Emission level – Limit value.
5. " * ": Fundamental frequency.
6. " # ": The radiated frequency is out of the restricted band.

| | | | |
|------------------------|--------------|------------------------------|--------------|
| CHANNEL | TX Channel 6 | DETECTOR FUNCTION | Peak (PK) |
| FREQUENCY RANGE | 1GHz ~ 25GHz | | Average (AV) |

| ANTENNA POLARITY & TEST DISTANCE: HORIZONTAL AT 3 M | | | | | | | | |
|---|----------------|-------------------------------|-------------------|----------------|--------------------------|----------------------------|------------------------|--------------------------------|
| NO. | FREQ. (MHz) | EMISSION LEVEL (dBuV/m) | LIMIT (dBuV/m) | MARGIN (dB) | ANTENNA HEIGHT (m) | TABLE ANGLE (Degree) | RAW VALUE (dBuV) | CORRECTION FACTOR (dB/m) |
| 1 | *2437.00 | 105.20 PK | | | 1.50 H | 151 | 102.36 | 2.84 |
| 2 | *2437.00 | 96.20 AV | | | 1.50 H | 151 | 93.36 | 2.84 |
| 3 | 4874.00 | 51.29 PK | 74.00 | -22.71 | 1.95 H | 220 | 42.60 | 8.69 |
| 4 | 4874.00 | 40.32 AV | 54.00 | -13.68 | 1.95 H | 220 | 31.63 | 8.69 |
| 5 | 7311.00 | 52.39 PK | 74.00 | -21.61 | 1.97 H | 52 | 42.80 | 9.59 |
| 6 | 7311.00 | 41.00 AV | 54.00 | -13.00 | 1.97 H | 52 | 31.41 | 9.59 |
| ANTENNA POLARITY & TEST DISTANCE: VERTICAL AT 3 M | | | | | | | | |
| NO. | FREQ. (MHz) | EMISSION LEVEL (dBuV/m) | LIMIT (dBuV/m) | MARGIN (dB) | ANTENNA HEIGHT (m) | TABLE ANGLE (Degree) | RAW VALUE (dBuV) | CORRECTION FACTOR (dB/m) |
| 1 | *2437.00 | 101.25 PK | | | 1.00 V | 351 | 98.41 | 2.84 |
| 2 | *2437.00 | 90.35 AV | | | 1.00 V | 351 | 87.51 | 2.84 |
| 3 | 4874.00 | 49.68 PK | 74.00 | -24.32 | 1.00 V | 63 | 40.99 | 8.69 |
| 4 | 4874.00 | 37.00 AV | 54.00 | -17.00 | 1.00 V | 63 | 28.31 | 8.69 |
| 5 | 7311.00 | 51.20 PK | 74.00 | -22.80 | 1.00 V | 232 | 41.61 | 9.59 |
| 6 | 7311.00 | 40.36 AV | 54.00 | -13.64 | 1.00 V | 232 | 30.77 | 9.59 |

REMARKS:

1. Emission level (dBuV/m) = Raw Value (dBuV) + Correction Factor (dB/m).
2. Correction Factor (dB/m) = Antenna Factor (dB/m) + Cable Factor (dB).
3. The emission levels of other frequencies were less than 20dB margin against the limit.
4. Margin value = Emission level – Limit value.
5. " * ": Fundamental frequency.

| | | | |
|------------------------|---------------|------------------------------|--------------|
| CHANNEL | TX Channel 11 | DETECTOR FUNCTION | Peak (PK) |
| FREQUENCY RANGE | 1GHz ~ 25GHz | | Average (AV) |

| ANTENNA POLARITY & TEST DISTANCE: HORIZONTAL AT 3 M | | | | | | | | |
|---|----------------|-------------------------------|-------------------|----------------|--------------------------|----------------------------|------------------------|--------------------------------|
| NO. | FREQ. (MHz) | EMISSION LEVEL (dBuV/m) | LIMIT (dBuV/m) | MARGIN (dB) | ANTENNA HEIGHT (m) | TABLE ANGLE (Degree) | RAW VALUE (dBuV) | CORRECTION FACTOR (dB/m) |
| 1 | *2462.00 | 106.64 PK | | | 1.42 H | 337 | 103.72 | 2.92 |
| 2 | *2462.00 | 100.40 AV | | | 1.42 H | 337 | 97.48 | 2.92 |
| 3 | 2483.50 | 52.54 PK | 74.00 | -21.46 | 1.42 H | 337 | 49.56 | 2.98 |
| 4 | 2483.50 | 42.64 AV | 54.00 | -11.36 | 1.42 H | 337 | 39.66 | 2.98 |
| 5 | 4924.00 | 51.29 PK | 74.00 | -22.71 | 1.50 H | 62 | 42.24 | 9.05 |
| 6 | 4924.00 | 40.29 AV | 54.00 | -13.71 | 1.50 H | 62 | 31.24 | 9.05 |
| 7 | 7386.00 | 54.29 PK | 74.00 | -19.71 | 1.98 H | 74 | 44.66 | 9.63 |
| 8 | 7386.00 | 42.90 AV | 54.00 | -11.10 | 1.98 H | 74 | 33.27 | 9.63 |
| ANTENNA POLARITY & TEST DISTANCE: VERTICAL AT 3 M | | | | | | | | |
| NO. | FREQ. (MHz) | EMISSION LEVEL (dBuV/m) | LIMIT (dBuV/m) | MARGIN (dB) | ANTENNA HEIGHT (m) | TABLE ANGLE (Degree) | RAW VALUE (dBuV) | CORRECTION FACTOR (dB/m) |
| 1 | *2462.00 | 100.47 PK | | | 1.66 V | 288 | 97.55 | 2.92 |
| 2 | *2462.00 | 90.92 AV | | | 1.66 V | 288 | 88.00 | 2.92 |
| 3 | 2483.50 | 48.90 PK | 74.00 | -25.10 | 1.66 V | 288 | 45.92 | 2.98 |
| 4 | 2483.50 | 38.72 AV | 54.00 | -15.28 | 1.66 V | 288 | 35.74 | 2.98 |
| 5 | 4924.00 | 51.29 PK | 74.00 | -22.71 | 1.02 V | 52 | 42.24 | 9.05 |
| 6 | 4924.00 | 40.08 AV | 54.00 | -13.92 | 1.02 V | 52 | 31.03 | 9.05 |
| 7 | 7386.00 | 51.29 PK | 74.00 | -22.71 | 1.52 V | 92 | 41.66 | 9.63 |
| 8 | 7386.00 | 40.32 AV | 54.00 | -13.68 | 1.52 V | 92 | 30.69 | 9.63 |

REMARKS:

1. Emission level (dBuV/m) = Raw Value (dBuV) + Correction Factor (dB/m).
2. Correction Factor (dB/m) = Antenna Factor (dB/m) + Cable Factor (dB).
3. The emission levels of other frequencies were less than 20dB margin against the limit.
4. Margin value = Emission level – Limit value.
5. " * ": Fundamental frequency.

BELOW 1GHz WORST-CASE DATA:

BT-LE (GFSK)

| | | | |
|------------------------|---------------|------------------------------|-----------------|
| CHANNEL | TX Channel 39 | DETECTOR FUNCTION | Quasi-Peak (QP) |
| FREQUENCY RANGE | 9KHz ~ 1GHz | | |

| ANTENNA POLARITY & TEST DISTANCE: HORIZONTAL AT 3 M | | | | | | | | |
|---|----------------|-------------------------------|-------------------|----------------|---------------------------|----------------------------|------------------------|--------------------------------|
| NO. | FREQ. (MHz) | EMISSION LEVEL (dBuV/m) | LIMIT (dBuV/m) | MARGIN (dB) | ANTENNA HEIGHT (cm) | TABLE ANGLE (Degree) | RAW VALUE (dBuV) | CORRECTION FACTOR (dB/m) |
| 1 | 30.00 | 15.99 QP | 40.00 | -24.01 | 1.00 H | 145 | 34.10 | -18.11 |
| 2 | 120.16 | 21.51 QP | 43.50 | -21.99 | 1.00 H | 173 | 39.29 | -17.78 |
| 3 | 194.78 | 31.08 QP | 43.50 | -12.42 | 1.00 H | 180 | 48.72 | -17.64 |
| 4 | 311.36 | 23.47 QP | 46.00 | -22.53 | 1.00 H | 137 | 37.27 | -13.80 |
| 5 | 476.14 | 29.35 QP | 46.00 | -16.65 | 1.00 H | 240 | 38.80 | -9.45 |
| 6 | 665.79 | 30.44 QP | 46.00 | -15.56 | 1.00 H | 175 | 35.64 | -5.20 |

REMARKS:

1. Emission level (dBuV/m) = Raw Value (dBuV) + Correction Factor (dB/m).
2. Correction Factor (dB/m) = Antenna Factor (dB/m) + Cable Factor (dB).
3. The emission levels of other frequencies were less than 20dB margin against the limit.
4. Margin value = Emission level – Limit value.

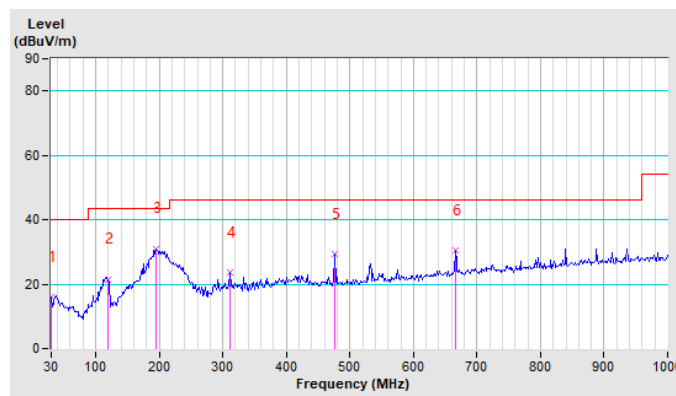

| | | | |
|------------------------|---------------|------------------------------|-----------------|
| CHANNEL | TX Channel 39 | DETECTOR FUNCTION | Quasi-Peak (QP) |
| FREQUENCY RANGE | 9KHz ~ 1GHz | | |

| ANTENNA POLARITY & TEST DISTANCE: VERTICAL AT 3 M | | | | | | | | |
|---|----------------|-------------------------------|-------------------|----------------|---------------------------|----------------------------|------------------------|--------------------------------|
| NO. | FREQ. (MHz) | EMISSION LEVEL (dBuV/m) | LIMIT (dBuV/m) | MARGIN (dB) | ANTENNA HEIGHT (cm) | TABLE ANGLE (Degree) | RAW VALUE (dBuV) | CORRECTION FACTOR (dB/m) |
| 1 | 39.33 | 15.34 QP | 40.00 | -24.66 | 1.94 V | 272 | 31.86 | -16.52 |
| 2 | 187.00 | 19.30 QP | 43.50 | -24.20 | 1.79 V | 287 | 36.51 | -17.21 |
| 3 | 218.09 | 18.61 QP | 46.00 | -27.39 | 1.65 V | 301 | 36.19 | -17.58 |
| 4 | 476.14 | 27.35 QP | 46.00 | -18.65 | 1.49 V | 317 | 36.80 | -9.45 |
| 5 | 533.65 | 33.15 QP | 46.00 | -12.85 | 1.34 V | 332 | 41.19 | -8.04 |
| 6 | 667.34 | 28.17 QP | 46.00 | -17.83 | 2.00 V | 255 | 33.35 | -5.18 |

REMARKS:

1. Emission level (dBuV/m) = Raw Value (dBuV) + Correction Factor (dB/m).
2. Correction Factor (dB/m) = Antenna Factor (dB/m) + Cable Factor (dB).
3. The emission levels of other frequencies were less than 20dB margin against the limit.
4. Margin value = Emission level – Limit value.

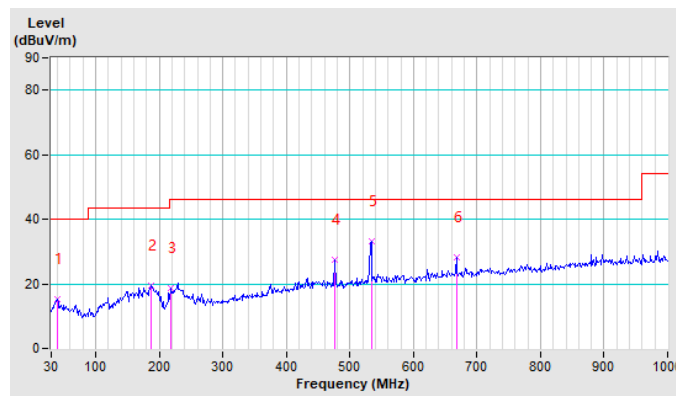

ABOVE 1GHz TEST DATA:

BT-LE (GFSK)

| | | | |
|------------------------|--------------|------------------------------|--------------|
| CHANNEL | TX Channel 0 | DETECTOR FUNCTION | Peak (PK) |
| FREQUENCY RANGE | 1GHz ~ 25GHz | | Average (AV) |

| ANTENNA POLARITY & TEST DISTANCE: HORIZONTAL AT 3 M | | | | | | | | |
|---|----------------|-------------------------------|-------------------|----------------|--------------------------|----------------------------|------------------------|--------------------------------|
| NO. | FREQ. (MHz) | EMISSION LEVEL (dBuV/m) | LIMIT (dBuV/m) | MARGIN (dB) | ANTENNA HEIGHT (m) | TABLE ANGLE (Degree) | RAW VALUE (dBuV) | CORRECTION FACTOR (dB/m) |
| 1 | 2390.00 | 51.98 PK | 74.00 | -22.02 | 1.66 H | 175 | 49.29 | 2.69 |
| 2 | 2390.00 | 40.18 AV | 54.00 | -13.82 | 1.66 H | 175 | 37.49 | 2.69 |
| 3 | *2402.00 | 116.57 PK | | | 1.66 H | 175 | 113.84 | 2.73 |
| 4 | *2402.00 | 116.40 AV | | | 1.66 H | 175 | 113.67 | 2.73 |
| 5 | 4804.00 | 51.29 PK | 74.00 | -22.71 | 1.64 H | 52 | 43.08 | 8.21 |
| 6 | 4804.00 | 41.25 AV | 54.00 | -12.75 | 1.64 H | 52 | 33.04 | 8.21 |
| 7 | #7206.00 | 55.20 PK | 74.00 | -18.80 | 1.60 H | 22 | 45.67 | 9.53 |
| 8 | #7206.00 | 41.20 AV | 54.00 | -12.80 | 1.60 H | 22 | 31.67 | 9.53 |
| ANTENNA POLARITY & TEST DISTANCE: VERTICAL AT 3 M | | | | | | | | |
| NO. | FREQ. (MHz) | EMISSION LEVEL (dBuV/m) | LIMIT (dBuV/m) | MARGIN (dB) | ANTENNA HEIGHT (m) | TABLE ANGLE (Degree) | RAW VALUE (dBuV) | CORRECTION FACTOR (dB/m) |
| 1 | 2390.00 | 47.55 PK | 74.00 | -26.45 | 1.00 V | 242 | 44.86 | 2.69 |
| 2 | 2390.00 | 35.99 AV | 54.00 | -18.01 | 1.00 V | 242 | 33.30 | 2.69 |
| 3 | *2402.00 | 112.36 PK | | | 1.00 V | 242 | 109.63 | 2.73 |
| 4 | *2402.00 | 112.00 AV | | | 1.00 V | 242 | 109.27 | 2.73 |
| 5 | 4804.00 | 48.75 PK | 74.00 | -25.25 | 1.64 V | 55 | 40.54 | 8.21 |
| 6 | 4804.00 | 37.51 AV | 54.00 | -16.49 | 1.64 V | 55 | 29.30 | 8.21 |
| 7 | #7206.00 | 51.29 PK | 74.00 | -22.71 | 1.00 V | 15 | 41.76 | 9.53 |
| 8 | #7206.00 | 39.00 AV | 54.00 | -15.00 | 1.00 V | 15 | 29.47 | 9.53 |

REMARKS:

1. Emission level (dBuV/m) = Raw Value (dBuV) + Correction Factor (dB/m).
2. Correction Factor (dB/m) = Antenna Factor (dB/m) + Cable Factor (dB).
3. The emission levels of other frequencies were less than 20dB margin against the limit.
4. Margin value = Emission level – Limit value.
5. " * ": Fundamental frequency.
6. " # ": The radiated frequency is out of the restricted band.

| | | | |
|------------------------|---------------|------------------------------|--------------|
| CHANNEL | TX Channel 19 | DETECTOR FUNCTION | Peak (PK) |
| FREQUENCY RANGE | 1GHz ~ 25GHz | | Average (AV) |

| ANTENNA POLARITY & TEST DISTANCE: HORIZONTAL AT 3 M | | | | | | | | |
|---|----------------|-------------------------------|-------------------|----------------|--------------------------|----------------------------|------------------------|--------------------------------|
| NO. | FREQ. (MHz) | EMISSION LEVEL (dBuV/m) | LIMIT (dBuV/m) | MARGIN (dB) | ANTENNA HEIGHT (m) | TABLE ANGLE (Degree) | RAW VALUE (dBuV) | CORRECTION FACTOR (dB/m) |
| 1 | *2440.00 | 116.25 PK | | | 1.70 H | 175 | 113.40 | 2.85 |
| 2 | *2440.00 | 116.00 AV | | | 1.70 H | 175 | 113.15 | 2.85 |
| 3 | 4880.00 | 51.29 PK | 74.00 | -22.71 | 1.65 H | 69 | 42.55 | 8.74 |
| 4 | 4880.00 | 41.32 AV | 54.00 | -12.68 | 1.65 H | 69 | 32.58 | 8.74 |
| 5 | 7320.00 | 52.36 PK | 74.00 | -21.64 | 1.09 H | 22 | 42.77 | 9.59 |
| 6 | 7320.00 | 40.95 AV | 54.00 | -13.05 | 1.09 H | 22 | 31.36 | 9.59 |
| ANTENNA POLARITY & TEST DISTANCE: VERTICAL AT 3 M | | | | | | | | |
| NO. | FREQ. (MHz) | EMISSION LEVEL (dBuV/m) | LIMIT (dBuV/m) | MARGIN (dB) | ANTENNA HEIGHT (m) | TABLE ANGLE (Degree) | RAW VALUE (dBuV) | CORRECTION FACTOR (dB/m) |
| 1 | *2440.00 | 114.68 PK | | | 1.00 V | 50 | 111.83 | 2.85 |
| 2 | *2440.00 | 114.36 AV | | | 1.00 V | 50 | 111.51 | 2.85 |
| 3 | 4880.00 | 52.36 PK | 74.00 | -21.64 | 1.69 V | 304 | 43.62 | 8.74 |
| 4 | 4880.00 | 40.20 AV | 54.00 | -13.80 | 1.69 V | 304 | 31.46 | 8.74 |
| 5 | 7320.00 | 50.39 PK | 74.00 | -23.61 | 1.80 V | 62 | 40.80 | 9.59 |
| 6 | 7320.00 | 40.28 AV | 54.00 | -13.72 | 1.80 V | 62 | 30.69 | 9.59 |

REMARKS:

1. Emission level (dBuV/m) = Raw Value (dBuV) + Correction Factor (dB/m).
2. Correction Factor (dB/m) = Antenna Factor (dB/m) + Cable Factor (dB).
3. The emission levels of other frequencies were less than 20dB margin against the limit.
4. Margin value = Emission level – Limit value.
5. " * " : Fundamental frequency.

| | | | |
|------------------------|---------------|------------------------------|--------------|
| CHANNEL | TX Channel 39 | DETECTOR FUNCTION | Peak (PK) |
| FREQUENCY RANGE | 1GHz ~ 25GHz | | Average (AV) |

| ANTENNA POLARITY & TEST DISTANCE: HORIZONTAL AT 3 M | | | | | | | | |
|---|----------------|-------------------------------|-------------------|----------------|--------------------------|----------------------------|------------------------|--------------------------------|
| NO. | FREQ. (MHz) | EMISSION LEVEL (dBuV/m) | LIMIT (dBuV/m) | MARGIN (dB) | ANTENNA HEIGHT (m) | TABLE ANGLE (Degree) | RAW VALUE (dBuV) | CORRECTION FACTOR (dB/m) |
| 1 | *2480.00 | 113.09 PK | | | 1.47 H | 114 | 110.12 | 2.97 |
| 2 | *2480.00 | 112.96 AV | | | 1.47 H | 114 | 109.99 | 2.97 |
| 3 | 2483.50 | 73.72 PK | 74.00 | -0.28 | 1.47 H | 114 | 70.74 | 2.98 |
| 4 | 2483.50 | 61.74 AV | 54.00 | 7.74 | 1.47 H | 114 | 58.76 | 2.98 |
| 5 | 4960.00 | 51.29 PK | 74.00 | -22.71 | 1.09 H | 229 | 41.99 | 9.30 |
| 6 | 4960.00 | 43.20 AV | 54.00 | -10.80 | 1.09 H | 229 | 33.90 | 9.30 |
| 7 | 7440.00 | 51.36 PK | 74.00 | -22.64 | 1.00 H | 84 | 41.70 | 9.66 |
| 8 | 7440.00 | 44.29 AV | 54.00 | -9.71 | 1.00 H | 84 | 34.63 | 9.66 |
| ANTENNA POLARITY & TEST DISTANCE: VERTICAL AT 3 M | | | | | | | | |
| NO. | FREQ. (MHz) | EMISSION LEVEL (dBuV/m) | LIMIT (dBuV/m) | MARGIN (dB) | ANTENNA HEIGHT (m) | TABLE ANGLE (Degree) | RAW VALUE (dBuV) | CORRECTION FACTOR (dB/m) |
| 1 | *2480.00 | 110.00 PK | | | 1.66 V | 64 | 107.03 | 2.97 |
| 2 | *2480.00 | 109.91 AV | | | 1.66 V | 64 | 106.94 | 2.97 |
| 3 | 2483.50 | 68.70 PK | 74.00 | -5.30 | 1.66 V | 54 | 65.72 | 2.98 |
| 4 | 2483.50 | 59.03 AV | 54.00 | 5.03 | 1.66 V | 54 | 56.05 | 2.98 |
| 5 | 4960.00 | 51.29 PK | 74.00 | -22.71 | 1.09 V | 51 | 41.99 | 9.30 |
| 6 | 4960.00 | 40.28 AV | 54.00 | -13.72 | 1.09 V | 51 | 30.98 | 9.30 |
| 7 | 7440.00 | 51.29 PK | 74.00 | -22.71 | 3.00 V | 51 | 41.63 | 9.66 |
| 8 | 7440.00 | 40.32 AV | 54.00 | -13.68 | 3.00 V | 51 | 30.66 | 9.66 |

REMARKS:

1. Emission level (dBuV/m) = Raw Value (dBuV) + Correction Factor (dB/m).
2. Correction Factor (dB/m) = Antenna Factor (dB/m) + Cable Factor (dB).
3. The emission levels of other frequencies were less than 20dB margin against the limit.
4. Margin value = Emission level – Limit value.
5. " * ": Fundamental frequency.

4.3 6dB BANDWIDTH MEASUREMENT

4.3.1 LIMITS OF 6dB BANDWIDTH MEASUREMENT

The minimum of 6dB Bandwidth Measurement is 0.5 MHz.

4.3.2 TEST INSTRUMENTS

| Equipment | Manufacturer | Model No. | Serial No. | Next Cal. |
|----------------------------------|---------------|-------------------------------|-------------|-------------|
| Power Sensor | Keysight | U2021XA | MY57320002 | Jan. 11, 24 |
| Power Meter | Anritsu | ML2495A | 1139001 | Aug. 22, 23 |
| Power Sensor | Anritsu | MA2411B | 1531155 | Aug. 22, 23 |
| Digital Multimeter | FLUKE | 15B | A1220010DG | N/A |
| Humid & Temp Programmable Tester | Haida | HD-225T | 110807201 | Nov. 02, 23 |
| Oscilloscope | Agilent | DSO9254A | MY51260160 | Jul. 27, 23 |
| Signal and Spectrum Analyzer | Rohde&Schwarz | FSV40 | 101094 | Jan. 11, 24 |
| Signal Generator | Agilent | N5183A | MY50140980 | Jul. 20, 23 |
| MXG-B RF Vector Signal Generator | Keysight | N5182B | MY56200288 | Jul. 20, 23 |
| BLUETOOTH TESTER | Rohde&Schwarz | CBT32 | 100811 | N/A |
| Attenuator | MINI | BW-S10W2+ | S130129FGE2 | N/A |
| DC Source | Keysight | E3642A | MY56146098 | N/A |
| Test software | ADT | ADT_RF Test Software V6.6.5.3 | N/A | N/A |

NOTE:

1. The test was performed in RF Oven room.
2. The calibration interval of the above test instruments is 12 months and the calibrations are traceable to CEPREI/CHINA, GRGT/CHINA and NIM/CHINA.

4.3.3 TEST PROCEDURE

1. Set resolution bandwidth (RBW) = 100KHz
2. Set the video bandwidth (VBW) $\geq 3 \times$ RBW, Detector = Peak.
3. Trace mode = max hold.
4. Sweep = auto couple.
5. Measure the maximum width of the emission that is constrained by the frequencies associated with the two amplitude points (upper and lower) that are attenuated by 6 dB relative to the maximum level measured in the fundamental emission.



4.3.4 DEVIATION FROM TEST STANDARD

No deviation.

4.3.5 TEST SETUP

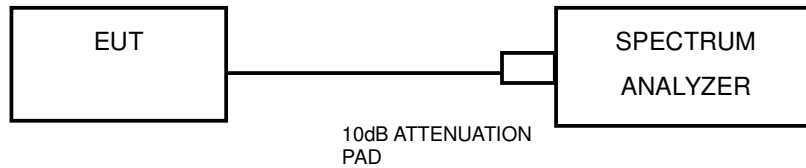

4.3.6 EUT OPERATING CONDITIONS

The software provided by client to enable the EUT under transmission condition continuously at lowest, middle and highest channel frequencies individually.



4.3.7 TEST RESULTS

802.11b

| CHANNEL | CHANNEL FREQUENCY (MHz) | 6dB BANDWIDTH (MHz) | MINIMUM LIMIT (MHz) | PASS / FAIL |
|---------|-------------------------|---------------------|---------------------|-------------|
| 1 | 2412 | 8.41 | 0.5 | PASS |
| 6 | 2437 | 8.56 | 0.5 | PASS |
| 11 | 2462 | 8.92 | 0.5 | PASS |

802.11g

| CHANNEL | CHANNEL FREQUENCY (MHz) | 6dB BANDWIDTH (MHz) | MINIMUM LIMIT (MHz) | PASS / FAIL |
|---------|-------------------------|---------------------|---------------------|-------------|
| 1 | 2412 | 16.49 | 0.5 | PASS |
| 6 | 2437 | 16.50 | 0.5 | PASS |
| 11 | 2462 | 16.42 | 0.5 | PASS |

802.11n HT20

| CHANNEL | CHANNEL FREQUENCY (MHz) | 6dB BANDWIDTH (MHz) | MINIMUM LIMIT (MHz) | PASS / FAIL |
|---------|-------------------------|---------------------|---------------------|-------------|
| 1 | 2412 | 17.69 | 0.5 | PASS |
| 6 | 2437 | 17.56 | 0.5 | PASS |
| 11 | 2462 | 17.40 | 0.5 | PASS |

BT-LE (GFSK)

| CHANNEL | CHANNEL FREQUENCY (MHz) | 6dB BANDWIDTH (MHz) | MINIMUM LIMIT (MHz) | PASS / FAIL |
|---------|-------------------------|---------------------|---------------------|-------------|
| 0 | 2402 | 0.657 | 0.5 | PASS |
| 19 | 2440 | 0.659 | 0.5 | PASS |
| 39 | 2480 | 0.658 | 0.5 | PASS |

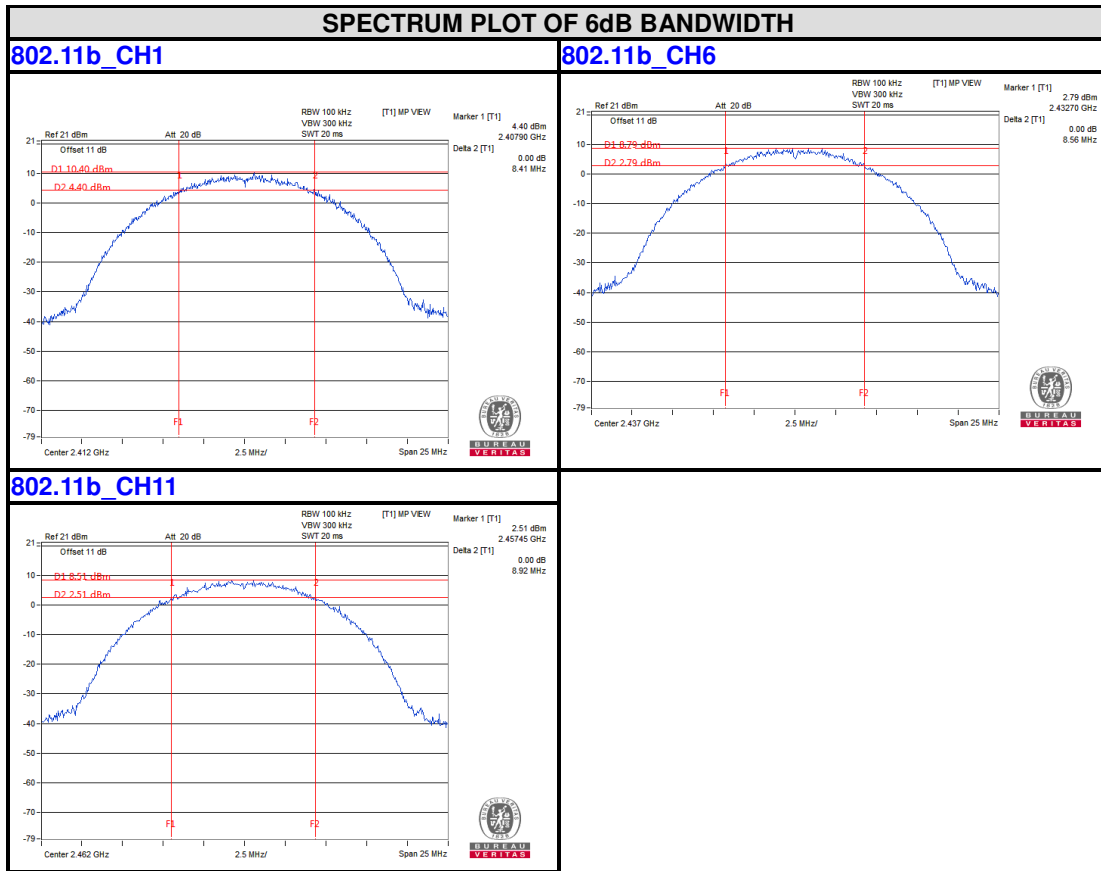

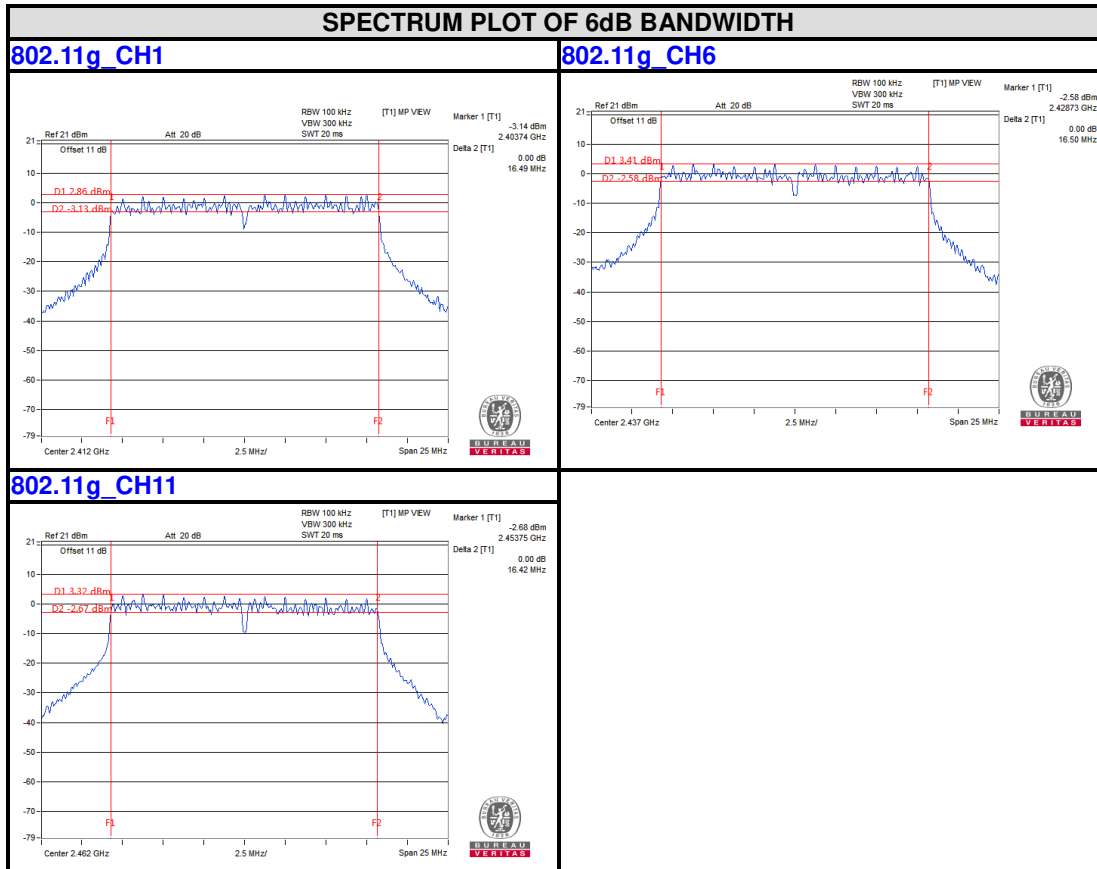

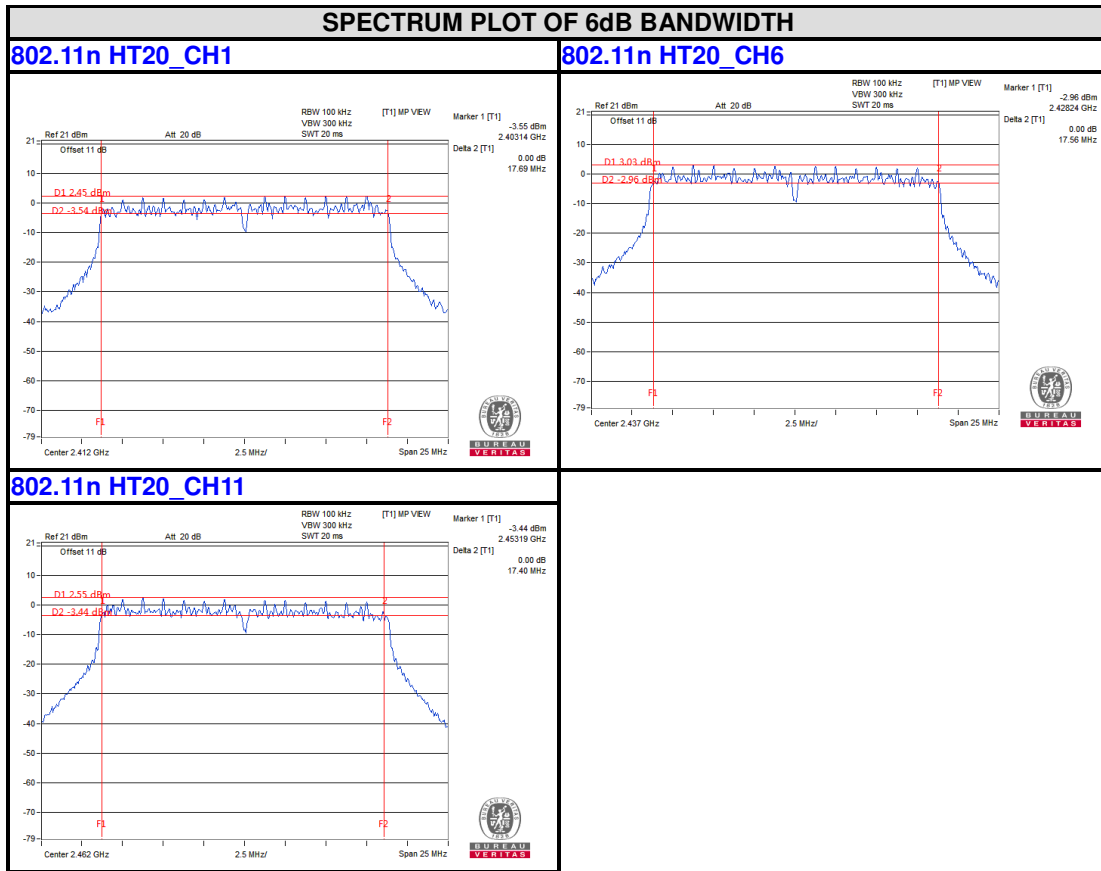



BUREAU VERITAS

Test Report No.: RF2304WDG0057

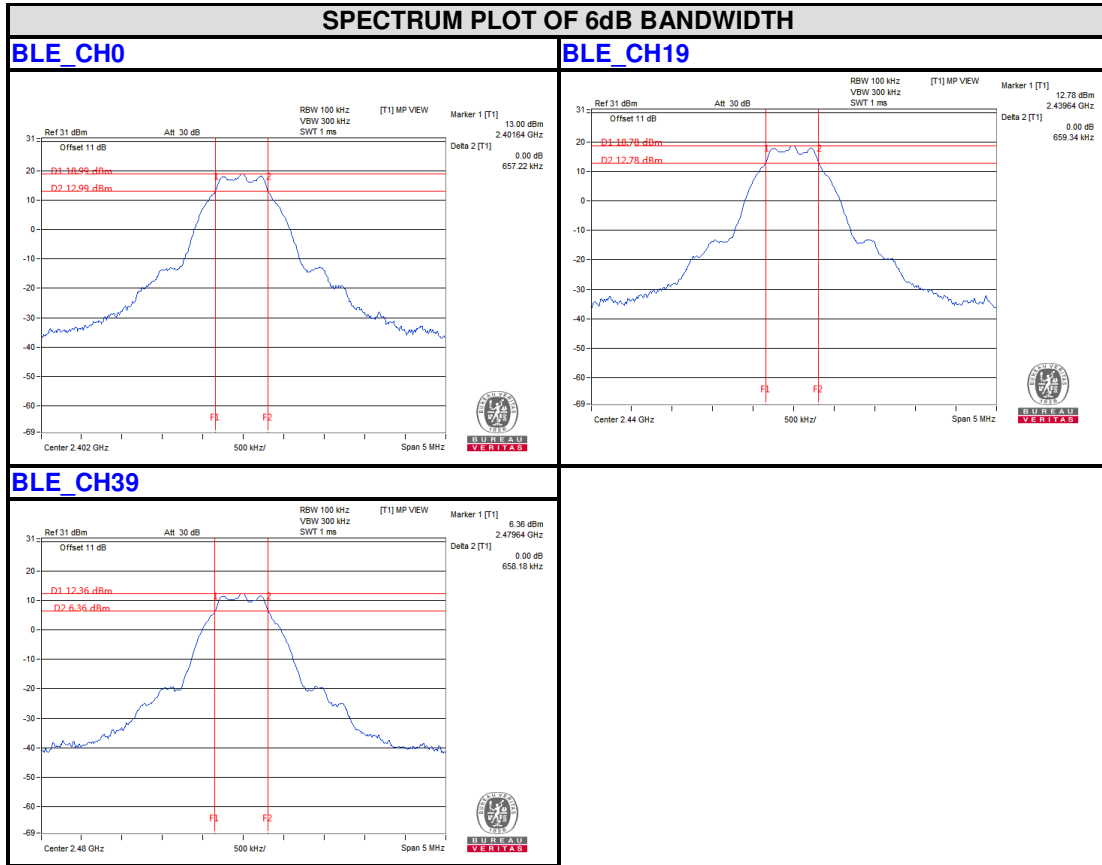

Bureau Veritas Shenzhen Co., Ltd.
Dongguan Branch

No. 96, Guantai Road (Houjie Section), Houjie
Town, Dongguan City, Guangdong Province.
523942, People's Republic of China.

Tel: +86 769 8998 2098
Fax: +86 769 8593 1080
Email: customerservice.dg@bureauveritas.com

4.4 CONDUCTED OUTPUT POWER

4.4.1 LIMITS OF CONDUCTED OUTPUT POWER MEASUREMENT

For systems using digital modulation in the 2400–2483.5 MHz band: 1 Watt (30dBm).

4.4.2 TEST SETUP

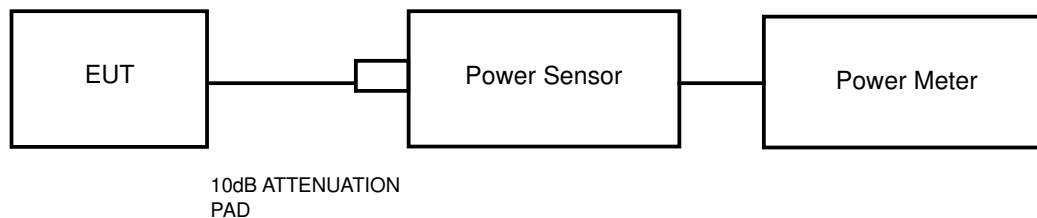

4.4.3 TEST INSTRUMENTS

| Equipment | Manufacturer | Model No. | Serial No. | Next Cal. |
|----------------------------------|---------------|-------------------------------|-------------|-------------|
| Power Sensor | Keysight | U2021XA | MY57320002 | Jan. 11, 24 |
| Power Meter | Anritsu | ML2495A | 1139001 | Aug. 22, 23 |
| Power Sensor | Anritsu | MA2411B | 1531155 | Aug. 22, 23 |
| Digital Multimeter | FLUKE | 15B | A1220010DG | N/A |
| Humid & Temp Programmable Tester | Haida | HD-225T | 110807201 | Nov. 02, 23 |
| Oscilloscope | Agilent | DSO9254A | MY51260160 | Jul. 27, 23 |
| Signal and Spectrum Analyzer | Rohde&Schwarz | FSV40 | 101094 | Jan. 11, 24 |
| Signal Generator | Agilent | N5183A | MY50140980 | Jul. 20, 23 |
| MXG-B RF Vector Signal Generator | Keysight | N5182B | MY56200288 | Jul. 20, 23 |
| BLUETOOTH TESTER | Rohde&Schwarz | CBT32 | 100811 | N/A |
| Attenuator | MINI | BW-S10W2+ | S130129FGE2 | N/A |
| DC Source | Keysight | E3642A | MY56146098 | N/A |
| Test software | ADT | ADT_RF Test Software V6.6.5.3 | N/A | N/A |

NOTE:

1. The test was performed in RF Oven room.
2. The calibration interval of the above test instruments is 12 months and the calibrations are traceable to CEPREI/CHINA, GRGT/CHINA and NIM/CHINA.



4.4.4 TEST PROCEDURES

A peak power sensor was used on the output port of the EUT. A power meter was used to read the response of the peak power sensor and set the detector to PEAK. Record the power level.

An average power sensor was used on the output port of the EUT. A power meter was used to read the response of the average power sensor and set the detector to AVERAGE. Record the power level.

4.4.5 DEVIATION FROM TEST STANDARD

No deviation.

4.4.6 EUT OPERATING CONDITIONS

The software provided by client to enable the EUT under transmission condition continuously at lowest, middle and highest channel frequencies individually.

4.4.7 TEST RESULTS

MAXIMUM PEAK OUTPUT POWER

802.11b

| CHANNEL | CHANNEL FREQUENCY (MHz) | PEAK POWER (dBm) | PEAK POWER (mW) | PEAK POWER LIMIT (W) | PASS/FAIL |
|---------|-------------------------|------------------|-----------------|----------------------|-----------|
| 1 | 2412 | 23.42 | 219.786 | 1 | PASS |
| 6 | 2437 | 23.62 | 230.144 | 1 | PASS |
| 11 | 2462 | 23.64 | 231.206 | 1 | PASS |

802.11g

| CHANNEL | CHANNEL FREQUENCY (MHz) | PEAK POWER (dBm) | PEAK POWER (mW) | PEAK POWER LIMIT (W) | PASS/FAIL |
|---------|-------------------------|------------------|-----------------|----------------------|-----------|
| 1 | 2412 | 22.65 | 184.077 | 1 | PASS |
| 6 | 2437 | 22.68 | 185.353 | 1 | PASS |
| 11 | 2462 | 22.21 | 166.341 | 1 | PASS |

802.11n HT20

| CHANNEL | CHANNEL FREQUENCY (MHz) | PEAK POWER (dBm) | PEAK POWER (mW) | PEAK POWER LIMIT (W) | PASS/FAIL |
|---------|-------------------------|------------------|-----------------|----------------------|-----------|
| 1 | 2412 | 21.96 | 157.036 | 1 | PASS |
| 6 | 2437 | 22.06 | 160.694 | 1 | PASS |
| 11 | 2462 | 21.32 | 135.519 | 1 | PASS |



BT-LE (GFSK)

| CHANNEL | CHANNEL FREQUENCY (MHz) | PEAK POWER (dBm) | PEAK POWER (mW) | PEAK POWER LIMIT (W) | PASS/FAIL |
|---------|-------------------------|------------------|-----------------|----------------------|-----------|
| 0 | 2402 | 19.02 | 79.799 | 1 | PASS |
| 19 | 2440 | 18.93 | 78.163 | 1 | PASS |
| 39 | 2480 | 12.40 | 17.378 | 1 | PASS |

AVERAGE OUTPUT POWER (FOR REFERENCE)

The average power sensor was used on the output port of the EUT. A power meter was used to read the response of the power sensor. Record the power level.

802.11b

| CHANNEL | CHANNEL FREQUENCY(MHz) | AVERAGE POWER (dBm) | AVG. POWER (mW) |
|---------|------------------------|---------------------|-----------------|
| 1 | 2412 | 17.03 | 50.466 |
| 6 | 2437 | 17.21 | 52.602 |
| 11 | 2462 | 17.30 | 53.703 |

Note: This power value includes Duty factor.

802.11g

| CHANNEL | CHANNEL FREQUENCY(MHz) | AVERAGE POWER (dBm) | AVG. POWER (mW) |
|---------|------------------------|---------------------|-----------------|
| 1 | 2412 | 14.68 | 29.376 |
| 6 | 2437 | 14.71 | 29.58 |
| 11 | 2462 | 14.54 | 28.445 |

Note: This power value includes Duty factor.

802.11n HT20

| CHANNEL | CHANNEL FREQUENCY(MHz) | AVERAGE POWER (dBm) | AVG. POWER (mW) |
|---------|------------------------|---------------------|-----------------|
| 1 | 2412 | 13.70 | 23.442 |
| 6 | 2437 | 14.17 | 26.122 |
| 11 | 2462 | 13.65 | 23.174 |

Note: This power value includes Duty factor.



Test Report No.: RF2304WDG0057

BT-LE (GFSK)

| CHANNEL | CHANNEL FREQUENCY(MHz) | AVERAGE POWER (dBm) | AVG. POWER (mW) |
|---------|------------------------|---------------------|-----------------|
| 0 | 2402 | 17.13 | 51.642 |
| 19 | 2440 | 16.93 | 49.317 |
| 39 | 2480 | 10.58 | 11.429 |

Note: This power value includes Duty factor.

4.5 POWER SPECTRAL DENSITY MEASUREMENT

4.5.1 LIMITS OF POWER SPECTRAL DENSITY MEASUREMENT

The Maximum of Power Spectral Density Measurement is 8dBm/3KHz.

4.5.2 TEST SETUP

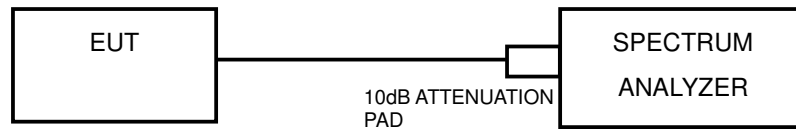

4.5.3 TEST INSTRUMENTS

Refer to section 4.3.2 to get information of above instrument.

4.5.4 TEST PROCEDURE

- a) Set instrument center frequency to DTS channel center frequency.
- b) Set the span to 1.5 times the DTS bandwidth.
- c) Set RBW to: 3KHz
- d) Set VBW $\geq 3 \times$ RBW.
- e) Detector = peak
- f) Ensure that the number of measurement points in the sweep $\geq 2 \times$ span/RBW.
- g) Sweep time = auto couple.
- h) Use the peak marker function to determine the maximum amplitude level.

4.5.5 DEVIATION FROM TEST STANDARD

No deviation.

4.5.6 EUT OPERATING CONDITION

Same as item 4.3.6.

4.5.7 TEST RESULTS

802.11b

| Channel | FREQ. (MHz) | PSD (dBm/3kHz) | Limit (dBm/3kHz) | PASS /FAIL |
|---------|----------------|-------------------|---------------------|---------------|
| 1 | 2412 | -5.07 | 8.00 | PASS |
| 6 | 2437 | -5.71 | 8.00 | PASS |
| 11 | 2462 | -6.38 | 8.00 | PASS |

Note: This PSD value includes Duty factor.

802.11g

| Channel | FREQ. (MHz) | PSD (dBm/3kHz) | Limit (dBm/3kHz) | PASS /FAIL |
|---------|----------------|-------------------|---------------------|---------------|
| 1 | 2412 | -13.04 | 8.00 | PASS |
| 6 | 2437 | -9.69 | 8.00 | PASS |
| 11 | 2462 | -11.52 | 8.00 | PASS |

Note: This PSD value includes Duty factor.

802.11n HT20

| Channel | FREQ. (MHz) | PSD (dBm/3kHz) | Limit (dBm/3kHz) | PASS /FAIL |
|---------|----------------|-------------------|---------------------|---------------|
| 1 | 2412 | -11.78 | 8.00 | PASS |
| 6 | 2437 | -11.86 | 8.00 | PASS |
| 11 | 2462 | -13.77 | 8.00 | PASS |

Note: This PSD value includes Duty factor.



Test Report No.: RF2304WDG0057

BT-LE (GFSK)

| Channel | FREQ. (MHz) | PSD (dBm/3kHz) | Limit (dBm/3kHz) | PASS /FAIL |
|---------|----------------|-------------------|---------------------|---------------|
| 0 | 2402 | 4.10 | 8.00 | PASS |
| 19 | 2440 | 3.96 | 8.00 | PASS |
| 39 | 2480 | -2.58 | 8.00 | PASS |

Note: This PSD value includes Duty factor.



BUREAU VERITAS

Test Report No.: RF2304WDG0057

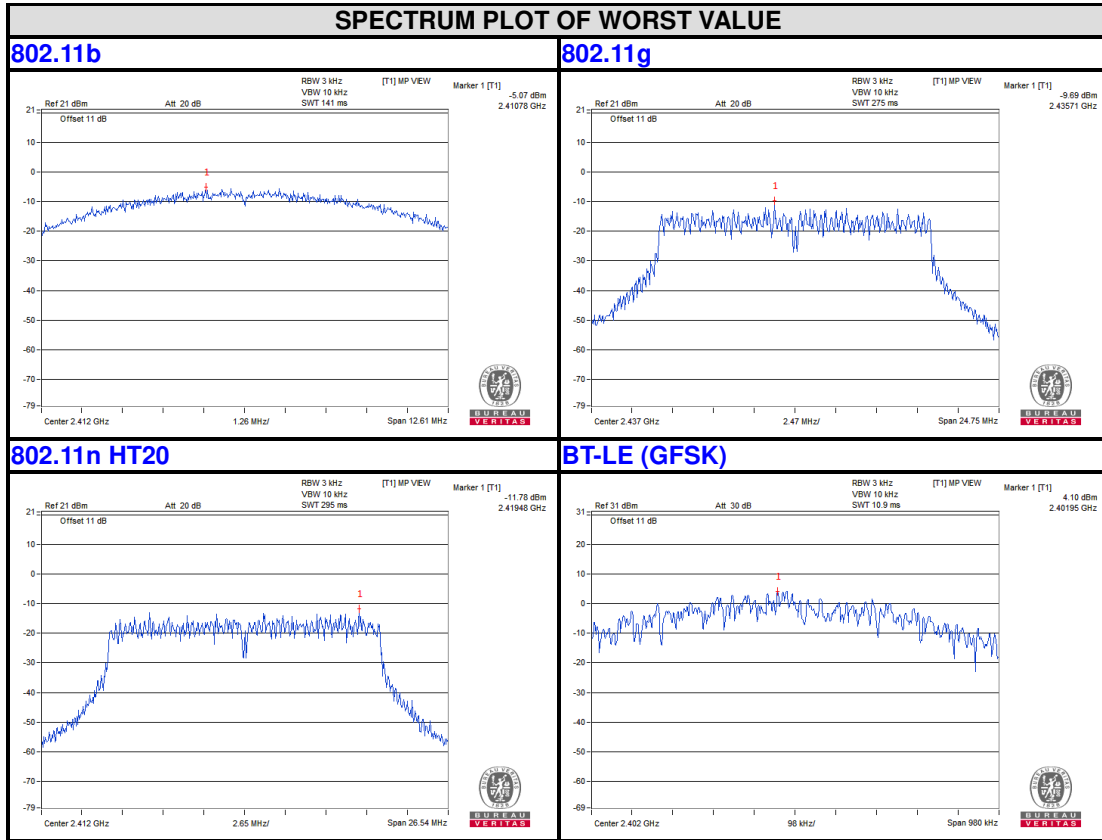

Bureau Veritas Shenzhen Co., Ltd.
Dongguan Branch

No. 96, Guantai Road (Houjie Section), Houjie
Town, Dongguan City, Guangdong Province.
523942, People's Republic of China.

Tel: +86 769 8998 2098
Fax: +86 769 8593 1080
Email: customerservice.dg@bureauveritas.com

4.6 OUT OF BAND EMISSION MEASUREMENT

4.6.1 LIMITS OF OUT OF BAND EMISSION MEASUREMENT

Below -20dB of the highest emission level of operating band (in 100kHz Resolution Bandwidth).

4.6.2 TEST SETUP

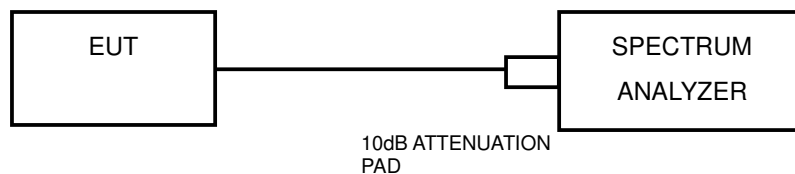

4.6.3 TEST INSTRUMENTS

Refer to section 4.3.2 to get information of above instrument.

4.6.4 TEST PROCEDURE

Measurement Procedure - Reference Level

1. Set the RBW = 100 kHz.
2. Set the VBW \geq 300 kHz.
3. Detector = peak.
4. Sweep time = auto couple.
5. Trace mode = max hold.
6. Allow trace to fully stabilize.
7. Use the peak marker function to determine the maximum power level in any 100 kHz band segment within the fundamental EBW.



Measurement Procedure –Unwanted Emission Level

1. Set RBW = 100 kHz.
2. Set VBW \geq 300 kHz.
3. Set span to encompass the spectrum to be examined
4. Detector = peak.
5. Trace Mode = max hold.
6. Sweep = auto couple.

4.6.5 DEVIATION FROM TEST STANDARD

No deviation.

4.6.6 EUT OPERATING CONDITION

Same as item 4.3.6

4.6.7 TEST RESULTS

802.11b

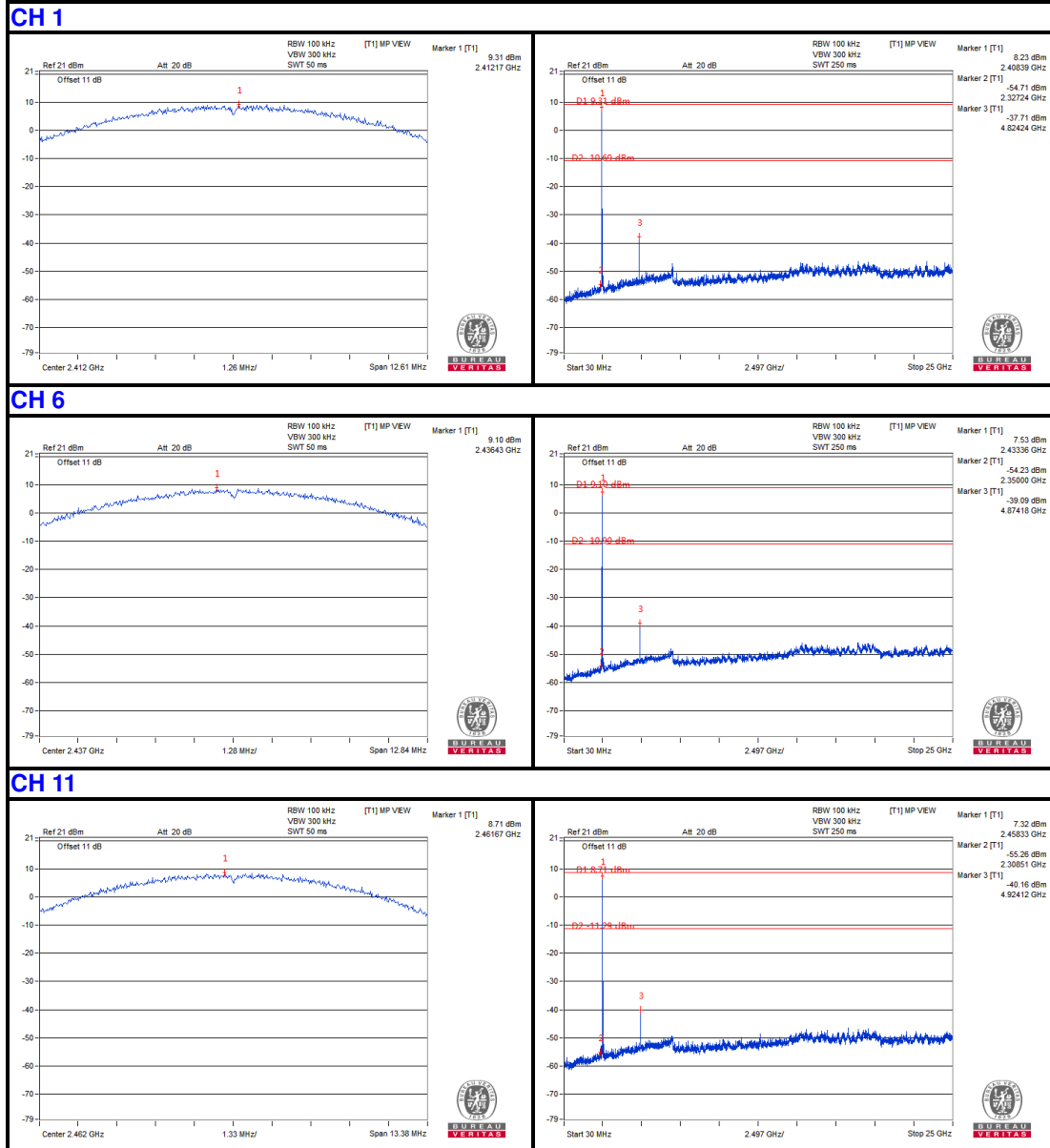

802.11g

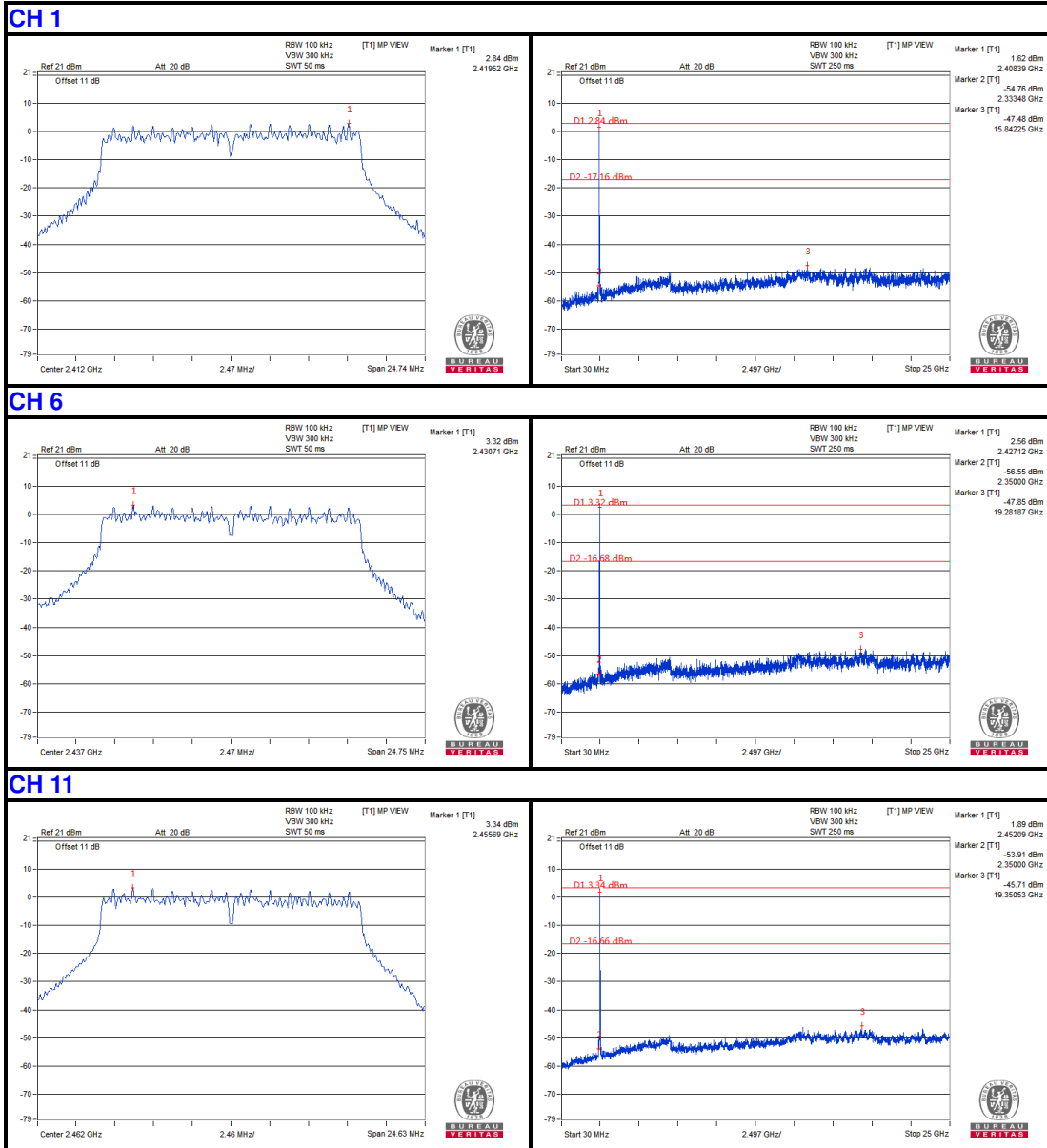

802.11n (HT20)

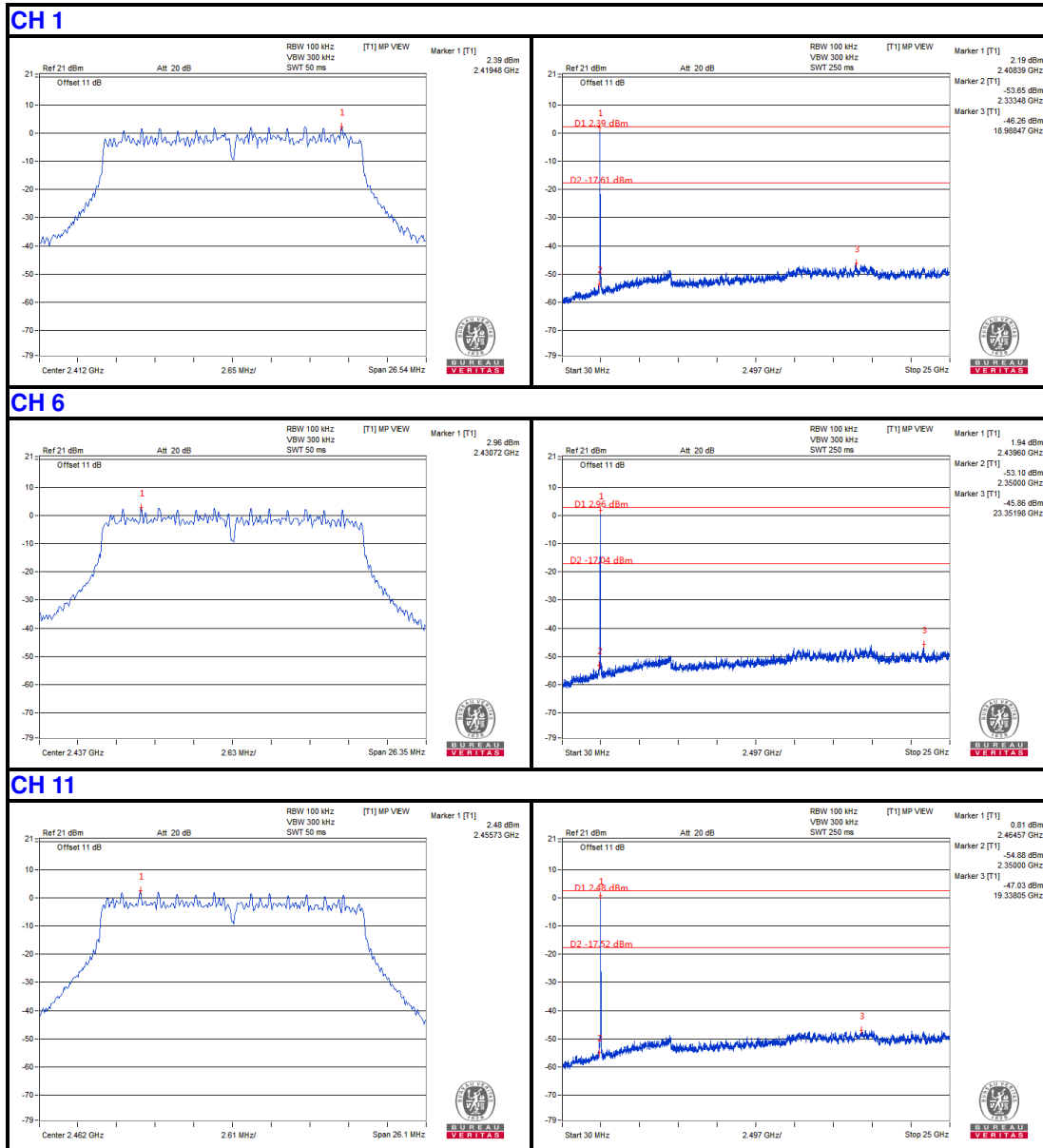

BT-LE (GFSK)

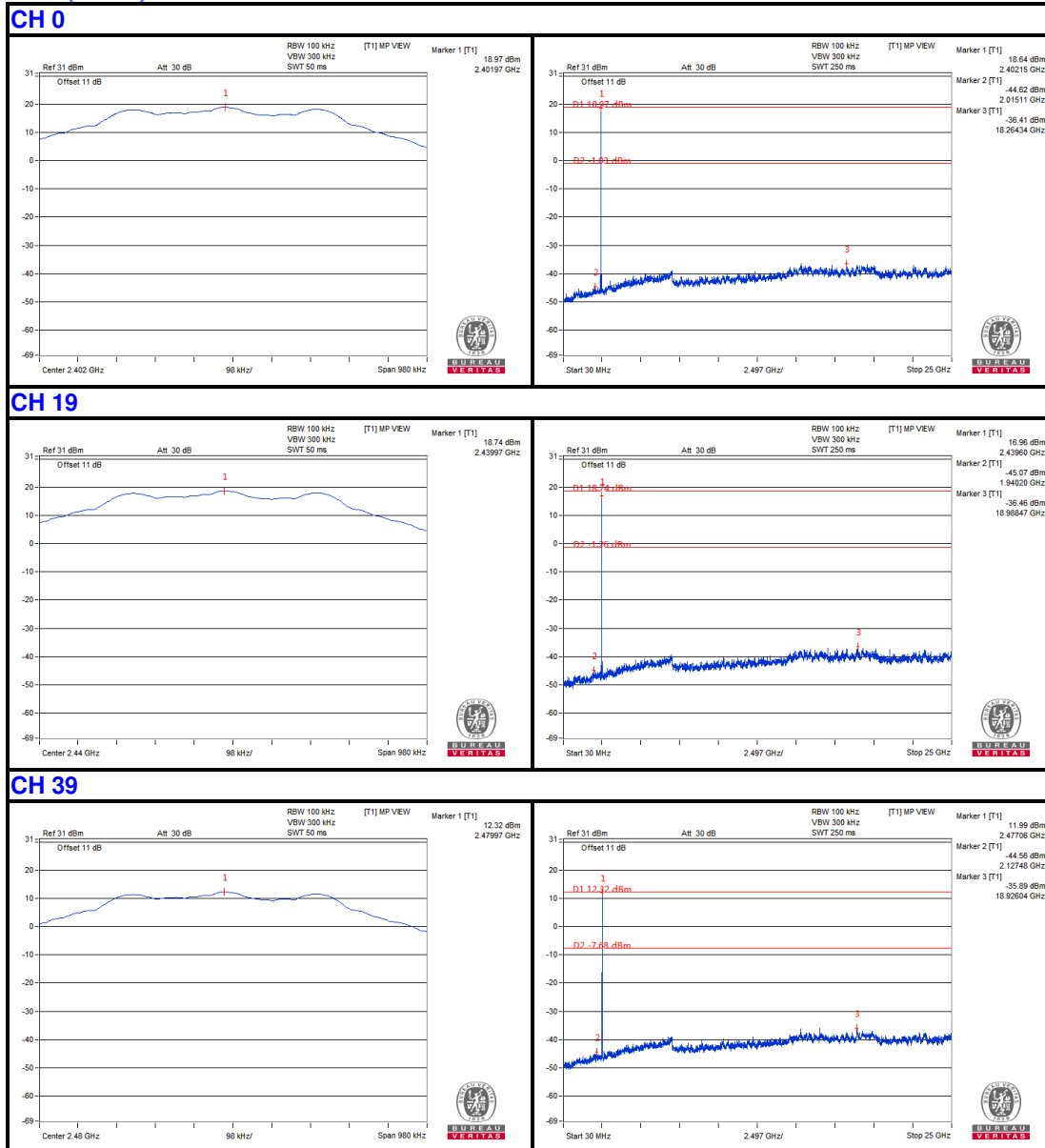

802.11b

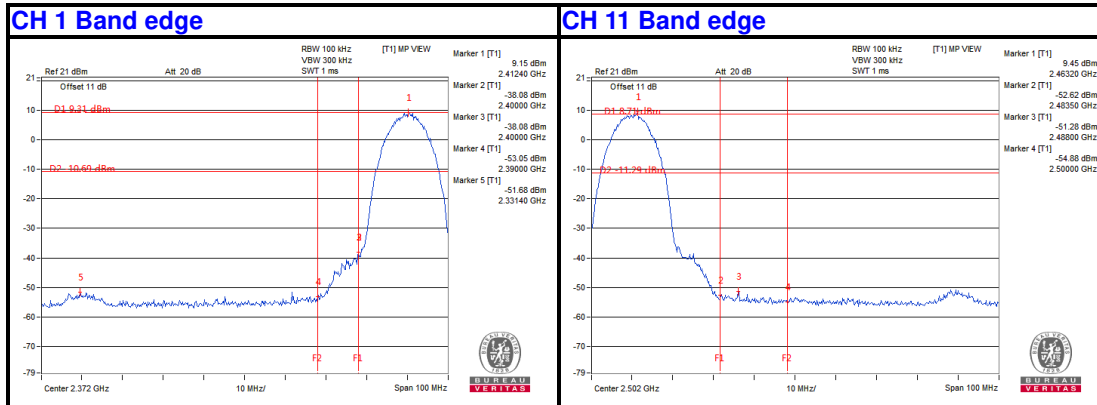

802.11g

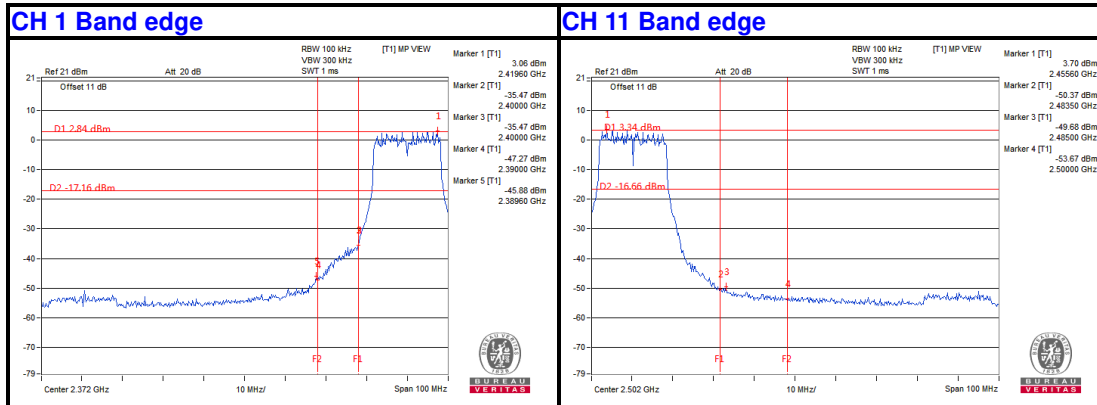

802.11n HT20

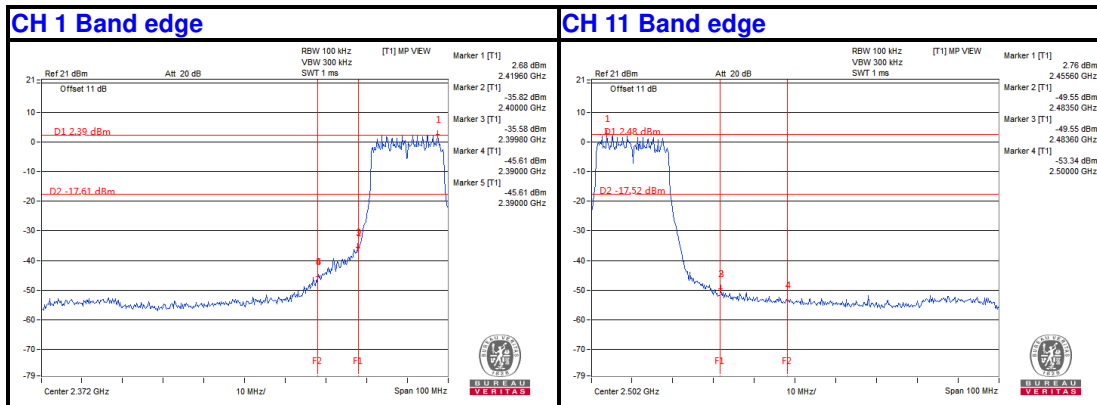

BT-LE (GFSK)

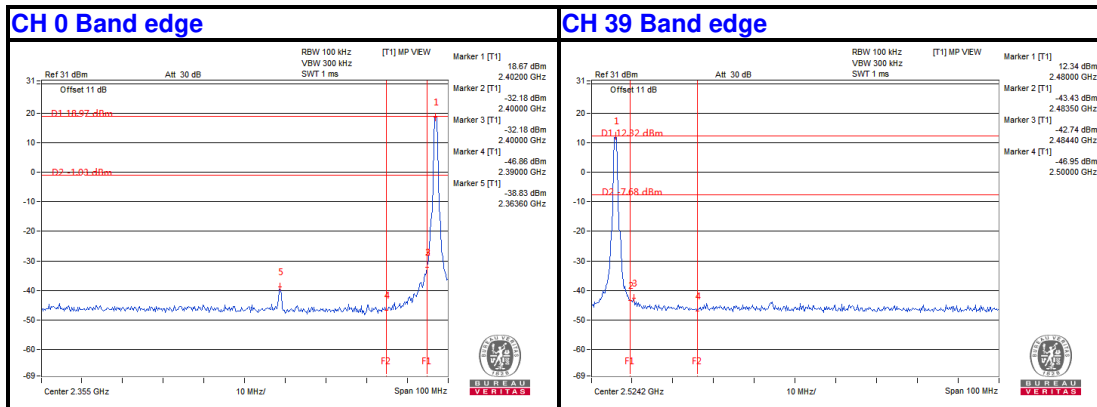



Test Report No.: RF2304WDG0057

5 PHOTOGRAPHS OF THE TEST CONFIGURATION

Please refer to the attached file (Test Setup Photo).



Test Report No.: RF2304WDG0057

6 APPENDIX A - MODIFICATIONS RECORDERS FOR ENGINEERING CHANGES TO THE EUT BY THE LAB

No any modifications are made to the EUT by the lab during the test.

---END---