



**Eyerising Myopia  
Management Device  
Instructions for Use**

## General Information

Device Name	Eyerising Myopia Management Device	
	RS-200-1A	
	Refer to the label on the device	
	Manufacturer Name:	Eyerising International Pty Ltd
	Address:	Suite 2.05, 9-11 Claremont St. South Yarra, Victoria 3141, Australia
	Phone:	+61 451 386 509
	Email:	liang.lyu@eyerisinginternational.com
	Authorised Representative:	Compliance Management Solutions Europe LTD.
	Address:	2 Bulgaria Str, 2850 Petrich, Bulgaria.

### Symbols for Warnings, Precautionary Measures and Notes

The following conventions are used in this manual:



**WARNING!**

This symbol advises the user of serious danger for the patient and the user.



**CAUTION**

The symbol informs the user that particular care is required for safe and efficient operation of the system.

### Notes on the User Manual

The purpose of the user manual is to familiarize the operator(s) of the Eyerising Myopia Management device lasers with the design, operating principle, transport, installation, set-up, safe operation, safety notes and the care and maintenance of the medical laser device.

## Table of Contents

1.	<b>SYMBOLS &amp; SAFETY SIGNS USED IN THIS MANUAL .....</b>	<b>3</b>
2.	<b>INTRODUCTION.....</b>	<b>5</b>
3.	<b>SYSTEM DESCRIPTION.....</b>	<b>5</b>
4.	<b>TREATMENT.....</b>	<b>8</b>
5.	<b>OPERATING PROCEDURES.....</b>	<b>8</b>
6.	<b>DEVICE SERVICE LIFE.....</b>	<b>14</b>
7.	<b>COMMON FAULTS AND TROUBLESHOOTING.....</b>	<b>14</b>
8.	<b>SAFETY WARNINGS AND PRECAUTIONS.....</b>	<b>15</b>
9.	<b>HANDLING AND MAINTENANCE .....</b>	<b>18</b>
10.	<b>PACKING LIST .....</b>	<b>19</b>
11.	<b>PARAMETERS .....</b>	<b>19</b>
12.	<b>PRODUCT STRUCTURE.....</b>	<b>21</b>
13.	<b>ELECTRICAL INSULATION DIAGRAM .....</b>	<b>21</b>
14.	<b>WARRANTY CARD.....</b>	<b>22</b>

## Table of Figures

Figure 1:	Myopia Management Device - Appearance .....	6
Figure 2:	Power adaptor.....	7
Figure 3:	Welcome Interface .....	9
Figure 4:	Login Interface .....	10
Figure 5:	Wi-Fi Connection Interface.....	10
Figure 6:	Enter Wi-Fi password.....	10
Figure 7:	Login Interface .....	11
Figure 8:	Treatment instruction interface.....	11
Figure 9:	Treatment Interface.....	12
Figure 10:	Red light appearance prior to adjustment .....	12
Figure 11:	Red Light appearance after adjustment .....	13
Figure 12:	Device information page.....	13
Figure 13:	User information page.....	14













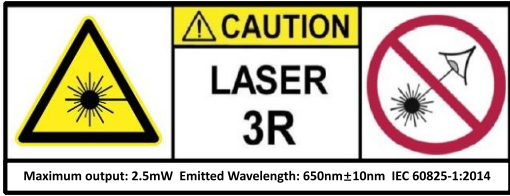







### CAUTION:

This device is a Class 3R laser product. Operators should pay attention to safe use. Safe use measures are throughout the entire manual. Failure to follow the operating instructions, adjustments and repairs in accordance with the instructions in this manual may result in injury to the user.

## 1. SYMBOLS & SAFETY SIGNS USED IN THIS MANUAL

Symbols included in the product include laser warning symbol, electrical safety symbol, packaging symbol, etc.

	Symbols	Definition
1		Laser Warning
2		LASER APERTURE
3		LASER RADIATION AVOID DIRECT EYEEXPOSURE CLASS 3R LASER PRODUCT Maximum output: 2.5mW Emitted Wavelength: 650nm±10nm IEC 60825-1:2014
4		Manufacturer
5		EU authorized representative
6		Date of manufacture
7		Need for the user to consult the instructions for use
8		Class II equipment
9		Type BF applied part
10		Caution

11		CE Marking
12		Keep away from sunlight
13		Protect from sunlight and radioactive sources
14		Keep dry
15		WEEE, Waste Electric and Electronic Equipment; Crossed-out Wheeled Bin
16	<b>IP22</b>	Ingress protection degree
17		Temperature limitations
18		Humidity limitations
19		Atmospheric pressure limitation
20	<b>SN</b>	Serial number
21	<b>REF</b>	Catalogue number
22	<b>MD</b>	Medical Device
23		Importer
24	<b>FCC</b>	FCC mark

## 2. INTRODUCTION

### 2.1. Description

Eyerising Myopia Management Device is a home use medical device which is used for the slowing the progression of myopia in children aged 3-16 years old.

Children with myopia are treated by receiving 3-minutes of red light twice a day with at least one 4-hour interval in between each treatment. The treatment is carried for 5 days per week.



**WARNING:** Children between 3-8 years old must be supervised during use of device. Parents/ guardians need to be able to instruct the children in this age group to take treatment.



**WARNING:** The maximum number of treatments allowed are 10 treatments within 7 consecutive days.



**WARNING:** Children with confirmed retinal diseases should not use this device.

### 2.2. Mode of operation

Eyerising myopia management device emits  $650\text{nm} \pm 10\text{ nm}$  low-level single-wavelength red-light through the diode. The light applies on the ocular fundus of the patients through the pupil and increases the blood flow and metabolism of the ocular fundus. It helps to slow the elongation of the axial length of the eyes, thereby, controls the progression of myopia.

## 3. SYSTEM DESCRIPTION

The device is mainly composed of treatment module, shell, eye mask, interpupillary distance adjustment knob, locking handwheel, touch screen, control circuit and electrical interface (as shown in Figure 1).

The device components and functions are as follows:

- a) Shell: fix and install each component module, which is convenient for users to use the instrument;
- b) Eye mask: The user's eyes are close to the eye mask during treatment, and the eye mask has a good wrap-around property to prevent interference from external light;

- c) Interpupillary distance adjustment knob: The treatment device is a binocular product, and the user can adjust the distance between the launch windows of the treatment device to be consistent with their own interpupillary distance, so as to achieve the best treatment effect;
- d) Locking handwheel: The user adjusts the pitch angle of the treatment head of the device to the best position according to his/her height and posture, and then locks it with the locking handwheel to prevent;
- e) Touch screen: the user operates the machine through the touch screen;
- f) Control circuit: control each electronic module;
- g) Electrical interface: including power switch, power interface, USB interface and LAN interface;
  - i. Power switch: used to start and close the machine;
  - ii. Power interface: connect the adapter for power supply;
  - iii. USB interface: used for manufacturers to detect and debug internal circuits;
  - iv. LAN interface: connect to the external Internet to connect the machine to the external network.
- h) Laser source.
- i) Supplied Accessories: Power adaptor.

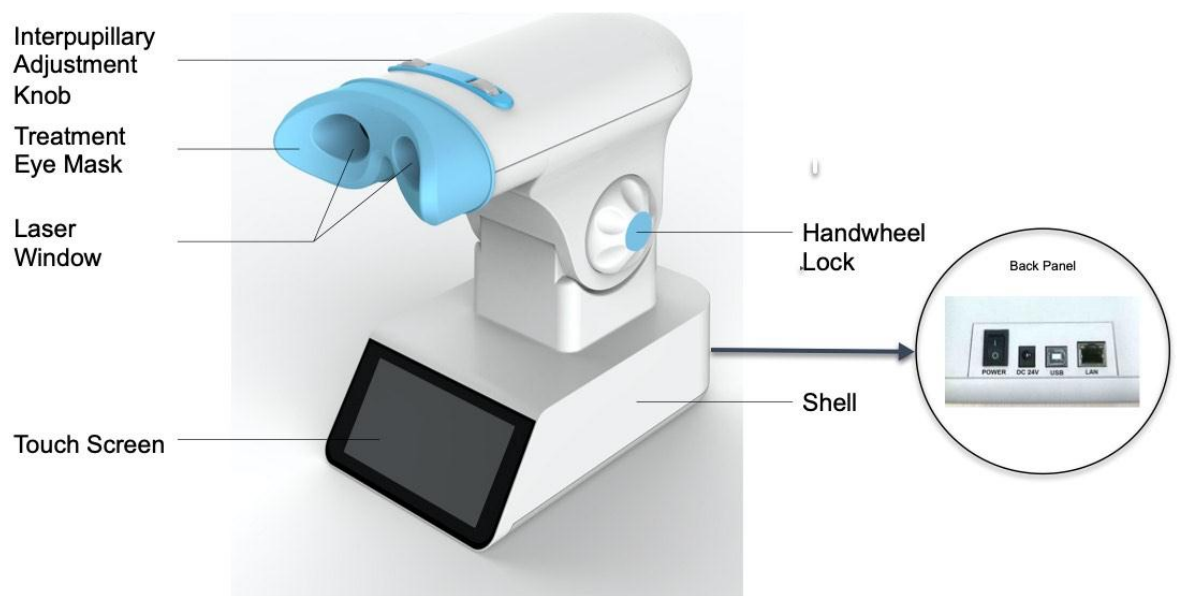

Figure 1: Myopia Management Device - Appearance

### 3.1 Supplied Accessories

- Power Adaptor

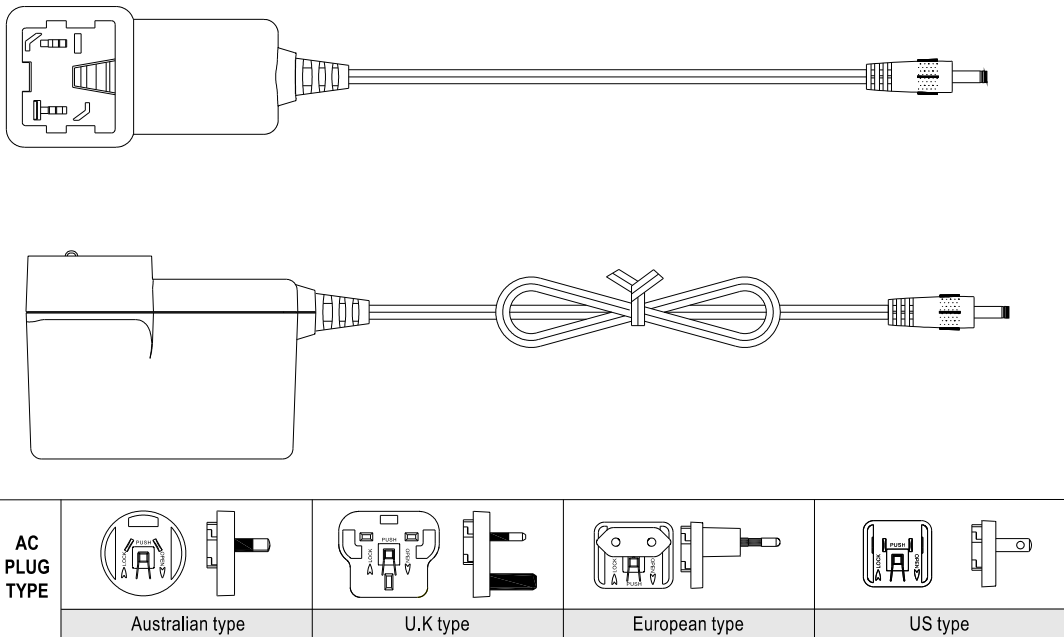

Figure 2: Power adaptor

**NOTE:** The type of the power adaptor AC plug will be supplied based on the market countries.



## 4. TREATMENT

### 4.1. Intended Purpose & Indications

The Eyerising Myopia Management Device is intended to slow the progression of myopia in myopic children aged between 3 and 16 years old. The device is intended to use at home twice a day, 3 minutes each time with at least 4 hours interval in 5 days a week (maximum twice per day and 10 times within 7 days period) under the supervision of parents, by children with myopia.

### 4.2. Intended Target Population

The device's intended users are myopic children aged between 3 and 16 years old. For the children who are not able to use the device independently, their parents will need to provide assistance and supervision.



**WARNING:**

### 4.3. Contra-indications

- Strabismus
- Binocular vision abnormalities in either eye,
- Ocular abnormalities in either eye or other systemic abnormalities
- Children with dilated pupil (mydriasis) or after receiving drugs that can cause dilated pupil such as atropine, cyclopentolate and tropicamide should not use the device.

## 5. OPERATING PROCEDURES



**CAUTION:**

- **Please read the Instructions for use carefully before use to avoid damage to the device or personal safety.**
- **Please use the device under the supervision of parents or guardians. Parents/ guardians must instruct the children between 3-8 years old to take treatment.**

- Colour blind users should use the device under the supervision of parents or guardians.
- Lay person can understand the use of the device after carefully reading the instruction for use.

## 5.1. Device Installation

Unpack the device and place it on a Flat table. The device should be used indoors at home and shall not be moved during use. It is recommended that the height of the tabletop is moderate to ensure that the user can use the device in the most comfortable posture.

Connect the power adapter provided with the device to the DC connector on the device electrical interface and then connect the adapter to a 230V AC power supply at home. Turn on the power switch on the back of the device and follow the steps in the operating instructions to use the device.

## 5.2. Operating Instructions

### 5.2.1 Start

Turn on the power switch & the touch screen lights up. The device enters the welcome screen and login interface, as shown below.



Figure 3: Welcome Interface

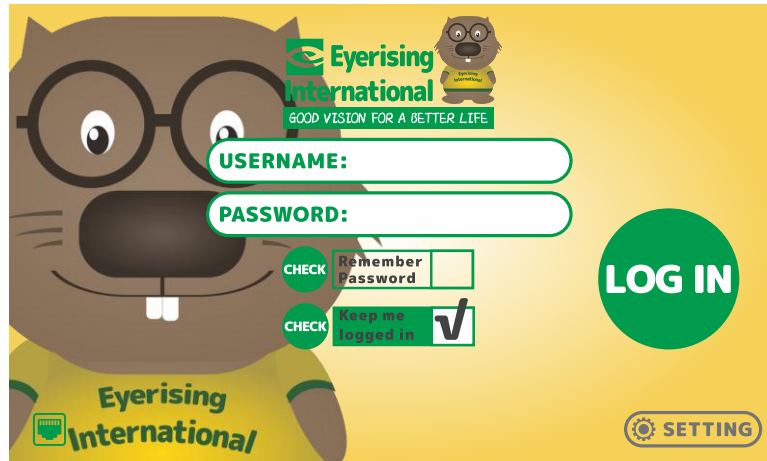

Figure 4: Login Interface

### 5.2.2 Internet Connection

Click “Setting” button at the bottom right of the login interface to enter the Wi-Fi connection interface. Select Wi-Fi and enter the passwords to connect the device to the internet.

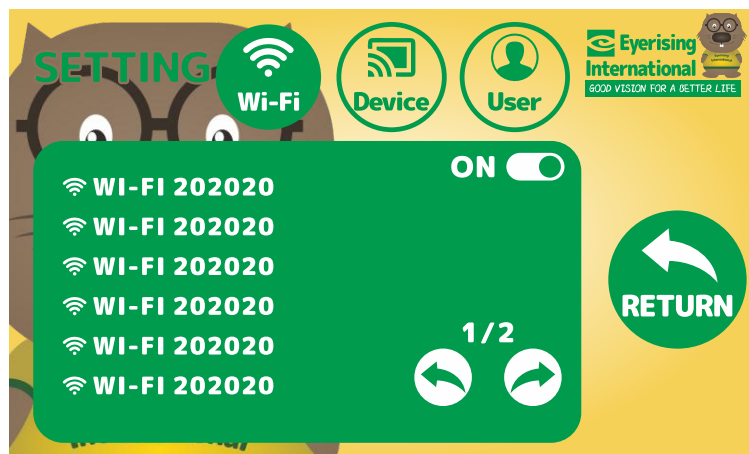

Figure 5: Wi-Fi Connection Interface



Figure 6: Enter Wi-Fi password

### 5.2.3 Login

After connected into the internet, click "RETURN" button in setting interface to go back to the user login interface. Enter the Username and password and click "LOG IN" button. Device enters the treatment interfaces after successful login.

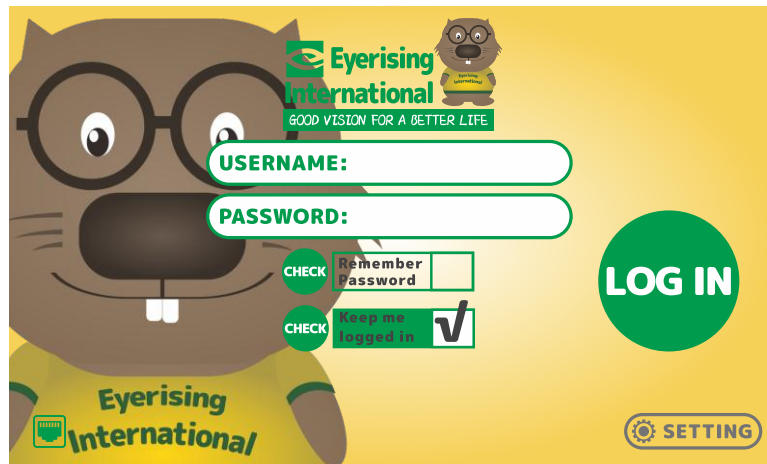

Figure 7: Login Interface

### 5.2.4 Start Treatment

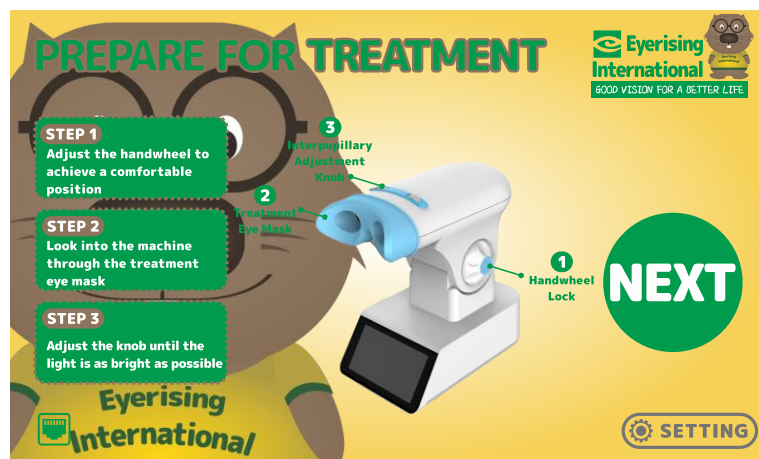

Figure 8: Treatment instruction interface

Read and follow the 3-step instructions on the screen to prepare for treatment:

Step 1: Adjust the handwheel to achieve a comfortable position.

Step 2: Look into the machine through the treatment eye mask.

Step 3: Adjust the knob until the light is as bright as possible.

Click "NEXT" button to enter the treatment interface.

**NOTE:** For the first use, please adjust the light after the start of the treatment in next step.



Figure 9: Treatment Interface

Click “START” button to start the treatment. User shall position eyes close to the device eye mask and look straight into the red emission point(s) in front.

For the first use, please adjust the interpupillary distance at the start of the treatment. Use the grey adjustment knob on top of the device to make the two-way red light emission points merge into one or as bright as possible if the points cannot be adjusted into one.

The red treatment light may look like the image below before adjusting:

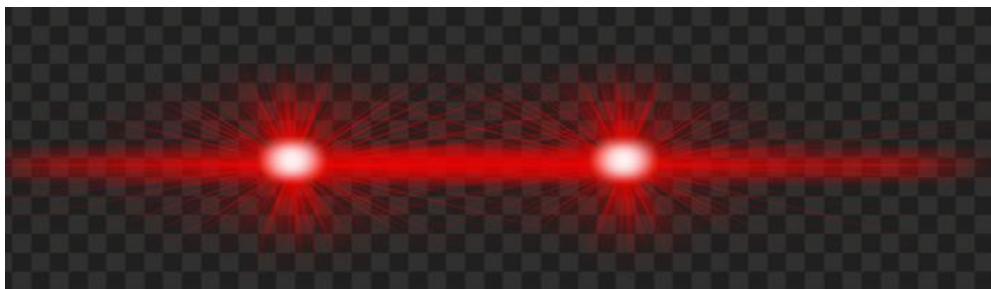

Figure 10: Red light appearance prior to adjustment

After adjusting the knobs, the red treatment light may look like the image below:



Figure 11: Red Light appearance after adjustment

**Note:** If the light emission points do not merge into one for a particular user, the adjustment should be made such that they are as bright as possible.

**Note:** Readjust the light emission point only if required after initial positioning.

**Note:** Please try to keep your eyes open during treatment. The treatment duration is 180 seconds, and the timing information will be displayed at the "Start" button on the interface.

### 5.2.5 User Settings

Click the "Setting" button in right bottom of the screen to enter the device setting interface. User can view device and user information in each interface and can go back to previous page by clicking "RETURN".

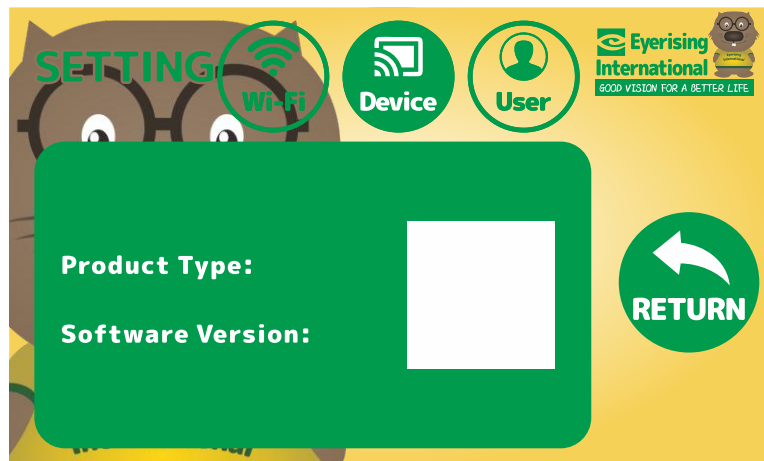

Figure 12: Device information page

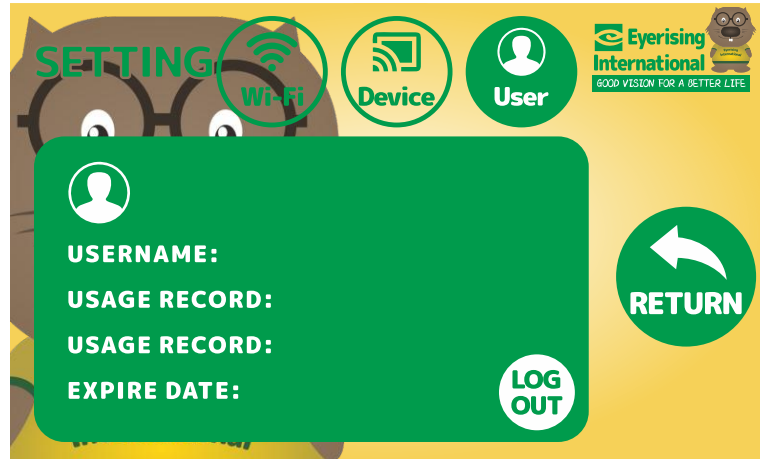



Figure 13: User information page

### 5.2.6 Shut down

After each use, turn off the power switch at the back of the device to the sign of power-off “” and unplug the power adaptor from the power supply.

## 6. DEVICE SERVICE LIFE

- Service life: 5-years
- Maximum time for continuous safe use: 2-years

The Eyerising Myopia Management device has been clinically proven to be safe for continuous use for up to 2-years for any user.

## 7. COMMON FAULTS AND TROUBLESHOOTING

The following table shows the common faults that may occur during the use of the product and troubleshooting methods. If the user encounters such a situation during use, refer to the table below for troubleshooting:

Common Faults	Troubleshooting
Device cannot boot/ start	Power adapter is not connected, or the grid is out of power
No laser radiation or low laser power	Contact manufacturer for repair
The screen does not display anything after starting the device	Contact manufacturer for repair
The touch screen is not sensitive	Contact manufacturer for repair



WARNING: Please contact the manufacturer for repair if the problems persist after troubleshooting.

The following table shows the errors that may occur during the use of the product. The error code includes the cause of the failure. The solution suggested per following table shall be used to correct the error.

Error Display	Solution
Network connection failed	1. Check whether the home network is normal 2. Try to reconnect to the network
Username or password error	Please enter the correct username and password
Control circuit fault	Please contact the manufacturer for repair



WARNING: If you encounter the above errors cannot be eliminated, or if there is an error that is not listed above, please contact manufacturer.

## 8. SAFETY WARNINGS AND PRECAUTIONS

- 8.1. This product is classified as a Class 3R laser product according to IEC60825-1:2014.
- 8.2. The maximum number of treatments allowed are 10 treatments within 7 consecutive days.
- 8.3. For non-patients, it may cause short-term dazzling, flash blindness, and after-images at direct eye exposure.
- 8.4. Non-patient users should avoid direct eye exposure through the laser.
- 8.5. Remove contact lenses or spectacles prior to use of the device.
- 8.6. Use only if you have confirmed myopia diagnosis by eye care clinician.



**CAUTION:** Class 3R LASER RADIATION WHEN OPEN AVOID DIRECT EYE EXPOSURE

- 8.7. Please strictly follow the operation instructions on this manual to use treatment. Harmful laser irradiation may be caused if do not follow this operation instruction method.
- 8.8. Side effects may include glare, flash blindness or afterimages. If the symptoms persist, stop using the device and seek advice from the healthcare professional.



8.9. It is unsafe to:

- use ACCESSORIES, detachable parts and materials not described in the instructions for use;
- interconnect this equipment with other equipment not described in the instructions for use;
- modify the equipment;

#### Use Environment

8.10. The device is intended to be used indoors at home and shall not be moved during use.

Please do not use the device outdoors and expose the device to dust, dirt and rain.

8.11. Use of accessories and cables other than those specified or provided by the manufacturer of this equipment could result in increased electromagnetic emissions or decreased electromagnetic immunity of this equipment and result in improper operation.

8.12. Portable and radio frequency communication equipment may affect this product.

8.13. Do not expose the device to magnetic fields, external electrical influences, electrostatic discharge, pressure or variations in pressure, acceleration, thermal ignition sources, etc.

#### Operation

8.14. The device is intended to use twice a day with at least four hours interval and in five days a week. The software will lock the treatment function after 10 times use within 7 days to protect the safety of the user. Please do not use the device more than advised.

8.15. Do not remove the eye mask or laser window.

8.16. Ensure that during treatment, eyes are kept in front of the eye mask.

8.17. Do not use the device beyond 2-years. The device maximum safe use time is 2 years.

8.18. Please follow the instructions of healthcare professional when using the Myopia management device.

8.19. If any discomfort such as light sensitivity, eye irritation or eye burn occur while using this product, stop using it or follow the healthcare professional's advice.

8.20. Pay attention to eye hygiene during treatment and stop using this product if you have eye diseases such as eye inflammation and swelling.

8.21. After each use, please turn off the power switch, and then unplug the power plug.

8.22. Connection to IT-networks including other equipment could result in unidentified risks.

## 9. HANDLING AND MAINTENANCE

### 9.1. General

- 1) When not in use, please store the device and accessories properly to prevent them from being subjected to strong shocks or vibrations.
- 2) Avoid exposure to water or other liquids into the product.
- 3) Do not expose the machine and accessories to high temperature, high humidity, dust, or direct sunlight.
- 4) Do not disassemble the product shell, and do not replace parts without authorization.
- 5) After using the device for 2 years, return the device to Eyerising International for laser inspection and maintenance.

**Note:** The contact details for Eyerising International are given at the first page of this instructions.

### 9.2. Disposal:

The Myopia Management Device is Waste Electric and Electronic Equipment (WEEE) and should not be mixed with general household waste. When the device is approaching 5-year service life or the aging is accelerated due to special reasons, the user should always pay attention to the state of the machine and contact the local authority to determine the proper method of disposal.



WEEE must be sent to separate collection facilities for recovery and recycling.

### 9.3. Cleaning

If you find dust or pollution on the shell, eye mask or window, you can use a soft cloth dipped in water to wring dry and wipe gently. If necessary, use absorbent cotton dipped in alcohol to wipe gently. Any screen cleaner may be used to clean touchscreen.

### 9.4. Transport and Storage

- 1) The device package must be handled with care. Device and all accessories should be stored properly to prevent damage.
- 2) During transportation, the device should be packed in the manufacturer provided special packaging box with moisture-proof outer packaging and soft materials inner packaging.
- 3) Transportation and storage conditions:

- a) Temperature range:  $-25^{\circ}\text{C}$ — $+70^{\circ}\text{C}$ ;

Note:

- There is no time required for ME EQUIPMENT to warm from the minimum storage temperature between uses until it is ready for intended use
- There is time no required for ME EQUIPMENT to cool from the maximum storage temperature between uses until it is ready for intended use

- b) Relative humidity: 15%—90% (non-condensing);

- c) Atmospheric pressure: 700hPa—1060 hPa;

## 10. PACKING LIST

1) Eyerising Myopia Management Device	One
2) Power Adapter	One
3) Instructions for Use	One
4) Warranty card	One

## 11. PARAMETERS

### 11.1. Laser:

	Parameter	Specification
a.	Nature	Diode laser
b.	Type	Class 3R
c.	Laser wavelength $\lambda$	650nm $\pm$ 10nm
d.	Output laser power (Pc)	2.0mW $\pm$ 0.5mW
e.	Maximum output	2.5mW
f.	Instability of output power	$\leq$ 10%
g.	Launch duration	180s $\pm$ 10s
h.	Divergence angle (degree)	2.1 $^{\circ}$ $\pm$ 0.1 $^{\circ}$
i.	The spot diameter of the output laser at the observation port	10mm $\pm$ 2mm
j.	Pulse width and repetition frequency	Continuous transmission

### 11.2. Safety indicators:

	Parameter	Specification
a.	Operation mode	continuous operation
b.	Electrical safety classification	Class II Type BF applied part
c.	Ingress protection level	IP22
d.	Device Weight	2.1Kg $\pm$ 0.2kg (package not included)
e.	Dimensions	34 $\times$ 18 $\times$ 32 cm (length x width x height)

### 11.3. Working/Operating conditions:

	Parameter	Specification
a.	Ambient temperature	+5 $^{\circ}$ C $\sim$ +40 $^{\circ}$ C
b.	Relative humidity	15%—90% (non-condensing)
c.	Atmospheric pressure	800hPa—1060 hPa
d.	Rated operating altitude (a) m	$\leq$ 2 000
e.	Rated power supply	<ul style="list-style-type: none"> <li>• Main unit: 24V d.c., 1.25A</li> <li>• Adaptor: input: 100-240Va.c. 50Hz/60Hz, 1.0-0.6A; output: 24Vd.c., 1.25A</li> </ul>

#### 11.4. Transportation and storage conditions:

	Parameter	Specification
a.	Temperature range	-25°C—+70°C
b.	Relative humidity	15%—90% (non-condensing)
c.	Atmospheric pressure	700hPa—1060 hPa

## 12. PRODUCT STRUCTURE

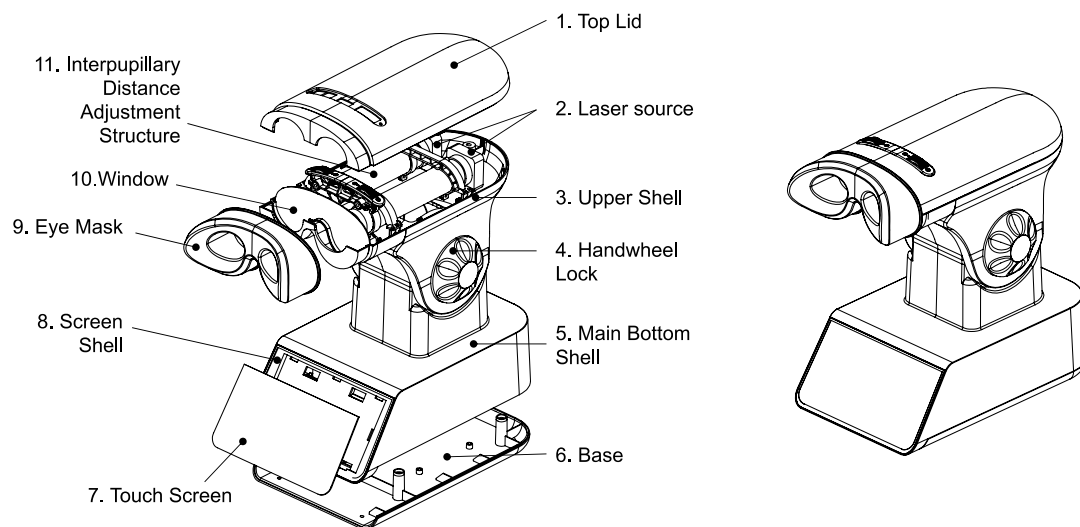

## 13. ELECTRICAL INSULATION DIAGRAM

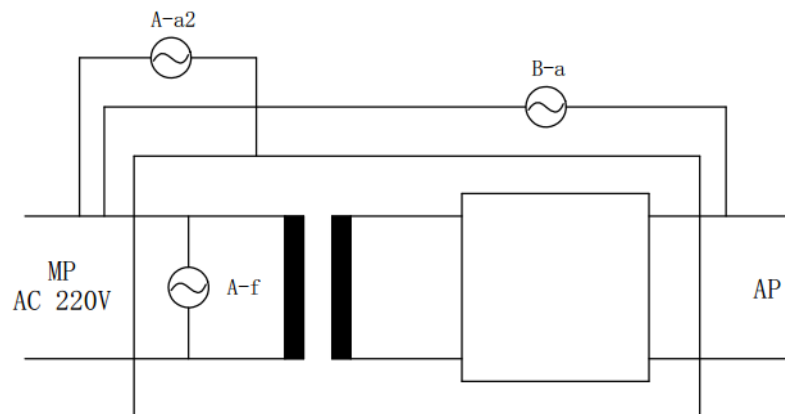

## 14. WARRANTY CARD

### WARRANTY NOTICE

1. This warranty card is for the products of Eyerising International as the scope of warranty.
2. Failures that occur during normal use of the product during the warranty period can be sent to our designated maintenance centre for repair together with this card. If the damage to the product is caused by the following reasons, it will be charged a repair fee.
  - a. Accidental factors or human behaviour, such as damage, falling, mechanical damage, water ingress, etc.
  - b. Damage caused by force majeure factors (lightning, earthquake, fire and other natural disasters).
3. The company reserves the right of final interpretation and decision.

Username		Phone	
Mailing Address			
Purchase Date		Product Name	
Model Specification		Product Number	

#### FCC Statement

Changes or modifications not expressly approved by the party responsible for compliance could void the user's authority to operate the equipment.

This equipment has been tested and found to comply with the limits for a Class B digital device, pursuant to Part 15 of the FCC Rules. These limits are designed to provide reasonable protection against harmful interference in a residential installation. This equipment generates uses and can radiate radio frequency energy and, if not installed and used in accordance with the instructions, may cause harmful interference to radio communications. However, there is no guarantee that interference will not occur in a particular installation. If this equipment does cause harmful interference to radio or television reception, which can be determined by turning the equipment off and on, the user is encouraged to try to correct the interference by one or more of the following measures:

- Reorient or relocate the receiving antenna.
- Increase the separation between the equipment and receiver.
- Connect the equipment into an outlet on a circuit different from that to which the receiver is connected.
- Consult the dealer or an experienced radio/TV technician for help

This device complies with part 15 of the FCC rules. Operation is subject to the following two conditions (1) this device may not cause harmful interference, and (2) this device must accept any interference received, including interference that may cause undesired operation.

This equipment complies with FCC radiation exposure limits set forth for an uncontrolled environment.