

THERMAL PRINTER

# **USER'S MANUAL**

# Table of Contents

EN .....	2
FR .....	13
DE .....	24
IT .....	35
ES .....	46

# Product list



Printer

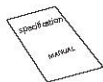

Manual



Data cable

# Product introduction

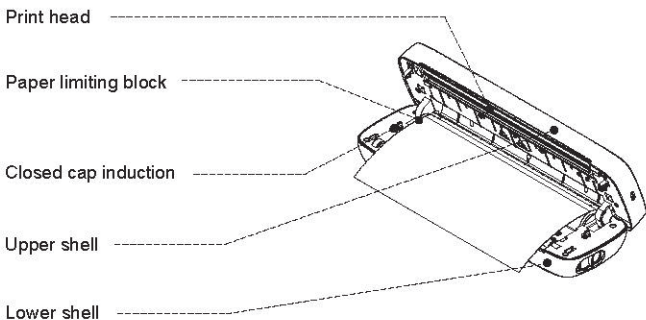

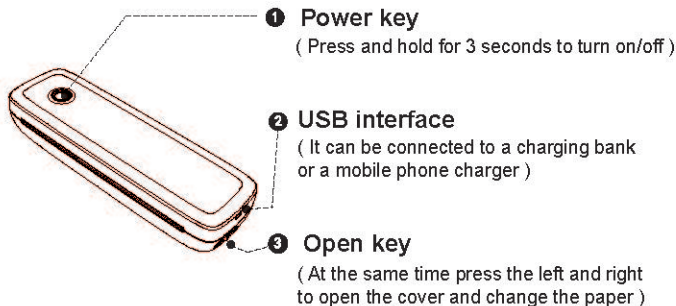

## LED Status

Light	Description	Troubleshoot
Green	Normal operation	
Red	a. Printer head is overheated b. Charging c. Top cover open d. No paper	a. Printer will automatically resume once the printer head has cooled down. b. When fully charged, the light turns green. c. Close the top cover correctly.
Flashing Red	Low electric quantity	Please charge the printer
Blue	BT pairing success	BT connected success
Flashing Blue	BT is initializing or initialization failed	please close the app first, restart the printer, wait for the blue light to no longer flash, and then connect the printer in the app

# App download and connect

## Download

1. Search the App Store/Google Play for "**Luck Jingle**" download
2. Scan the corresponding QR code to download



ios



Android

## Connect device

Please Long press the **power** button until the blue light flashes and enter the "**Luck Jingle**" App, turn on the BT of the mobile phone



Ios phone: please turn on the mobile phone **BT**

Android phone: please turn on the mobile phone **BT** and **GPS**



1. Click the small printer icon in the upper right corner
2. Click to search for BT
3. Click to connect
4. Successfully connected, a small green icon is displayed in the upper right corner

Note: Do not search for the printer connection in the Bluetooth settings of the mobile phone, but turn on the BT function and search for related devices in the APP and then connect it.

# Driver download

Driver download Please download the printer driver ( Window or MAC ) on the official website at:  
<http://www.luckjingle.com/driverDetail?id=5>

## Install the driver for Windows

Turn on the printer, The printer connects to the computer via USB, Locate the downloaded

" **L81 Windows Driver** " file and open it.

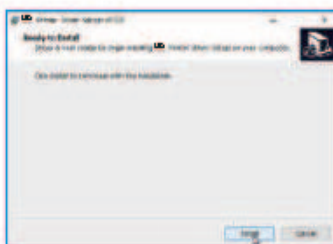

1. Click the " Install " button and wait for installation

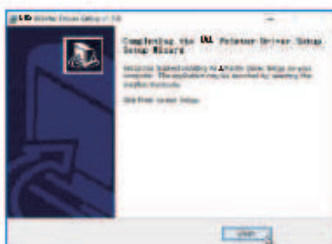

2. After the installation is successful, click " Finish " to exit the interface

Note: Before installing the driver, turn off your computer antivirus software.the printer needs to be connected to the power supply and computer, and the power on state.

## Install the driver for MAC

Turn on the printer, The printer connects to the computer via USB, Locate the downloaded

"**L81 Windows Driver**" file and open it.

1. Click on "**open**" and continue to install the printer.

Follow the installation tip until you see "**The installation was successful**"

2. Set the printer as the default mode. Please follow the steps in the picture to cooperate:

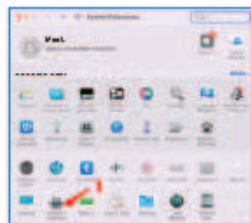

1. Open the System Preferences, click on "Printers & Scanners"



2. Click here to add a printer, fax or scanner

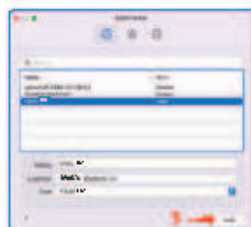

3. Select YXWL L81 USB, click "Add" to add the printer



4. As shown in the figure, complete the printer setup



# Roll paper installation guide

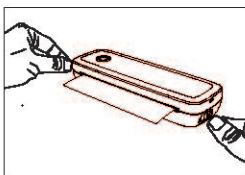

1. Open cover

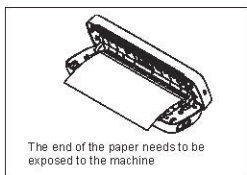

The end of the paper needs to be exposed to the machine

2. Lay down paper

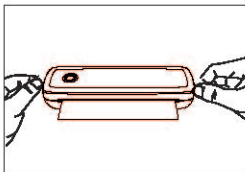

3. Closing cap

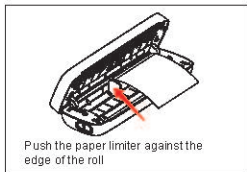

Push the paper limiter against the edge of the roll

4. Paper limiter is used

# Foldable paper installation guide

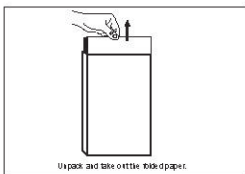

Unpack and take out little folded paper.

1. Unpack

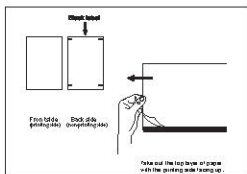

Front side (printing side)

Back side (nonprinting side)

Take out the top layer of paper with the printing side facing up.

2. Take out paper

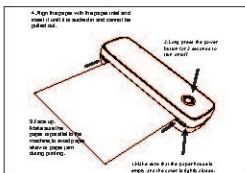

Align the paper with the paper inlet and make it level if it is wavy and cannot be pulled out.

1. Lay flat the paper based on the guide in the tray.

2. Lay on the paper on the paper inlet and make it level if it is wavy and cannot be pulled out.

3. Make sure that the paper is aligned with the paper inlet.

3. Loading paper

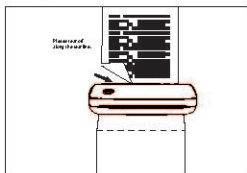

Front side (printing side)

4. Tear paper

## Charging instructions

1. It is recommended to use mobile phone charger to charge, 5V/2A input charge
2. It is recommended to charge the first time after purchase
3. Charge once every three months, otherwise it is easy to cause lithium battery, long time natural loss, and can not charge the phenomenon

## Warning

1. In a residential environment, running this device may cause radio interference
2. The factory standard of this product does not include a power adapter. If you use a power adapter to charge, you should purchase one CE certified 5V/2A power adapter that meets the standards
3. This is a professional product, please use the original battery.
4. If you replace the original battery or use the wrong one Model batteries may explode.

# Safety and precautions

1. There is a built-in lithium battery, please do not use it in the environment with temperature higher than 40 °C; keep away from fire and other heat sources, and do not place it in the hot sun, such as closed car;
2. Children should be charged and used under the supervision of adults. After full charge, please make sure to pull out the charging line in time to prevent overheating, short circuit or fire;
3. Do not put the product in fire or water to avoid battery short circuit or fire or burn;
4. Working environment :0°C-40°C ambient temperature, relative humidity, 30%-85% RH Use in ( non-condensing ) environment, please do not exceed the recommended temperature range.
5. If you suspect that there is a problem with the battery, please contact the after-sales service center for assistance.

 Please do not touch the print head directly to avoid damage, especially after printing, do not touch the print head directly to prevent overheating and scalding.

# Cleaning print head



1. Please shut down the printer, open the paper cover and take out the paper roll
2. Dip cotton cloth or cotton swabs into it. On the medical alcohol, along the printing head center to around the direction of gently wipe
3. After cleaning the print head, do not use the printer immediately. Please wait 1' 2 minutes until the alcohol has completely evaporated.

# Product specification

Product model	L81
Printing mode	Row heat sensitive
Printing speed	10 mm/s ( max )
Input power	5V $\equiv$ 2A
Machine size	290 x 90 x 56.5 mm
Weight	756 g
Paper type	Thermal Paper
Roll paper size	210*30mm
Foldable paper size	A4: 210*297mm / Letter: 216*279mm
Instruction format	YPL
Graphic printing	Support
Man-machine interface	Key LED indicator drive
Communication interface	USB / BT2.0 & BT4.0
Operating temperature (C)	0°C ~ +40°C
Working humidity	30% ~ 85% RH ( no condensation )
Storage temperature (C)	-20°C ~ +60°C

# Liste des produits



Imprimante

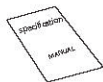

Manual



Câble de données

# Introduction du produit

Tête d'impression

Bloc de limitation de papier

Bouchon fermé induction

Coque supérieure

Coque inférieure

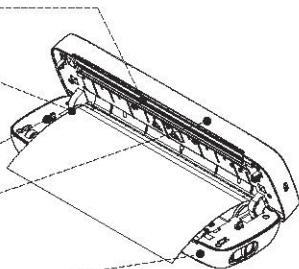

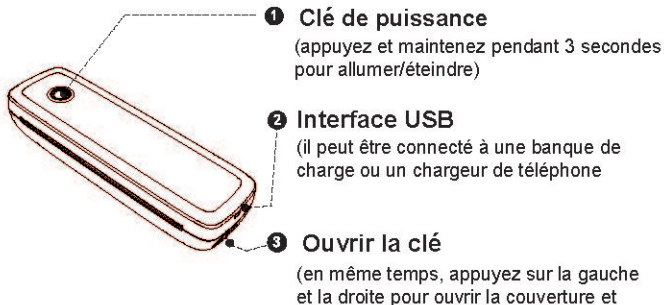

## Statut de LED

lumière	Description Description	dépannage
vert	Fonctionnement Normal	
rouge	a. Printer head is overheated b. Charging c. Top cover open d. No paper	A. L'imprimante automatiquement Reprendre une fois la tête de l'imprimante refroidie. B. Une fois entièrement chargé, La lumière devient verte. C. Fermez la couverture supérieure correctement.
clignotant rouge	Basse quantité électrique	Veillez charger l'imprimante
bleu	Succès du jumelage BT	BT connecté à succès
clignotant bleu	BT initialise ou L'initialisation a échoué	Veillez fermer l'application Tout d'abord,reatart l'imprimante, attendre que la lumière bleue ne clignoter plus, puis connecter l'imprimante dans l'application

# App télécharger et se connecter

## Télécharger le document

1. Rechercher dans l'app Store/Google Play pour "**Luck Jingle**" télécharger
2. Scannez le code QR correspondant pour télécharger



ios



Android

## Connecter l'appareil

S'il vous plaît appuyez longtemps sur le bouton d'alimentation jusqu'à ce que la lumière bleue clignote et entrez dans l'application "**Luck Jingle**" App., allumez le BT du téléphone mobile

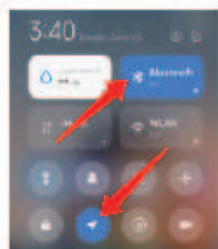

Téléphone ios: s'il vous plaît allumer le téléphone portable BT

Téléphone Android: s'il vous plaît allumer le téléphone portable BT et GPS





1. Cliquez sur l'icône de petite imprimante dans le coin supérieur droit
2. Cliquez pour rechercher BT
3. Cliquez pour vous connecter
4. Connecté avec succès, une petite icône verte s'affiche dans le coin supérieur droit

Remarque: ne cherchez pas la connexion de l'imprimante dans les paramètres Bluetooth du téléphone mobile, mais activez la fonction BT et recherchez les appareils connexes dans l'application, puis connectez-la.

## Télécharger le pilote

Téléchargement du pilote veuillez télécharger le pilote de l'imprimante

(Window ou MAC) sur le site officiel à:

<http://www.luckjingle.com/driverDetail?id=5>

## Installer le pilote pour Windows

Allumez l'imprimante, l'imprimante se connecte à l'ordinateur via USB, localisez le téléchargé

"Pilote Windows L81" fichier et l'ouvrir.

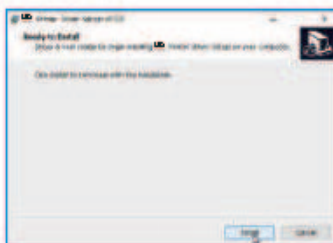

1. Cliquez sur le bouton "installer" et attendez l'installation



2. Après l'installation est réussie, Cliquez sur «terminer» pour quitter l'interface

Remarque: avant d'installer le pilote, éteignez votre logiciel antivirus. L'imprimante doit être connectée à l'alimentation d'énergie et à l'ordinateur, et à l'état de mise sous tension.

# Installer le pilote pour MAC

Allumez l'imprimante, l'imprimante se connecte à l'ordinateur via USB, localisez le téléchargé

**"Pilote Windows L81"** fichier et l'ouvrir.

1. Cliquez sur «ouvrir» et continuez à installer l'imprimante.

Suivez le conseil d'installation jusqu'à ce que vous voyez "l'installation a été un succès"

2. Définissez l'imprimante comme mode par défaut. S'il vous plaît suivre the steps in the picture to operate :



1. Ouvrez les préférences système, cliquez sur "Imprimantes et Scanners"



2. Cliquez ici pour ajouter une imprimante, un fax ou un scanner



3. Sélectionnez YXVM L81 USB, Cliquez sur «ajouter» pour ajouter l'imprimante

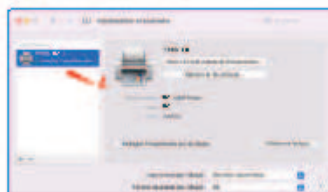

4. Comme le montre la figure, terminez la configuration de l'imprimante

# Guide d'installation de papier de rouleau

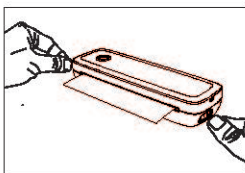

1. Couverture ouverte

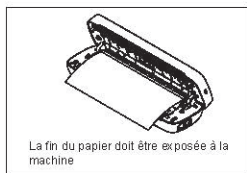

La fin du papier doit être exposée à la machine

2. Poser le papier

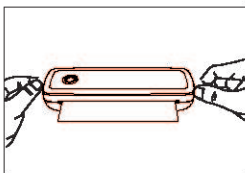

3. Bouchon de fermeture

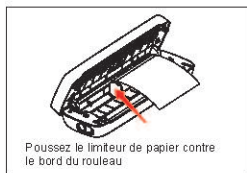

Poussez le limiteur de papier contre le bord du rouleau

4. Un limiteur de papier est utilisé

# Guide d'installation de papier pliable

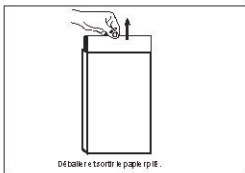

Déballer et tordre le papier plié.

1. décompresser

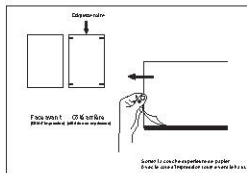

2. Pour emporter page

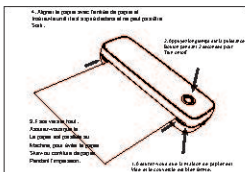

4. Aligner le papier avec l'indicateur de papier et ne pas pousser trop.

2. Appuyer pour pousser sur le papier et laisser aller et s'écarter pour l'air chaud.

Si il est un peu tendu, appuyez-vous contre le papier et couvrez la machine, puis laissez le papier s'échapper complètement. Pendant l'impression.

1.6. assurez-vous de régler le papier en haut et le couvrir au lieu d'être.

3. Chargement du page

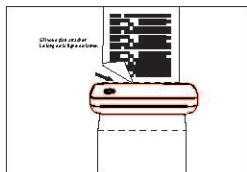

Offrez des modèles d'usage et d'application.

4. Papier lame

# Instructions de charge

1. Il est recommandé d'utiliser le chargeur de téléphone portable pour charger, charge d'entrée 5V/2A
2. Il est recommandé de charger la première fois après l'achat
3. Chargez une fois tous les trois mois, autrement il est facile de causer la batterie au lithium, perte naturelle de long temps, et ne peut pas charger le phénomène

## avertissement

1. Dans un environnement résidentiel, l'exécution de cet appareil peut causer des interférences radio
2. La norme d'usine de ce produit n'inclut pas un adaptateur secteur. Si vous utilisez un adaptateur secteur pour charger, vous devez acheter un adaptateur secteur 5V/2A certifié CE qui répond aux normes
3. C'est un produit professionnel, s'il vous plaît utiliser la batterie d'origine.
4. Si vous remplacez la batterie d'origine ou utilisez le mauvais modèle, les batteries peuvent exploser.

# Sécurité et précautions

1. Il y a une batterie au lithium intégrée, s'il vous plaît ne l'utilisez pas dans l'environnement avec une température supérieure à 40 °C; Gardez loin du feu et d'autres sources de chaleur, et ne le placez pas au soleil chaud, comme la voiture fermée;
2. Les enfants doivent être accusés et utilisés sous la surveillance d'adultes. Après une charge complète, assurez-vous de retirer la ligne de charge à temps pour empêcher la surchauffe, le court-circuit ou le feu;
3. Ne mettez pas le produit dans le feu ou l'eau pour éviter le court-circuit de batterie ou le feu ou la brûlure;
4. Environnement de travail: température ambiante de 0°C-40°C, humidité relative, utilisation de 30%-85% hr dans l'environnement (sans condensation), veuillez ne pas dépasser la plage de température recommandée.

 S'il vous plaît ne touchez pas la tête d'impression directement pour éviter des dommages, surtout après l'impression, ne touchez pas la tête d'impression directement pour éviter la surchauffe et



1. Veuillez arrêter l'imprimante, ouvrir la couverture de papier et retirer le rouleau de papier
2. Tremper un chiffon de coton ou des tampons de coton dedans. Sur l'alcool médical, le long du centre de la tête d'impression à autour de la direction de essuyer doucement
3. Après avoir nettoyé la tête d'impression, n'utilisez pas l'imprimante immédiatement. Veuillez patienter 1' 2 minutes jusqu'à ce que l'alcool se soit complètement évaporé.

# Spécification du produit

Modèle de produit	L81
Mode d'impression	Row chaleur sensible
Vitesse d'impression	10 mm/ S (max)
Puissance d'entrée	5V $\equiv$ 2A
Taille de Machine	Dimensions: 290 x 90 x 56.5mm
Poids poids	756 g
Type de papier	Papier thermique
Taille de papier de rouleau	210*30mm
Format de papier pliable	A4: 210*297mm / La lettre: 216*279mm
Format d'instruction	YPL
Impression graphique	soutien
Interface homme-machine	Clé LED indicateur drive
Interface de Communication	USB / BT2.0 & BT4.0
Température de fonctionne- ment (C)	0°C ~ +40°C
Humidité fonctionnante	-20°C ~ +60°C



# Produktliste

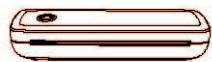

Drucker

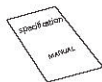

Handbuch



Data cable

# Produkteinführung

Druckkopf

Papierbegrenzungsblock

Induktion mit geschlossener Kappe

Oberschale

Untere Schale

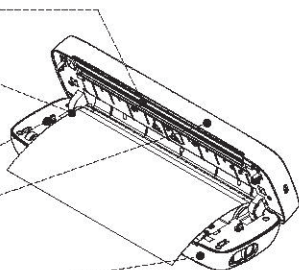



## LED-Status

licht	Beschreibung	Fehlerbehebung
Grün	Normalbetrieb	
Rot	a. Der Druckkopf ist überhitzt b. Gebühren c. obere Abdeckung offen d. Kein Papier	a. Drucker wird automatisch Fahren Sie fort, sobald der Druckkopf abgekühlt ist. b. Bei voller Ladung Licht wird grün. c. Schließen Sie die obere Abdeckung richtig. supérieure correctement.
Blinken Rot	Geringe elektrische Menge	Bitte laden Sie den Drucker auf
Blau	BT-Kopplung erfolgreich	BT-Verbindung erfolgreich
Blinken Blau	BT wird initialisiert oder Initialisierung fehlgeschla- gen	Bitte schließen Sie die App Stellen Sie zuerst den Drucker neu an, warten Sie, bis das blaue Licht nicht mehr blinkt, und verbinden Sie dann den Drucker in der App

# App herunterladen und verbinden

## Télécharger le document

1. Suchen Sie im App Store/Google Play nach "Luck Jingle" herunterladen
2. Scannen Sie den entsprechenden QR-Code zum



ios



Android

## Gerät anschließen

Bitte lange die Ein-/Aus-Taste drücken, bis das blaue Licht blinkt und die "Luck Jingle" App aufrufen, BT des Mobiltelefons einschalten

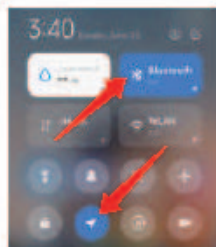

ios Telefon: Bitte schalten Sie das Mobiltelefon BT ein Bluetooth

Android-Telefon: Bitte schalten Sie das Mobiltelefon BT und GPS ein



1. Klicken Sie auf das kleine Druckersymbol in der oberen rechten Ecke
2. Klicken Sie, um nach BT zu suchen
3. Zum Verbinden klicken
4. Erfolgreich verbunden, wird ein kleines grünes Symbol in der oberen rechten Ecke angezeigt

Achtung: sucht nicht in den bluetooth-einstellungen nach verbindungen, sondern in BT, danach in einer APP.

## Treiber herunterladen

Treiber herunterladen Bitte laden Sie den Druckertreiber herunter

(Fenster oder MACauf der offiziellen Website unter:

<http://www.luckjingle.com/driverDetail?id=5>

## Den Treiber für Windows installieren

Schalten Sie den Drucker ein, Der Drucker verbindet sich mit dem Computer über USB, Suchen Sie die heruntergeladene

**"L81 Windows Driver** File und öffnen Sie sie.

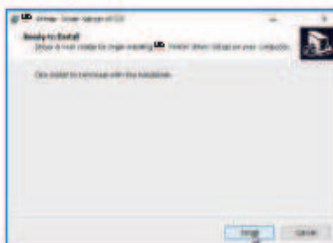

1. Klicken Sie auf die Schaltfläche Installations-Taste und warten Sie auf die



2. Nach erfolgreicher Installation, Klicken Sie auf "Fertig stellen" um die Schnittstelle zu verlassen.

Hinweis: Bevor Sie den Treiber installieren, schalten Sie die Antivirensoftware Ihres Computers aus. Der Drucker muss an das Netzteil und den Computer angeschlossen sein, und der

## Treiber für MAC installieren

Schalten Sie den Drucker ein, Der Drucker verbindet sich mit dem Computer über USB, Suchen Sie die heruntergeladene

**"L81 Windows Driver** File und öffnen Sie sie.

1. Klicken Sie auf die Schaltfläche "Öffnen" und fahren Sie mit der Installation des Druckers fort.

Folgen Sie den Installationstipps, bis Sie Folgendes

2. Stellen Sie den Drucker als Standardmodus ein.  
die Schritte im Bild zur Bedienung:



1. Öffnen Sie die Systemeinstellungen, klicken Sie auf "Drucker für



2. Klicken Sie hier, um einen Drucker, Fax oder Scanner hinzuzufügen



3. Wählen Sie YXWL L81 USB, Klicken Sie auf "Hinzufügen" um den Drucker hinzuzufügen



4. Wie in der Abbildung gezeigt, schließen Sie die Druckereinrichtung ab

# Richtlinien zur installation Von filzpapier

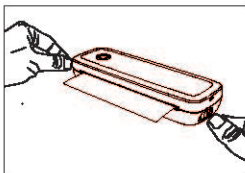

1. Wir machen einen versicherungsvertrag klar.

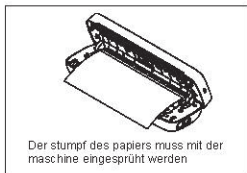

Der stumpf des papiers muss mit der maschine eingesprüht werden

2. Ein holzladen.

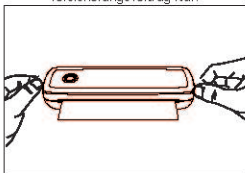

3. Mütze schließen.

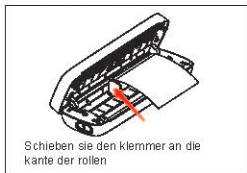

Schieben sie den klemmer an die kante der rollen

4. Mit einem klebeband

# Falten zur installation Von anleitungen

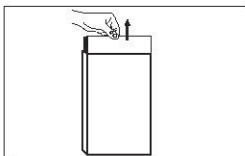

Öffnen sie die packung und nehmen sie die gefalteten blätter heraus.

1. Kabel lösen.

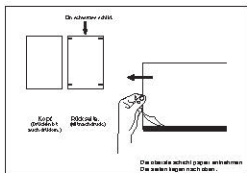

Die oberste schicht papier entnehmen Die seiten legen nach oben.

2. Pack die tüte ein.

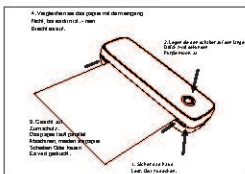

3. Vollladen, pepper!

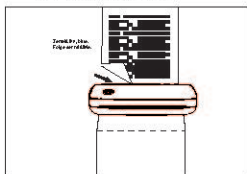

4. Das papier zerreißen.

# Ladeanleitung

1. Es wird empfohlen, Handy-Ladegerät zu verwenden, um aufzuladen, 5V/2A Eingangsladung
2. Es wird empfohlen, das erste Mal nach dem Kauf zu laden
3. Laden Sie einmal alle drei Monate, sonst ist es einfach, Lithiumbatterie, langfristigen natürlichen Verlust zu verursachen und kann das Phänomen nicht aufladen

# Warnung

1. In einer Wohnumgebung kann der Betrieb dieses Geräts Funkstörungen verursachen
2. Der Werksstandard dieses Produkts beinhaltet kein Netzteil. Wenn Sie ein Netzteil zum Aufladen verwenden, sollten Sie ein CE-zertifiziertes 5V/2A-Netzteil kaufen, das die Standards erfüllt
3. This ist ein professionelles Produkt, bitte verwenden Sie die ursprüngliche Batterie.
4. Wenn Sie die Originalbatterie austauschen oder die falsche verwenden, können Modellbatterien explodieren.



# Sicherheit und Vorsichtsmaßnahmen

1. Es gibt eine eingebaute Lithiumbatterie, bitte verwenden Sie sie nicht in der Umgebung mit Temperatur höher als 40 °C; Halten Sie sich von Feuer und anderen Wärmequellen fern und stellen Sie es nicht in die heiße Sonne, wie geschlossenes Auto;
2. Kinder sollten unter Aufsicht von Erwachsenen berechnet und verwendet werden. Nach vollständiger Ladung stellen Sie bitte sicher, dass Sie die Ladeleitung rechtzeitig herausziehen, um Überhitzung, Kurzschluss oder Feuer zu verhindern;
3. Setzen Sie das Produkt nicht in Feuer oder Wasser, um Batteriekurzschluss oder Feuer oder Verbrennung zu vermeiden;
4. Arbeitsumgebung: 0°C-40°C Umgebungstemperatur, relative Luftfeuchtigkeit, 30%-85% RH Verwendung in nichtkondensierender Umgebung, bitte überschreiten Sie nicht den empfohlenen Temperaturbereich.

 Please do not touch the print head directly to avoid damage, especially after printing, do not touch the print head directly to prevent overheating and scalding.

# Reinigung des Druckkopfes



1. Bitte schließen Sie den Drucker, öffnen Sie die Papierabdeckung und nehmen Sie die Papierrolle heraus
2. Tauchen Sie Baumwolltuch oder Wattestäbchen hinein.
3. Verwenden Sie den Drucker nach der Reinigung des Druckkopfs nicht sofort. Bitte warten Sie 1' 2 Minuten, bis der Alkohol vollständig verdampft ist.

# Produktspezifikation

Produktmodell	L81
Druckmodus	Reihe hitzeempfindlich
Druckgeschwindigkeit	10 mm/s,max)
Eingangsleistung	5V= 2A
Maschinengröße	290 x 90 x 56.5mm
Gewicht	756 g
Papierart	Thermopapier
Größe eines rolle.	210*30mm
Papier kann man falten	A4: 210*297mm / Briefe: 216*279mm
Instruktionsformat	YPL
Grafischer Druck	Unterstützung
Mensch-Maschine	Taste LED Anzeigeantrieb
Schnittstelle	USB / BT2.0 & BT4.0
Kommunikationsschnittstelle	0°C ~ +40°C
Betriebstemperatur (C)	30% ~ 85% RH, keine Kondention)
Arbeitsfeuchte	-20°C ~ +60°C

## Elenco prodotti



Stampante

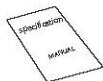

Manuale



Cavo dati

## Introduzione del prodotto

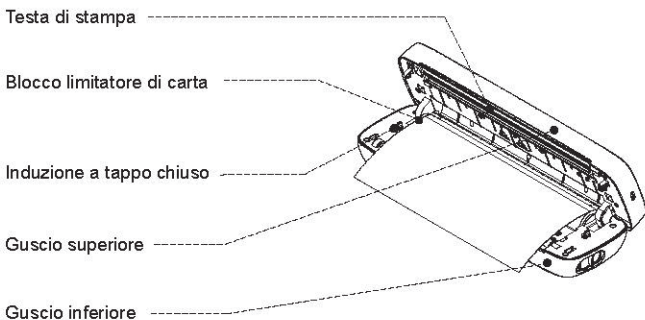

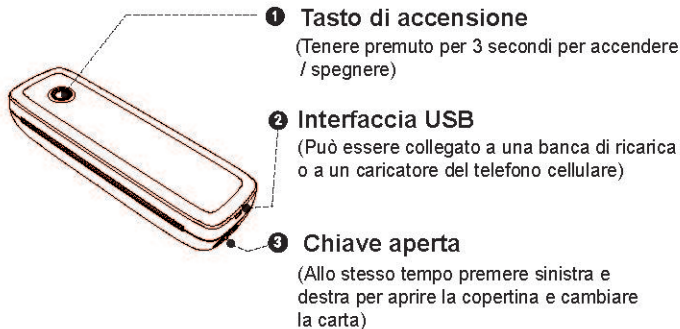

## Stato LED

Luce	Descrizione	Risoluzione dei problemi
Verde	Funzionamento normale	
Rosso	a. La testina della stampante è surriscaldata b. Oneri c. Coperchio superiore	a. La stampante verrà automaticamente Riprendere una volta che l'intestazione della stampante si è raffreddata. b. Una volta completamente carica, il La luce diventa verde. c. Chiudere correttamente la copertura superiore.
Lampeggiante Rosso	Quantità elettrica bassa	Si prega di caricare la stampante
Blu	Successo dell'accoppiamento BT	BT connected success
Lampeggiante Blu	BT sta avviando o inizializzazione non riuscita	please close the app first,reatart the printer,wait for the blue light to no longer flash,and then connect the printer in the app

# Scarica e connetti App

## Scarica

1. Cerca nell'App Store/Google Play per "**Luck Jingle**" download
2. Scansiona il codice QR corrispondente per scaricare



ios



Android

Collegare il dispositivo Premere a lungo il pulsante di accensione fino a quando la luce blu lampeggia e entrare nell'app "**Luck Jingle**", accendere il BT del telefono cellulare

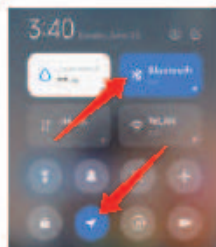

ios telefono: si prega di accendere il telefono cellulare **BT**

telefono Android: si prega di accendere il telefono cellulare **BT** e **GPS**



1. Fare clic sull'icona della stampante piccola nell'angolo in alto a destra
2. Fare clic per cercare BT
3. Fare clic per connettersi
4. Collegato correttamente, una piccola icona verde viene visualizzata nell'angolo in alto a destra

Nota: non cercare la connessione della stampante nelle impostazioni Bluetooth del cellulare, ma accendere la funzione BT e cercare i dispositivi collegati nella APP e poi connetterli.

## Scaricare driver

Scarica il driver Scarica il driver della stampante (Finestra o MAC ) sul sito ufficiale all'indirizzo:

<http://www.luckjingle.com/driverDetail?id=5>

## Installare il driver per Windows

Accendere la stampante, La stampante si collega al computer tramite USB, Individuare il file scaricato

" **L81 Windows Driver** " file e aprirlo.

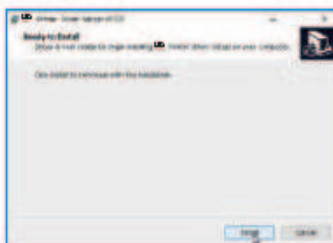

1. Fare clic sul pulsante "Installa" e attendere l'installazione



2. Dopo che l'installazione è riuscita, Fare clic su "Finish" per uscire dall'interfaccia

Nota: Prima di installare il driver, spegnere il software antivirus del computer. La stampante deve essere collegata all'alimentazione elettrica e al computer e allo stato di accensione.



## Installa il driver per MAC

Accendere la stampante, La stampante si collega al computer tramite USB, Individuare il file scaricato

"**L81 Windows Driver**" file e aprirlo.

1. Fare clic su "**open**" e continuare a installare la stampante.  
Seguire il suggerimento di installazione fino a visualizzare "L'installazione"
2. Impostare la stampante come modalità predefinita.  
le fasi illustrate per operare:



1. Aprire le Preferenze di Sistema, fare clic su "Stampanti e scanner"



2. Clicca qui per aggiungere una stampante, fax o scanner

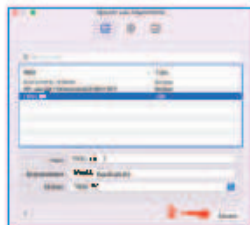

3. Selezionare YXWL L81 US B, Fare clic su "Aggiungi" per aggiungere la stampante



4. Come mostrato in figura, completare la configurazione della stampante

# Guida all'installazione di carta rotante

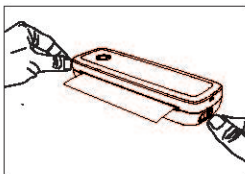

1. Apri copertina



La fine della carta deve essere esposta alla macchina

2. Crea carta

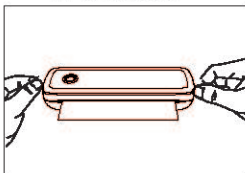

3. Chiusura cap

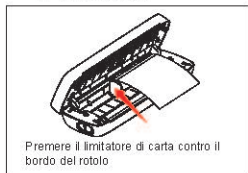

Premere il limitatore di carta contro il bordo del rotolo

4. Si usa un limitatore di carta

# Guida all'installazione di carta pieghevole

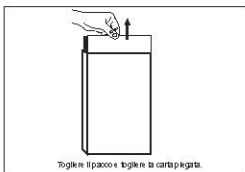

Togliere il pacco e togliere la carta piegata.

1. estrazione

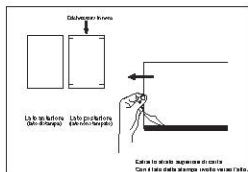

Calare lo strato superiore di carta con il lato della stampa rivolto verso l'alto.

2. Togli fuori la pape

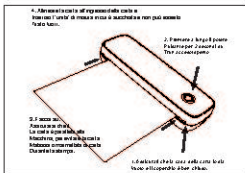

1. Allevare la carta e all'ingressare nella carta e inserire l'angolo di misura prima di assicurarsi non può essere fatto bene.

2. Premere a lungo il pannello Paper for Journal or Text accordingly.

3.5. Acciaio.  
Prestare attenzione.  
La carta è piegata alla sinistra, per evitare il ripiegamento e l'impedimento della carta durante la stampa.

4. Assicurarsi che il lato della carta sia allineato con il lato dell'angolo della carta.

3. Caricamento pape

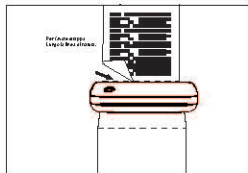

Per l'installazione  
Larghezza carta.

4. Strappa carta

# Istruzioni per la ricarica

1. Si raccomanda di utilizzare il caricatore del telefono cellulare per caricare, carica di ingresso 5V/2A
2. Si consiglia di caricare la prima volta dopo l'acquisto
3. caricare una volta ogni tre mesi, altrimenti è facile causare la batteria al litio, perdita naturale di lungo tempo e non può caricare il fenomeno

## Attenzione

1. In un ambiente residenziale, l'utilizzo di questo dispositivo può causare interferenze radio
2. Lo standard di fabbrica di questo prodotto non include un adattatore di alimentazione. Se si utilizza un adattatore di alimentazione per ricaricare, è necessario acquistare un adattatore di alimentazione 5V / 2A certificato CE che soddisfa gli standard
3. This è un prodotto professionale, si prega di utilizzare la batteria originale.
4. Se si sostituisce la batteria originale o si utilizza quella sbagliata Le batterie modello potrebbero esplodere.

# Sicurezza e precauzioni

Sicurezza e precauzione1. C'è una batteria al litio integrata, si prega di non usarlo nell'ambiente con temperatura superiore a 40 °C; tenere lontano dal fuoco e da altre fonti di calore e non metterlo al sole caldo, come l'automobile chiusa;

2. I bambini devono essere addebitati e utilizzati sotto la supervisione di adulti. Dopo la carica completa, assicurarsi di estrarre la linea di ricarica in tempo per evitare surriscaldamento, cortocircuito o incendio;

3. non mettere il prodotto in fuoco o acqua per evitare cortocircuito della batteria o incendio o bruciare;

4. ambiente di lavoro: 0 ° C-40 ° C temperatura ambiente, umidità relativa, 30% -85% RH Uso in ambiente (non condensante), si prega di non superare l'intervallo di temperatura raccomandato.

5. Se si sospetta che ci sia un problema con la batteria, si prega di contattare il centro di assistenza post-vendita per assistenza.

 Si prega di non toccare direttamente la testina di stampa per evitare danni, soprattutto dopo la stampa, non toccare direttamente la testina di stampa per evitare surriscaldamento e

## Testina di stampa di pulizia



1. Si prega di spegnere la stampante, aprire il coperchio di carta e prendere il rotolo di carta
2. immergere panno di cotone o tamponi di cotone in esso. Sull'alcool medico, lungo il centro della testa di stampa intorno alla direzione di pulire delicatamente
3. Dopo aver pulito la testina di stampa, non utilizzare immediatamente la stampante. Si prega di attendere 1' 2 minuti fino a quando l'alcol è completamente evaporato.

# Specifiche del prodotto

Modello di prodotto	L81
Modalità di stampa	Sensibile al calore della riga
Velocità di stampa	10 mm/s ( max )
Potenza in ingresso	5V $\equiv$ 2A
Dimensione macchina	290 x 90 x 56.5 mm
Peso	756 g
Tipo di carta	Carta termica
Stampa dimensione carta	210*30mm
Dimensione della carta pieghevole	A4: 210*297mm / lettera: 216*279mm
Formato delle istruzioni	YPL
Stampa grafica	Supporto
Interfaccia uomo-macchina	Indicatore LED chiave
Interfaccia di comunicazione	USB / BT2.0 & BT4.0
Temperatura di esercizio (C)	0 $^{\circ}$ C ~ +40 $^{\circ}$ C
Umidità di lavoro	30% ~ 85% RH (senza condensa)
Temperatura di conservazione (C)	-20 $^{\circ}$ C ~ +60 $^{\circ}$ C

# Lista de productos



Impresoras

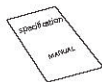

Manual



Cable de datos

## Introducción del producto

Cabeza de impresión

Bloque de restricción de papel

Inducción cerrada

Carcasa superior

Carcasa inferior

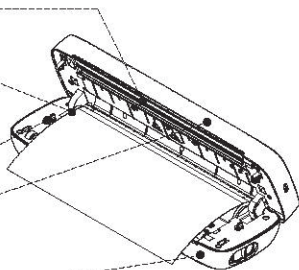



## Estado LED

Luz	Descripción	Preguntas y respuestas difíciles
Verde	Funcionamiento normal	
Rojo	Sobrecalentamiento de la cabeza de impresión Carga C. Se abre la tapa superior D. sin papel	A. la impresora será automática Continúe después de que la nariz de la impresora se enfríe. B. cuando está completamente cargado Las luces se vuelven verdes. Cierre correctamente la cubierta superior.
Parpadeo Rojo	Baja electricidad	Por favor, cargue la impresora
Azul	Emparejamiento BT exitoso	Conexión BT exitosa
Parpadeo Azul	BT se está iniciando o Falló la iniciación	Por favor, cierre la aplicación Primero, reinicie la impresora, espere a que la luz azul deje de parpadear y luego conecte la impresora en la aplicación



# Descarga y conexión de aplicaciones

## Descargar

1. buscar en la tienda de aplicaciones / Google Play

Descarga "**Luck Jingle**"

2. escanee el Código QR correspondiente para



ios



Android

## Dispositivos conectados

Presione el botón de encendido durante mucho tiempo hasta que la luz azul parpadee, luego ingrese a la aplicación

"**Luck Jingle**" y abra el BT del teléfono.

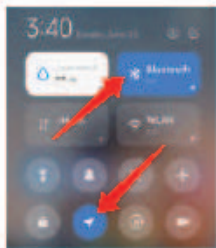

teléfono ios: por favor, encienda el **BT** del teléfono

teléfono android: abra el **BT** y el **GPS** del teléfono



1. haga clic en el icono de la pequeña impresora en la esquina superior derecha
2. haga clic para buscar BT
3. haga clic para conectarse
4. conexión exitosa, con un pequeño icono verde en la

Nota: no busque la conexión de la impresora en los ajustes Bluetooth del teléfono móvil, sino que active la función BT y busque dispositivos relacionados en la aplicación y conéctelo.

## Descarga del conductor

Descargar el controlador descargar descargar el controlador de la impresora

(ventana o mac) en el sitio web oficial:

<http://www.luckjingle.com/driverDetail?id=5>

## Instalar el controlador de Windows

Abre la impresora, la impresora se conecta a la computadora a través de USB y encuentra la descarga

El archivo "**L81 Windows driver**" y ábrelo.

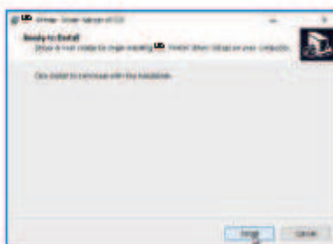

1. haga clic en el botón "instalar" y espere a instalar

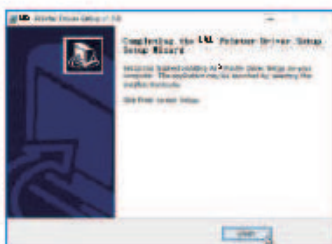

2. después de la instalación exitosa, Haga clic en "completar" para salir de la interfaz

Nota: antes de instalar el controlador, apague el software antivirus del ordenador. la impresora necesita conectarse a la fuente de alimentación y al ordenador y estar encendida.

## Instalar el controlador de Mac

Abre la impresora, la impresora se conecta a la computadora a través de USB y encuentra la descarga

El archivo "**L81 Windows driver**" y ábrelo.

1. haga clic en "**abrir**" y continúe instalando la impresora. Siga las indicaciones de instalación hasta ver "**instalación** Éxito "
2. establezca la impresora en modo predeterminado. siga Pasos en la imagen:



1. abra las preferencias del sistema y haga clic en "impresoras y



3. seleccione el Y XML L81 USB, Haga clic en "añadir" para agregar



2. haga clic aquí para agregar una impresora, fax o escáner



4. complete la configuración de la impresora como se muestra en la imagen.

# Guía de instalación de rollo de papel

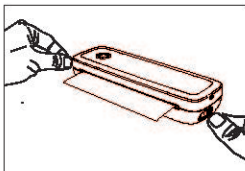

1. Cubierta abierta



El extremo del papel debe exponerse a la máquina

2. El papel

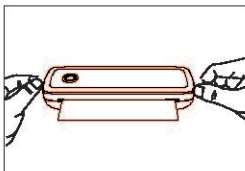

3. Tapa de cierre

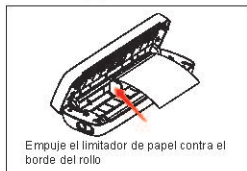

Empuje el limitador de papel contra el borde del rollo

4. Se utiliza un limitde papel

# Guía de instalación de papel plegable

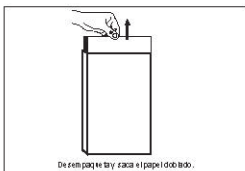

De empaque tray saca el papel doblado.

1. desempaquete

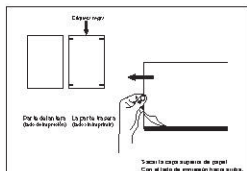

Saca la carga superior de papel. Con el lado de impresión hacia arriba.

2. Sacar el papel

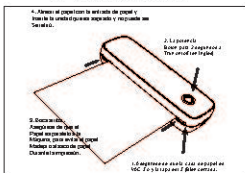

4. Retira el capotón la entrada de papel y hazlo la única fijación superior y respaldar en Sereno.

3. Sacar arriba. Asegúrese de que el papel sea que está la hoja. Mantenga, como en el papel. Añade a la zona de papel. De arriba empacón.

2. La parte de la parte superior. De arriba empacón.

1. El empacón está. Con el papel en la parte superior en el área central.

3. Carga de las hojas de carga

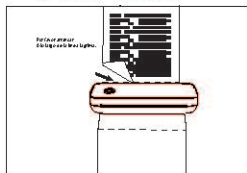

Por favor asegure el papel en la parte superior.

4. Papel de lágrima

## Instrucciones de carga

1. se recomienda cargar con un cargador de teléfono móvil y cargar con entrada 5v / 2A
2. se recomienda cargar por primera vez después de la compra
3. cargar cada tres meses, de lo contrario es fácil causar pérdidas naturales a largo plazo de la batería de litio y no se puede cargar.

## Aviso

1. en un entorno residencial, el funcionamiento de este dispositivo puede causar interferencias de radio
2. el estándar de fábrica de este producto no incluye adaptadores de alimentación. Si recargas con un conector de alimentación, debes comprar un conector de alimentación 5v / 2A certificado que cumpla con los estándares.
3. este es un producto profesional, por favor use la batería original.
4. si se reemplaza la batería original o se utiliza la batería incorrecta, la batería modelo puede explotar.

# Seguridad y precauciones

1. baterías de litio incorporadas, no las use en ambientes con temperaturas superiores a 40 ° c; Manténgase alejado de la fuente de fuego y otras fuentes de calor y no lo coloque bajo el sol abrasador, como un automóvil cerrado;
2. los niños deben cargar y usar bajo la supervisión de adultos. Después de cargar, asegúrese de sacar el cable de carga a tiempo para evitar sobrecalentamiento, cortocircuito o incendio;
3. no coloque el producto en fuego o agua para evitar cortocircuitos o incendios o quemaduras en la batería;
4. ambiente de trabajo: temperatura ambiente de 0 ° C - 40 ° c, humedad relativa, 30% - 85% RH para uso en ambiente (no condensado), no exceda el rango de temperatura recomendado.
5. si sospecha que hay un problema con la batería, Póngase en contacto con el Centro de servicio post - venta para obtener ayuda.

 No toque la cabeza de impresión directamente para evitar daños, especialmente después de la impresión, no toque la cabeza de la impresora directamente para evitar sobrecalentamientos y quemaduras.

# Limpiar la cabeza de impresión



1. cierre la impresora, abra la cubierta de papel y retire el rollo de papel
2. sumerja con un algodón o un hisopo de algodón. en alcohol medicinal, limpie suavemente a lo largo del Centro de la cabeza de impresión hacia los alrededores.
3. no use la impresora inmediatamente después de limpiar la cabeza de impresión. Espere 1 / 2 minutos hasta que el alcohol se evapore por completo.



# Especificaciones del producto

Modelo de producto	L81
Modo de impresión	Sensibilidad térmica de la línea
Velocidad de impresión	10 mm / S (máximo)
Potencia de entrada	5V $\approx$ 2A
Tamaño de la máquina	290 x 90 x 56.5mm
Peso	756 gramos
Tipo de papel	Papel térmico
Tamaño del papel	210*30mm
Tamaño de papel plegable	A4: 210*297mm / carta: 216*279mm
Formato de instrucción	YPL
Impresión gráfica	Apoyo
Interfaz hombre - máquina	Unidad de indicador LED de clave
Interfaz de comunicación	USB / BT2.0 & BT4.0
Temperatura de funcionamiento (c)	0 ° C ~ + 40 ° C
Humedad de trabajo	30% - 85% RH (sin condensación)
Temperatura de almacenamiento (c)	- 20 ° C ~ + 60 ° C

## FCC Statement

This device complies with Part 15 of the FCC Rules. Operation is subject to the following two conditions:

(1) This device may not cause harmful interference.  
(2) This device must accept any interference received, including interference that may cause undesired operation.

2. Changes or modifications not expressly approved by the party responsible for compliance could void the user's authority to operate the equipment.

Note: This equipment has been tested and found to comply with the limits for a class B digital device, pursuant to Part 15 of the FCC Rules. These limits are designed to provide reasonable protection against harmful interference in a residential installation.

This equipment generates uses and can radiate radio frequency energy and, if not installed and used in accordance with the instructions, may cause harmful interference to radio communications. However, there is no guarantee that interference will not occur in a particular installation. If this equipment does cause harmful interference to radio or television reception, which can be determined by turning the equipment off and on, the user is encouraged to try to correct the interference by one or more of the following measures:

- Reorient or relocate the receiving antenna.
- Increase the separation between the equipment and receiver.
- Connect the equipment into an outlet on a circuit different from that to which the receiver is connected.
- Consult the dealer or an experienced radio/TV technician for help.

The device has been evaluated to meet general RF exposure requirement. The device can be used in portable exposure condition without restriction.



ios



Android



[www.luckjingle.com](http://www.luckjingle.com)

Made in China