

**ELECTROMAGNETIC EMISSIONS COMPLIANCE REPORT
INTENTIONAL RADIATOR CERTIFICATION TO
FCC PART 15 SUBPART C REQUIREMENT**

OF

A4 Thermal Printer

Model No.: L81, A80, A81, 4187, L81S, L81H

Trademark: N/A

FCC ID: 2A74A-A4

Report No.: E01A23090586F00101

Issue Date: October 17, 2023

Prepared for

Xiamen Lujiang Technology Co., Ltd.

**Room 601-2, No.63-1, Wanghai Road, Software Park Phase II, Torch
Hi-Tech Zone, Xiamen, China**

Prepared by

Guangdong Global Testing Technology Co., Ltd.

**Room 101-105, 203-210, Building 1, No.2, Keji 8 Road, Songshan Lake
Park, Dongguan city, Guangdong, People's Republic of China, 523808**

**This report shall not be reproduced, except in full, without the written approval of
Guangdong Global Testing Technology Co., Ltd.**

VERIFICATION OF COMPLIANCE

Applicant:	Xiamen Lujiang Technology Co., Ltd. Room 601-2, No.63-1, Wanghai Road, Software Park Phase II, Torch Hi-Tech Zone, Xiamen, China
Manufacturer:	Xiamen Lujiang Technology Co., Ltd. Room 601-2, No.63-1, Wanghai Road, Software Park Phase II, Torch Hi-Tech Zone, Xiamen, China
Product Description:	A4 Thermal Printer
Trade Mark:	N/A
Model Number:	L81, A80, A81, 4187, L81S, L81H (Note: All models are the same, except the model name.)
Sample number:	A23090586 001

We hereby certify that:

The above equipment was tested by Guangdong Global Testing Technology Co., Ltd. The test data, data evaluation, test procedures, and equipment configurations shown in this report were made in accordance with the procedures given in ANSI C63.10-2013 and the energy emitted by the sample EUT tested as described in this report is in compliance with conducted and radiated emission limits of FCC Rules Part 15.247(2021).

Prepared By:

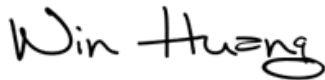

Win Huang
Project Engineer

Checked By:



Alan He
Laboratory Leader

Approved By:



Shawn Wen



Modified Information

Version	Summary	Revision Date	Report No.
Ver.1.0	Original Report	/	E01A23090586F00101

Table of Contents

1.	GENERAL INFORMATION	6
1.1	PRODUCT DESCRIPTION	6
1.2	TEST METHODOLOGY	6
1.3	TEST FACILITY	7
2.	SYSTEM TEST CONFIGURATION.....	8
2.1	EUT CONFIGURATION	8
2.2	EUT EXERCISE	8
2.3	TEST PROCEDURE	8
2.4	CONFIGURATION OF TESTED SYSTEM.....	9
3.	SUMMARY OF TEST RESULTS.....	10
4.	DESCRIPTION OF TEST MODES	11
5.	TEST SYSTEM UNCERTAINTY.....	12
6.	CONDUCTED EMISSIONS TEST	13
6.1	MEASUREMENT PROCEDURE:.....	13
6.2	TEST SET-UP (BLOCK DIAGRAM OF CONFIGURATION)	13
6.3	MEASUREMENT EQUIPMENT USED:.....	13
6.4	MEASUREMENT RESULT:	13
6.5	CONDUCTED MEASUREMENT PHOTOS:	16
7.	RADIATED EMISSION TEST.....	17
7.1	MEASUREMENT PROCEDURE	17
7.2	TEST SET-UP (BLOCK DIAGRAM OF CONFIGURATION).....	19
7.3	MEASUREMENT EQUIPMENT USED:	20
7.4	RADIATED EMISSION LIMIT.....	21
7.5	MEASUREMENT RESULT	22
7.5	RADIATED MEASUREMENT PHOTOS:.....	30
8.	CHANNEL SEPARATION TEST	31
8.1	MEASUREMENT PROCEDURE	31
8.2	TEST SET-UP (BLOCK DIAGRAM OF CONFIGURATION).....	31
8.3	MEASUREMENT EQUIPMENT USED:	31
8.4	MEASUREMENT RESULTS:.....	31
9.	20DB BANDWIDTH TEST.....	37
9.1	MEASUREMENT PROCEDURE	37
9.2	TEST SET-UP (BLOCK DIAGRAM OF CONFIGURATION).....	37
9.3	MEASUREMENT EQUIPMENT USED:	37
9.4	MEASUREMENT RESULTS:	37
10.	QUANTITY OF HOPPING CHANNEL TEST.....	43
10.1	MEASUREMENT PROCEDURE	43
10.2	TEST SET-UP (BLOCK DIAGRAM OF CONFIGURATION)	43
10.3	MEASUREMENT EQUIPMENT USED:	43
10.4	MEASUREMENT RESULTS:.....	43

11. TIME OF OCCUPANCY (DWELL TIME) TEST 46

11.1 TEST DESCRIPTION 46

11.2 TEST SET-UP (BLOCK DIAGRAM OF CONFIGURATION) 46

11.3 MEASUREMENT EQUIPMENT USED: 46

11.4 TEST REQUIREMENTS / LIMITS 46

11.5 TEST RESULT 48

12. MAXIMUM PEAK OUTPUT POWER TEST 58

12.1 MEASUREMENT PROCEDURE 58

12.2 TEST SET-UP (BLOCK DIAGRAM OF CONFIGURATION) 58

12.3 MEASUREMENT EQUIPMENT USED: 58

12.4 MEASUREMENT RESULTS: 59

13. BAND EDGE TEST 64

13.1 MEASUREMENT PROCEDURE 64

13.2 TEST SET-UP (BLOCK DIAGRAM OF CONFIGURATION) 65

13.3 MEASUREMENT EQUIPMENT USED: 65

13.4 MEASUREMENT RESULTS: 66

14. ANTENNA APPLICATION 87

14.1 ANTENNA REQUIREMENT 87

14.2 RESULT 87

1. GENERAL INFORMATION

1.1 Product Description

Characteristics	Description
Product Name	A4 Thermal Printer
Model number	L81, A80, A81, 4187, L81S, L81H (Note: All models are the same, except the model name.)
Input rating	5V $\overline{=}$ 2A
Power Supply	DC 5V from adapter or battery 7.2V
Kind of Device	Bluetooth V5.2
Modulation	GFSK, $\pi/4$ -DQPSK, 8DPSK
Operating Frequency Range	2402-2480MHz
Number of Channels	79
Transmit Power Max(PK)	4.34dBm(0.0027W)
Antenna Type	PCB Antenna
Antenna Gain	3.14dBi
Sample Received Date	September 25, 2023

1.2 Test Methodology

Both conducted and radiated testing was performed according to the procedures in ANSI C63.10-2013. Radiated testing was performed at an antenna to EUT distance 3 meters.

1.3 Test Facility

Site Description

EMC Lab. : **A2LA (Certificate No.: 6947.01)**
Guangdong Global Testing Technology Co., Ltd.
has been assessed and proved to be in compliance with A2LA.
FCC (FCC Designation No.: CN1343)
Guangdong Global Testing Technology Co., Ltd.
has been recognized to perform compliance testing on
equipment subject to Supplier's Declaration of Conformity
(SDoC) and Certification rules

Note: All tests measurement facilities use to collect the measurement data are located at Room 101-105, 203-210, Building 1, No.2, Keji 8 Road, Songshan Lake Park, Dongguan city, Guangdong, People's Republic of China, 523808

2. System Test Configuration

2.1 EUT Configuration

The EUT configuration for testing is installed on RF field strength measurement to meet the Commissions requirement and operating in a manner which intends to maximize its emission characteristics in a continuous normal application.

2.2 EUT Exercise

The Transmitter was operated in the normal operating mode. The Tx frequency was fixed which was for the purpose of the measurements.

2.3 Test Procedure

2.3.1 Conducted Emissions

The EUT is placed on a turn table which is 0.8 m above ground plane. According to the requirements in Section 13.1.4.1 of ANSI C63.10-2013. Conducted emissions from the EUT measured in the frequency range between 0.15 MHz and 30MHz using CISPR Quasi-Peak and average detector mode.

2.3.2 Radiated Emissions

Below 1000MHz, The EUT was placed on a turn table which is 0.8m above ground plane. And above 1000MHz, The EUT was placed on a styrofoam table which is 1.5m above ground plane. The turn table shall rotate 360 degrees to determine the position of maximum emission level. EUT is set 3m away from the receiving antenna which varied from 1m to 4m to find out the highest emission. And also, each emission was to be maximized by changing the polarization of receiving antenna both horizontal and vertical. In order to find out the max. emission, the relative positions of EUT was fixed in a particular direction according to the requirements in Section 13.1.4.1 of ANSI C63.10-2013.

2.4 Configuration of Tested System

Fig. 2-1 Configuration of Tested System

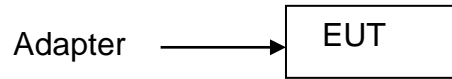

Table 2-1 Equipment Used in Tested System

Item	Equipment	Trademark	Manufacturer	Model No.	FCC ID	Note
1.	A4 Thermal Printer	N/A	Xiamen Lujiang Technology Co., Ltd.	L81	2A74A-A4	EUT
2.	AC/DC ADAPTER	N/A	Shenzhen Keyu Power Supply Technology Co.,LTD	KA06E-0502000US	N/A	Support EUT

Note:

- (1) Unless otherwise denoted as EUT in 『Remark』 column , device(s) used in tested system is a support equipment.

3. Summary of Test Results

FCC Rules	Description Of Test	Result
§15.207	AC Power Conducted Emission	Compliant
§15.247(d),§15.209, §15.205	Radiated Emission	Compliant
§15.247(a)(1)	Channel Separation test	Compliant
§15.247(a)(1)	20dB Bandwidth	Compliant
§15.247(a)(1)(iii)	Quantity of Hopping Channel	Compliant
§15.247(a)(1)(iii)	Time of Occupancy(Dwell Time)	Compliant
§15.247(b)	Max Peak output Power test	Compliant
§15.247(d)	Band edge test	Compliant
§15.203	Antenna Requirement	Compliant

4. Description of test modes

The EUT has been tested under its typical operating condition and fully-charged battery for EUT tested alone. Pre-defined engineering program for regulatory testing used to control the EUT for staying in continuous transmitting. Only the worst case data were reported.

The EUT has been associated with peripherals pursuant to ANSI C63.10-2013 and configuration operated in a manner tended to maximize its emission characteristics in a typical application. Frequency range investigated: radiation (9 KHz to the 10th harmonics of the highest fundamental frequency or to 40 GHz, whichever is lower).

The EUT has been tested under TX operating condition.

Pre-defined engineering program for regulatory testing used to control the EUT for staying in continuous transmitting mode is programmed. EUT is connected by com port, and transmit the control instruction via test software(FCC_assist 1.0.1.1). The test software power value is set to the maximum.

This EUT is a FHSS system, were conducted to determine the final configuration from all possible combinations. We use software control the EUT, Let EUT hopping on and transmit with highest power, all the modes GFSK, $\pi/4$ -DQPSK, 8DPSK have been tested. 79 Channels are provided by EUT. The 3 channels of lower, medium and higher were chosen for test.

Channel	Frequency(MHz)
1	2402
40	2441
79	2480

5. TEST SYSTEM UNCERTAINTY

The following measurement uncertainty levels have been estimated for tests performed on the apparatus:

Parameter	Uncertainty
Radio Frequency	$\pm 1 \times 10^{-5}$
Maximum Peak Output Power Test	$\pm 1.0\text{dB}$
Conducted Emissions Test(150KHz-30MHz)	$\pm 2.0\text{dB}$
Radiated Emission Test (30MHz-1000MHz)	$\pm 2.0\text{dB}$
Radiated Emission Test (1GHz-18GHz)	$\pm 2.5\text{dB}$
Radiated Emission Test (18GHz-25GHz)	$\pm 3.2\text{dB}$
Power Density	$\pm 2.0\text{dB}$
Occupied Bandwidth Test	$\pm 1.0\text{dB}$
Band Edge Test	$\pm 3\text{dB}$
All emission, radiated	$\pm 3\text{dB}$
Antenna Port Emission	$\pm 3\text{dB}$
Temperature	$\pm 0.5^{\circ}\text{C}$
Humidity	$\pm 3\%$

Remark: The coverage Factor (k=2), and measurement Uncertainty for a level of Confidence of 95%

6. Conducted Emissions Test

6.1 Measurement Procedure:

1. The EUT was placed on a table, which is 0.8m above ground plane.
2. Maximum procedure was performed on the six highest emissions to ensure EUT compliance.
3. Repeat above procedures until all frequency measured was complete.

6.2 Test SET-UP (Block Diagram of Configuration)

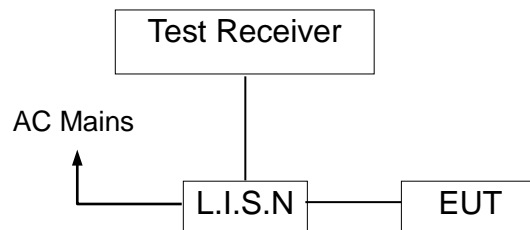

6.3 Measurement Equipment Used:

Equipment	Manufacturer	Model No.	Serial No.	Last Cal.	Due Date
Shielded Room	CHENG YU	8m*5m*4m	N/A	2022/10/29	2025/10/28
EMI Test Receiver	Rohde & Schwarz	ESR3	102647	2022/12/03	2023/12/02
LISN/AMN	Rohde & Schwarz	ENV216	102843	2023/09/18	2024/09/17
NNLK 8129 RC	Schwarzbeck	NNLK 8129 RC	5046	2023/03/30	2024/03/29
Test Software	Farad	EZ-EMC (Ver. EMC-con-3A1 1+)	N/A	N/A	N/A

6.4 Measurement Result:

Operation Mode: TX Test Date : Sep. 26, 2023
 Frequency Range: 0.15MHz~30MHz Temperature : 23.5℃
 Test Result: PASS Humidity : 52.6 %
 Test By: Zero

All the modulation modes were tested the data of the worst mode (Pi/4-DQPSK TX 2402MHz) are recorded in the following pages and the others modulation methods do not exceed the limits.

Please refer to the following data.

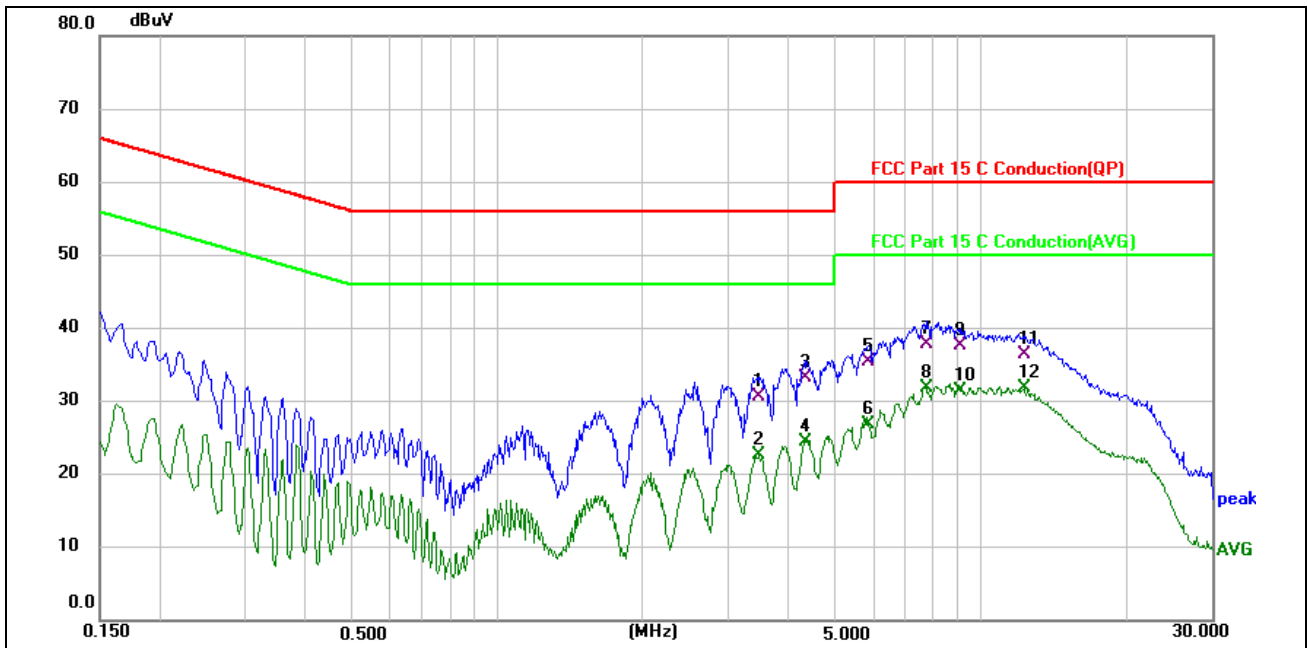

Site:	843	Phase: L1	Temperature(C): 23.5(C)
Limit:	FCC Part 15 C Conduction(QP)	Test Time:	Humidity(%): 52.6%
EUT:	A4 Thermal Printer	Power Rating:	5Vdc from AC/DC adapter
M/N.:	L81	Test Engineer:	Zero
Mode:	TX2402		
Note:			

No.	Frequency (MHz)	Reading Level(dBuV)	Factor (dB)	Measurement(dBuV)	Limit (dBuV)	Margin (dB)	Detector	Comment
1	3.4820	20.15	10.45	30.60	56.00	-25.40	QP	
2	3.4820	12.18	10.45	22.63	46.00	-23.37	AVG	
3	4.3340	22.73	10.47	33.20	56.00	-22.80	QP	
4	4.3340	13.96	10.47	24.43	46.00	-21.57	AVG	
5	5.8500	24.99	10.51	35.50	60.00	-24.50	QP	
6	5.8500	16.24	10.51	26.75	50.00	-23.25	AVG	
7	7.7060	27.29	10.61	37.90	60.00	-22.10	QP	
8	7.7060	21.18	10.61	31.79	50.00	-18.21	AVG	
9	9.0900	27.03	10.67	37.70	60.00	-22.30	QP	
10	9.0900	20.85	10.67	31.52	50.00	-18.48	AVG	
11	12.2540	25.71	10.79	36.50	60.00	-23.50	QP	
12	12.2540	21.06	10.79	31.85	50.00	-18.15	AVG	

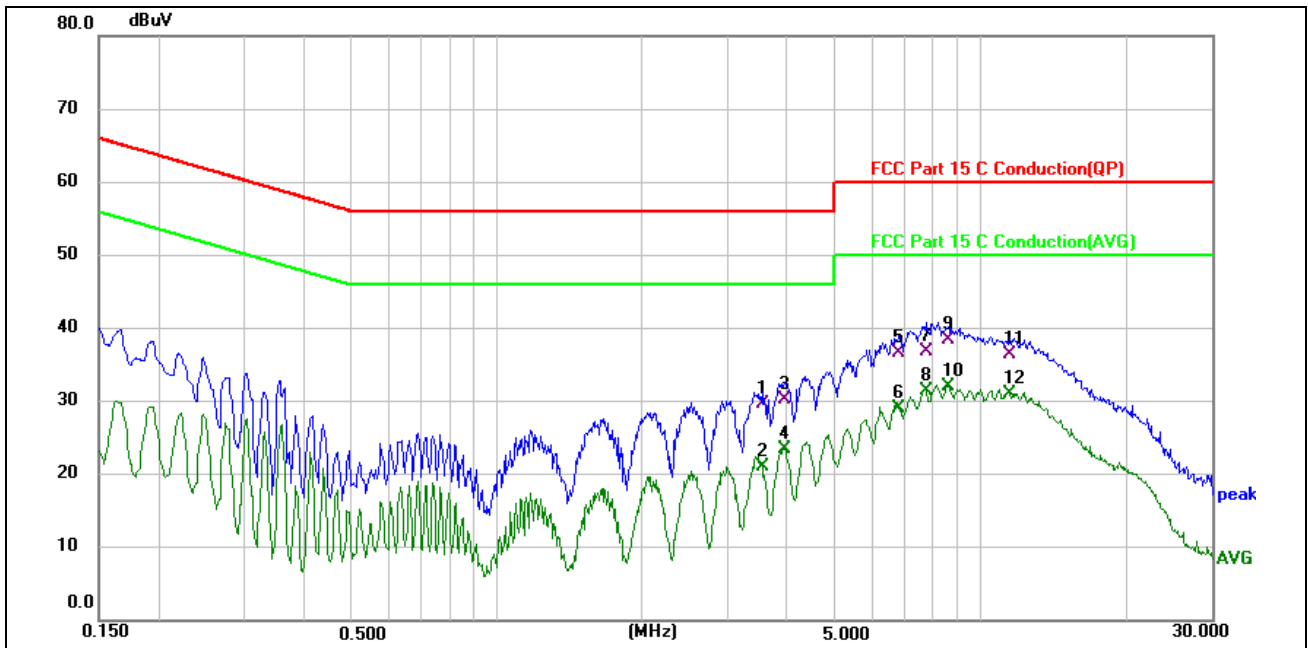

Site:	843	Phase:	N	Temperature(C):	23.5(C)
Limit:	FCC Part 15 C Conduction(QP)	Test Time:	2023-09-26	Humidity(%):	52.6%
EUT:	A4 Thermal Printer	Power Rating:	5Vdc from AC/DC adapter	Note:	
M/N.:	L81	Test Engineer:	Zero		
Mode:	TX2402				

No.	Frequency (MHz)	Reading Level(dBuV)	Factor (dB)	Measurement(dBuV)	Limit (dBuV)	Margin (dB)	Detector	Comment
1	3.5380	19.22	10.38	29.60	56.00	-26.40	QP	
2	3.5380	10.57	10.38	20.95	46.00	-25.05	AVG	
3	3.9260	19.81	10.39	30.20	56.00	-25.80	QP	
4	3.9260	12.99	10.39	23.38	46.00	-22.62	AVG	
5	6.7820	26.11	10.49	36.60	60.00	-23.40	QP	
6	6.7820	18.63	10.49	29.12	50.00	-20.88	AVG	
7	7.6900	26.37	10.53	36.90	60.00	-23.10	QP	
8	7.6900	20.93	10.53	31.46	50.00	-18.54	AVG	
9	8.5740	27.83	10.57	38.40	60.00	-21.60	QP	
10	8.5740	21.44	10.57	32.01	50.00	-17.99	AVG	
11	11.4740	25.83	10.67	36.50	60.00	-23.50	QP	
12	11.4740	20.43	10.67	31.10	50.00	-18.90	AVG	

6.5 Conducted Measurement Photos:



7. Radiated Emission Test

7.1 Measurement Procedure

1. The testing follows the guidelines in Spurious Radiated Emissions of ANSI C63.10-2013.
2. Below 1000MHz, The EUT was placed on a turn table which is 0.8m above ground plane. And above 1000MHz, The EUT was placed on a styrofoam table which is 1.5m above ground plane.
3. The EUT was set 3 meters from the interference receiving antenna, which was mounted on the top of a variable height antenna tower.
4. For each suspected emission, the EUT was arranged to its worst case and then tune the Antenna tower (From 1m to 4m) and turntable (from 0 degree to 360 degree) to find the maximum reading. A pre-amp and a high pass filter are used for the test in order to get better signal level to comply with the guidelines.
5. Set to the maximum power setting and enable the EUT transmit continuously.
6. Final measurement (Above 1GHz): The frequency range will be divided into different sub ranges depending of the frequency range of the used horn antenna. The EMI Receiver set to peak and average mode and a resolution bandwidth of 1MHz. The measurement will be performed in horizontal and vertical polarization of the measuring antenna and while rotating the EUT in its vertical axis in the range of 0 degree to 360 degree in order to have the antenna inside the cone of radiation.
7. Test Procedure of measurement (For Above 1GHz):
 - 1) Monitor the frequency range at horizontal polarization and move the antenna over all sides of the EUT(if necessary move the EUT to another orthogonal axis).
 - 2) Change the antenna polarization and repeat 1) with vertical polarization.
 - 3) Make a hardcopy of the spectrum.
 - 4) Measure the frequency of the detected emissions with a lower span and resolution bandwidth to increase the accuracy and note the frequency value.
 - 5) Change the analyser mode to Clear/ Write and found the cone of emission.
 - 6) Rotate and move the EUT, so that the measuring distance can be enlarged to 3m and the antenna will be still inside the cone of emission.
 - 7) Measure the level of the detected frequency with the correct resolution bandwidth, with the antenna polarization and azimuth and the peak and average detector, which causes the maximum emission.
 - 8) Repeat steps 1) to 7) for the next antenna spot if the EUT is larger than the antenna beamwidth.

Use the following spectrum analyzer settings:

When spectrum scanned from 30MHz to 1GHz setting resolution bandwidth 120KHz

and video bandwidth 300KHz:

EMI Test Receiver	Setting
Attenuation	Auto
RB	120KHz
VB	300KHz
Detector	QP
Trace	Max hold

When spectrum scanned above 1GHz setting resolution bandwidth 1MHz, video bandwidth 3MHz:

EMI Test Receiver	Setting
Attenuation	Auto
RB	1MHz
VB	3MHz
Detector	Peak
Trace	Max hold

When spectrum scanned above 1GHz setting resolution bandwidth 1MHz, video bandwidth 10Hz:

EMI Test Receiver	Setting
Attenuation	Auto
RB	1MHz
VB	10Hz
Detector	Average
Trace	Max hold

7.2 Test SET-UP (Block Diagram of Configuration)

(A) Radiated Emission Test Set-Up, Frequency Below 30MHz

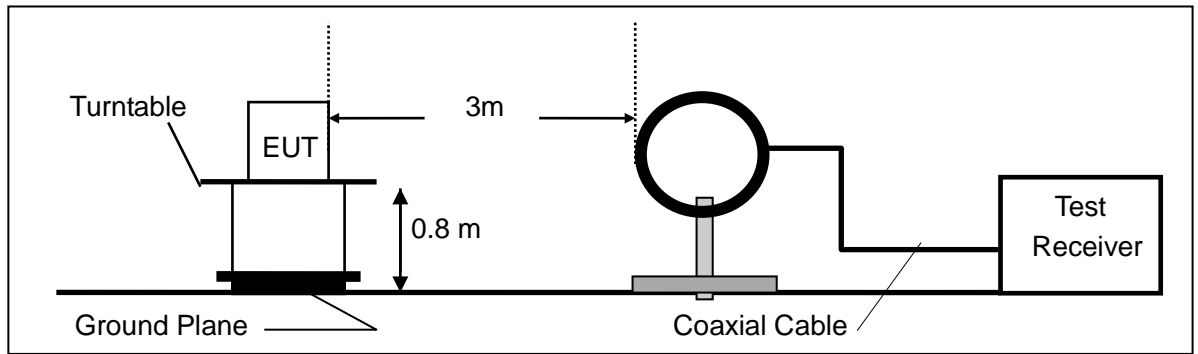

(B) Radiated Emission Test Set-Up, Frequency Below 1000MHz

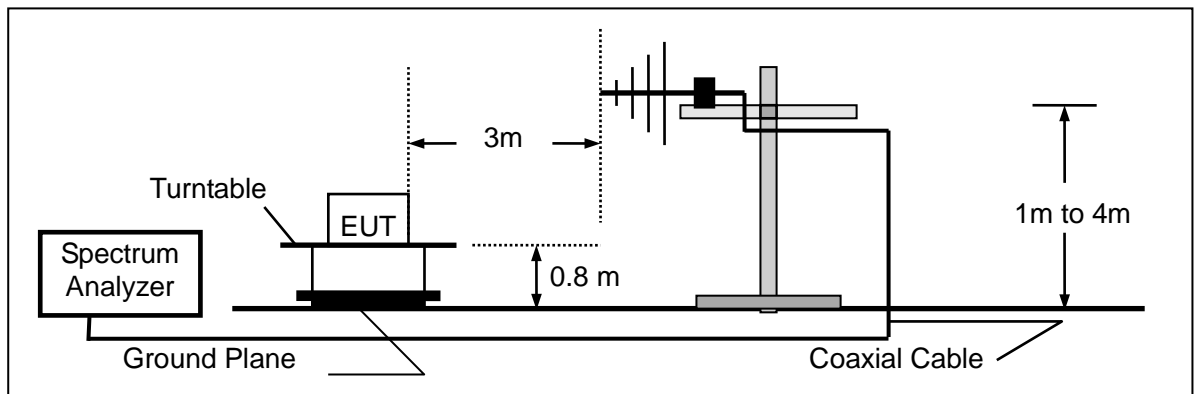

(C) Radiated Emission Test Set-Up, Frequency above 1000MHz

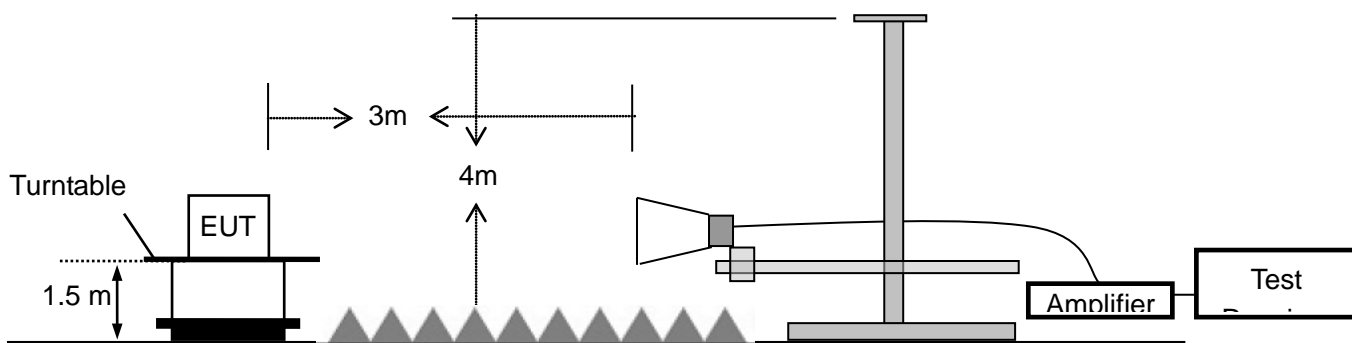

7.3 Measurement Equipment Used:

Test Equipment of Radiated emissions below 1GHz					
Equipment	Manufacturer	Model No.	Serial No.	Last Cal.	Due Date
3m Semi-anechoic Chamber	ETS	9m*6m*6m	Q2146	2022/08/30	2025/08/29
EMI Test Receiver	Rohde & Schwarz	ESCI3	101409	2023/09/18	2024/09/17
Pre-Amplifier	HzEMC	HPA-9K0130	HYP A21001	2022/10/29	2023/10/28
Biconilog Antenna	Schwarzbeck	VULB 9168	01315	2022/10/10	2025/10/09
Biconilog Antenna	ETS	3142E	00243646	2022/03/23	2025/03/22
Loop Antenna	ETS	6502	243668	2022/03/30	2025/03/29
Test Software	Farad	EZ-EMC (Ver.FA-03A2 RE)	N/A	N/A	N/A

Test Equipment of Radiated emissions above 1GHz					
Equipment	Manufacturer	Model No.	Serial No.	Last Cal.	Due Date
3m Semi-anechoic Chamber	ETS	9m*6m*6m	Q2149	2022/08/30	2025/08/29
Spectrum Analyzer	Rohde & Schwarz	FSV40	101413	2023/09/18	2024/09/17
Pre-Amplifier	A-INFO	HPA-1G1850	HYP A21003	2022/10/29	2023/10/28
Horn antenna	A-INFO	3117	246069	2022/03/11	2024/03/10
Pre-Amplifier	ZKJC	HPA-184057	HYP A21004	2022/10/29	2023/10/28
Horn antenna	ZKJC	3116C	246265	2023/03/29	2024/03/28
Test Software	Farad	EZ-EMC (Ver.FA-03A2 RE+)	N/A	N/A	N/A

7..4 Radiated Emission Limit

The emissions from an intentional radiator shall not exceed the field strength levels specified in the following table 15.209(a):

Frequencies (MHz)	Field Strength (micorvolts/meter)	Measurement Distance (meters)
0.009~0.490	2400/F(KHz)	300
0.490~1.705	24000/F(KHz)	30
1.705~30.0	30	30
30~88	100	3
88~216	150	3
216~960	200	3
Above 960	500	3

15.205 Restricted bands of operation

MHz	MHz	MHz	GHz
0.090 - 0.110	16.42 - 16.423	399.9 - 410	4.5 - 5.15
¹ 0.495 - 0.505	16.69475 - 16.69525	608 - 614	5.35 - 5.46
2.1735 - 2.1905	16.80425 - 16.80475	960 - 1240	7.25 - 7.75
4.125 - 4.128	25.5 - 25.67	1300 - 1427	8.025 - 8.5
4.17725 - 4.17775	37.5 - 38.25	1435 - 1626.5	9.0 - 9.2
4.20725 - 4.20775	73 - 74.6	1645.5 - 1646.5	9.3 - 9.5
6.215 - 6.218	74.8 - 75.2	1660 - 1710	10.6 - 12.7
6.26775 - 6.26825	108 - 121.94	1718.8 - 1722.2	13.25 - 13.4
6.31175 - 6.31225	123 - 138	2200 - 2300	14.47 - 14.5
8.291 - 8.294	149.9 - 150.05	2310 - 2390	15.35 - 16.2
8.362 - 8.366	156.52475 - 156.52525	2483.5 - 2500	17.7 - 21.4
8.37625 - 8.38675	156.7 - 156.9	2690 - 2900	22.01 - 23.12
8.41425 - 8.41475	162.0125 - 167.17	3260 - 3267	23.6 - 24.0
12.29 - 12.293	167.72 - 173.2	3332 - 3339	31.2 - 31.8
12.51975 - 12.52025	240 - 285	3345.8 - 3358	36.43 - 36.5
12.57675 - 12.57725	322 - 335.4	3600 - 4400	(²)

Remark 1. Emission level in dBuV/m=20 log (uV/m)

- :
- Measurement was performed at an antenna to the closed point of EUT distance of meters.
 - Only spurious frequency is permitted to locate within the Restricted Bands specified in provision of ξ 15.205, and the emissions located in restricted bands also comply with 15.209 limit.

7.5 Measurement Result

Operation Mode:	TX	Test Date :	Sep. 26, 2023
Test By:	Zero	Temperature :	24.8°C
Test Result:	PASS	Humidity :	51.7%
Measured Distance:	3m		

Below 30MHz:

Freq. (MHz)	Ant.Pol. H/V	Emission Level (dBuV/m)	Limit 3m (dBuV/m)	Over (dB)
--	--	--	--	--

Note: The low frequency, which started from 9KHz-30MHz, was pre-scanned and the result which was 20dB lower than the limit line per 15.31(o) was not reported.

Below 1000MHz:

Pass.

All the modulation modes were tested the data of the worst mode ((Pi/4-DQPSK TX 2402MHz)) are recorded in the following pages and the others modulation methods do not exceed the limits.

Please refer to the following data.

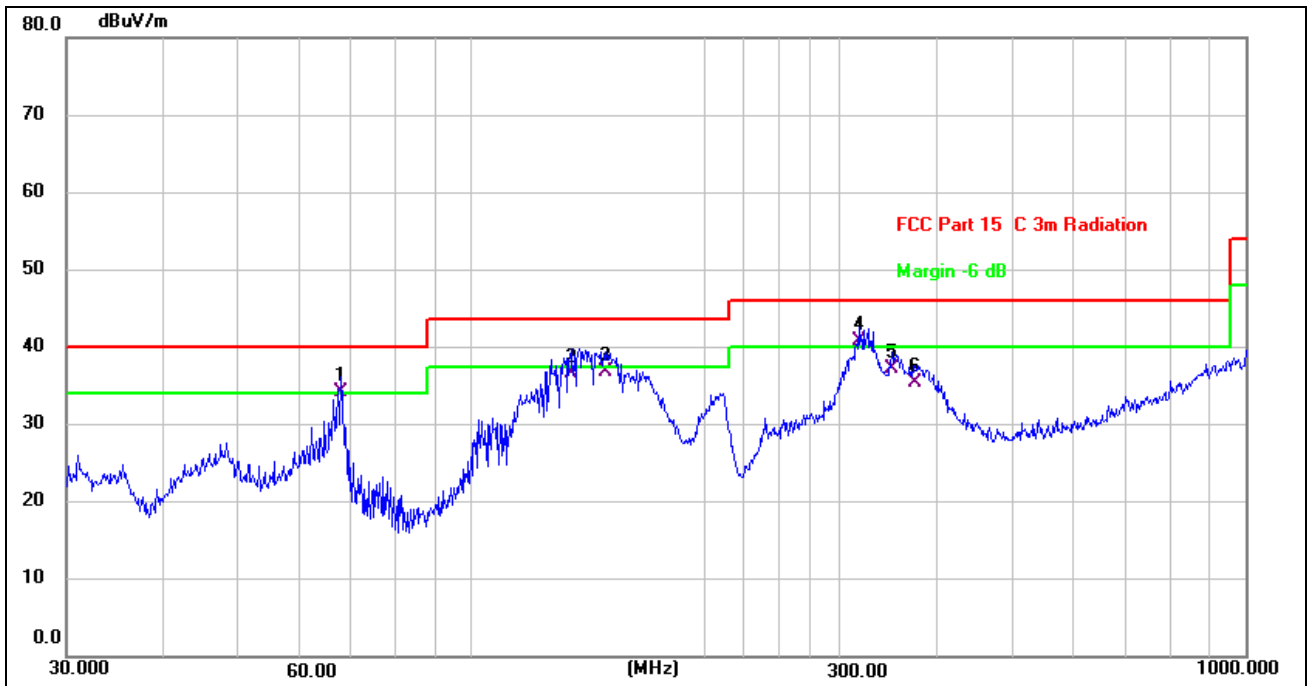

Site:	LAB	Antenna::	Vertical	Temperature(C):	24.8(C)
Limit:	FCC Part 15 C 3m Radiation(QP)	Test Time:	2023-09-26	Humidity(%):	51.7%
EUT:	A4 Thermal Printer	Power Rating:	Battery DC 7.2V	Mode:	TX2402
M/N.:	L81	Test Engineer:	Zero	Note:	

No.	Frequency (MHz)	Reading (dBuV)	Factor (dB/m)	Level (dBuV/m)	Limit (dBuV/m)	Margin (dB)	Det.	Remark
1	67.9129	42.10	-7.90	34.20	40.00	-5.80	QP	
2	134.5592	44.57	-7.97	36.60	43.50	-6.90	QP	
3	148.9625	47.17	-10.27	36.90	43.50	-6.60	QP	
4	316.5890	42.43	-1.63	40.80	46.00	-5.20	QP	
5	349.2500	37.89	-0.69	37.20	46.00	-8.80	QP	
6	374.6225	35.47	0.03	35.50	46.00	-10.50	QP	

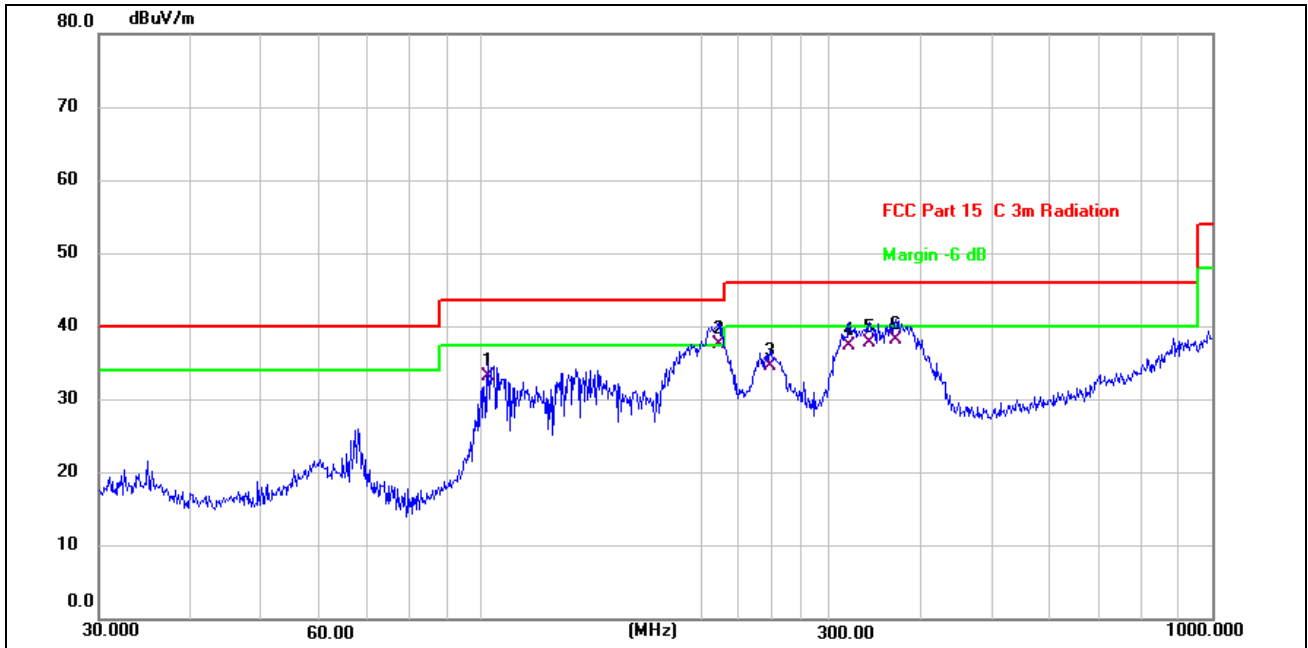

Site:	LAB	Antenna::	Horizontal	Temperature(C):	24.8(C)
Limit:	FCC Part 15C 3m Radiation(QP)	Test Time:		Humidity(%):	51.7%
EUT:	A4 Thermal Printer	Power Rating:		Battery DC	7.2V
M/N.:	L81	Test Engineer:		Zero	
Mode:	TX2402				
Note:					

No.	Frequency (MHz)	Reading (dBuV)	Factor (dB/m)	Level (dBuV/m)	Limit (dBuV/m)	Margin (dB)	Det.	Remark
1	102.3597	38.00	-4.80	33.20	43.50	-10.30	QP	
2	211.5265	42.58	-4.88	37.70	43.50	-5.80	QP	
3	248.5519	38.48	-3.88	34.60	46.00	-11.40	QP	
4	318.8170	39.09	-1.59	37.50	46.00	-8.50	QP	
5	339.5888	38.81	-1.01	37.80	46.00	-8.20	QP	
6	369.4047	38.32	-0.12	38.20	46.00	-7.80	QP	

Above 1000MHz~10th Harmonics:

Please refer to the following data.

Operation Mode: GFSK (CH1: 2402MHz) Test Date : 2023-09-26

Freq. (MHz)	Ant. Pol.	Reading Level(dBuV/m)		Correct Factor dB	Emission Level(dBuV/m)		Limit 3m(dBuV/m)		Margin(dB)	
		PK	AV		PK	AV	PK	AV	PK	AV
4804	V	94.61	75.32	-32.3	62.31	43.02	74	54	-11.69	-10.98
7206	V	98.44	78.81	-37.25	61.19	41.56	74	54	-12.81	-12.44
9608	V	100.35	80.67	-39.8	60.55	40.87	74	54	-13.45	-13.13
12010	V	97.68	79.11	-40.5	57.18	38.61	74	54	-16.82	-15.39
14412	V	98.06	79.27	-41.7	56.36	37.57	74	54	-17.64	-16.43
16814	V	95.37	76.52	-40	55.37	36.52	74	54	-18.63	-17.48
4804	H	93.46	74.92	-31.4	62.06	43.52	74	54	-11.94	-10.48
7206	H	96.61	77.82	-35.5	61.11	42.32	74	54	-12.89	-11.68
9608	H	98.87	79.51	-38.3	60.57	41.21	74	54	-13.43	-12.79
12010	H	96.58	77.27	-39	57.58	38.27	74	54	-16.42	-15.73
14412	H	98.31	78.45	-42	56.31	36.45	74	54	-17.69	-17.55
16814	H	94.78	75.66	-39.3	55.48	36.36	74	54	-18.52	-17.64

Operation Mode: GFSK (CH40: 2441MHz) Test Date : 2023-09-26

Freq. (MHz)	Ant. Pol.	Reading Level(dBuV/m)		Correct Factor dB	Emission Level(dBuV/m)		Limit 3m(dBuV/m)		Margin(dB)	
		PK	AV		PK	AV	PK	AV	PK	AV
4882	V	94.64	75.56	-32.3	62.34	43.26	74	54	-11.66	-10.74
7323	V	97.54	78.33	-37.2	60.34	41.13	74	54	-13.66	-12.87
9764	V	98.24	79.05	-39.6	58.64	39.45	74	54	-15.36	-14.55
12205	V	97.75	79.14	-40.5	57.25	38.64	74	54	-16.75	-15.36
14646	V	97.31	78.8	-41	56.31	37.8	74	54	-17.69	-16.2
17087	V	96.13	77.21	-41.1	55.03	36.11	74	54	-18.97	-17.89
4882	H	93.74	74.35	-31.6	62.14	42.75	74	54	-11.86	-11.25
7323	H	95.99	76.97	-35.7	60.29	41.27	74	54	-13.71	-12.73
9764	H	96.57	77.93	-38.3	58.27	39.63	74	54	-15.73	-14.37
12205	H	96.31	77.16	-39	57.31	38.16	74	54	-16.69	-15.84
14646	H	98.34	79.82	-42	56.34	37.82	74	54	-17.66	-16.18
17087	H	96.98	77.95	-41.5	55.48	36.45	74	54	-18.52	-17.55

Operation Mode: GFSK (CH79: 2480MHz) Test Date : 2023-09-26

Freq. (MHz)	Ant. Pol. H/V	Reading Level(dBuV/m)		Correct Factor dB	Emission Level(dBuV/m)		Limit 3m(dBuV/m)		Margin(dB)	
		PK	AV		PK	AV	PK	AV	PK	AV
4960	V	94.58	75.86	-32.3	62.28	43.56	74	54	-11.72	-10.44
7440	V	97.51	78.77	-37.2	60.31	41.57	74	54	-13.69	-12.43
9920	V	99.24	79.93	-39.6	59.64	40.33	74	54	-14.36	-13.67
12400	V	98.04	79.37	-40.7	57.34	38.67	74	54	-16.66	-15.33
14880	V	97.46	78.84	-41	56.46	37.84	74	54	-17.54	-16.16
17360	V	96.42	77.69	-41.1	55.32	36.59	74	54	-18.68	-17.41
4960	H	92.74	74.28	-31.6	61.14	42.68	74	54	-12.86	-11.32
7440	H	96.01	77.26	-35.7	60.31	41.56	74	54	-13.69	-12.44
9920	H	97.47	78.43	-38.1	59.37	40.33	74	54	-14.63	-13.67
12400	H	96.11	77.68	-39	57.11	38.68	74	54	-16.89	-15.32
14880	H	98.33	79.86	-42	56.33	37.86	74	54	-17.67	-16.14
17360	H	96.95	78.07	-41.5	55.45	36.57	74	54	-18.55	-17.43

Operation Mode: Pi/4-DQPSK (CH1: 2402MHz) Test Date : 2023-09-26

Freq. (MHz)	Ant. Pol. H/V	Reading Level(dBuV/m)		Correct Factor dB	Emission Level(dBuV/m)		Limit 3m(dBuV/m)		Margin(dB)	
		PK	AV		PK	AV	PK	AV	PK	AV
4960	V	94.59	75.86	-32.3	62.29	43.56	74	54	-11.71	-10.44
7440	V	97.53	78.77	-37.2	60.33	41.57	74	54	-13.67	-12.43
9920	V	99.24	79.91	-39.6	59.64	40.31	74	54	-14.36	-13.69
12400	V	98.06	79.37	-40.7	57.36	38.67	74	54	-16.64	-15.33
14880	V	97.45	78.84	-41	56.45	37.84	74	54	-17.55	-16.16
17360	V	96.42	77.69	-41.1	55.32	36.59	74	54	-18.68	-17.41
4960	H	92.78	74.28	-31.6	61.18	42.68	74	54	-12.82	-11.32
7440	H	96.04	77.27	-35.7	60.34	41.57	74	54	-13.66	-12.43
9920	H	97.45	78.43	-38.1	59.35	40.33	74	54	-14.65	-13.67
12400	H	96.14	77.67	-39	57.14	38.67	74	54	-16.86	-15.33
14880	H	98.33	79.84	-42	56.33	37.84	74	54	-17.67	-16.16
17360	H	96.98	78.07	-41.5	55.48	36.57	74	54	-18.52	-17.43

Operation Mode: Pi/4-DQPSK (CH40: 2441MHz) Test Date : 2023-09-26

Freq. (MHz)	Ant. Pol. H/V	Reading Level(dBuV/m)		Correct Factor dB	Emission Level(dBuV/m)		Limit 3m(dBuV/m)		Over(dB)	
		PK	AV		PK	AV	PK	AV	PK	AV
4882	V	95.52	75.52	-32.3	63.22	43.22	74	54	-10.78	-10.78
7323	V	98.32	79.33	-37.2	61.12	42.13	74	54	-12.88	-11.87
9764	V	99.42	80.54	-39.8	59.62	40.74	74	54	-14.38	-13.26
12205	V	98.96	80.07	-40.5	58.46	39.57	74	54	-15.54	-14.43
14646	V	98.54	79.31	-41	57.54	38.31	74	54	-16.46	-15.69
17087	V	96.32	77.58	-41.1	55.22	36.48	74	54	-18.78	-17.52
4882	H	94.69	75.16	-31.6	63.09	43.56	74	54	-10.91	-10.44
7323	H	96.53	77.84	-35.5	61.03	42.34	74	54	-12.97	-11.66
9764	H	97.76	78.64	-38.3	59.46	40.34	74	54	-14.54	-13.66
12205	H	97.61	78.57	-39	58.61	39.57	74	54	-15.39	-14.43
14646	H	98.33	79.54	-42	56.33	37.54	74	54	-17.67	-16.46
17087	H	96.57	77.99	-41.4	55.17	36.59	74	54	-18.83	-17.41

Operation Mode: Pi/4-DQPSK (CH79: 2480MHz) Test Date : 2023-09-26

Freq. (MHz)	Ant. Pol. H/V	Reading Level(dBuV/m)		Correct Factor dB	Emission Level(dBuV/m)		Limit 3m(dBuV/m)		Over(dB)	
		PK	AV		PK	AV	PK	AV	PK	AV
4960	V	94.65	75.94	-32.3	62.35	43.64	74	54	-11.65	-10.36
7440	V	97.54	78.57	-37.2	60.34	41.37	74	54	-13.66	-12.63
9920	V	99.45	80.11	-39.8	59.65	40.31	74	54	-14.35	-13.69
12400	V	98.84	80.15	-40.5	58.34	39.65	74	54	-15.66	-14.35
14880	V	97.27	78.84	-41	56.27	37.84	74	54	-17.73	-16.16
17360	V	96.56	77.99	-41.1	55.46	36.89	74	54	-18.54	-17.11
4960	H	93.99	75.17	-31.6	62.39	43.57	74	54	-11.61	-10.43
7440	H	95.11	76.02	-35.5	59.61	40.52	74	54	-14.39	-13.48
9920	H	96.94	78.11	-38.3	58.64	39.81	74	54	-15.36	-14.19
12400	H	95.34	76.66	-39	56.34	37.66	74	54	-17.66	-16.34
14880	H	97.59	78.46	-42	55.59	36.46	74	54	-18.41	-17.54
17360	H	96.84	78.11	-41.5	55.34	36.61	74	54	-18.66	-17.39

Operation Mode: 8DPSK (CH1: 2402MHz) Test Date : 2023-09-26

Freq.	Ant. Pol.	Reading Level(dBuV/m)		Correct Factor	Emission Level(dBuV/m)		Limit 3m(dBuV/m)		Over(dB)	
		PK	AV		PK	AV	PK	AV	PK	AV
(MHz)	H/V			dB						
4804	V	96.08	76.53	-32.3	63.78	44.23	74	54	-10.22	-9.77
7206	V	98.94	80.09	-37.2	61.74	42.89	74	54	-12.26	-11.1
9608	V	100.12	81.03	-39.8	60.32	41.23	74	54	-13.68	-12.8
12010	V	99.13	80.08	-40.5	58.63	39.58	74	54	-15.37	-14.4
14412	V	99.33	80.3	-41.7	57.63	38.6	74	54	-16.37	-15.4
16814	V	96.02	77.85	-40	56.02	37.85	74	54	-17.98	-16.2
4804	H	93.75	74.82	-31.6	62.15	43.22	74	54	-11.85	-10.8
7206	H	97.63	77.86	-35.5	62.13	42.36	74	54	-11.87	-11.6
9608	H	98.43	79.53	-38.3	60.13	41.23	74	54	-13.87	-12.8
12010	H	97.34	78.62	-39	58.34	39.62	74	54	-15.66	-14.4
14412	H	99.42	80.63	-42	57.42	38.63	74	54	-16.58	-15.4
16814	H	94.66	75.88	-39.3	55.36	36.58	74	54	-18.64	-17.4

Operation Mode: 8DPSK (CH40: 2441MHz) Test Date : 2023-09-26

Freq.	Ant. Pol.	Reading Level(dBuV/m)		Correct Factor	Emission Level(dBuV/m)		Limit 3m(dBuV/m)		Over(dB)	
		PK	AV		PK	AV	PK	AV	PK	AV
(MHz)	H/V			dB						
4882	V	95.45	76.19	-32.3	63.15	43.89	74	54	-10.85	-10.11
7323	V	98.54	79.56	-37.2	61.34	42.36	74	54	-12.66	-11.64
9764	V	99.04	79.86	-39.8	59.24	40.06	74	54	-14.76	-13.94
12205	V	98.06	79.04	-40.5	57.56	38.54	74	54	-16.44	-15.46
14646	V	97.32	78.58	-41	56.32	37.58	74	54	-17.68	-16.42
17087	V	96.55	77.46	-41.1	55.45	36.36	74	54	-18.55	-17.64
4882	H	94.69	76.21	-31.6	63.09	44.61	74	54	-10.91	-9.39
7323	H	96.72	77.85	-35.5	61.22	42.35	74	54	-12.78	-11.65
9764	H	97.65	78.61	-38.3	59.35	40.31	74	54	-14.65	-13.69
12205	H	96.14	77.68	-39	57.14	38.68	74	54	-16.86	-15.32
14646	H	98.31	79.84	-42	56.31	37.84	74	54	-17.69	-16.16
17087	H	96.63	77.74	-41.5	55.13	36.24	74	54	-18.87	-17.76

Operation Mode: 8DPSK (CH79: 2480MHz) Test Date : 2023-09-26

Freq.	Ant. Pol.	Reading Level(dBuV/m)		Correct Factor	Emission Level(dBuV/m)		Limit 3m(dBuV/m)		Over(dB)	
		PK	AV		PK	AV	PK	AV	PK	AV
(MHz)	H/V			dB						
4960	V	94.99	75.99	-32.3	62.69	43.69	74	54	-11.31	-10.31
7440	V	97.45	78.72	-37.2	60.25	41.52	74	54	-13.75	-12.48
9920	V	99.16	79.93	-39.8	59.36	40.13	74	54	-14.64	-13.87
12400	V	98.04	79	-40.5	57.54	38.5	74	54	-16.46	-15.5
14880	V	97.58	78.58	-41	56.58	37.58	74	54	-17.42	-16.42
17360	V	96.42	77.45	-41.1	55.32	36.35	74	54	-18.68	-17.65
4960	H	93.91	74.7	-31.6	62.31	43.1	74	54	-11.69	-10.9
7440	H	95.86	77.19	-35.5	60.36	41.69	74	54	-13.64	-12.31
9920	H	97.47	78.55	-38.3	59.17	40.25	74	54	-14.83	-13.75
12400	H	96.68	77.11	-39	57.68	38.11	74	54	-16.32	-15.89
14880	H	98.58	79.85	-42	56.58	37.85	74	54	-17.42	-16.15
17360	H	96.97	77.97	-41.5	55.47	36.47	74	54	-18.53	-17.53

Other harmonics emissions are lower than 20dB below the allowable limit.

- Note:**
- (1) All Readings are Peak Value and AV.
 - (2) Emission Level= Reading Level+ Probe Factor +Cable Loss.
 - (3) The average measurement was not performed when the peak measured data under the limit of average detection.
 - (4) Measuring frequencies from 1GHz to 25GHz.

7.5 Radiated Measurement Photos:



8. Channel Separation test

8.1 Measurement Procedure

The EUT was operating in hopping mode or could be controlled its channel. Printed out the test result from the spectrum by hard copy function.

8.2 Test SET-UP (Block Diagram of Configuration)

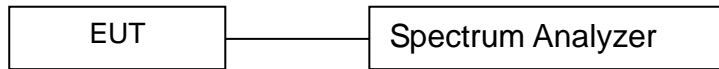

8.3 Measurement Equipment Used:

Test Equipment of Conducted RF					
Equipment	Manufacturer	Model No.	Serial No.	Last Cal.	Due Date
Spectrum Analyzer	Rohde & Schwarz	FSV40	102257	2023/09/18	2024/09/17
EXG Analog Signal Generator	KEYSIGHT	N5173B	MY61253075	2023/09/18	2024/09/17
Vector Signal Generator	Rohde & Schwarz	SMM100A	101899	2023/03/16	2024/03/15
RF Control box	MWRF-test	MW100-RFCB	MW220926GTG	2023/09/18	2024/09/17
Wideband Radio Communication Tester	Rohde & Schwarz	CMW270	102792	2023/03/16	2024/03/15
Wideband Radio Communication Tester	Rohde & Schwarz	CMW500	103235	2023/09/18	2024/09/17
temperature humidity chamber	Espec	SH-241	SH-241-2014	2023/09/18	2024/09/17
RF Test Software	MWRF-test	MTS8310E (Ver. V2/0)	N/A	N/A	N/A

8.4 Measurement Results:

Refer to attached data chart.

Spectrum Detector: PK Test Date : Sep. 18, 2023
 Test By: Zero Temperature : 24°C
 Test Result: PASS Humidity : 53 %
 Modulation: GFSK, $\pi/4$ -DQPSK, 8DPSK

Condition	Mode	Antenna	Hopping Freq1 (MHz)	Hopping Freq2 (MHz)	HFS (MHz)	Limit (MHz)	Verdict
NVNT	1-DH5	Ant1	2401.99	2402.996	1.006	0.617	Pass
NVNT	1-DH5	Ant1	2440.988	2442.072	1.084	0.633	Pass
NVNT	1-DH5	Ant1	2478.988	2480.022	1.034	0.639	Pass
NVNT	2-DH5	Ant1	2402.116	2403.022	0.906	0.837	Pass
NVNT	2-DH5	Ant1	2440.9	2441.844	0.944	0.799	Pass
NVNT	2-DH5	Ant1	2479.042	2480.02	0.978	0.821	Pass
NVNT	3-DH5	Ant1	2401.904	2402.832	0.928	0.861	Pass
NVNT	3-DH5	Ant1	2441.054	2442.058	1.004	0.8	Pass
NVNT	3-DH5	Ant1	2479.048	2480.01	0.962	0.826	Pass

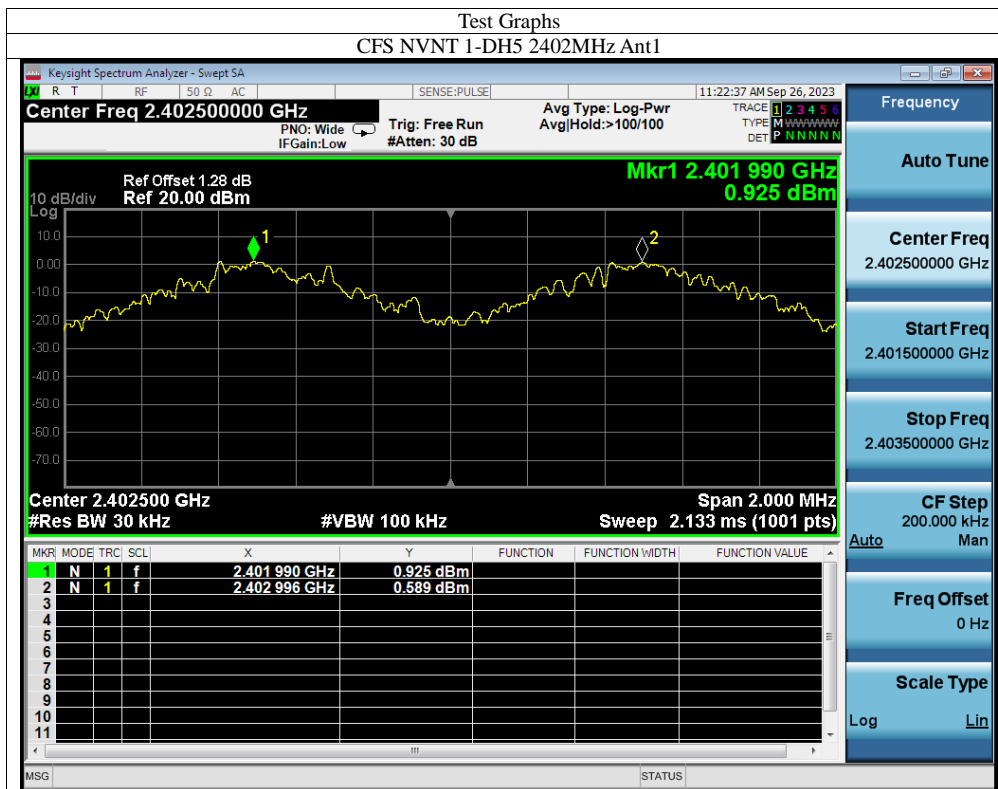

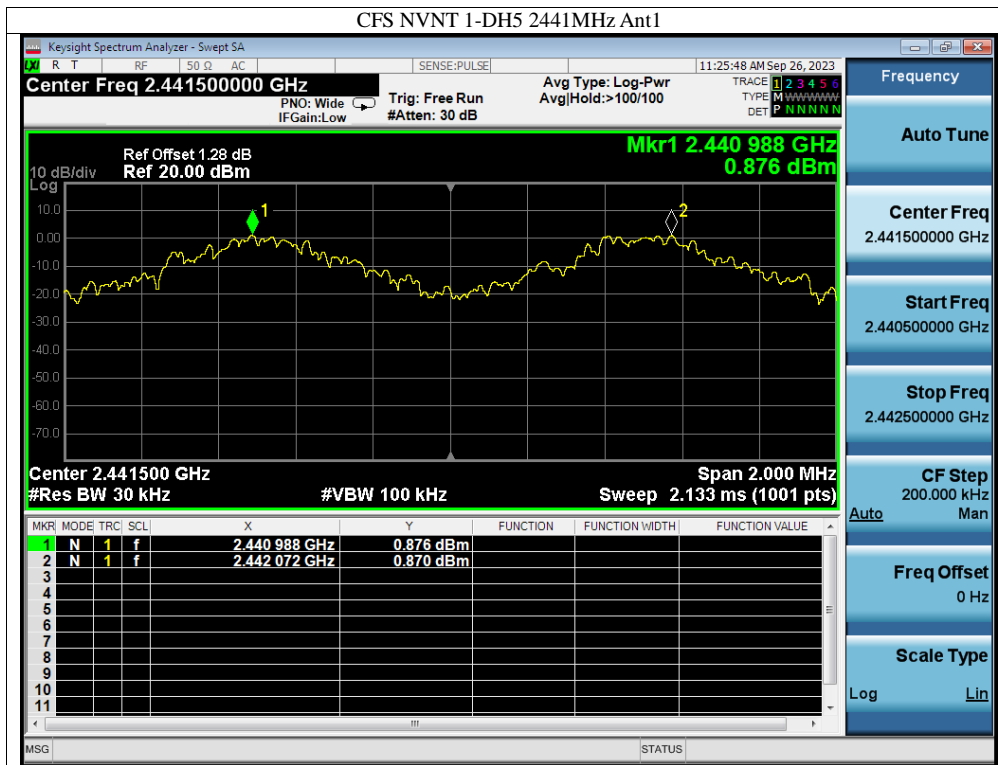

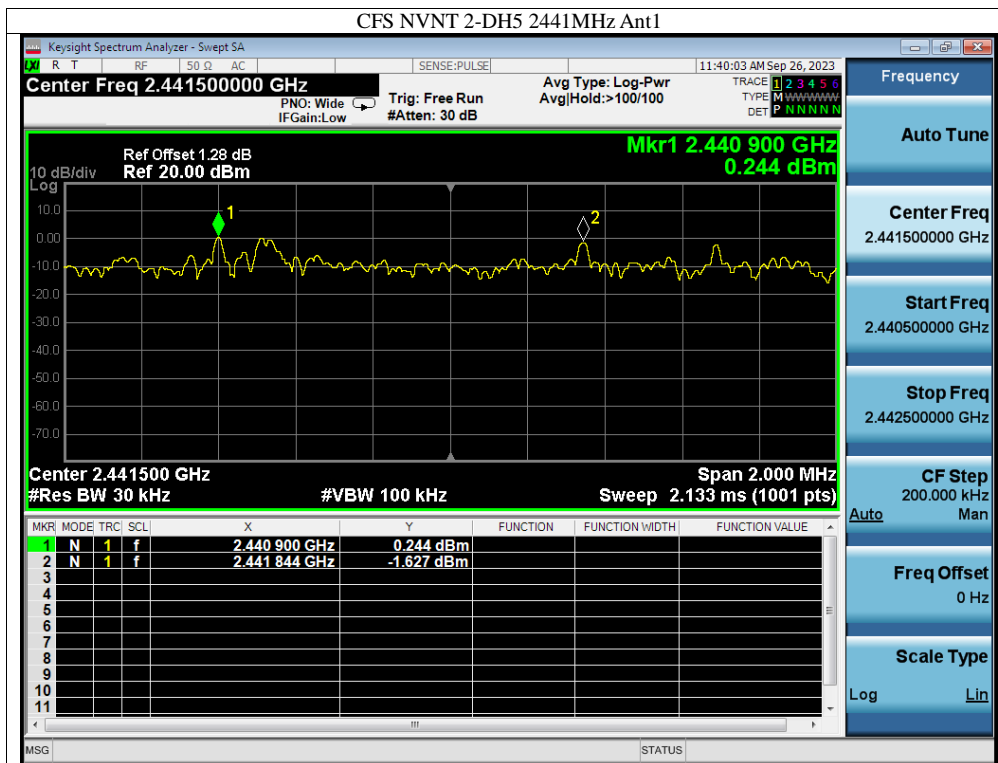
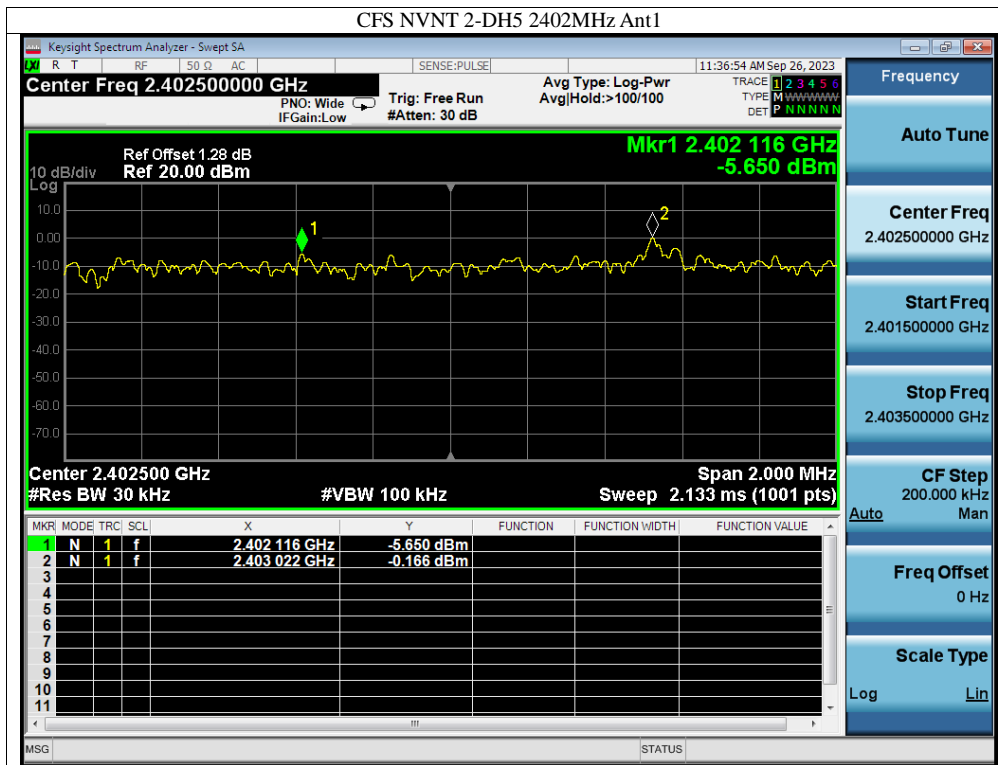

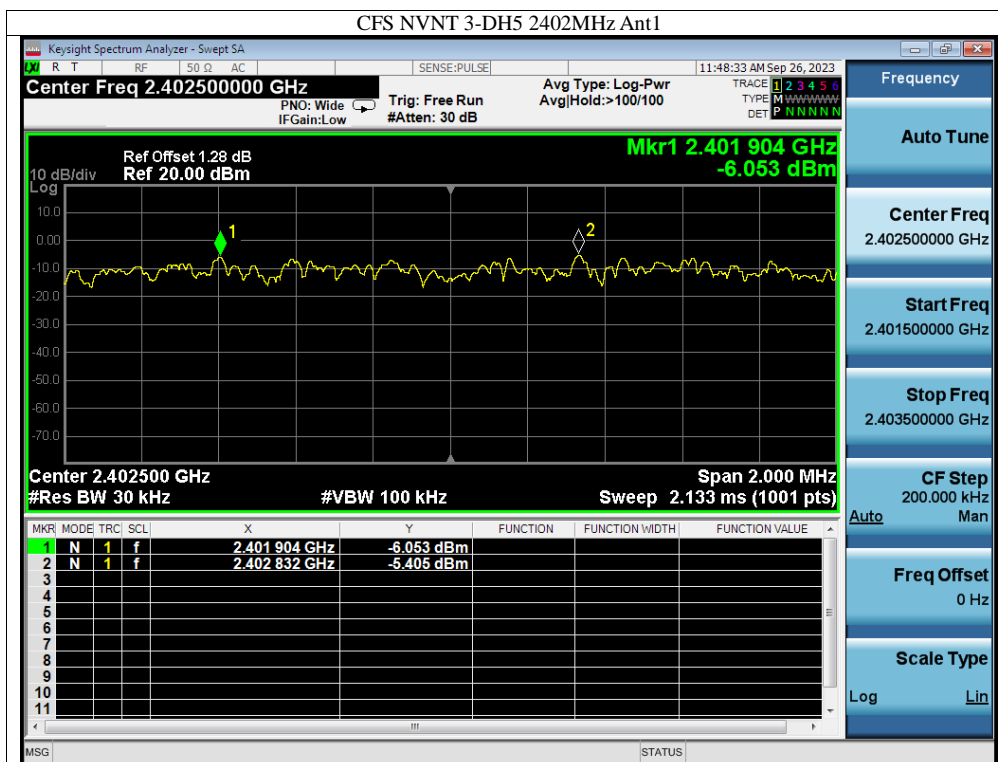
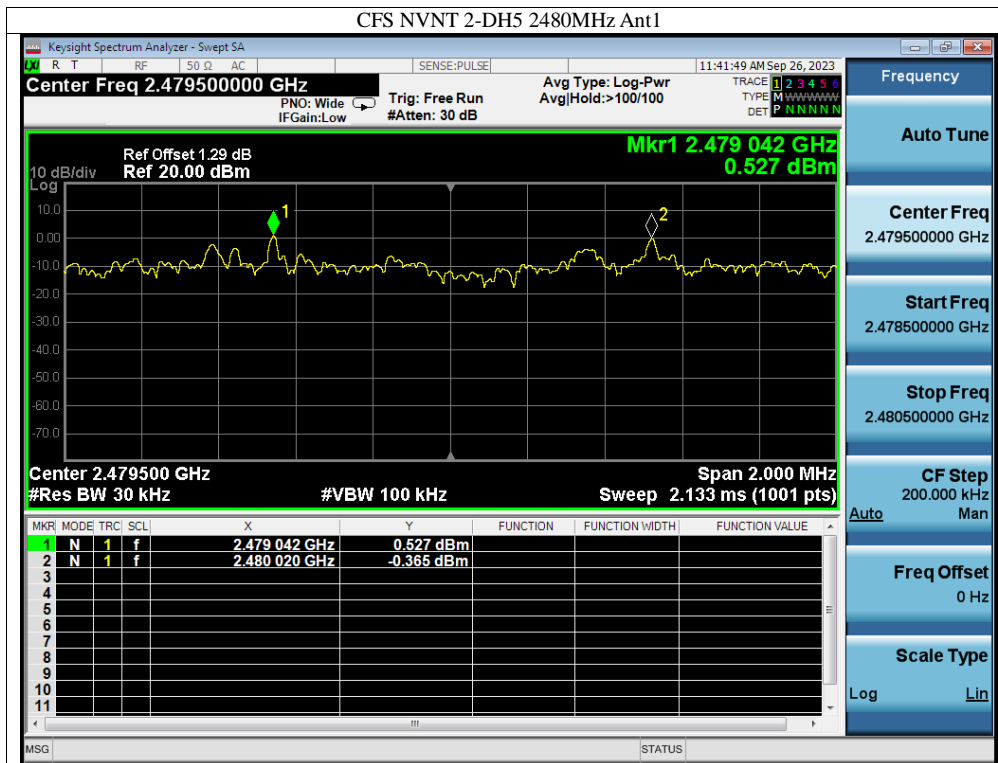

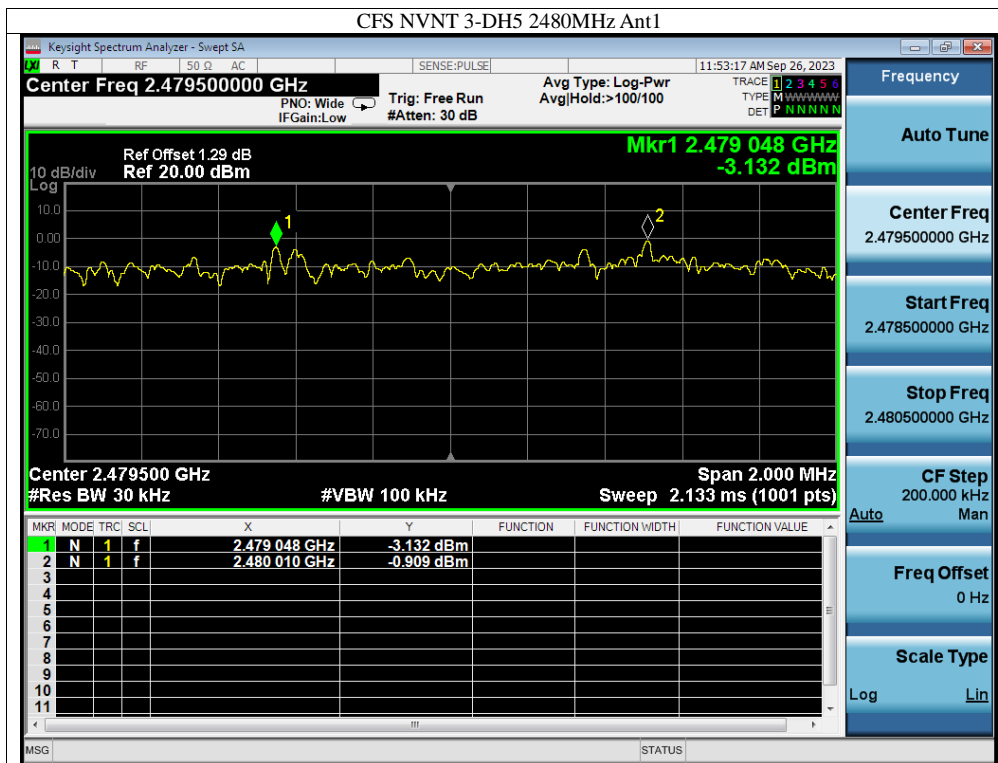
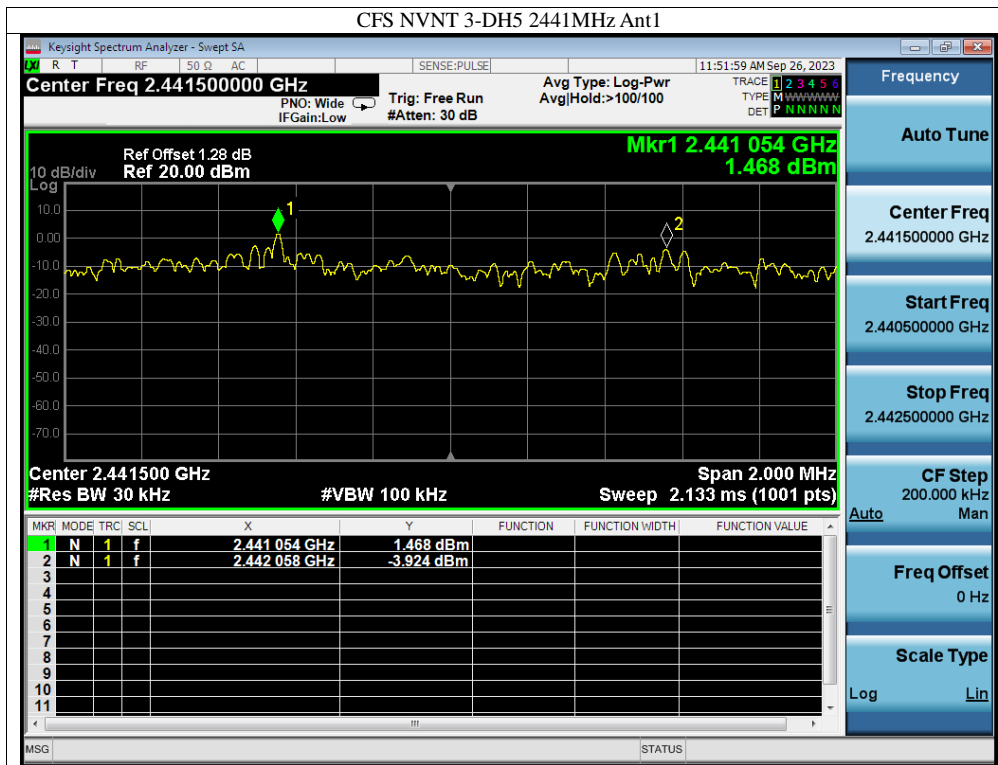

9. 20dB Bandwidth test

9.1 Measurement Procedure

The EUT was operating in hopping mode or could be controlled its channel. Printed out the test result from the spectrum by hard copy function.

9.2 Test SET-UP (Block Diagram of Configuration)

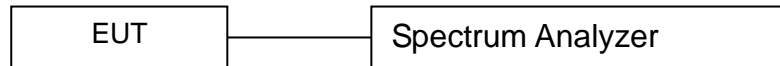

9.3 Measurement Equipment Used:

Test Equipment of Conducted RF					
Equipment	Manufacturer	Model No.	Serial No.	Last Cal.	Due Date
Spectrum Analyzer	Rohde & Schwarz	FSV40	102257	2023/09/18	2024/09/17
EXG Analog Signal Generator	KEYSIGHT	N5173B	MY61253075	2023/09/18	2024/09/17
Vector Signal Generator	Rohde & Schwarz	SMM100A	101899	2023/03/16	2024/03/15
RF Control box	MWRF-test	MW100-RFCB	MW220926GTG	2023/09/18	2024/09/17
Wideband Radio Communication Tester	Rohde & Schwarz	CMW270	102792	2023/03/16	2024/03/15
Wideband Radio Communication Tester	Rohde & Schwarz	CMW500	103235	2023/09/18	2024/09/17
temperature humidity chamber	Espec	SH-241	SH-241-2014	2023/09/18	2024/09/17
RF Test Software	MWRF-test	MTS8310E (Ver. V2/0)	N/A	N/A	N/A

9.4 Measurement Results:

Refer to attached data chart.

Spectrum Detector:	PK	Test Date :	Sep. 26, 2023
Test By:	Zero	Temperature :	24 °C
Test Result:	PASS	Humidity :	53 %
Modulation:	GFSK, π /4-DQPSK, 8DPSK		

Mode	Frequency (MHz)	Antenna	-20 dB Bandwidth (MHz)	Limit -20 dB Bandwidth (MHz)	Verdict
1-DH5	2402	Ant1	0.925	N/A	Pass
1-DH5	2441	Ant1	0.95	N/A	Pass
1-DH5	2480	Ant1	0.958	N/A	Pass
2-DH5	2402	Ant1	1.255	N/A	Pass
2-DH5	2441	Ant1	1.199	N/A	Pass
2-DH5	2480	Ant1	1.231	N/A	Pass
3-DH5	2402	Ant1	1.291	N/A	Pass
3-DH5	2441	Ant1	1.2	N/A	Pass
3-DH5	2480	Ant1	1.239	N/A	Pass

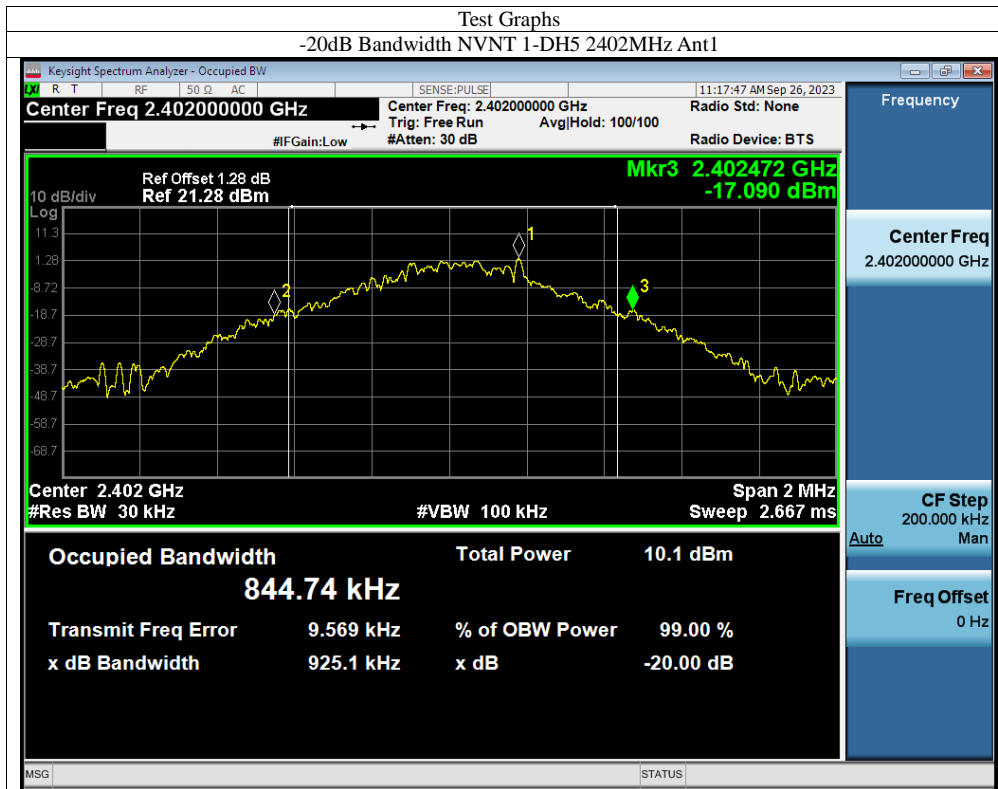

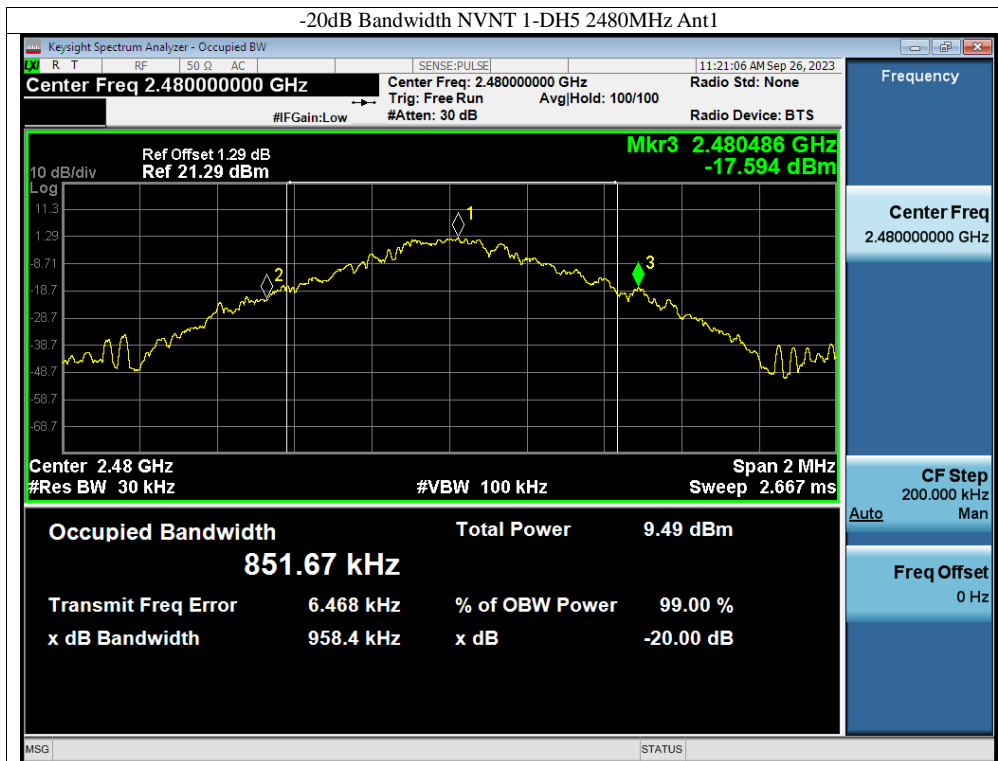

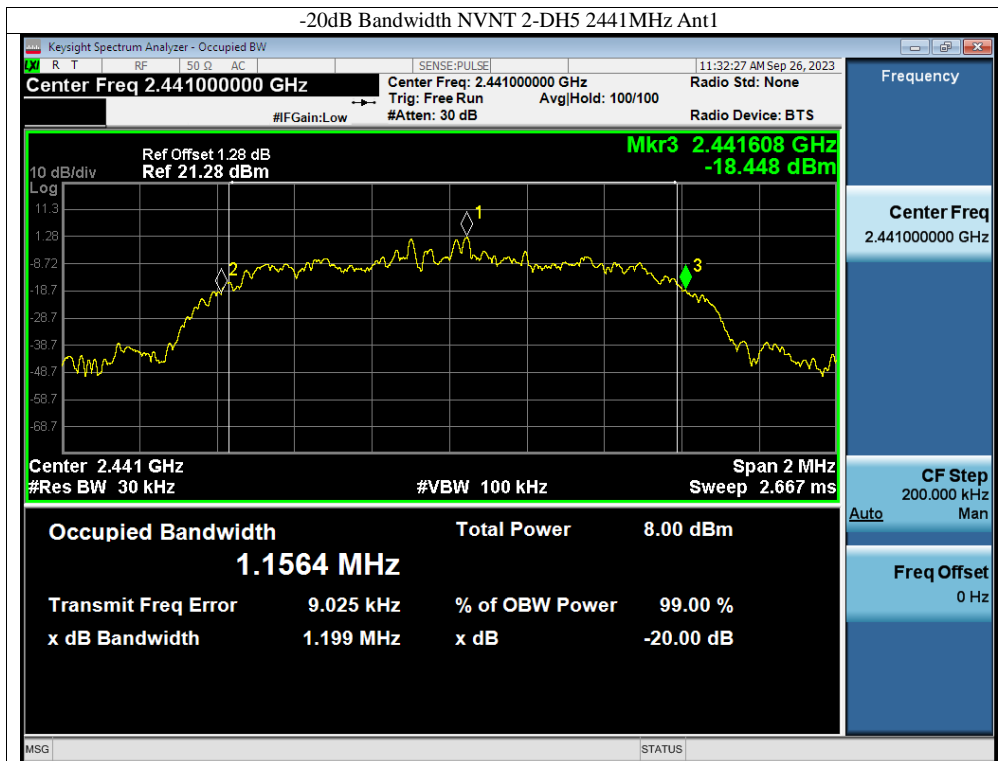

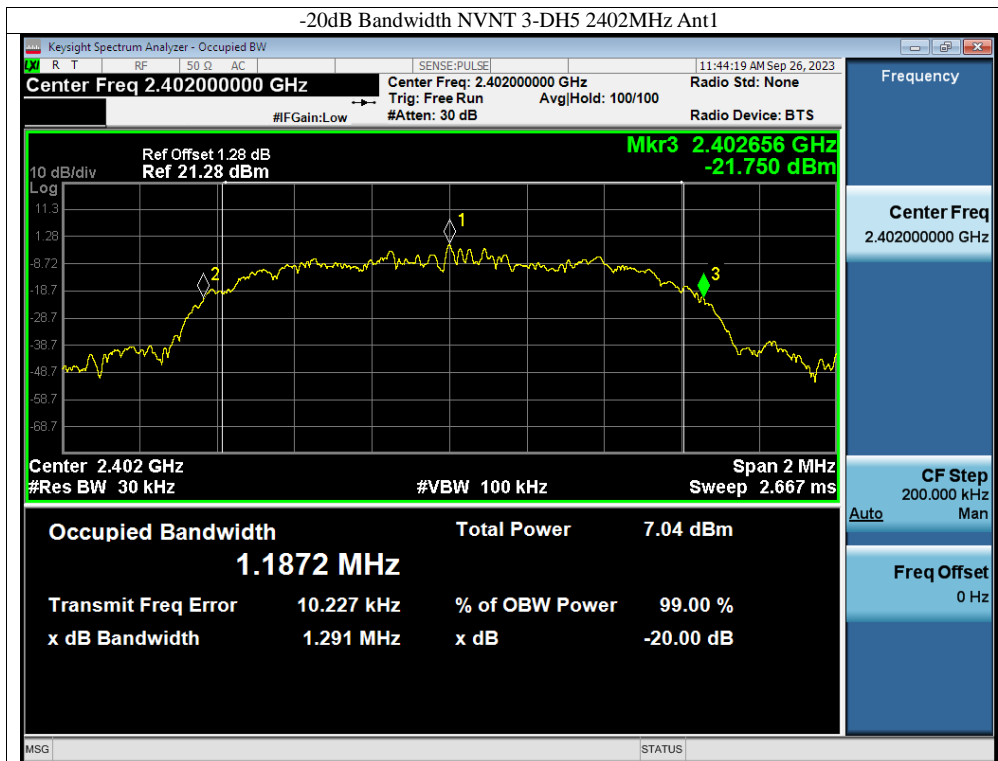

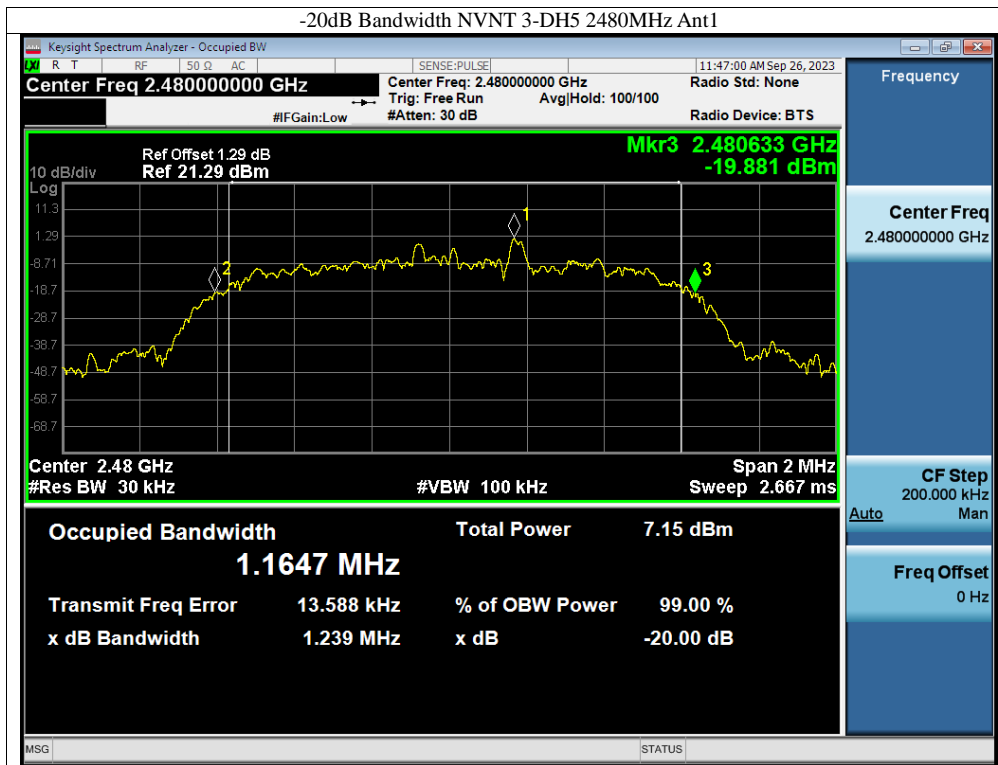

10. Quantity of Hopping Channel Test

10.1 Measurement Procedure

The EUT was operating in hopping mode or could be controlled its channel. Printed out the test result from the spectrum by hard copy function.

10.2 Test SET-UP (Block Diagram of Configuration)

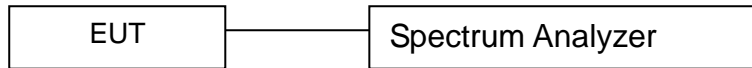

10.3 Measurement Equipment Used:

Test Equipment of Conducted RF					
Equipment	Manufacturer	Model No.	Serial No.	Last Cal.	Due Date
Spectrum Analyzer	Rohde & Schwarz	FSV40	102257	2023/09/18	2024/09/17
EXG Analog Signal Generator	KEYSIGHT	N5173B	MY61253075	2023/09/18	2024/09/17
Vector Signal Generator	Rohde & Schwarz	SMM100A	101899	2023/03/16	2024/03/15
RF Control box	MWRF-test	MW100-RFCB	MW220926GTG	2023/09/18	2024/09/17
Wideband Radio Communication Tester	Rohde & Schwarz	CMW270	102792	2023/03/16	2024/03/15
Wideband Radio Communication Tester	Rohde & Schwarz	CMW500	103235	2023/09/18	2024/09/17
temperature humidity chamber	Espec	SH-241	SH-241-2014	2023/09/18	2024/09/17
RF Test Software	MWRF-test	MTS8310E (Ver. V2/0)	N/A	N/A	N/A

10.4 Measurement Results:

Refer to attached data chart.

Test Mode GFSK, π /4-DQPSK, Test Date : Sep. 26, 2023
 8DPSK
 Test By: Zero Temperature : 24 °C
 Test Result: PASS Humidity : 53 %

Mode	Antenna	Hopping Number	Limit	Verdict
1-DH5	Ant1	79	15	Pass
2-DH5	Ant1	79	15	Pass
3-DH5	Ant1	79	15	Pass

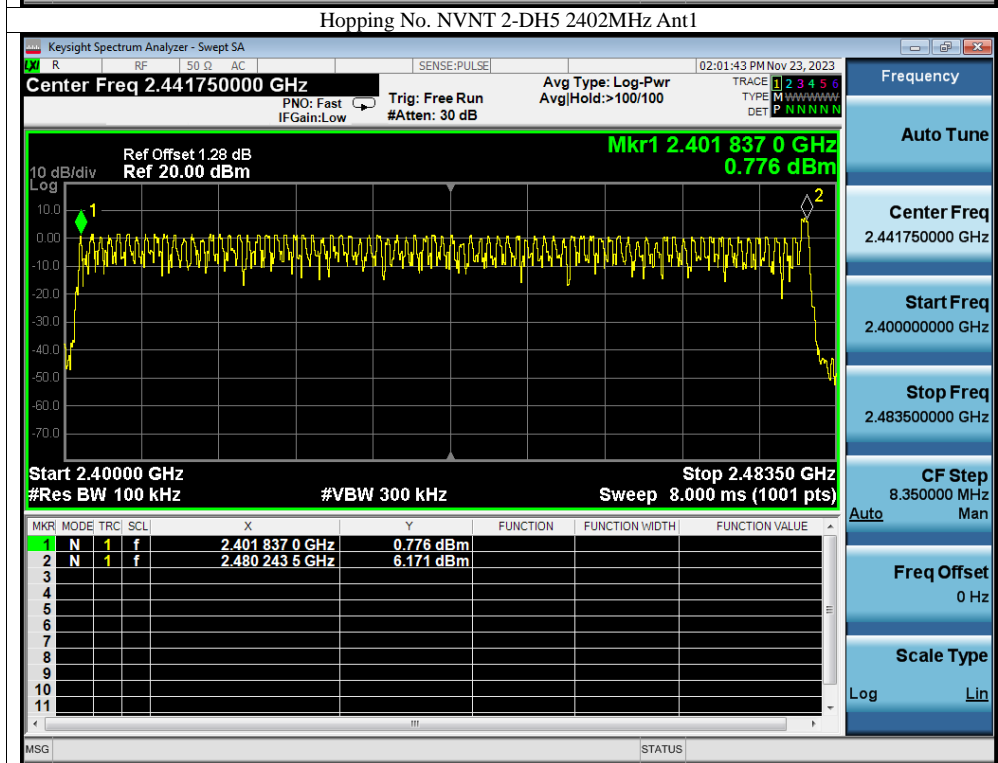
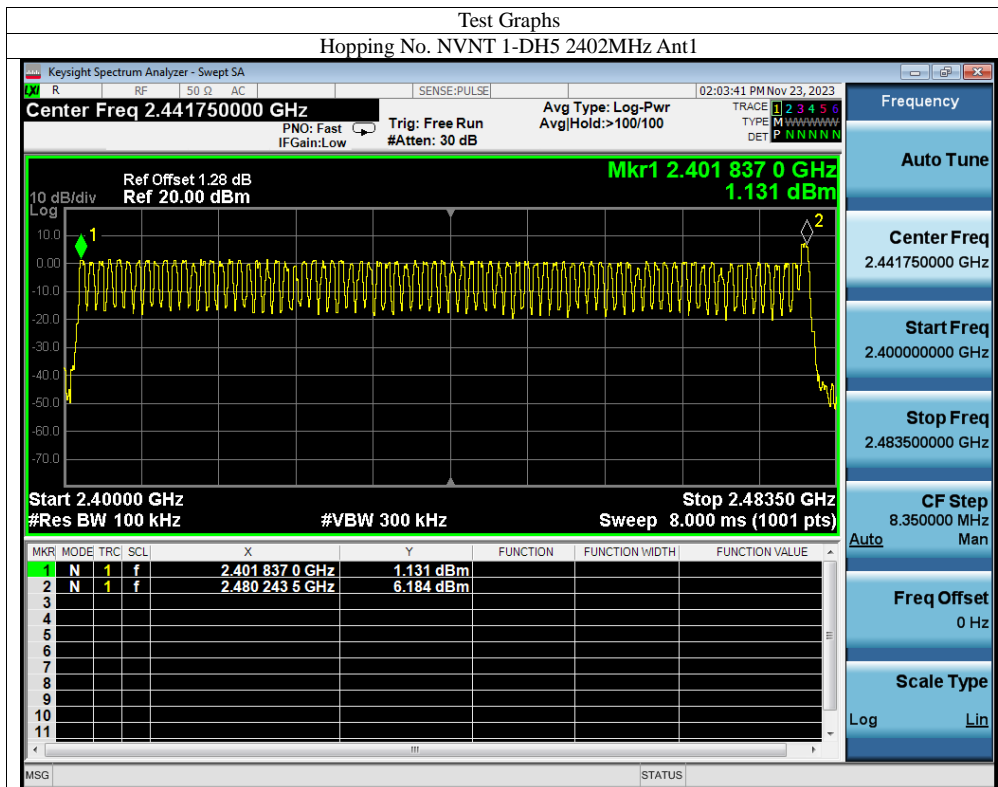

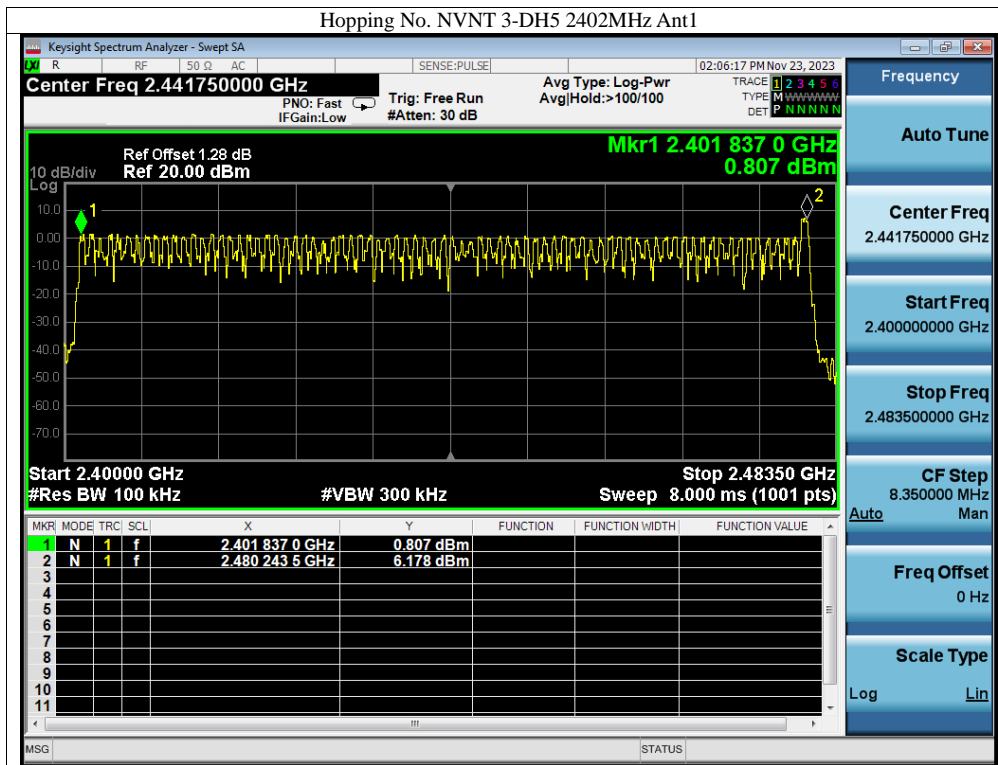

11. Time of Occupancy (Dwell Time) test

11.1 Test Description

The Equipment Under Test (EUT) was set up to perform the dwell time measurements. The EUT was connected to the spectrum analyzer via a short coax cable. The dwell time is calculated by:

$$\text{Dwell time} = \text{time slot length} * \text{hop rate} / \text{number of hopping channels} * 31.6\text{s}$$

with:

- hop rate = $1600 * 1/\text{s}$ for DH1 packets = 1600 s^{-1}
- hop rate = $1600/3 * 1/\text{s}$ for DH3 packets = 533.33 s^{-1}
- number of hopping channels = 79
- $31.6 \text{ s} = 0.4 \text{ seconds multiplied by the number of hopping channels} = 0.4 \text{ s} * 79$

The highest value of the dwell time is reported.

11.2 Test SET-UP (Block Diagram of Configuration)

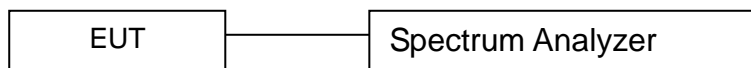

11.3 Measurement Equipment Used:

Test Equipment of Conducted RF					
Equipment	Manufacturer	Model No.	Serial No.	Last Cal.	Due Date
Spectrum Analyzer	Rohde & Schwarz	FSV40	102257	2023/09/18	2024/09/17
EXG Analog Signal Generator	KEYSIGHT	N5173B	MY61253075	2023/09/18	2024/09/17
Vector Signal Generator	Rohde & Schwarz	SMM100A	101899	2023/03/16	2024/03/15
RF Control box	MWRF-test	MW100-RFCB	MW220926GTG	2023/09/18	2024/09/17
Wideband Radio Communication Tester	Rohde & Schwarz	CMW270	102792	2023/03/16	2024/03/15
Wideband Radio Communication Tester	Rohde & Schwarz	CMW500	103235	2023/09/18	2024/09/17
temperature humidity chamber	Espec	SH-241	SH-241-2014	2023/09/18	2024/09/17
RF Test Software	MWRF-test	MTS8310E (Ver. V2/0)	N/A	N/A	N/A

11.4 Test Requirements / Limits

FCC Part 15, Subpart C, §15.247 (a) (1) (iii)

Frequency hopping systems in the 2400-2483.5 MHz band shall use at least 15 channels. The average time of occupancy on any channel shall not be greater than 0.4

seconds within a period of 0.4 seconds multiplied by the number of hopping channels employed. Since the Bluetooth technology uses 79 channels this period is calculated to be 31.6seconds. Refer to attached data chart.

Modulation: GFSK, $\pi/4$ -DQPSK, 8DPSK Test Date : Sep. 26, 2023
 Test By: Zero Temperature : 24 °C
 Test Result: PASS Humidity : 53 %

11.5 Test result

Mode	Frequency (MHz)	Antenna	Pulse Time (ms)	Total Dwell Time (ms)	Burst Count	Period Time (ms)	Limit (ms)	Verdict
1-DH5	2402	Ant1	2.885	144.25	50	31600	400	Pass
1-DH5	2441	Ant1	2.886	132.756	46	31600	400	Pass
1-DH5	2480	Ant1	2.886	135.642	47	31600	400	Pass
2-DH5	2402	Ant1	2.891	112.749	39	31600	400	Pass
2-DH5	2441	Ant1	2.892	141.708	49	31600	400	Pass
2-DH5	2480	Ant1	2.892	130.14	45	31600	400	Pass
3-DH5	2402	Ant1	2.892	161.952	56	31600	400	Pass
3-DH5	2441	Ant1	2.892	124.356	43	31600	400	Pass
3-DH5	2480	Ant1	2.893	159.115	55	31600	400	Pass

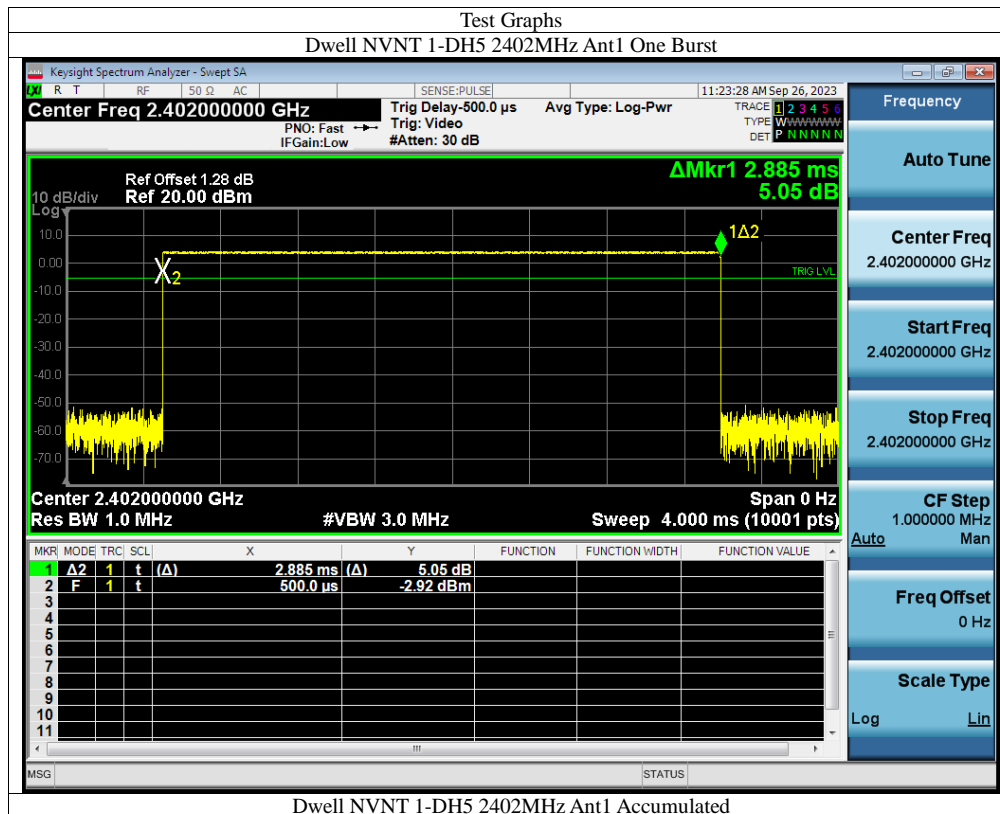

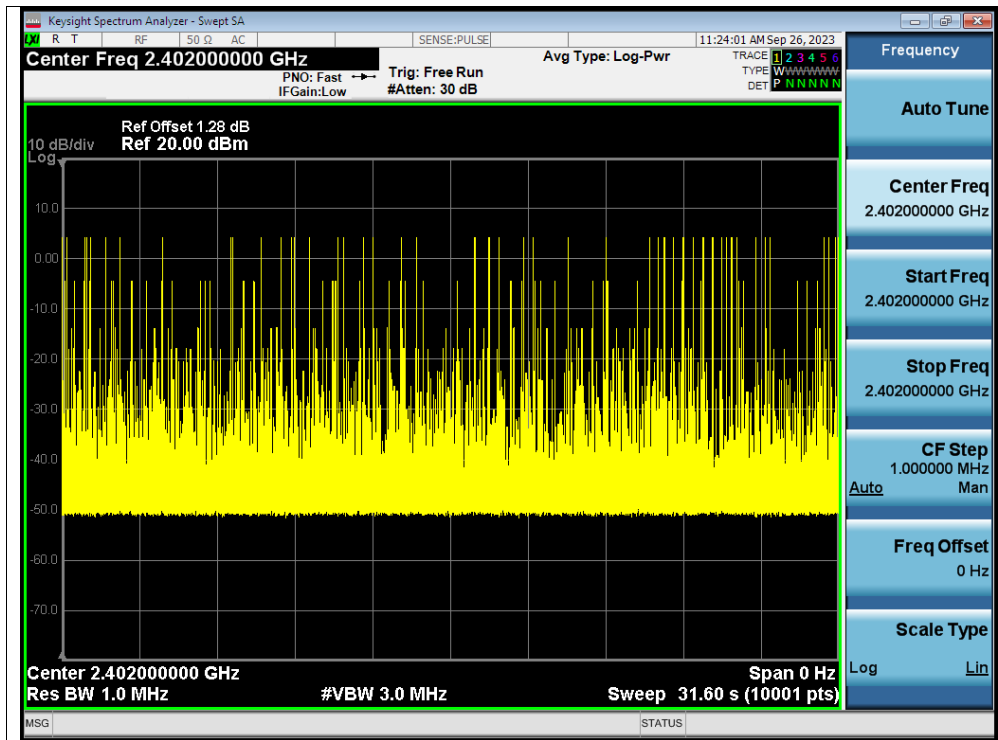

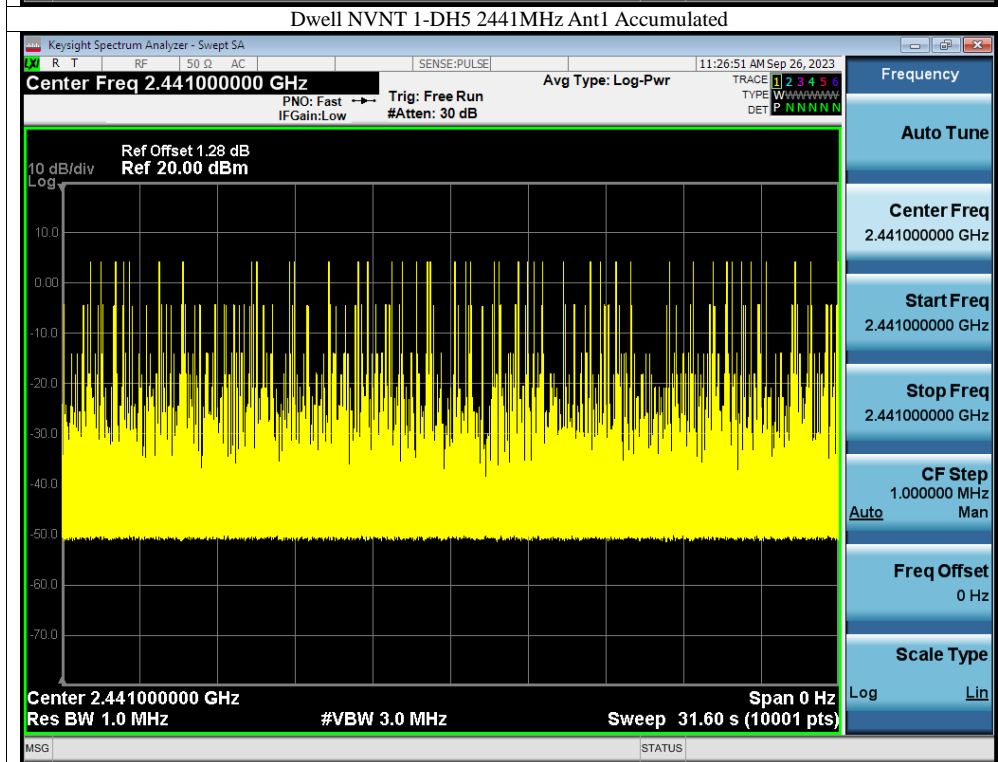
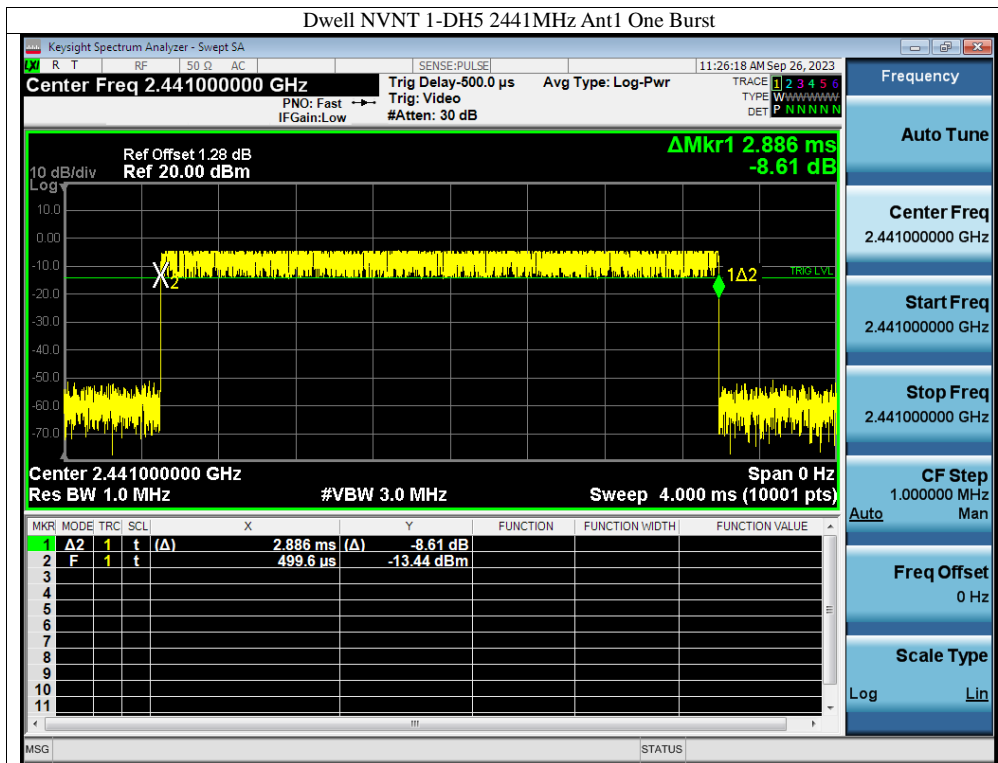

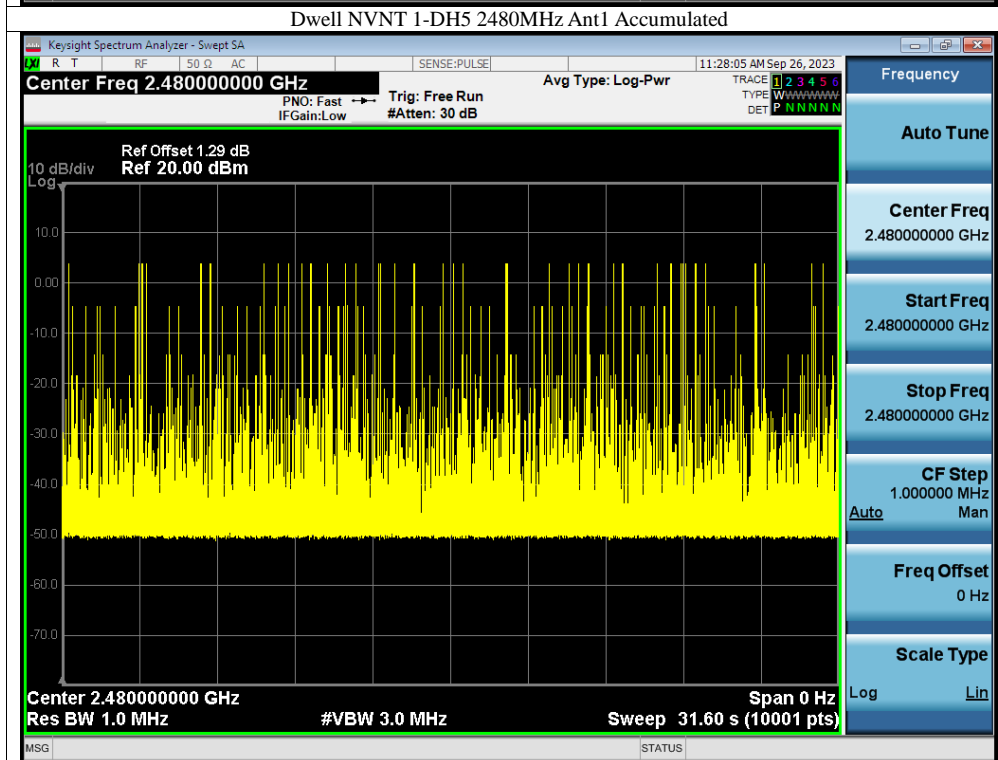
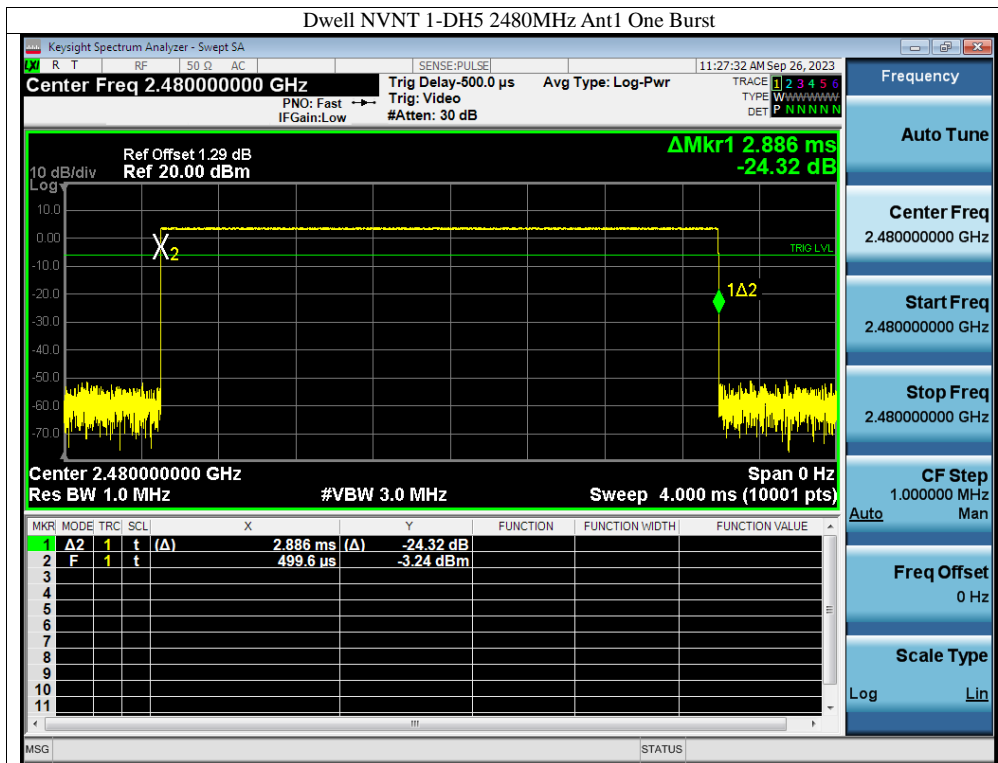

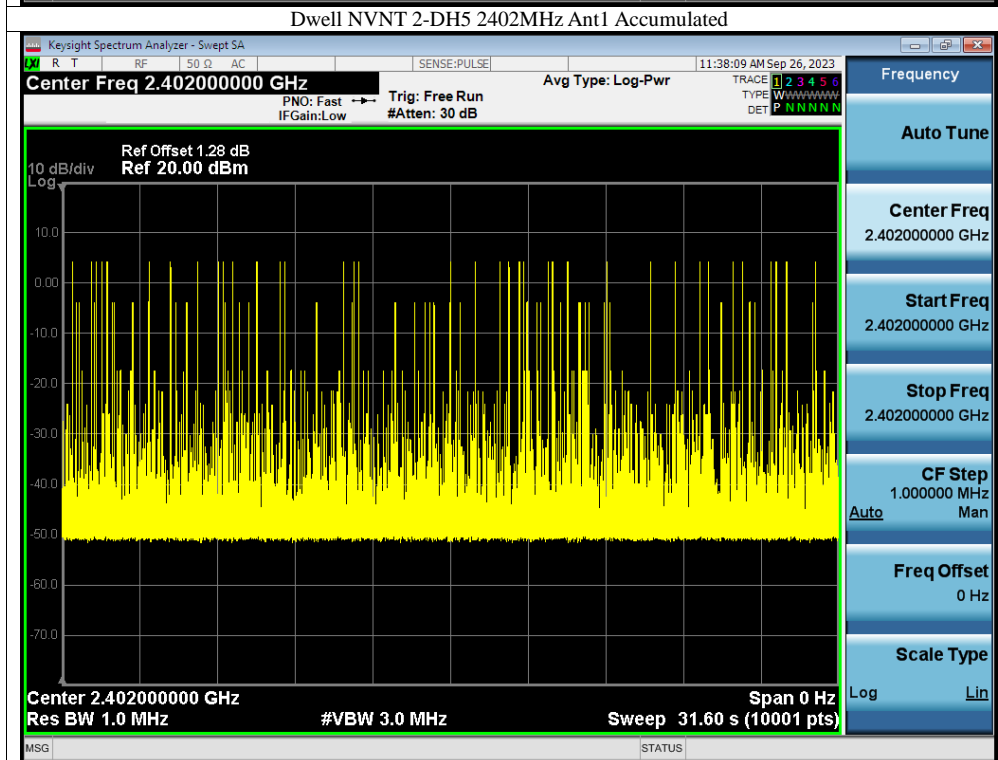
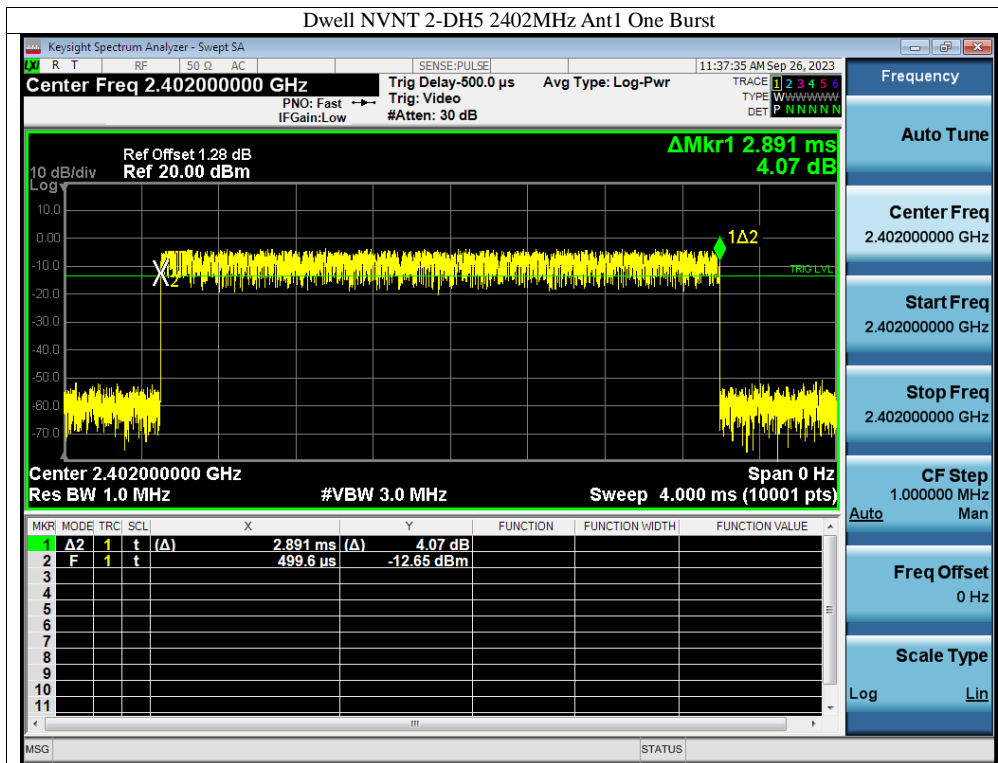

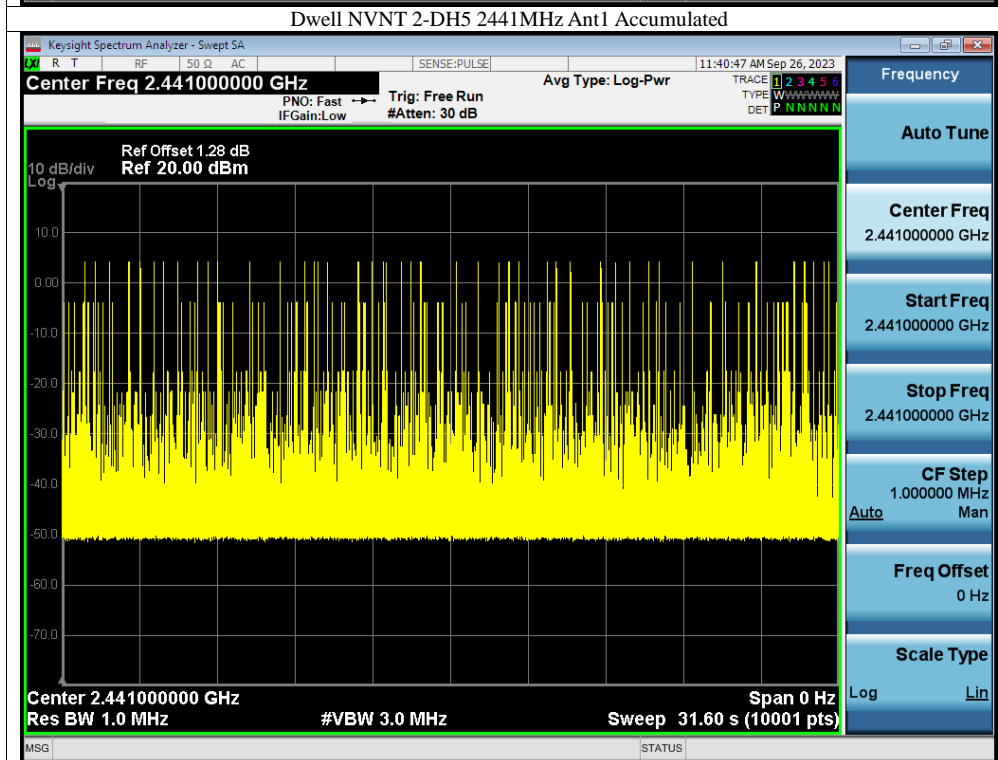
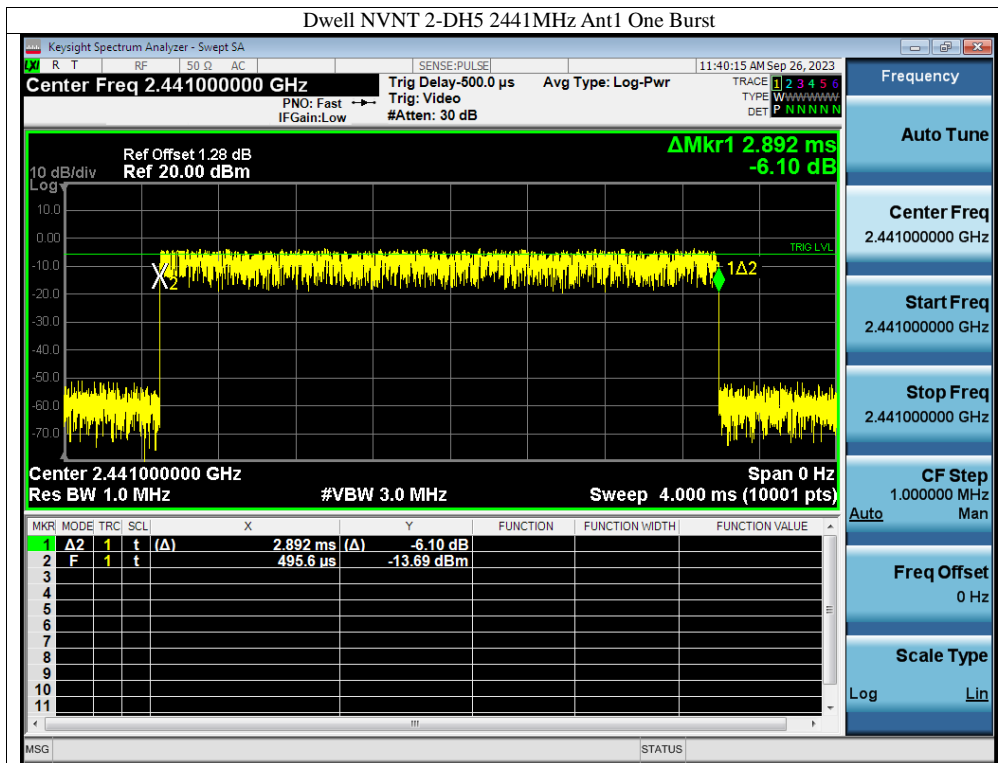

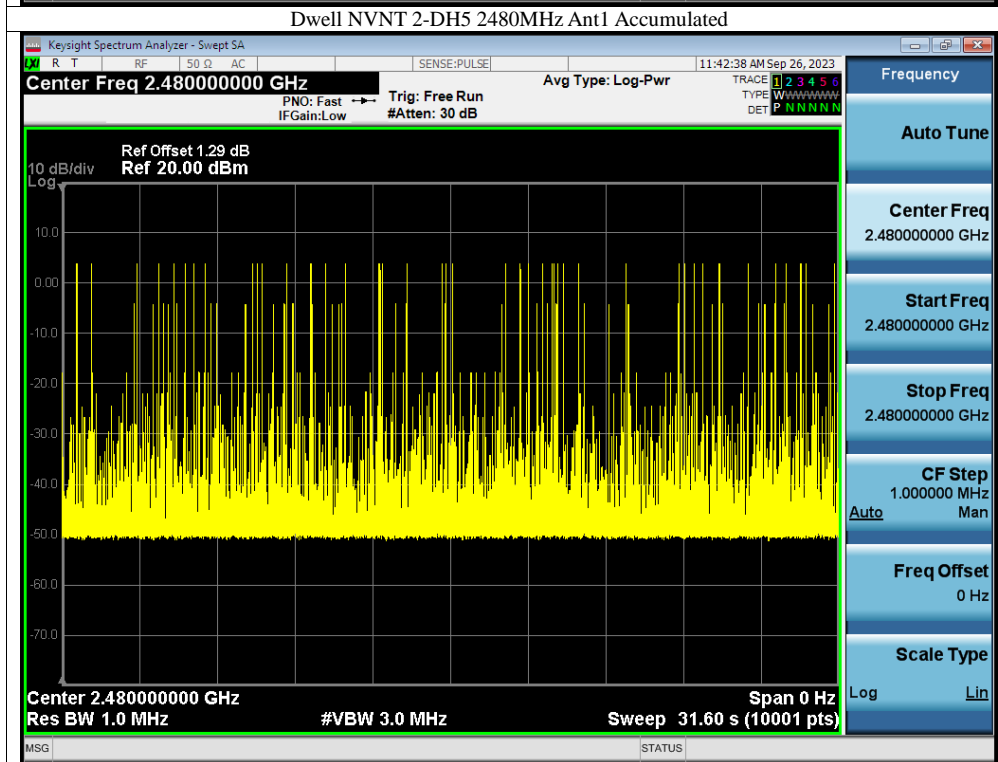
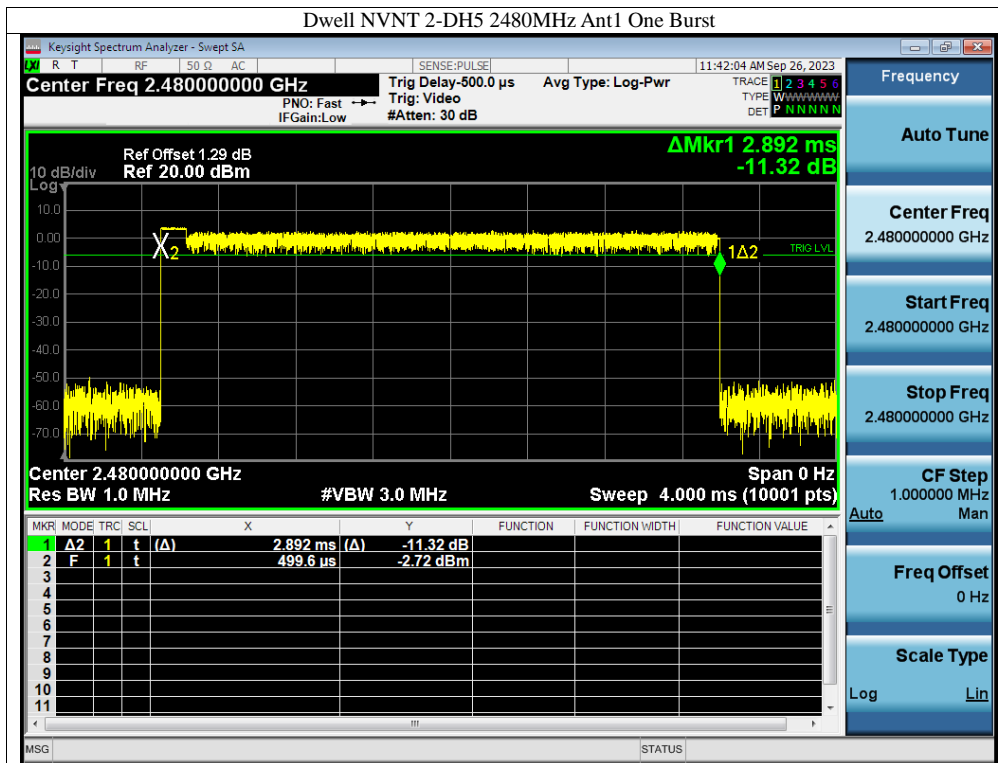

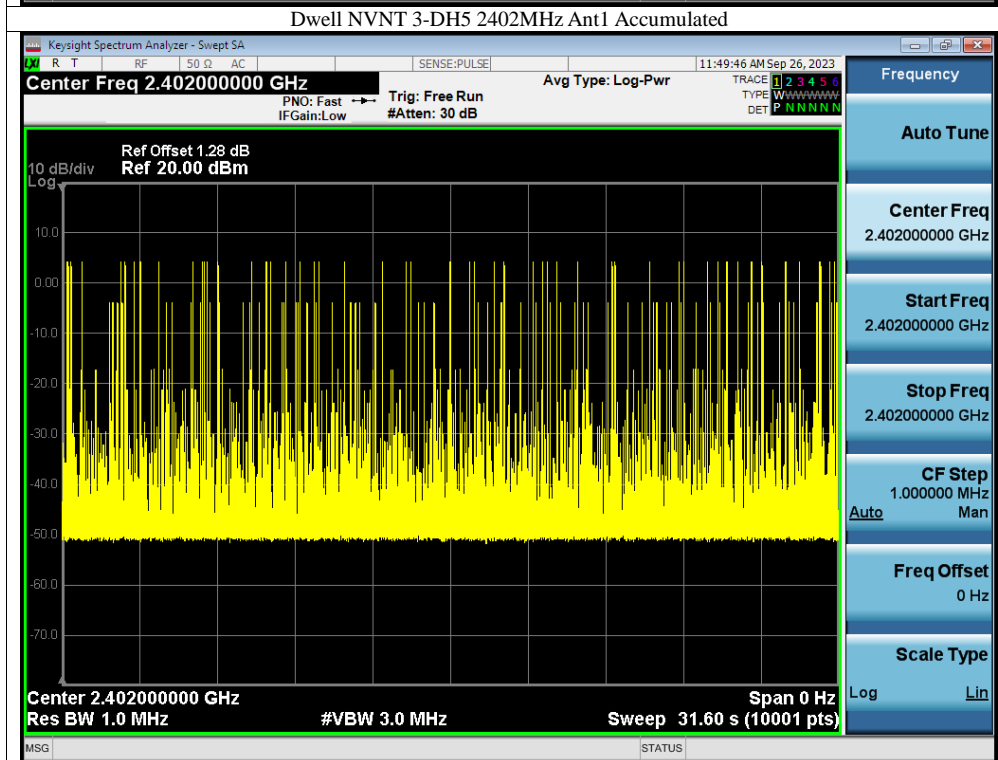
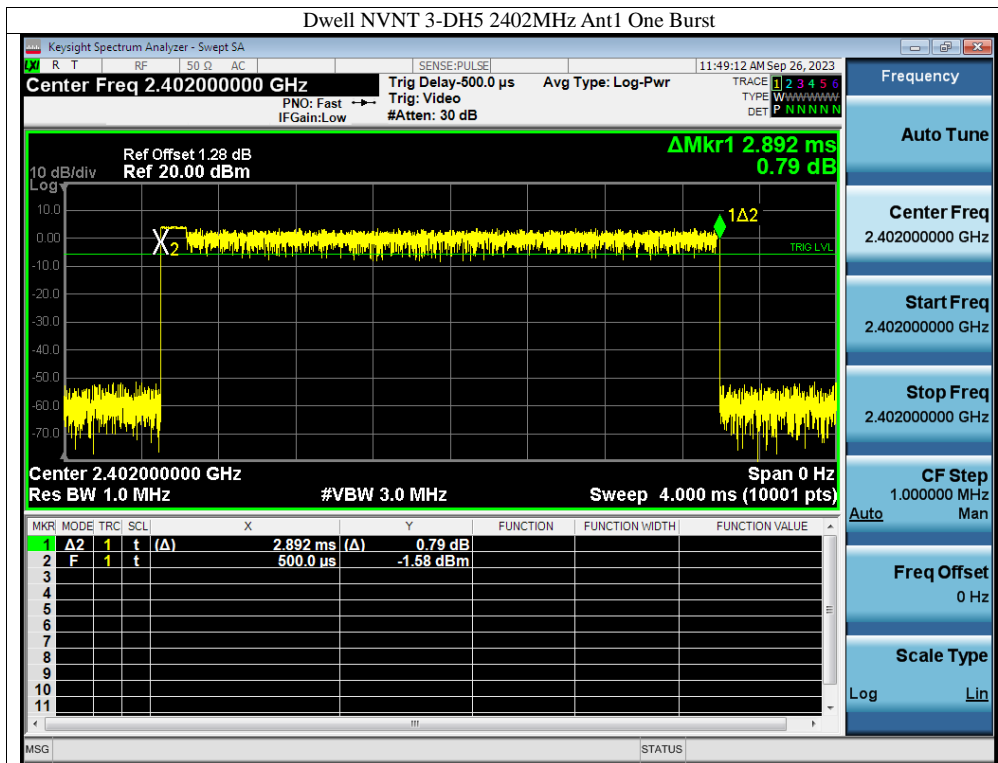

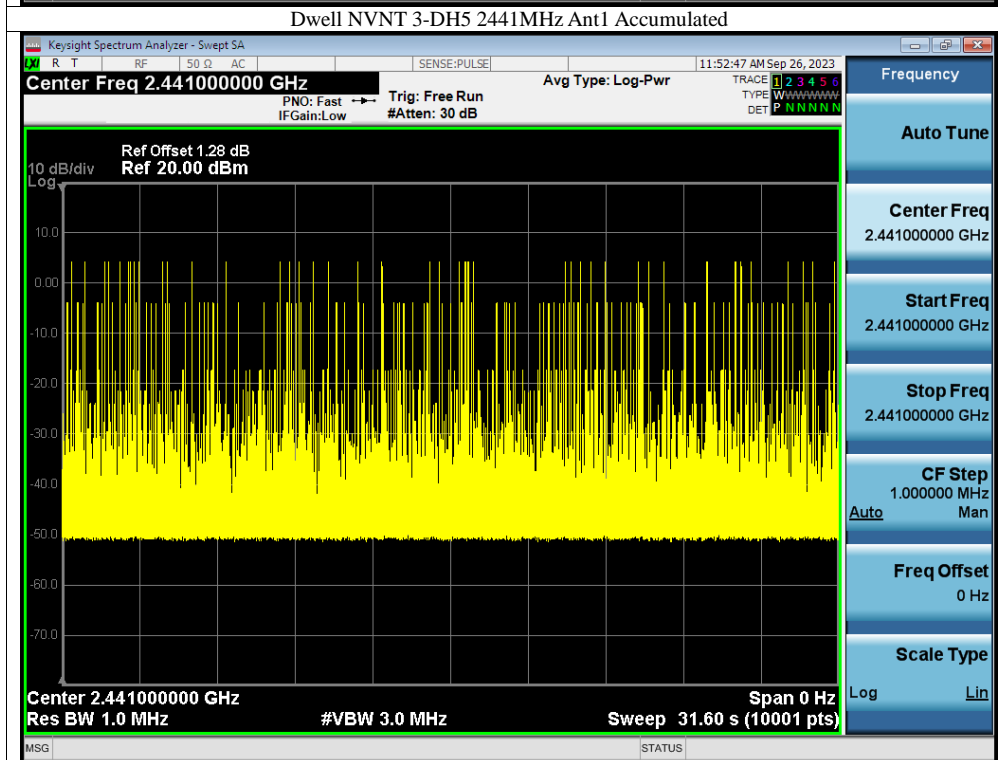
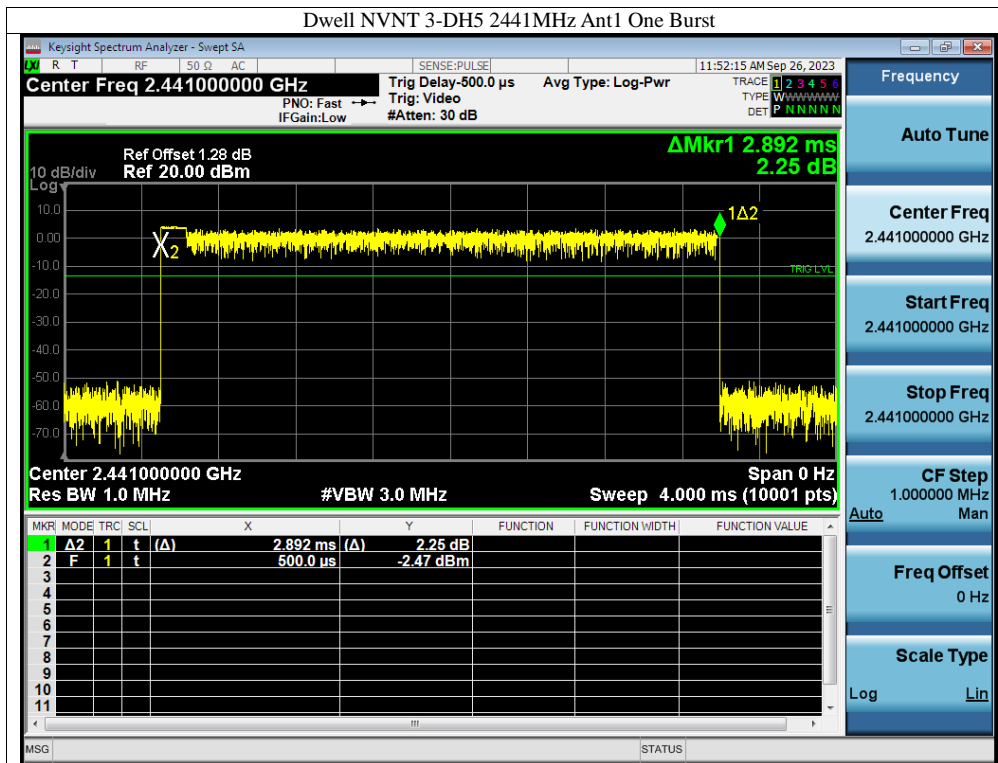

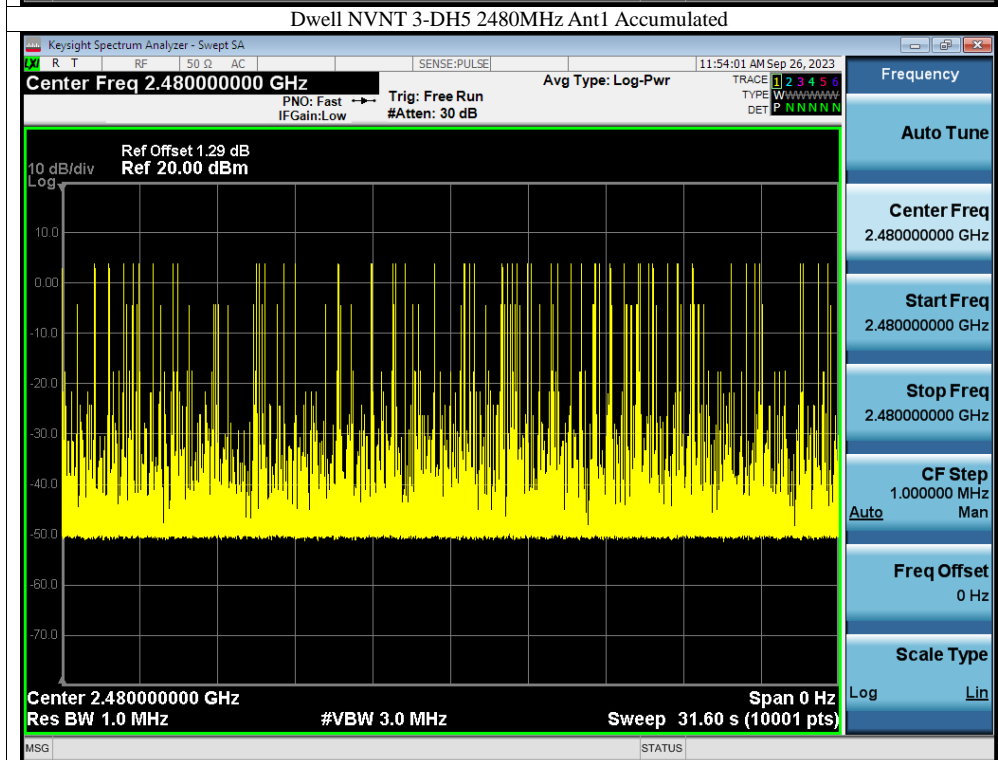
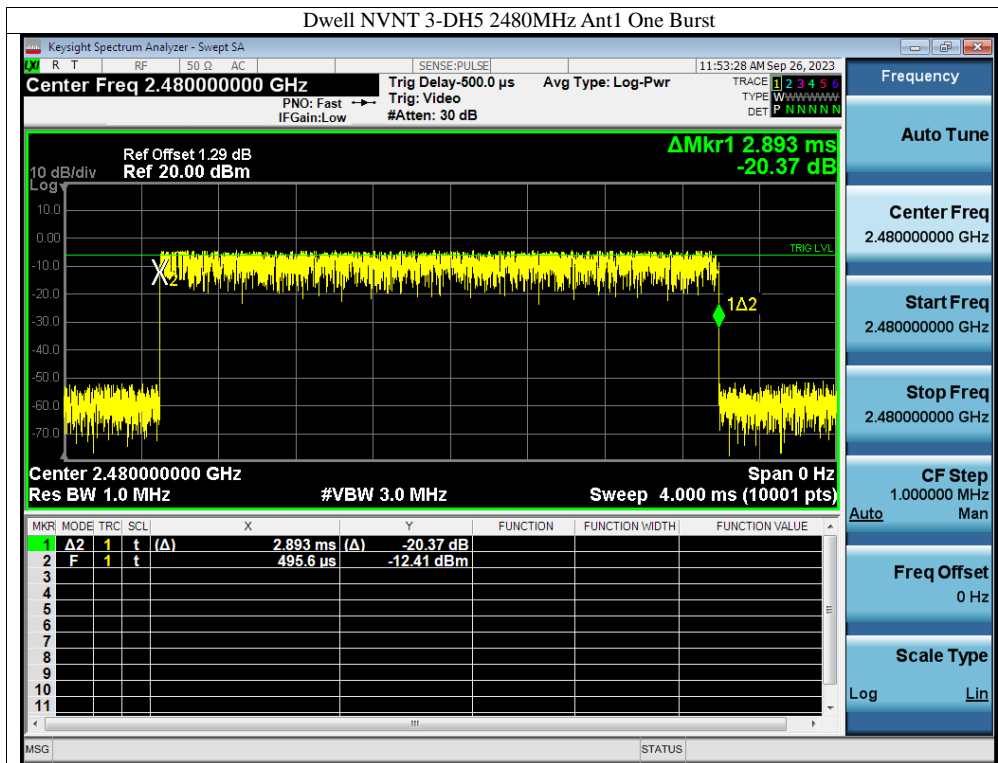

12. MAXIMUM PEAK OUTPUT POWER TEST

12.1 Measurement Procedure

- Check the calibration of the measuring instrument(SA) using either an internal calibrator or a known signal from an external generator.
- Turn on the EUT and connect it to measurement instrument. Then set it to any one convenient frequency within its operating range. Set a reference level on the measuring instrument equal to the highest peak value.
- The center frequency of the spectrum analyzer is set to the fundamental frequency and using proper RBW and VBW setting.
- Measure the captured power within the band and recording the plot.
- Repeat above procedures until all frequencies required were complete.

12.2 Test SET-UP (Block Diagram of Configuration)

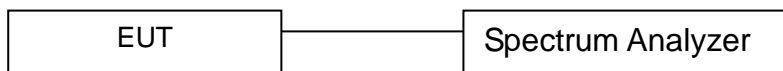

12.3 Measurement Equipment Used:

Test Equipment of Conducted RF					
Equipment	Manufacturer	Model No.	Serial No.	Last Cal.	Due Date
Spectrum Analyzer	Rohde & Schwarz	FSV40	102257	2023/09/18	2024/09/17
EXG Analog Signal Generator	KEYSIGHT	N5173B	MY61253075	2023/09/18	2024/09/17
Vector Signal Generator	Rohde & Schwarz	SMM100A	101899	2023/03/16	2024/03/15
RF Control box	MWRF-test	MW100-RFCB	MW220926GTG	2023/09/18	2024/09/17
Wideband Radio Communication Tester	Rohde & Schwarz	CMW270	102792	2023/03/16	2024/03/15
Wideband Radio Communication Tester	Rohde & Schwarz	CMW500	103235	2023/09/18	2024/09/17
temperature humidity chamber	Espec	SH-241	SH-241-2014	2023/09/18	2024/09/17
RF Test Software	MWRF-test	MTS8310E (Ver. V2/0)	N/A	N/A	N/A

12.4 Measurement Results:

Refer to attached data chart.

Spectrum Detector:	PK	Test Date :	Sep. 26, 2023
Test By:	Zero	Temperature :	24 °C
Test Result:	PASS	Humidity :	53 %

Mode	Frequency (MHz)	Antenna	Conducted Power (dBm)	Duty Factor (dB)	Total Power (dBm)	Limit (dBm)	Verdict
1-DH5	2402	Ant1	4.34	0	4.34	21	Pass
1-DH5	2441	Ant1	4.21	0	4.21	21	Pass
1-DH5	2480	Ant1	3.89	0	3.89	21	Pass
2-DH5	2402	Ant1	4.33	0	4.33	21	Pass
2-DH5	2441	Ant1	4.21	0	4.21	21	Pass
2-DH5	2480	Ant1	3.89	0	3.89	21	Pass
3-DH5	2402	Ant1	4.29	0	4.29	21	Pass
3-DH5	2441	Ant1	4.14	0	4.14	21	Pass
3-DH5	2480	Ant1	3.81	0	3.81	21	Pass

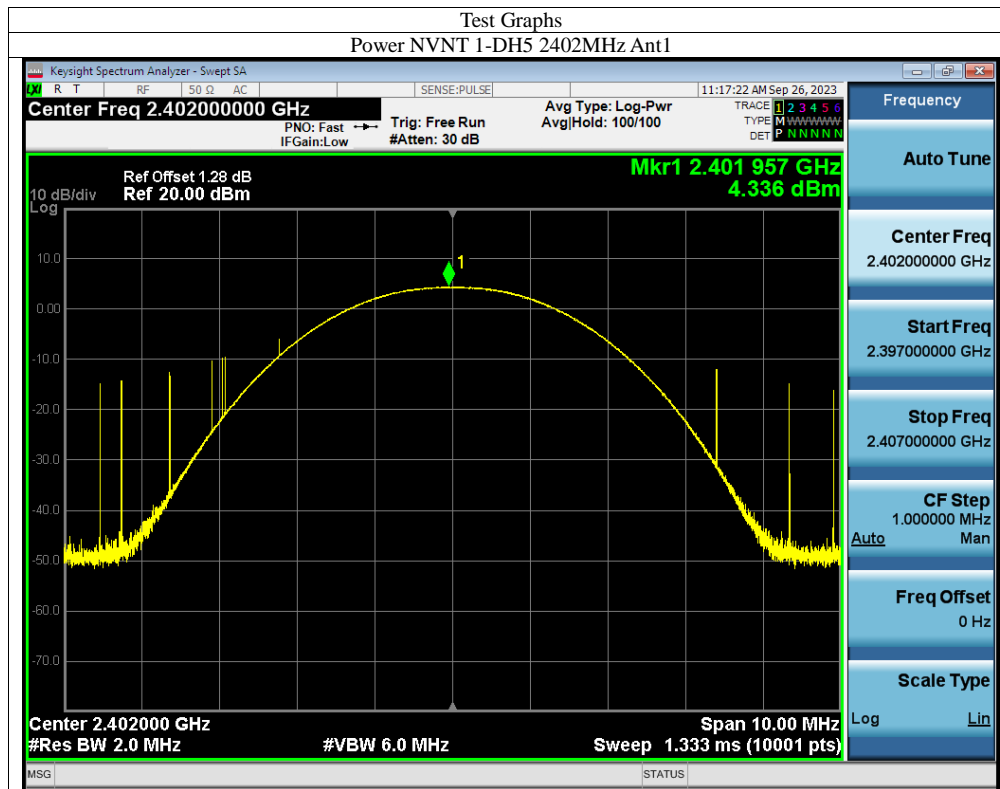

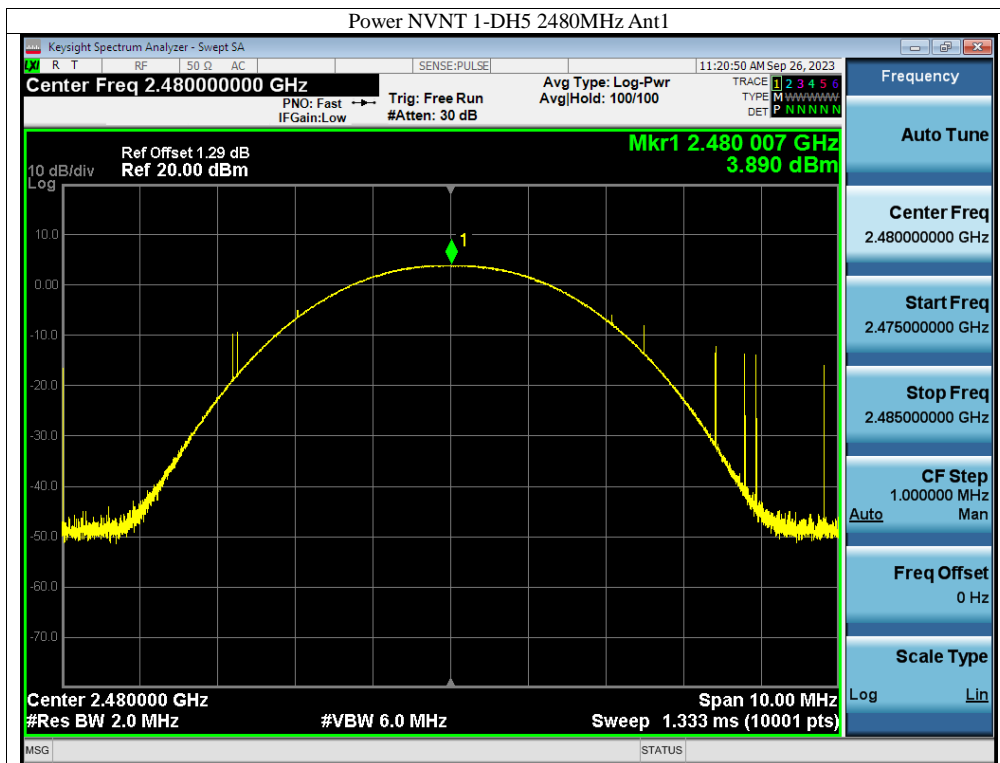
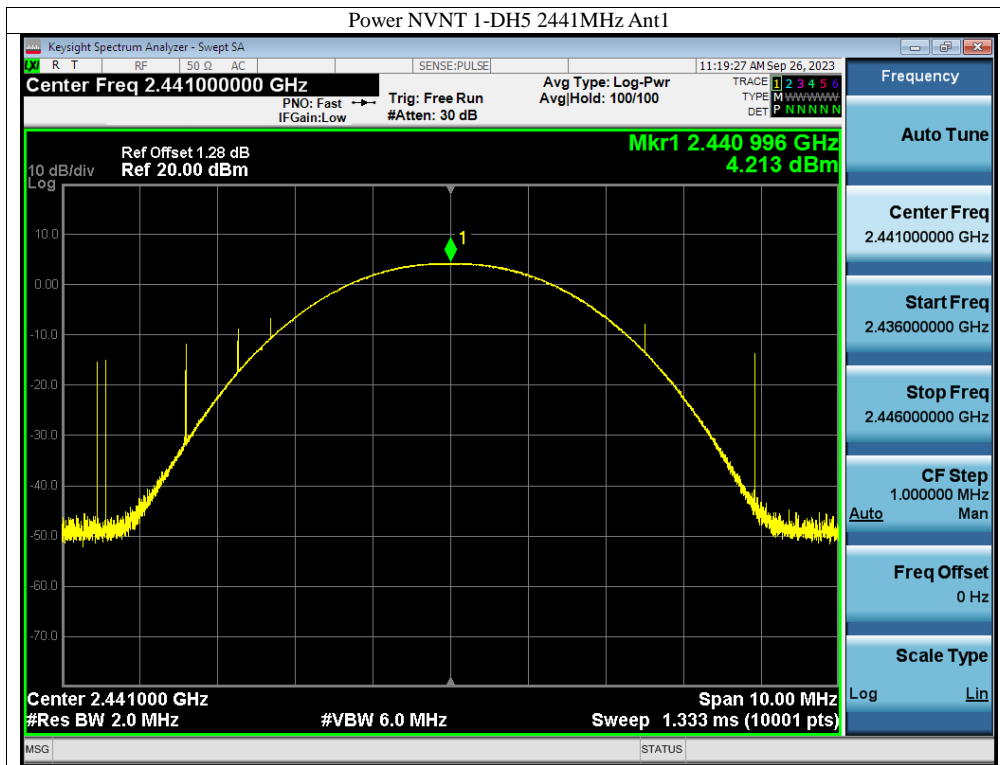

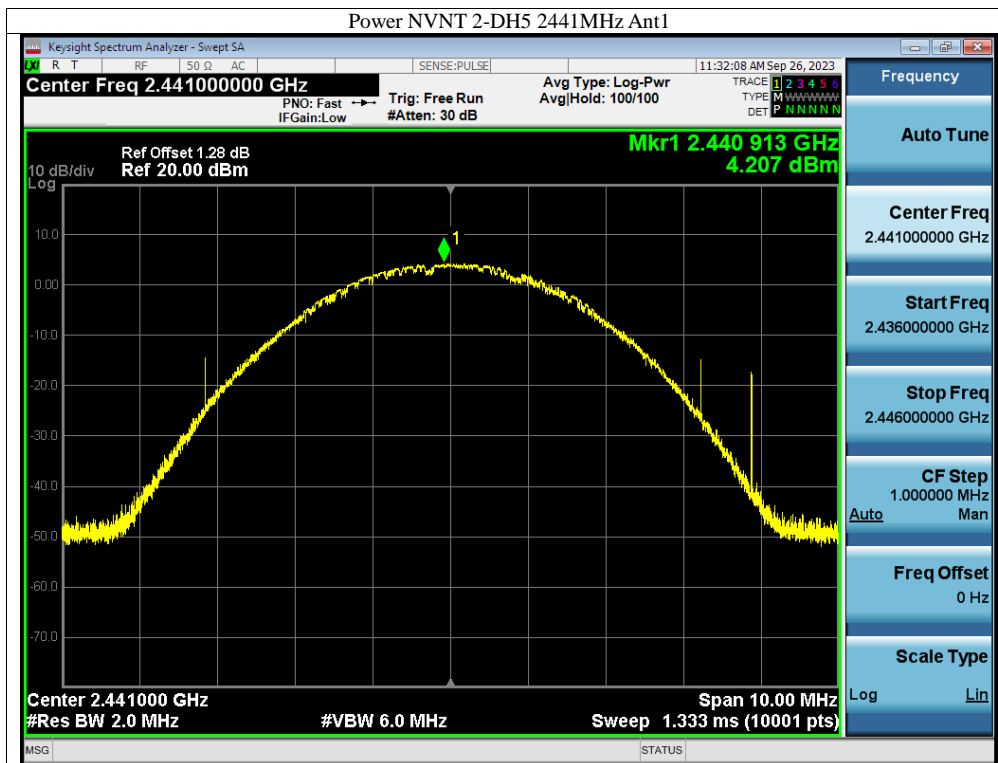
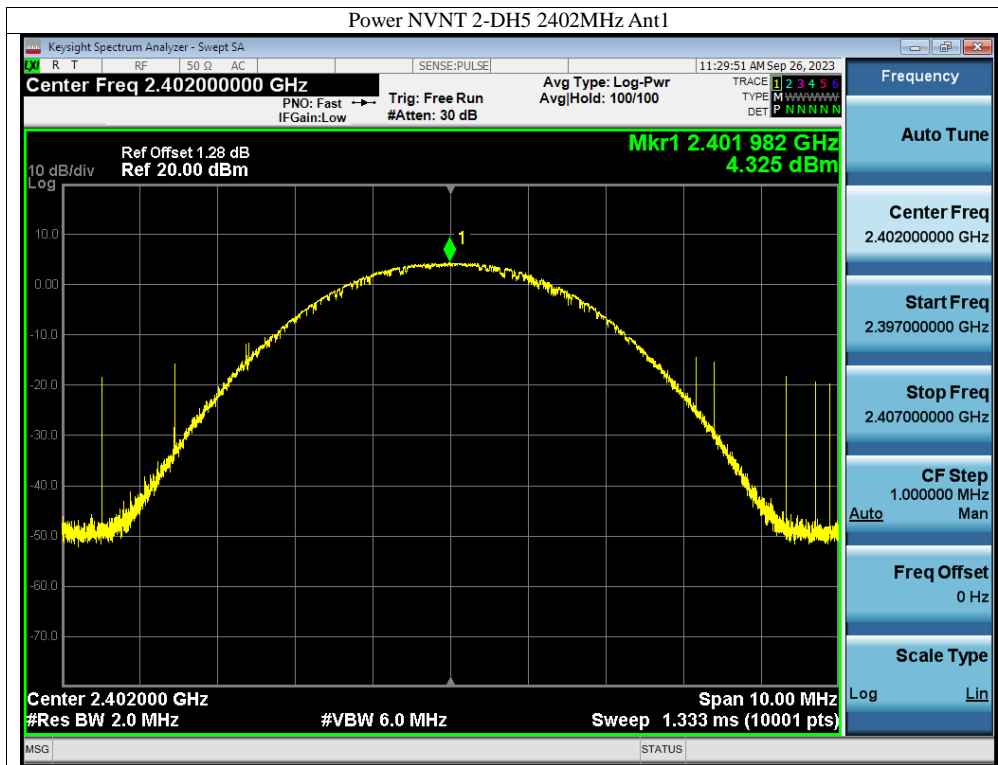

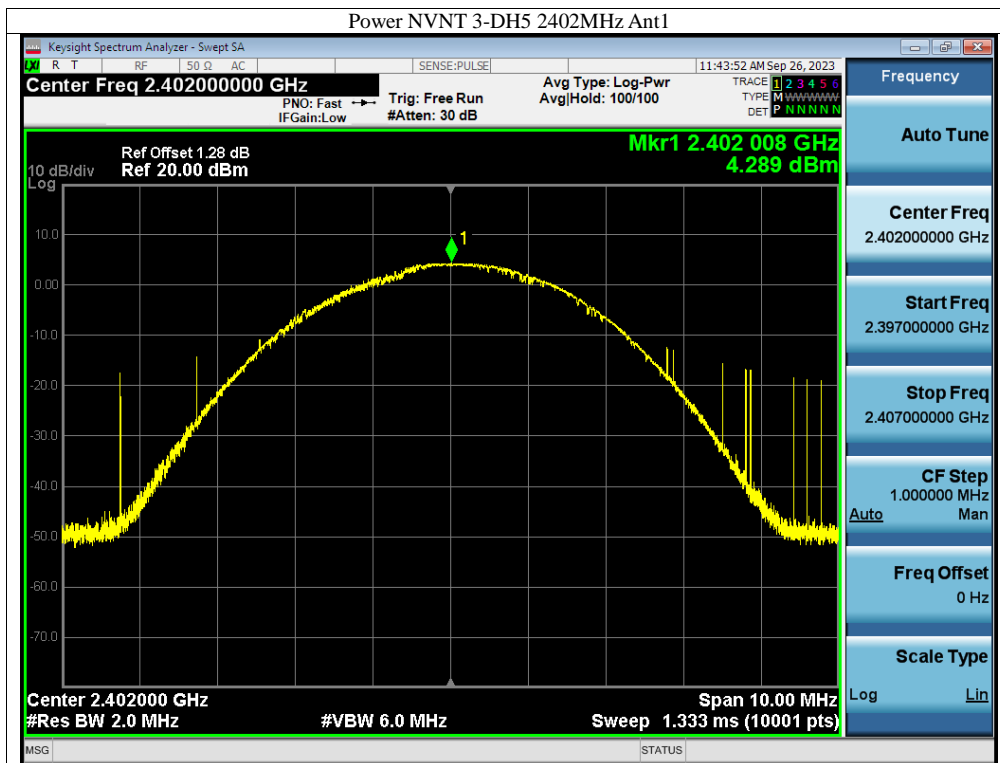
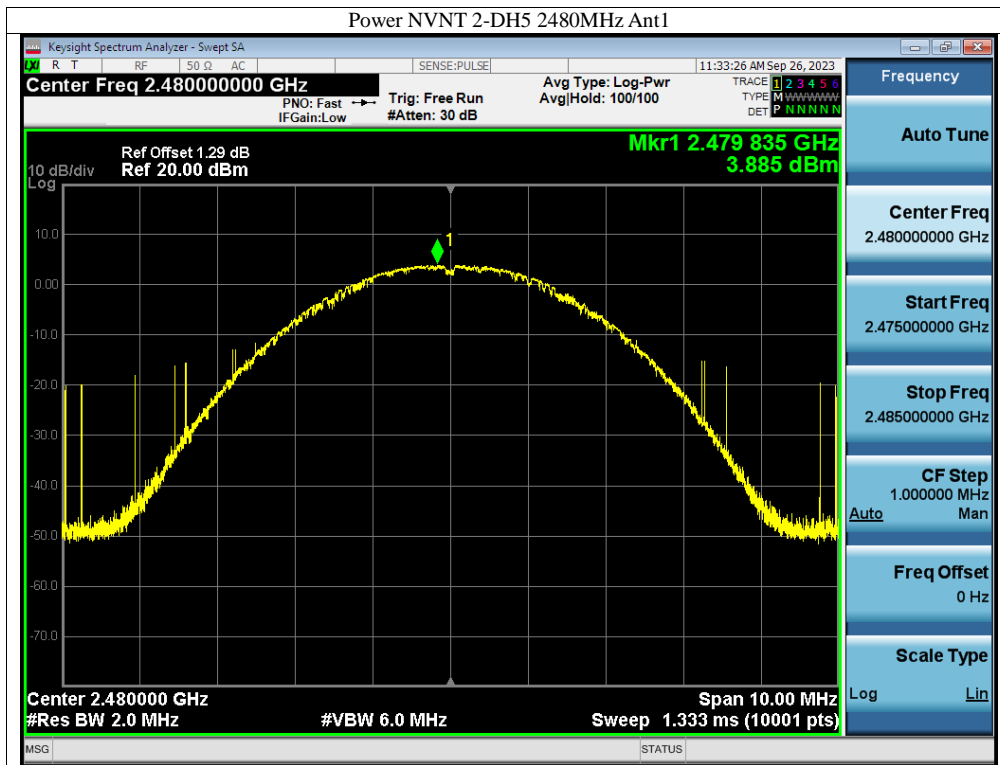

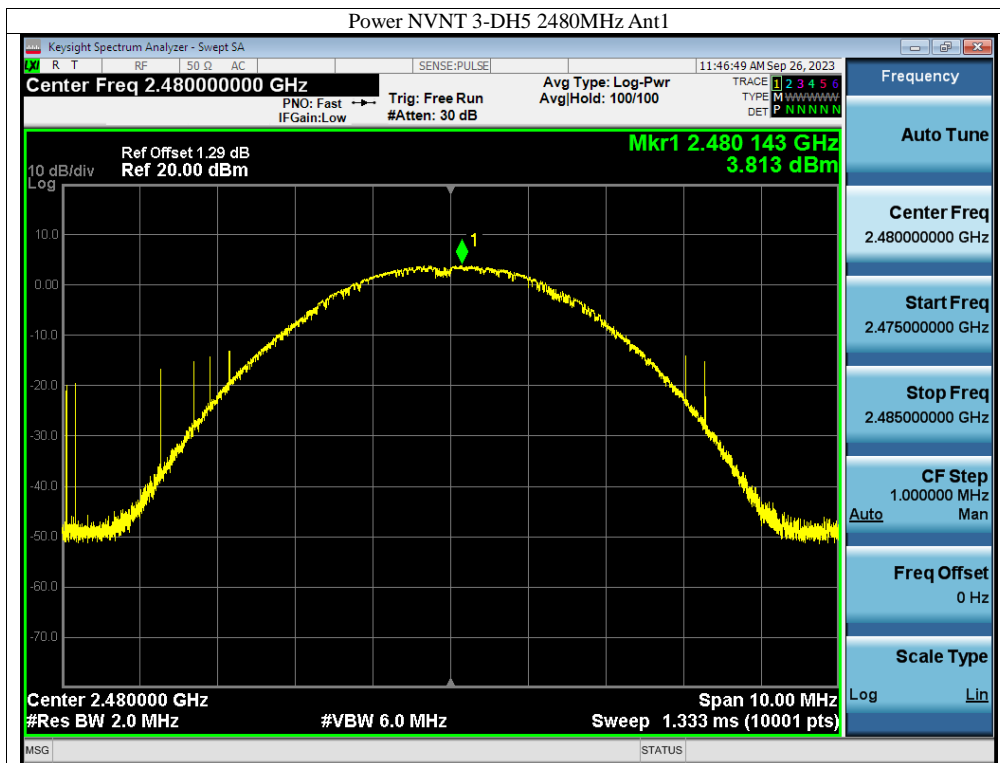
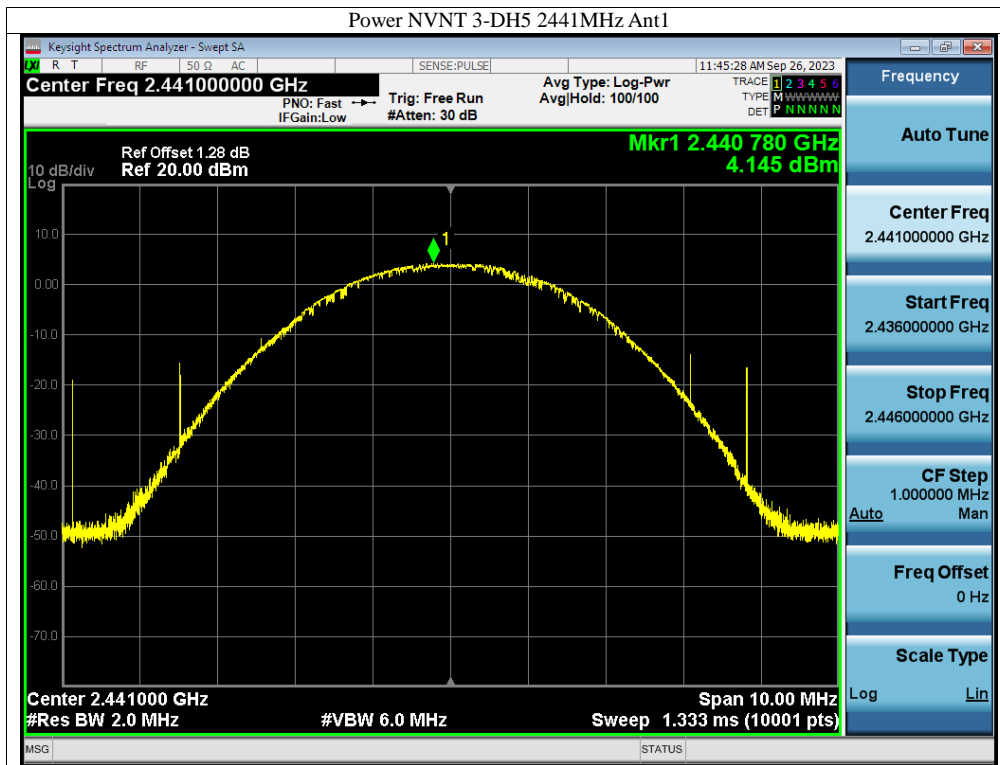

13. Band EDGE test

13.1 Measurement Procedure

For Conducted Test

1. The transmitter output is connected to a spectrum analyzer. The resolution bandwidth is set to 100KHz. The video bandwidth is set to 300KHz.
2. The spectrum from 30MHz to 26 GHz is investigated with the transmitter set to the lowest, middle, and highest channels.

EMI Test Receiver	Setting
Attenuation	Auto
RBW	100KHz
VBW	300KHz
Detector	Peak
Trace	Max hold

For Radiated emission Test

The EUT was placed on a styrofoam table which is 1.5m above ground plane.

The measurement procedure at the band edges was simplified by performing the measurement in just one plot. Both, the in-band-emission and the unwanted emission were encompassed by the span. After trace stabilization, the maximum peak was determined by a peak detector and the value was marked by an appropriate limit line. The second limit line, which is 20dB below the first, marks the limit for the emissions in the unrestricted band. A maximum-peak-detector marks the highest emission in the unrestricted band next to the band edge.

The measurements were performed at the lower end of the 2.4GHz band.

Use the following spectrum analyzer settings:

For Restricted Band, When spectrum scanned above 1GHz setting resolution bandwidth 1MHz, video bandwidth 3MHz:

EMI Test Receiver	Setting
Attenuation	Auto
RBW	1MHz
VBW	3MHz
Detector	Peak
Trace	Max hold

For Non-Restricted Band, When spectrum scanned above 1GHz setting resolution bandwidth 100KHz, video bandwidth 300KHz:

EMI Test Receiver	Setting
Attenuation	Auto
RBW	100KHz
VBW	300KHz
Detector	Peak
Trace	Max hold

13.2 Test SET-UP (Block Diagram of Configuration)

For Conducted Test

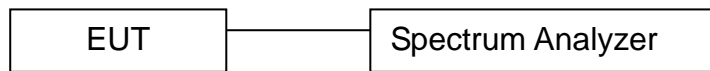

For Radiated emission Test

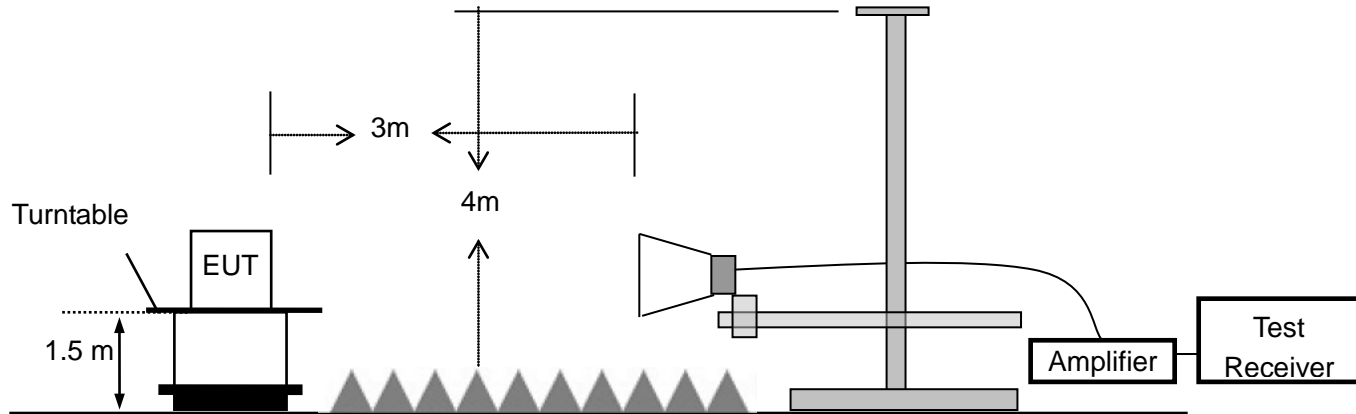

13.3 Measurement Equipment Used:

For Conducted Test

EQUIPMENT TYPE	MFR	MODEL NUMBER	SERIAL NUMBER	CALIBRATED UNTIL
Spectrum Analyzer	KEYSIGHT	N9020A	MY61250185	2023-10-07
RF Test Software	MWRF-test	MTS 8310	N/A	N/A
Radio Frequency control box	MWRF-test	MW200-RFCB	MW220111ANCI	2024-05-10

For Radiated emission Test

Equipment	Manufacturer	Model No.	Serial No.	Calibrated Until
Spectrum Analyzer	Rohde & Schwarz	FSV40	101413	2023-10-07
Low noise Amplifiers	A-INFO	LA1018N4009	J1013130524001	2024-05-10
Horn antenna	A-INFO	LB-10180-SF	J2031090612123	2024-05-14
RF Cable	N/A	ZT26-NJ-NJ-11M	19060401	2024-05-10
RF Cable	N/A	ZT26-NJ-NJ-2.5M	19060402	2024-05-10
3m Semi-anechoic Chamber	chengyu	9m*6m*6m	N/A	2024-11-12
Test Software	Farad	EZ-EMC (Ver.FA-03A2 RE)	N/A	N/A

13.4 Measurement Results:

Refer to attached data chart.

Spectrum Detector: PK Test Date : Sep. 26, 2023
Test By: Zero Temperature : 24 °C
Test Result: PASS Humidity : 53 %

1. Conducted Test

For Hopping Mode:

Mode	Frequency (MHz)	Antenna	Hopping Mode	Max Value (dBc)	Limit (dBc)	Verdict
1-DH5	2402	Ant1	Hopping	-40.11	-20	Pass
1-DH5	2480	Ant1	Hopping	-44.14	-20	Pass
2-DH5	2402	Ant1	Hopping	-45.45	-20	Pass
2-DH5	2480	Ant1	Hopping	-46.38	-20	Pass
3-DH5	2402	Ant1	Hopping	-48.6	-20	Pass
3-DH5	2480	Ant1	Hopping	-48.53	-20	Pass

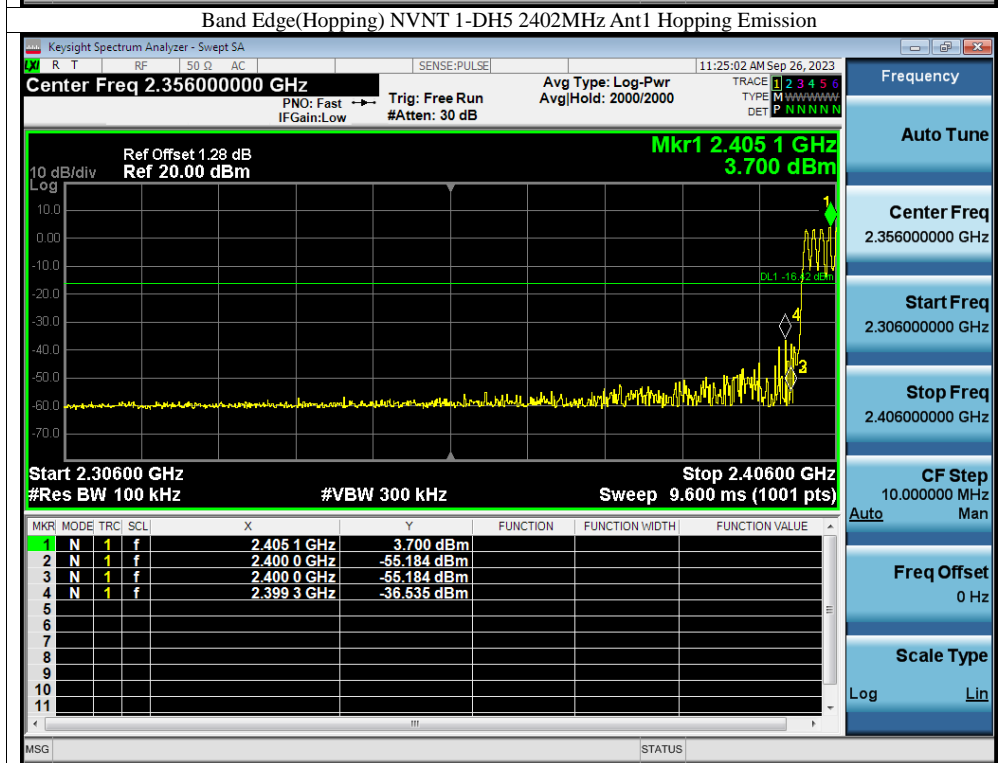
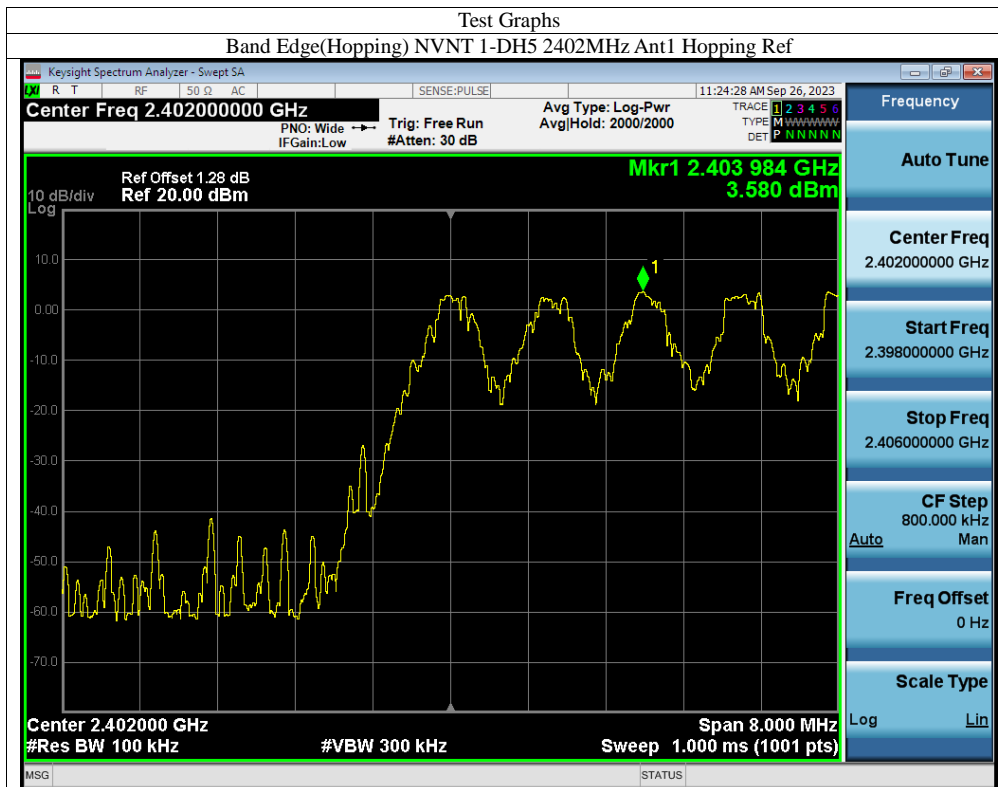

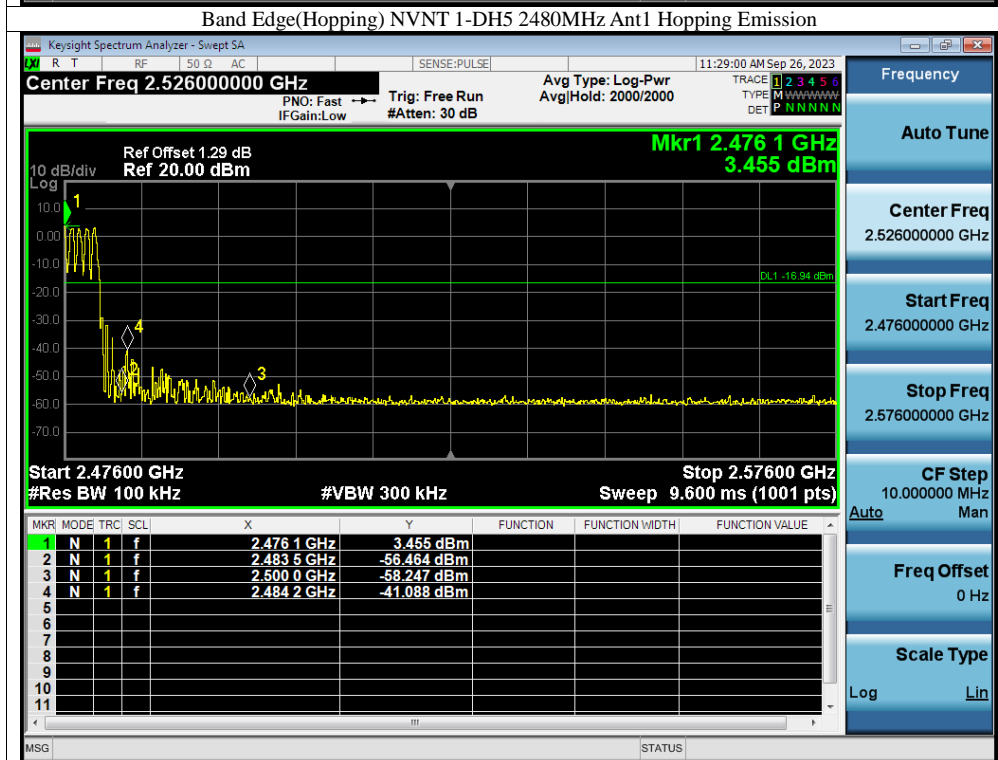
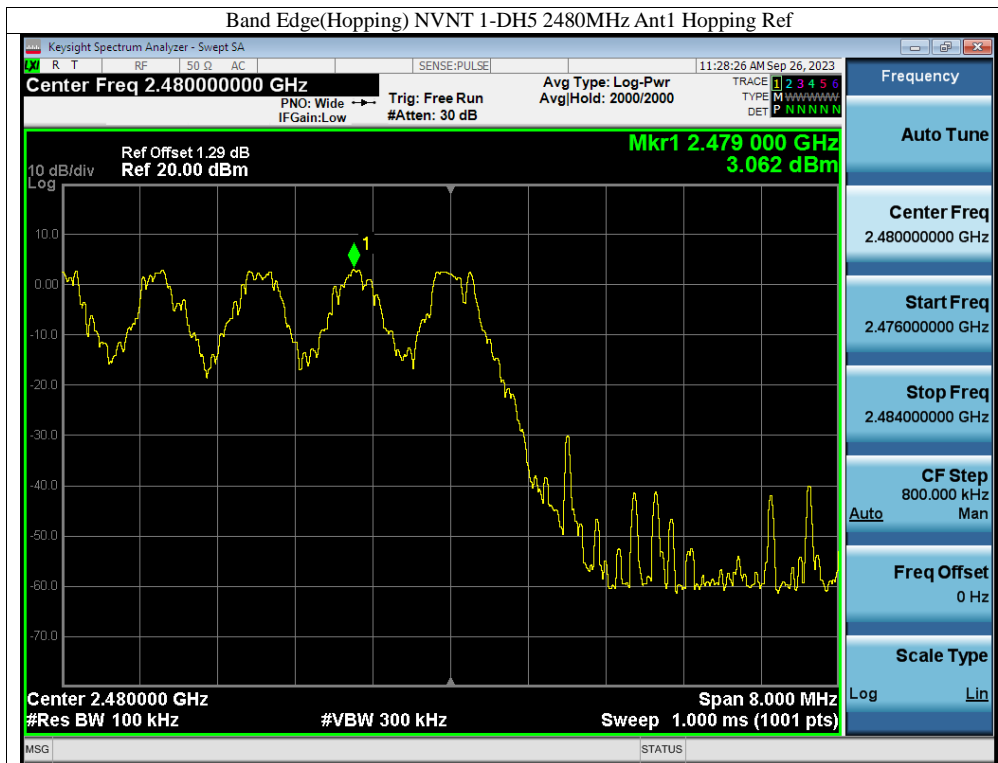

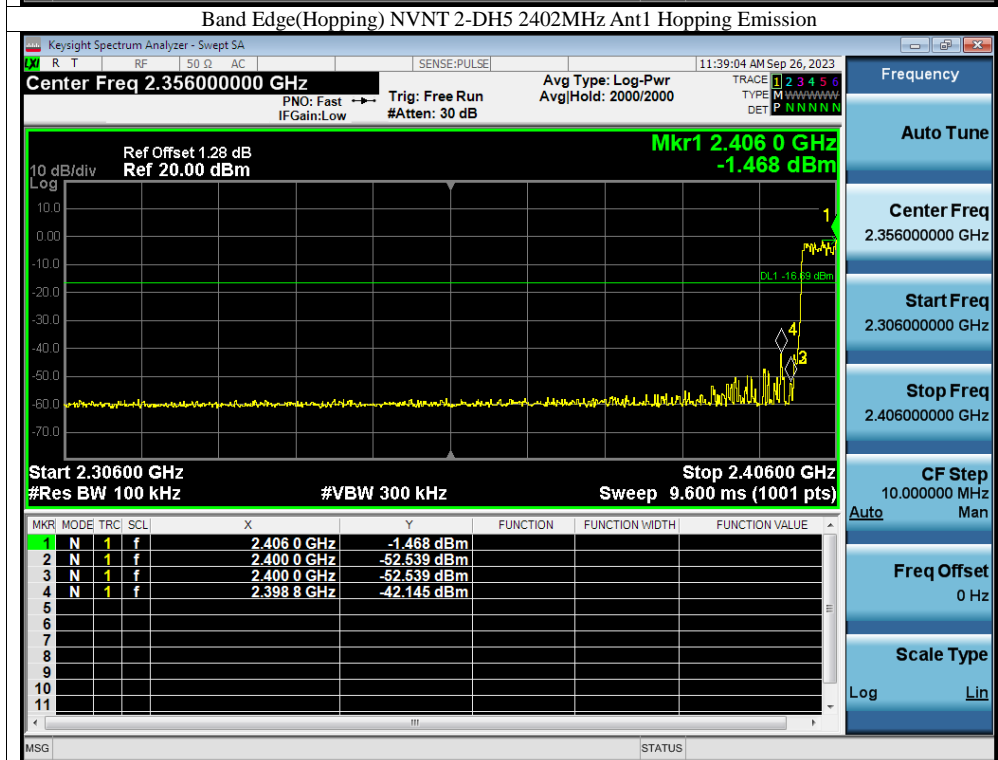
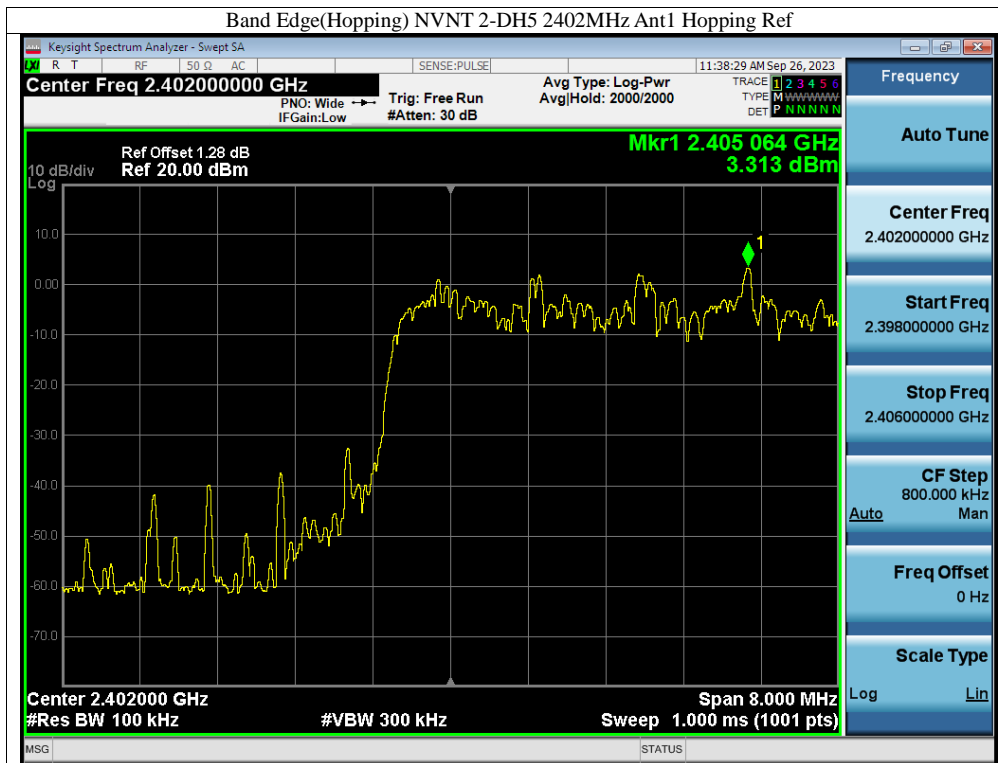

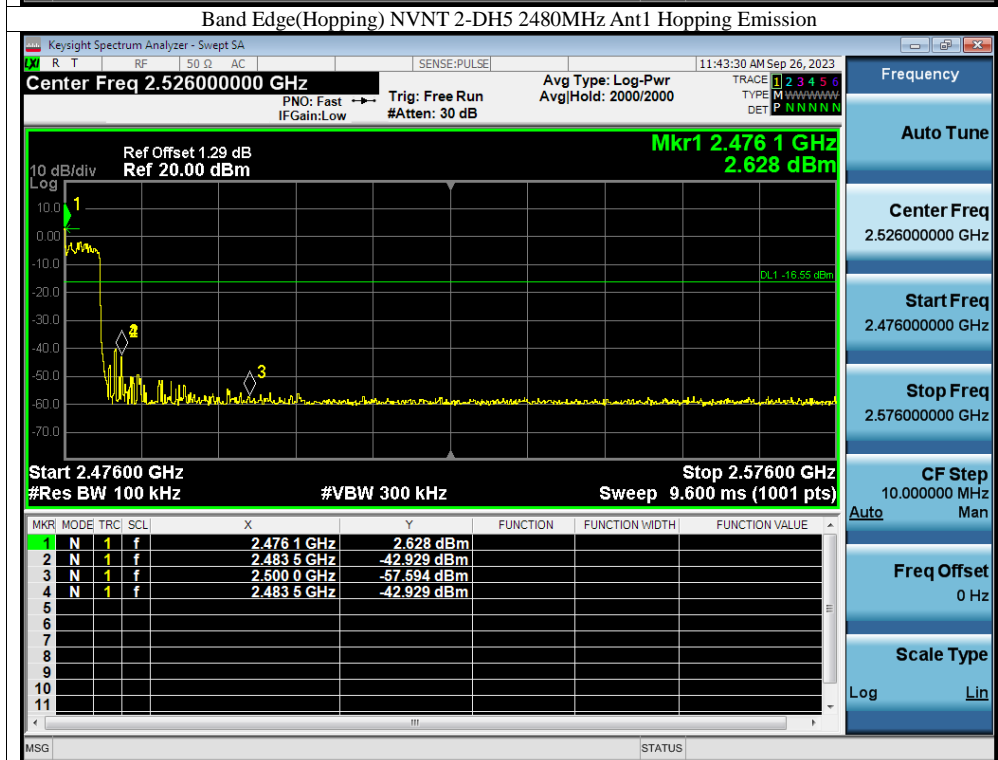
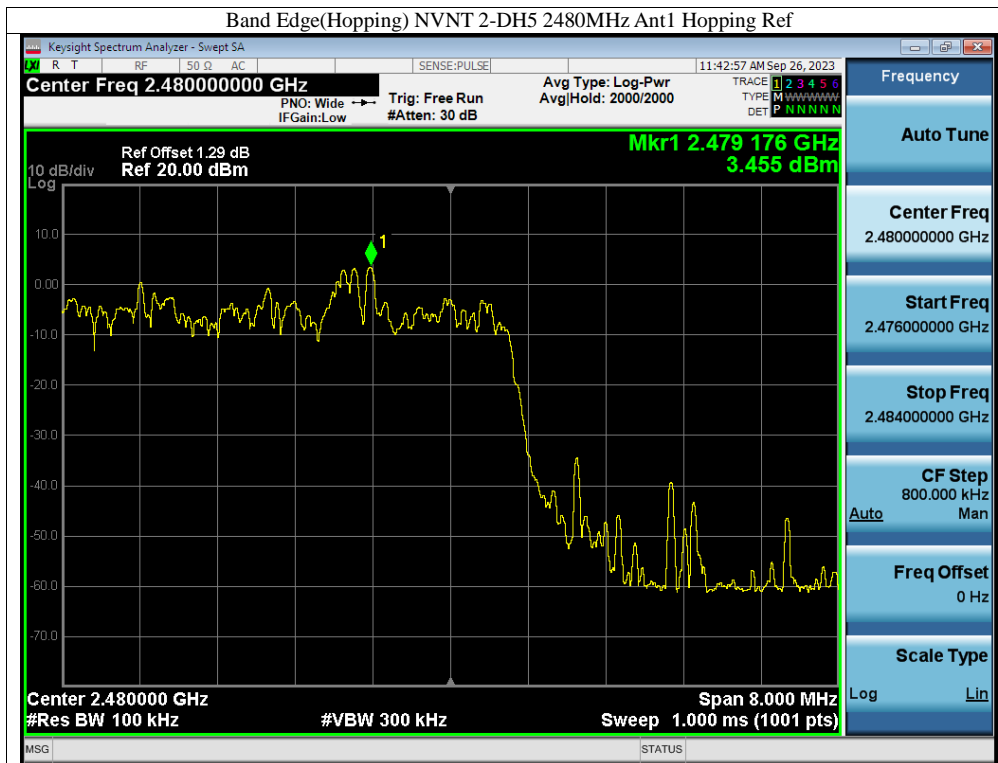

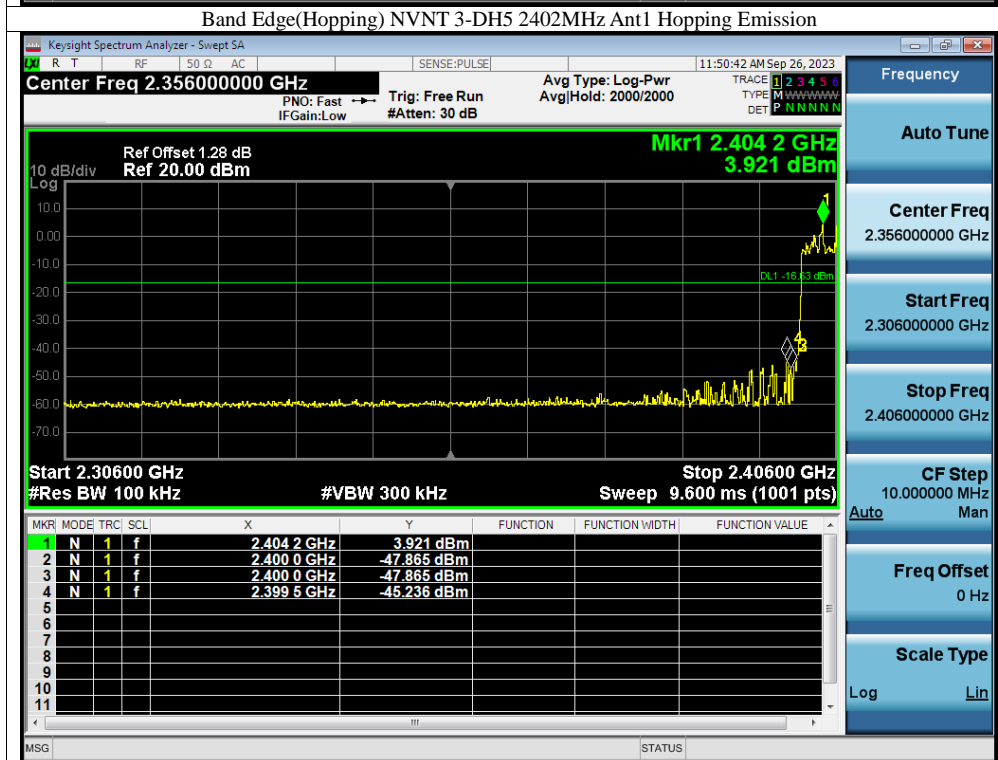
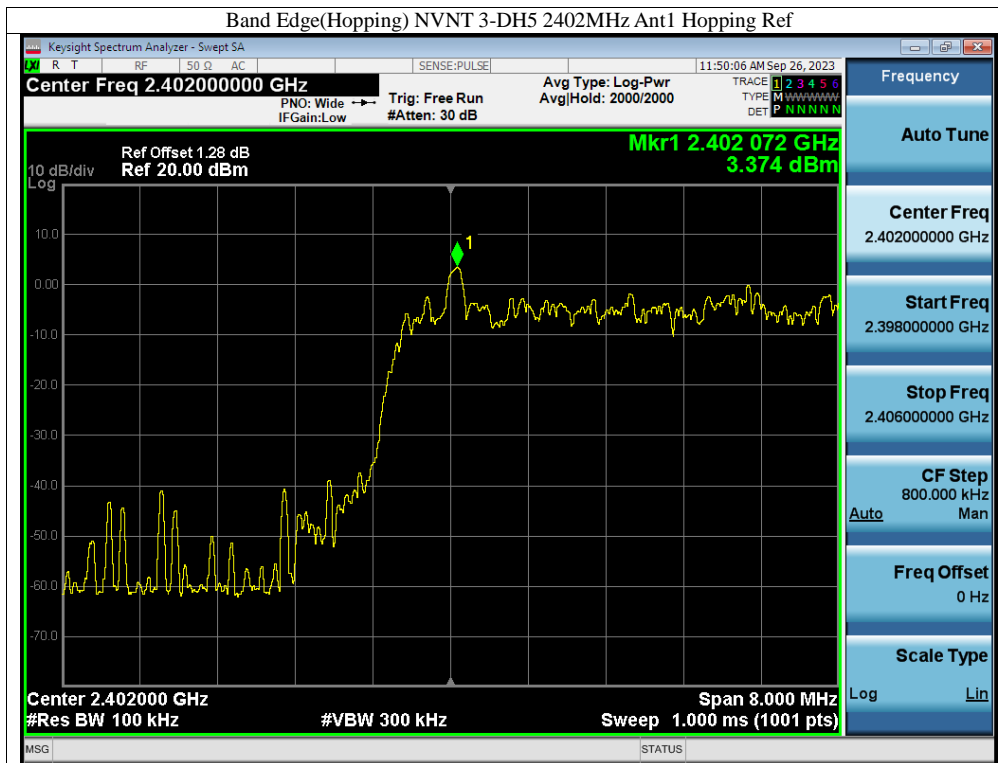

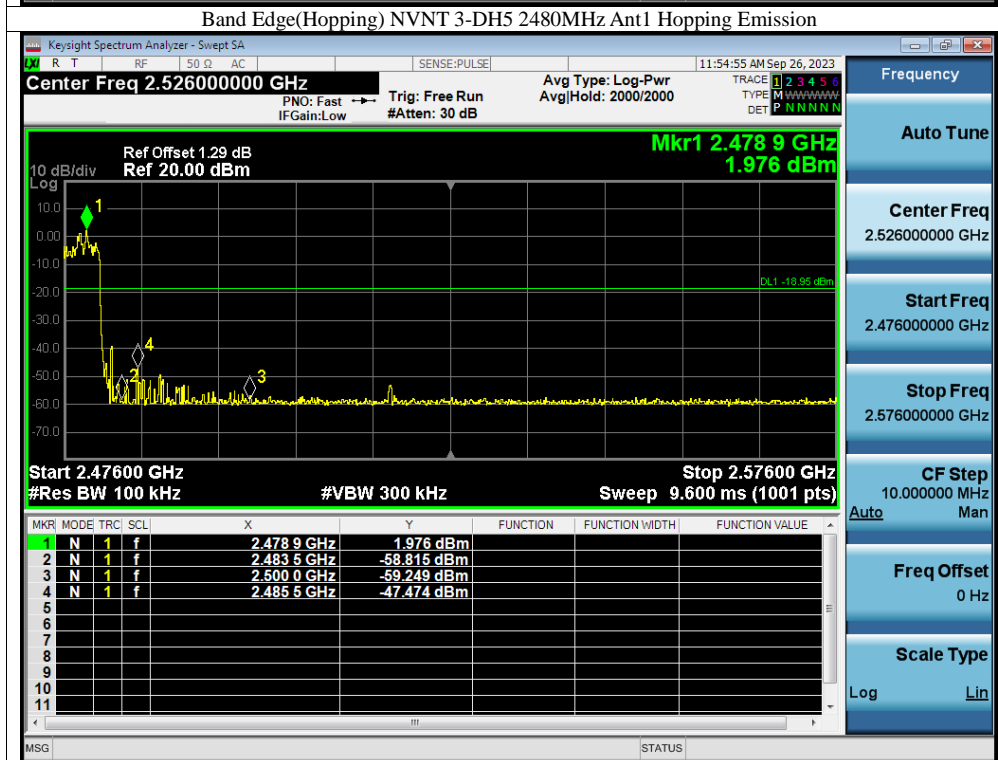
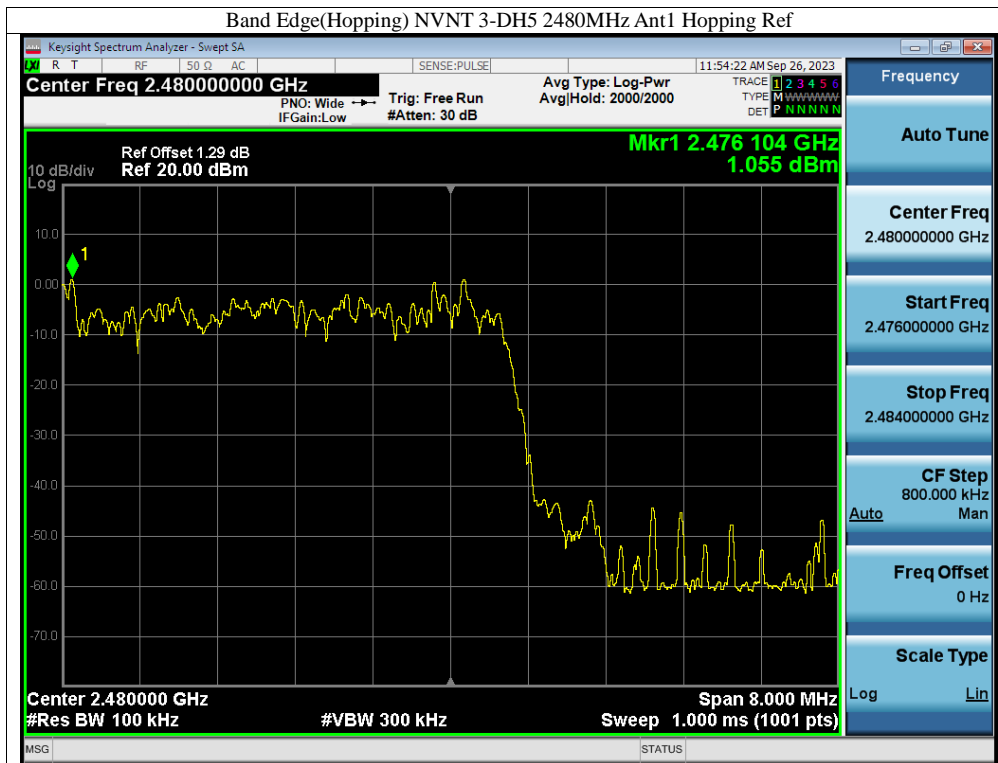

For NO-Hopping Mode:

Mode	Frequency (MHz)	Antenna	Hopping Mode	Max Value (dBc)	Limit (dBc)	Verdict
1-DH5	2402	Ant1	No-Hopping	-43.08	-20	Pass
1-DH5	2480	Ant1	No-Hopping	-43.51	-20	Pass
2-DH5	2402	Ant1	No-Hopping	-40.72	-20	Pass
2-DH5	2480	Ant1	No-Hopping	-40.57	-20	Pass
3-DH5	2402	Ant1	No-Hopping	-44.81	-20	Pass
3-DH5	2480	Ant1	No-Hopping	-44.85	-20	Pass

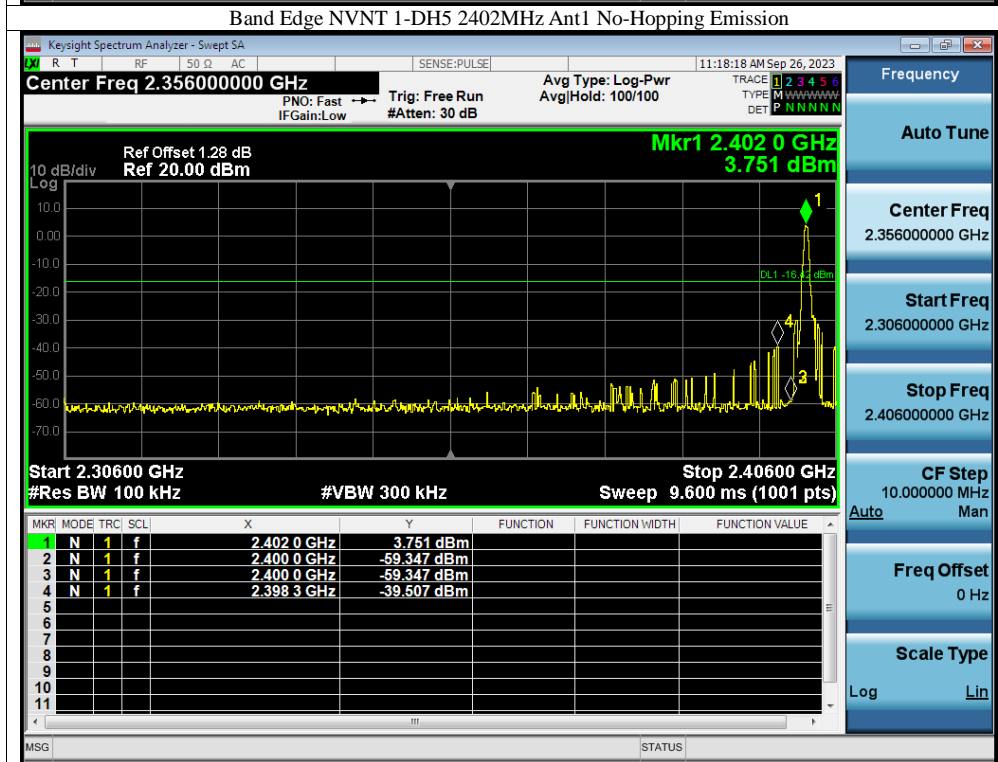
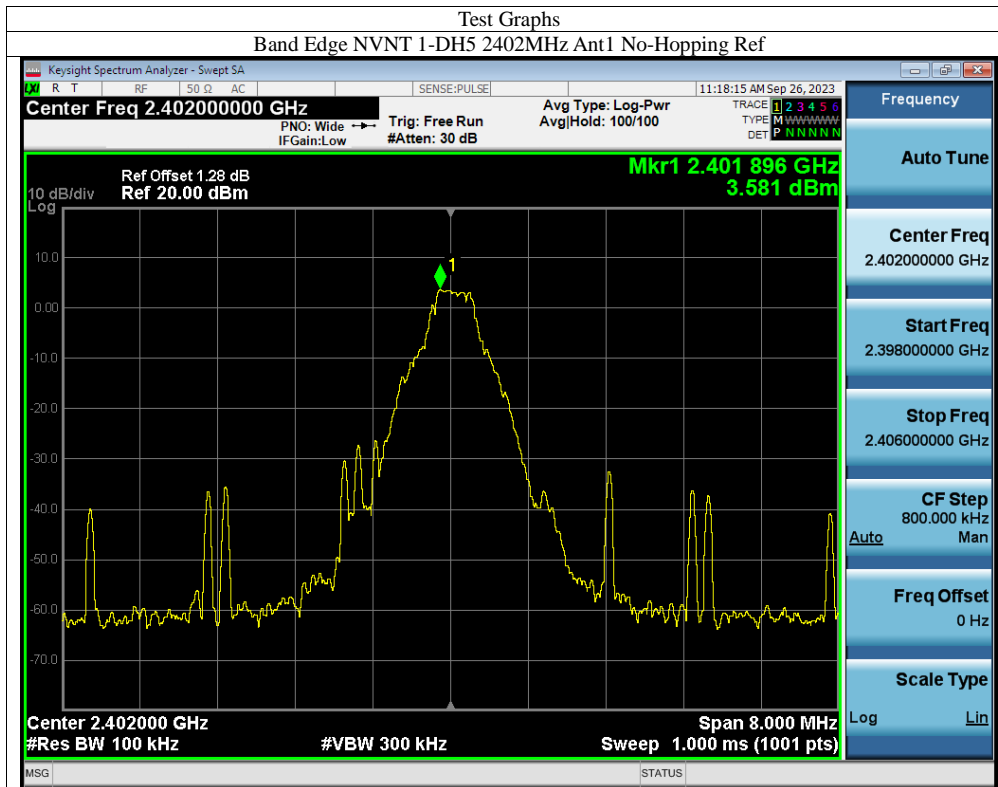

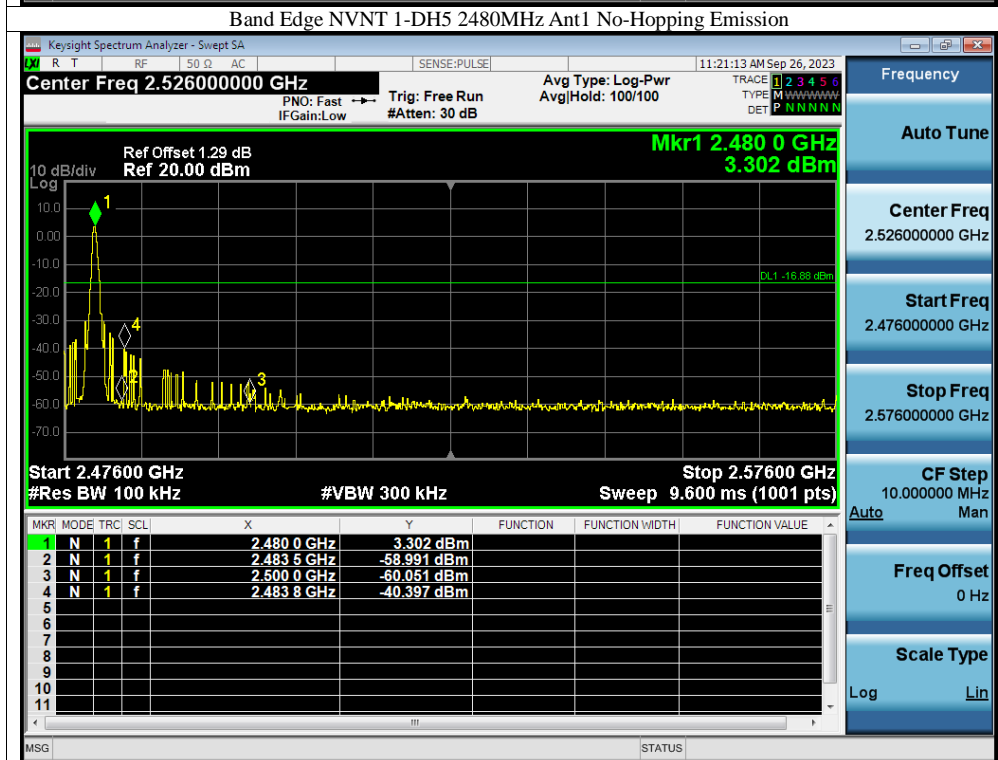
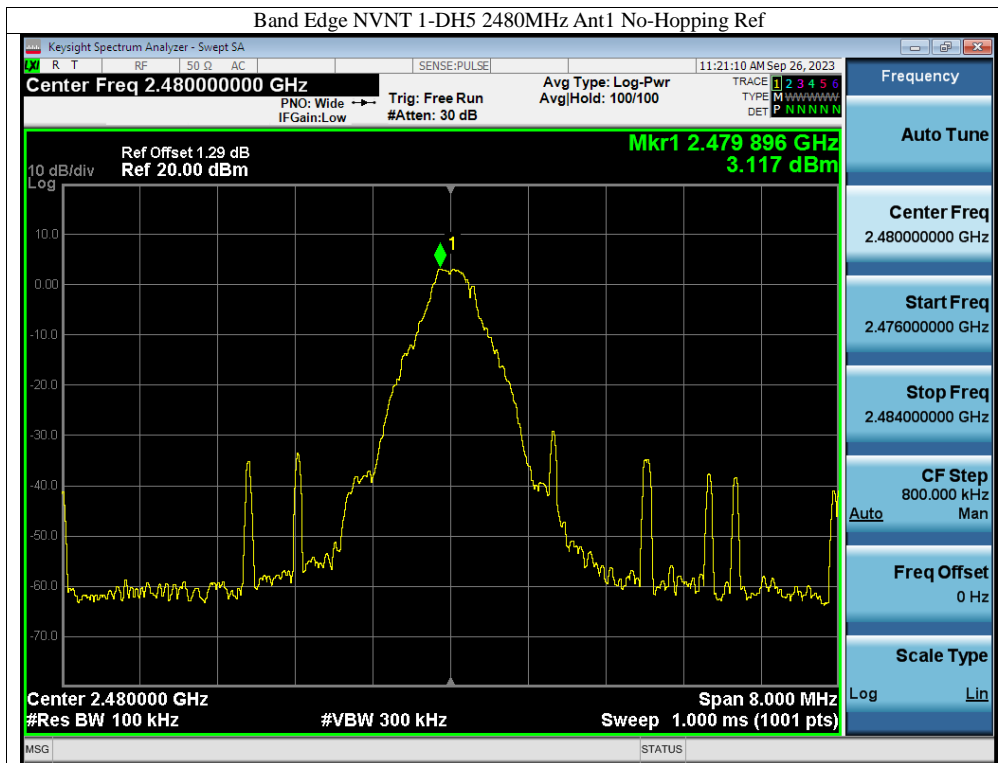

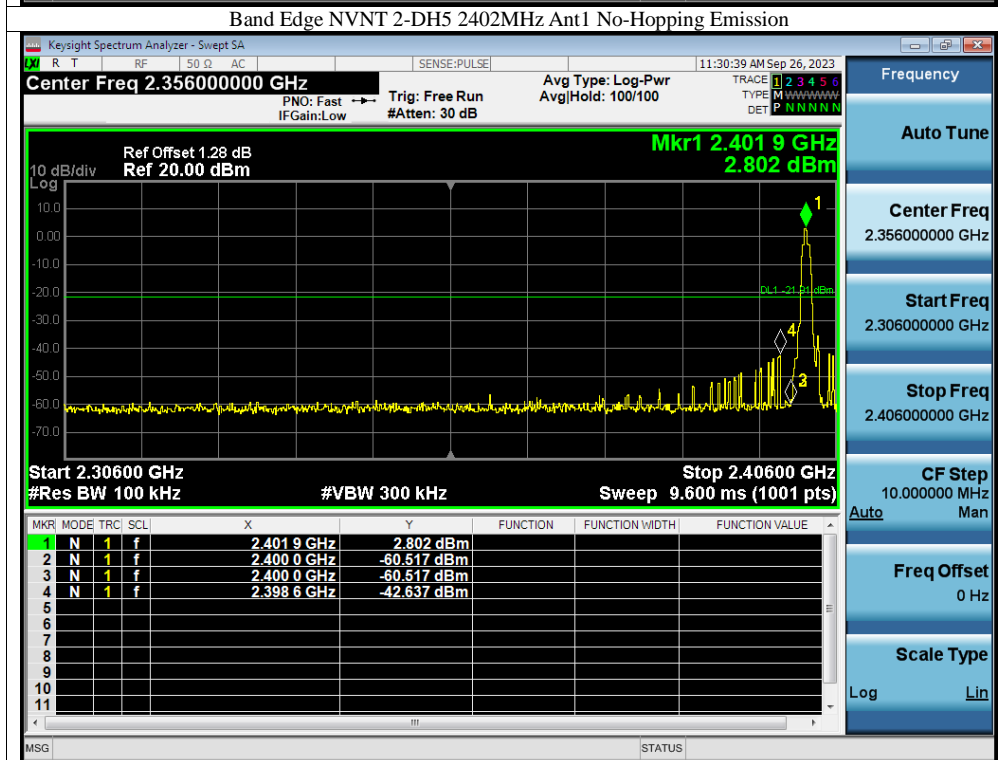
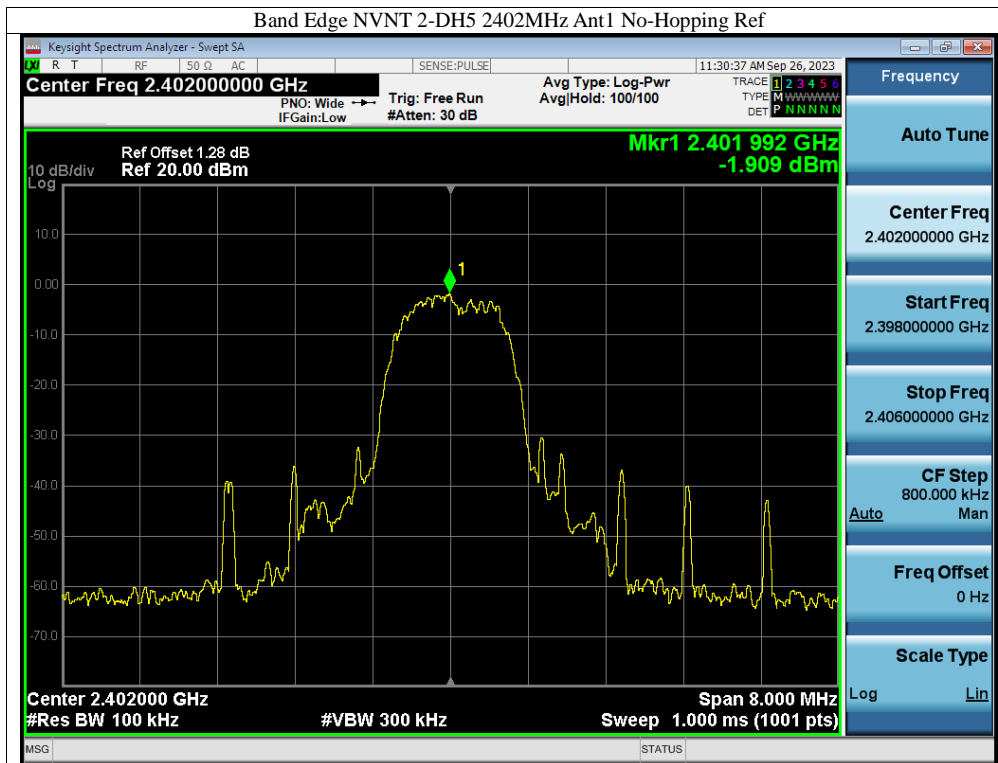

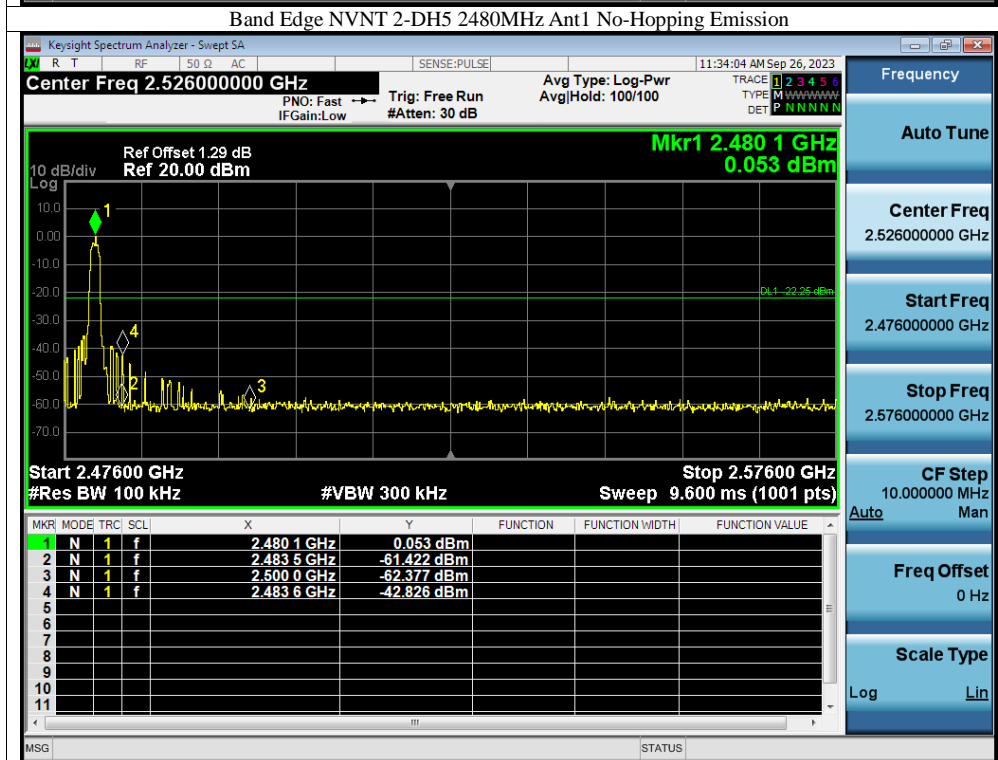
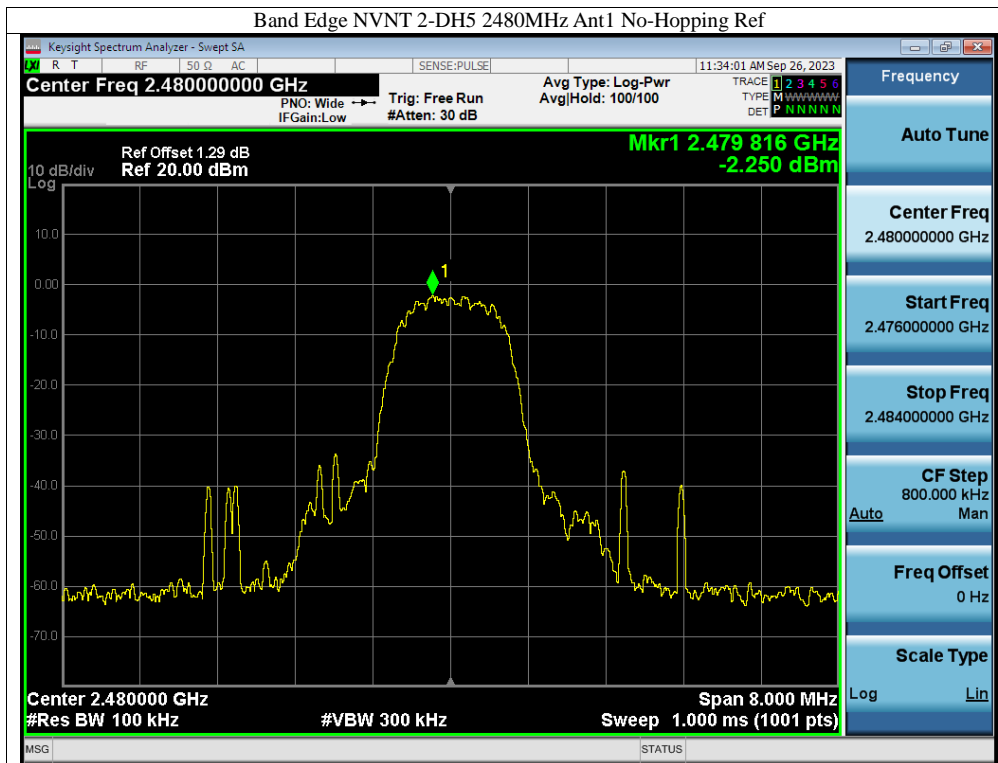

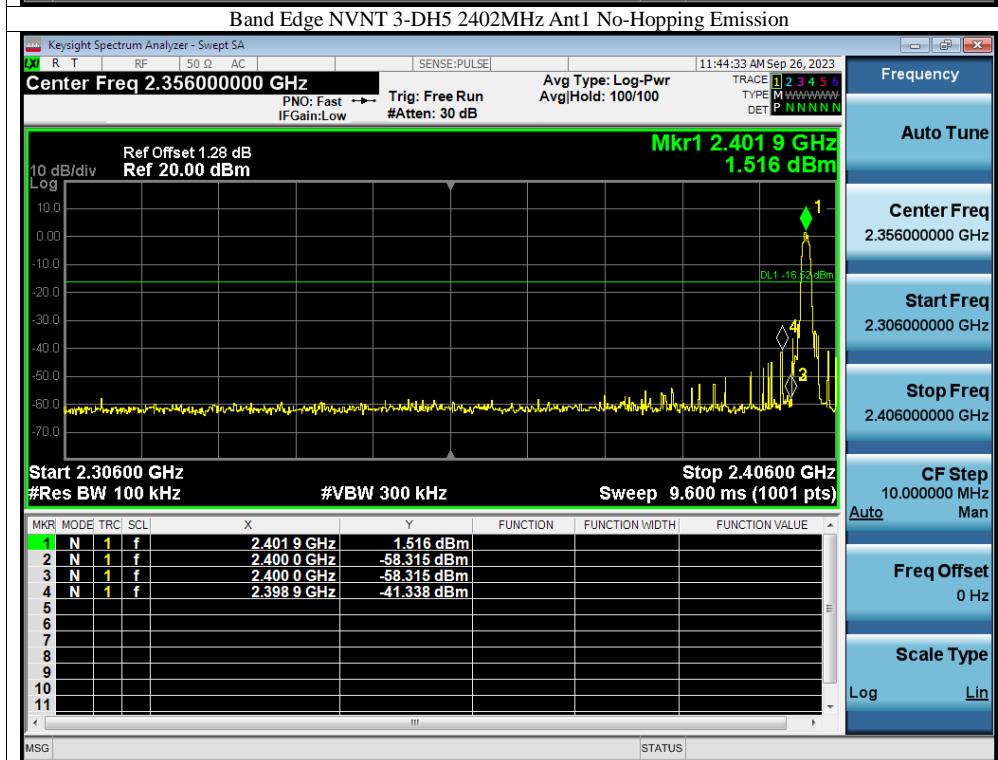
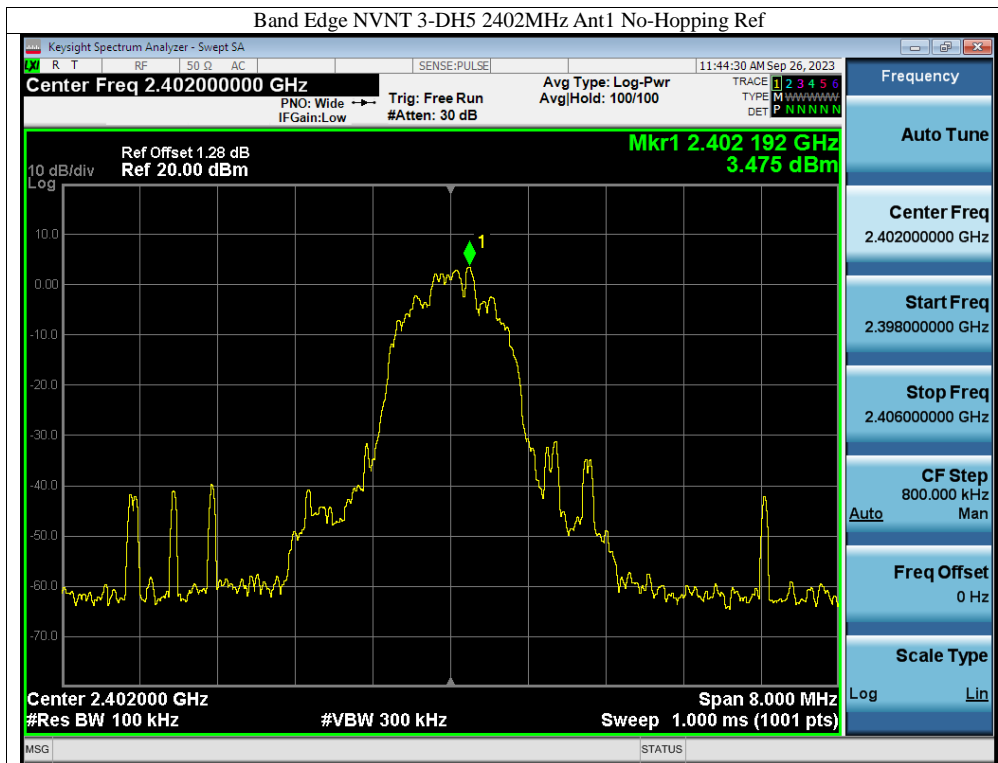

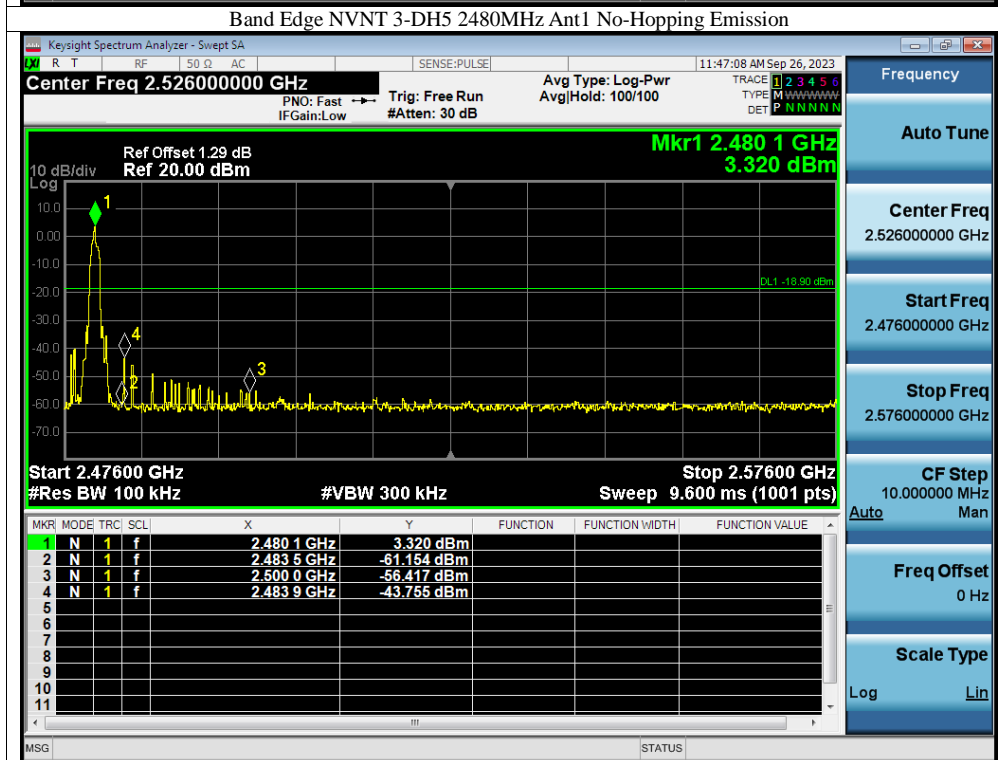
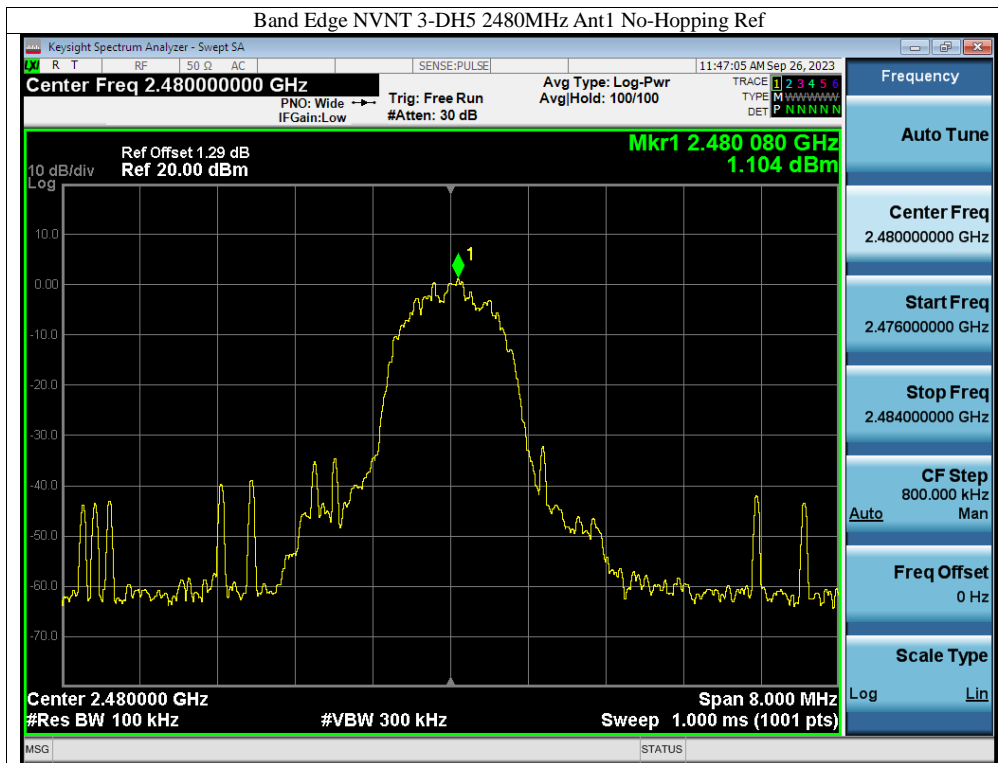

2. Radiated Test
For Non-Hopping Mode:

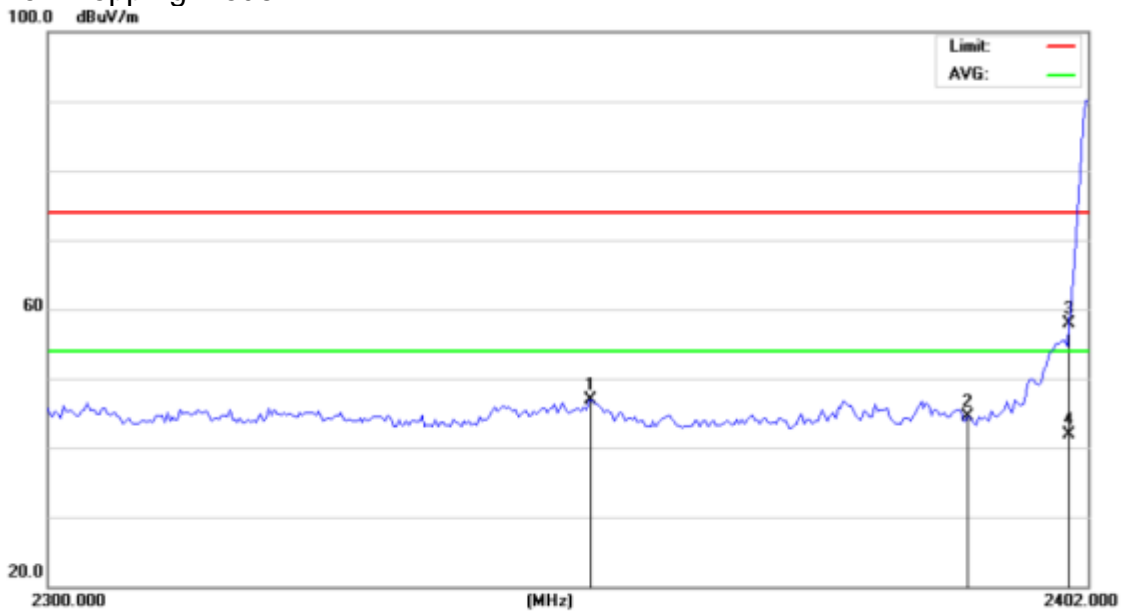

Site ANCI 843.3 Polarization: **Horizontal** Temperature: 26.5(C)
Limit: FCC Part 15 C 3m Above1G(Peak) Humidity: 60.6 %

Mode: TX2402

Note:

No.	Mk.	Freq.	Reading Level	Correct Factor	Measurement	Limit	Over	Antenna Height	Table Degree	
		MHz	dBuV	dB	dBuV/m	dB/m	dB	cm	degree	Comment
1		2352.743	52.05	-5.07	46.98	74.00	-27.02			peak
2		2390.000	49.24	-4.82	44.42	74.00	-29.58			peak
3		2400.000	62.70	-4.75	57.95	74.00	-16.05			peak
4	*	2400.000	46.58	-4.75	41.83	54.00	-12.17			AVG

*:Maximum data x:Over limit !:over margin

(Reference Only)

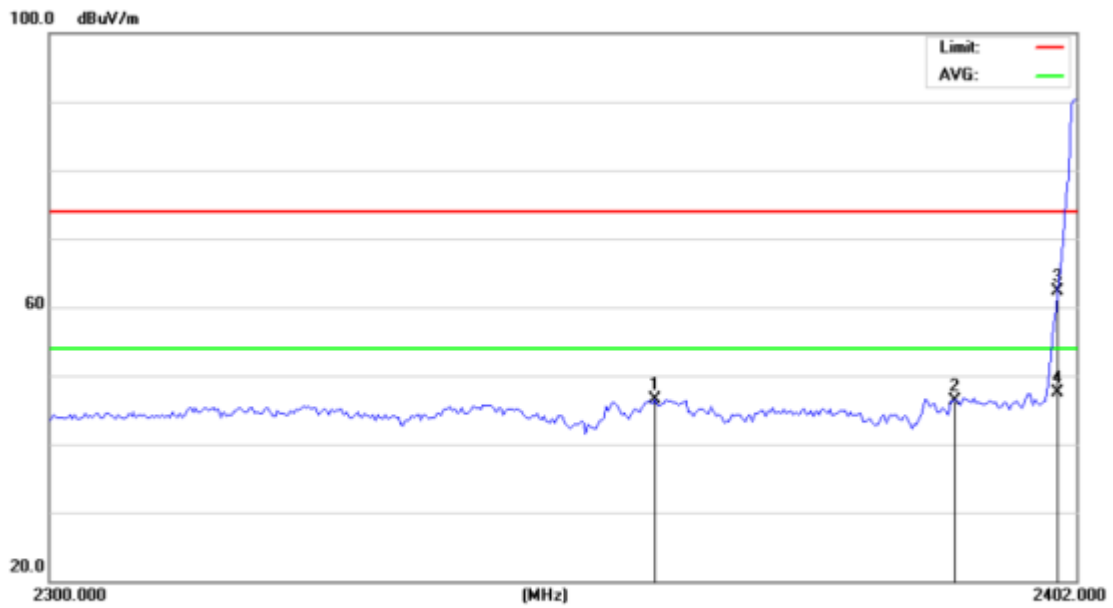

Site ANCI 843.3 Polarization: **Vertical** Temperature: 26.5(C)
 Limit: FCC Part 15 C 3m Above1G(Peak) Humidity: 60.6 %
 Mode: TX2402
 Note:

No.	Mk.	Freq. MHz	Reading Level dBuV	Correct Factor dB	Measure- ment dBuV/m	Limit dB/m	Over dB	Antenna Height cm	Table Degree degree	Comment
1		2359.644	51.48	-5.03	46.45	74.00	-27.55			peak
2		2390.000	51.18	-4.82	46.36	74.00	-27.64			peak
3		2400.000	67.00	-4.75	62.25	74.00	-11.75			peak
4	*	2400.000	52.32	-4.75	47.57	54.00	-6.43			AVG

*:Maximum data x:Over limit !:over margin <Reference Only

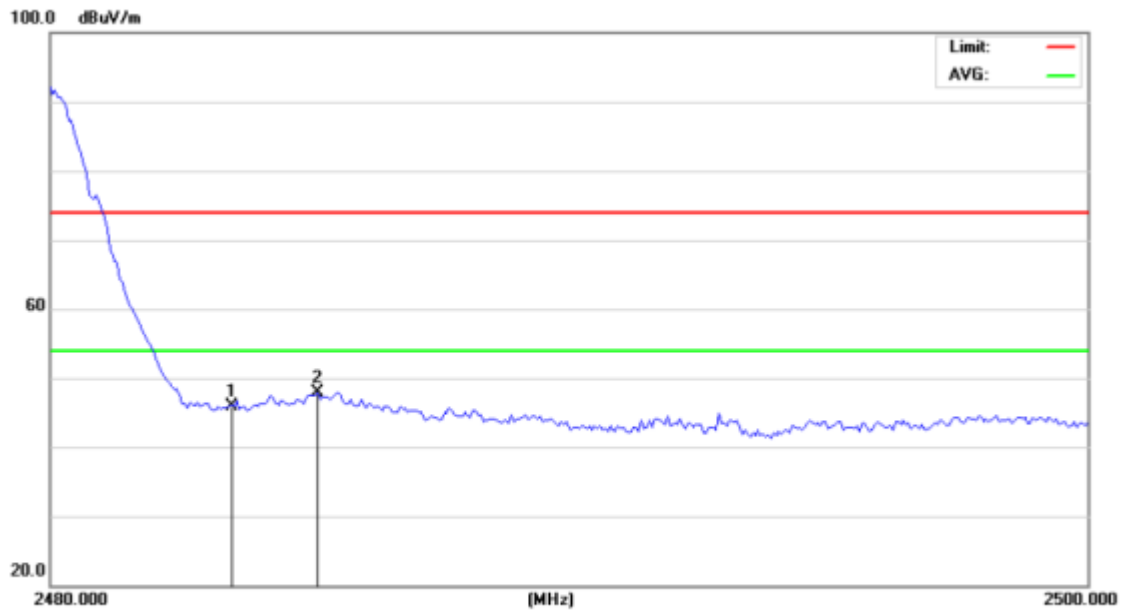

Site ANCI 843.3 Polarization: *Horizontal* Temperature: 26.5(C)
 Limit: FCC Part 15 C 3m Above1G(Peak) Humidity: 60.6 %
 Mode: TX2480
 Note:

No.	Mk.	Freq.	Reading Level	Correct Factor	Measurement	Limit	Over	Antenna Height	Table Degree	
		MHz	dBuV	dB	dBuV/m	dB/m	dB	cm	degree	Comment
1		2483.500	50.05	-4.19	45.86	74.00	-28.14	peak		
2	*	2485.135	52.01	-4.18	47.83	74.00	-26.17	peak		

*:Maximum data x:Over limit !:over margin (Reference Only)

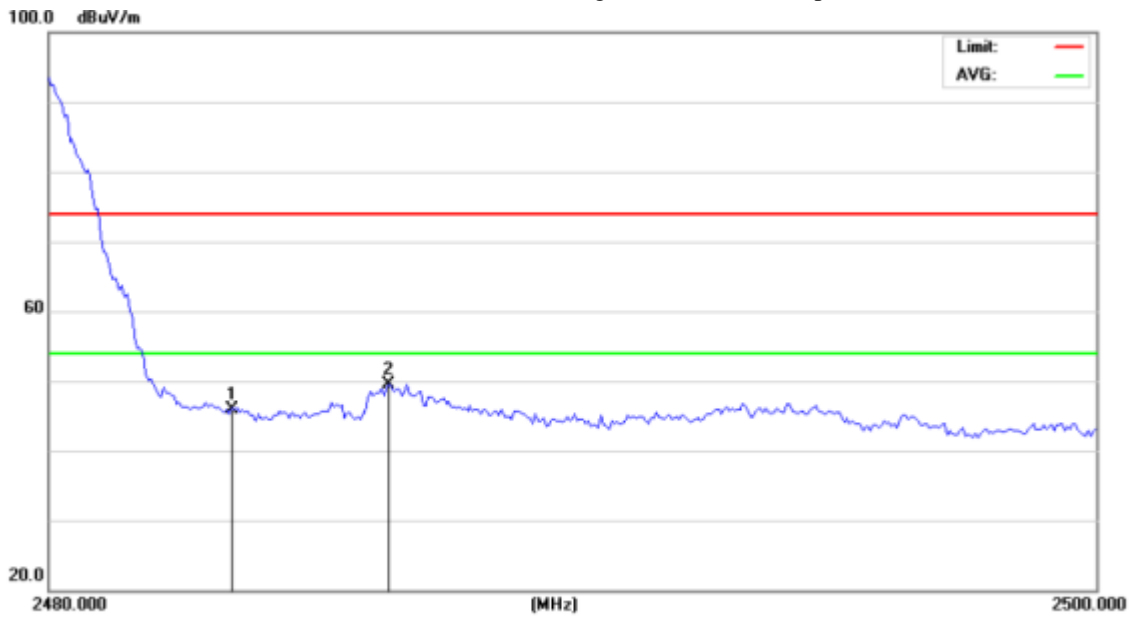

Site ANCI 843.3 Polarization: *Vertical* Temperature: 26.5(C)
 Limit: FCC Part 15 C 3m Above1G(Peak) Humidity: 60.6 %
 Mode: TX2480
 Note:

No.	Mk.	Freq.	Reading Level	Correct Factor	Measurement	Limit	Over	Antenna Height	Table Degree
		MHz	dBuV	dB	dBuV/m	dB/m	dB	cm	degree
1		2483.500	50.14	-4.19	45.95	74.00	-28.05	peak	
2	*	2486.482	53.64	-4.18	49.46	74.00	-24.54	peak	

*:Maximum data x:Over limit !:over margin <Reference Only

For Hopping Mode:

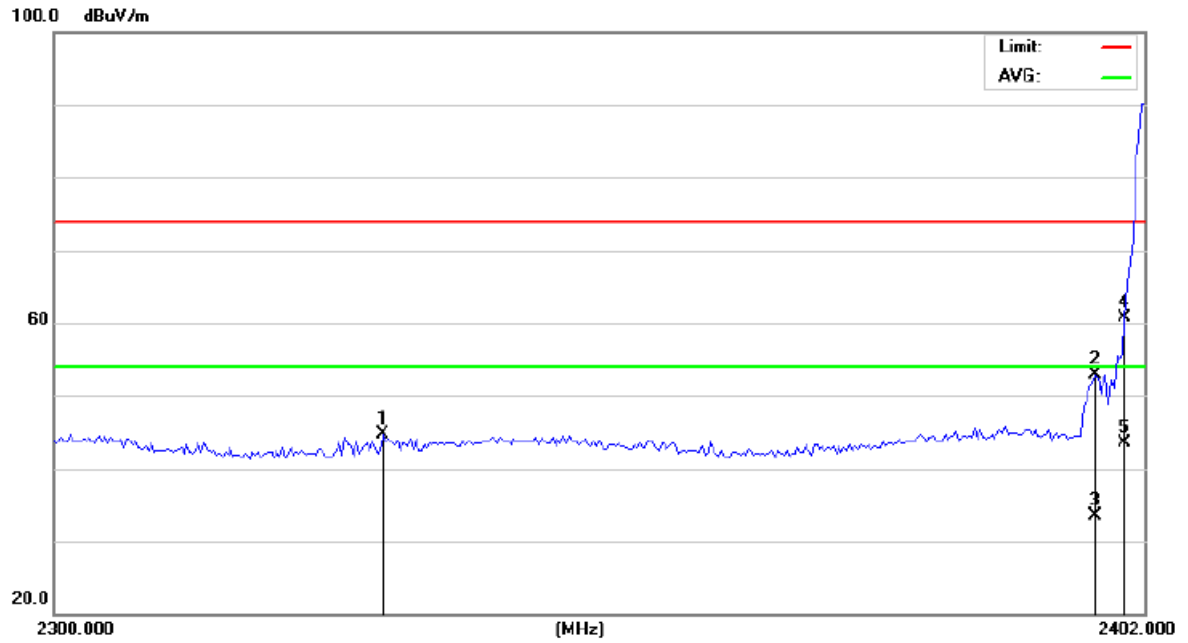

Site 843

Polarization: *Horizontal*

Temperature: 26.5(C)

Limit: FCC Part 15 C 3m Above1G(Peak)

Humidity: 60.6 %

Mode: Hopping

Note:

No.	Mk.	Freq.	Reading Level	Correct Factor	Measurement	Limit	Over	Antenna Height	Table Degree	
		MHz	dBuV	dB	dBuV/m	dB/m	dB	cm	degree	Comment
1		2330.389	49.89	-5.21	44.68	74.00	-29.32			peak
2		2397.314	57.63	-4.77	52.86	74.00	-21.14			peak
3		2397.314	38.25	-4.77	33.48	54.00	-20.52			AVG
4		2400.000	65.44	-4.75	60.69	74.00	-13.31			peak
5	*	2400.000	48.25	-4.75	43.50	54.00	-10.50			AVG

*:Maximum data x:Over limit !:over margin

(Reference Only)

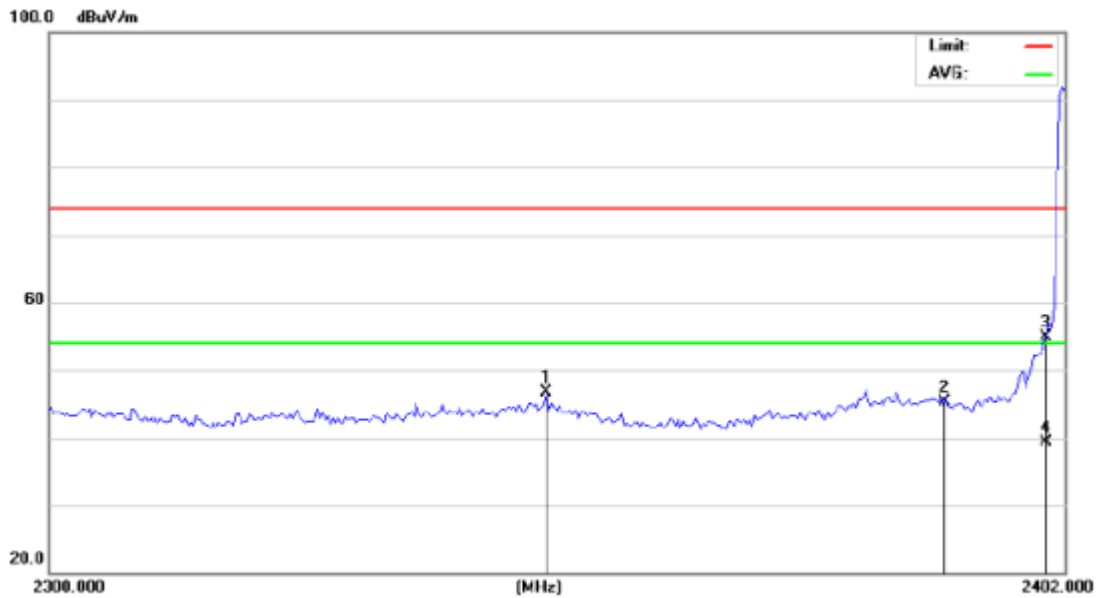

Site ANCI 843.3

Polarization: *Vertical*

Temperature: 26.5(C)

Limit: FCC Part 15 C 3m Above1G(Peak)

Humidity: 60.6 %

Mode: Hopping

Note:

No.	Mk.	Freq.	Reading Level	Correct Factor	Measurement	Limit	Over	Antenna Height	Table Degree	
		MHz	dBuV	dB	dBuV/m	dB/m	dB	cm	degree	Comment
1		2349.427	51.74	-5.09	46.65	74.00	-27.35			peak
2		2390.000	50.07	-4.82	45.25	74.00	-28.75			peak
3		2400.000	59.75	-4.75	55.00	74.00	-19.00			peak
4	*	2400.000	44.05	-4.75	39.30	54.00	-14.70			AVG

*:Maximum data x:Over limit !:over margin

(Reference Only)

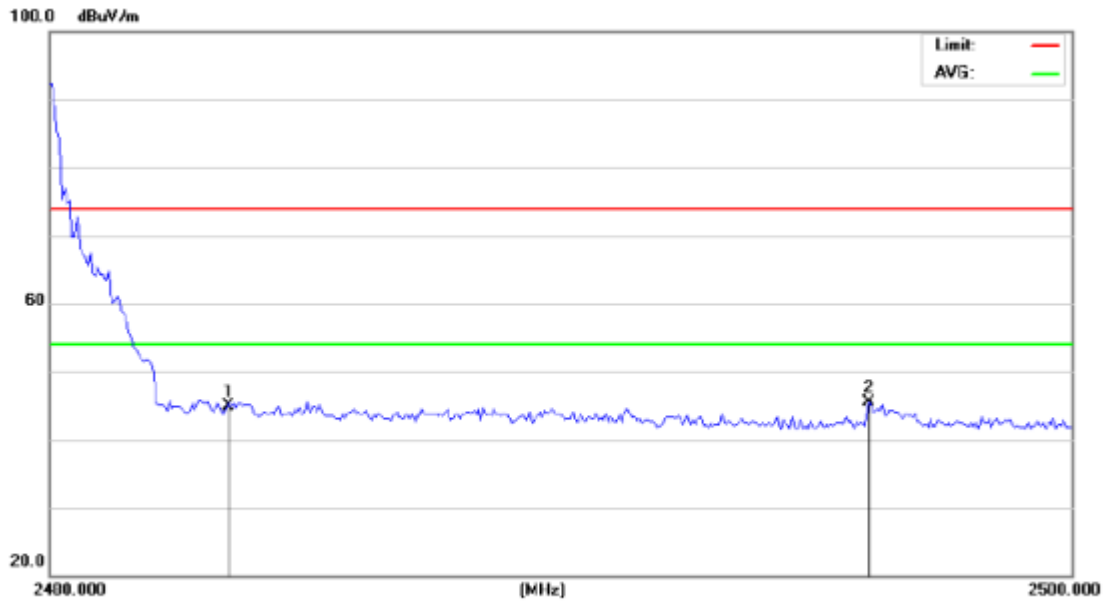

Site ANCI 843.3 Polarization: *Horizontal* Temperature: 26.5(C)
 Limit: FCC Part 15 C 3m Above1G(Peak) Humidity: 60.6 %
 Mode: Hopping
 Note:

No.	Mk.	Freq.	Reading Level	Correct Factor	Measurement	Limit	Over	Antenna Height	Table Degree	
		MHz	dBuV	dB	dBuV/m	dB/m	dB	cm	degree	Comment
1		2483.500	49.12	-4.19	44.93	74.00	-29.07			peak
2	*	2496.037	49.54	-4.11	45.43	74.00	-28.57			peak

*:Maximum data x:Over limit !:over margin (Reference Only)

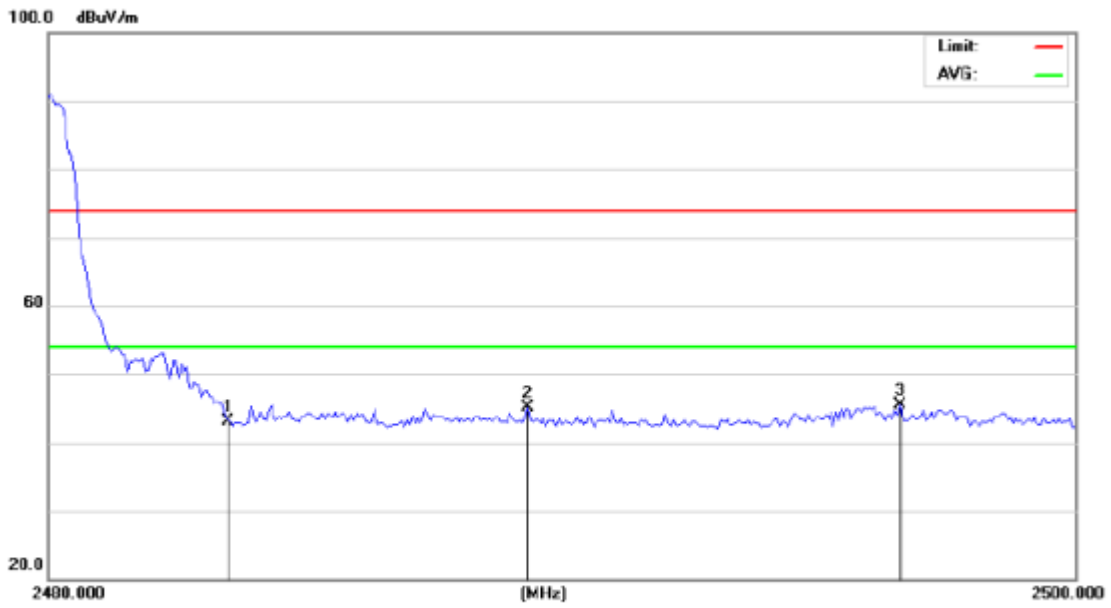

Site ANCI 843.3

Polarization: *Vertical*

Temperature: 26.5(C)

Limit: FCC Part 15 C 3m Above1G(Peak)

Humidity: 60.6 %

Mode: Hopping

Note:

No.	Mk.	Freq. MHz	Reading Level dBuV	Correct Factor dB	Measure- ment dBuV/m	Limit dB/m	Over dB	Detector	Antenna Height cm	Table Degree	Comment
1		2483.500	47.22	-4.19	43.03	74.00	-30.97	peak			
2		2489.330	49.32	-4.16	45.16	74.00	-28.84	peak			
3	*	2496.589	49.68	-4.11	45.57	74.00	-28.43	peak			

*:Maximum data x:Over limit !:over margin

<Reference Only

14. Antenna Application

14.1 Antenna requirement

The EUT'S antenna is met the requirement of FCC part 15C section 15.203 and 15.247.

FCC part 15C section 15.247 requirements:

Systems operating in the 2402-2480MHz band that are used exclusively for fixed, point-to-point operations may employ transmitting antennas with directional gain greater than 6dBi provided the maximum peak output power of the intentional radiator is reduced by 1dB for every 3dB that the directional gain of the antenna exceeds 6dBi.

14.2 Result

The EUT's antenna, permanent attached antenna, used a PCB Antenna and integrated on PCB, The antenna's gain is 3.14dBi and meets the requirement.

APPENDIX (Photos of EUT)

External Photos







Internal Photos



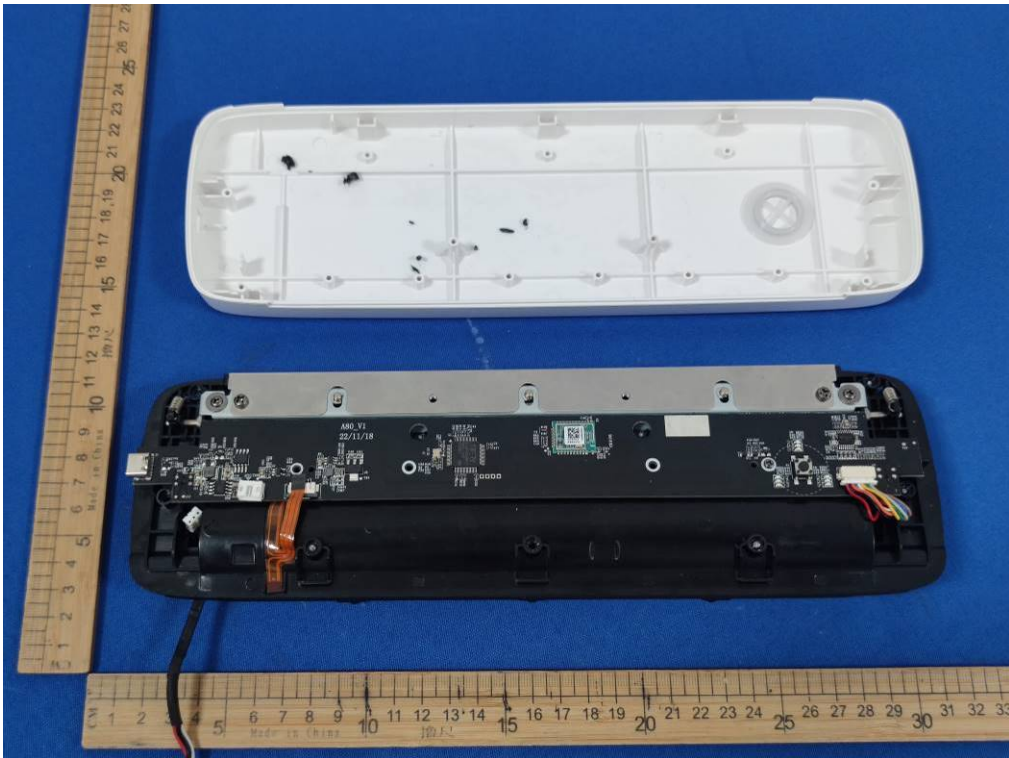

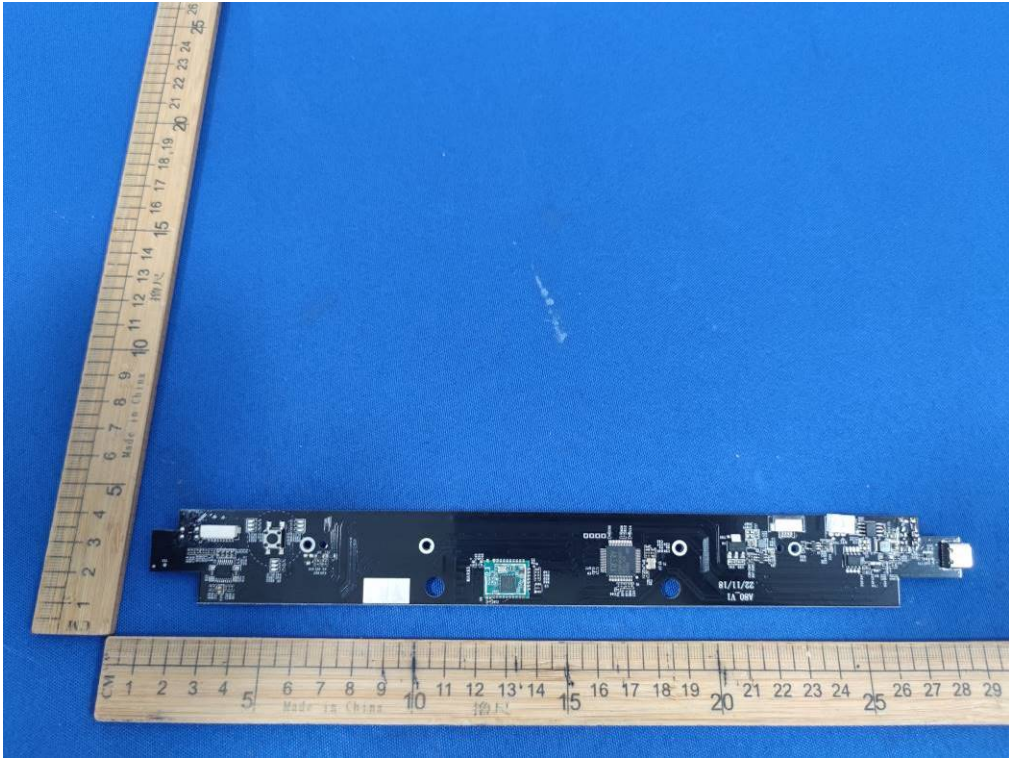



--- End of Report ---