

深圳市一线通线缆有限公司

地址：深圳市宝安区沙井街道万丰98工业城21栋

天线规格承认书

Antenna Specification for Approval

客户名称

CustomerName: 深圳市魔样科技有限公司_____

产品名称:

ProductName: 2.4G天线 全长25mm红色

客户型号:

ProductName: _____

产品料号:

Part NO.: C10- 35- 2.5

制表:

WriteBy: 庄杰彬

日期:

IssuedDate: 2021- 10-08

客 户:

工程 <i>R& D Dept</i>	采购 <i>Business Dept</i>	承认 <i>Approved By</i>

一线通

研发 <i>R& D Dept</i>	工程 <i>Engineer Dept</i>	审核 <i>Approval</i>
庄彩虹	庄杰彬	庄杰彬

Ø0.6 19p

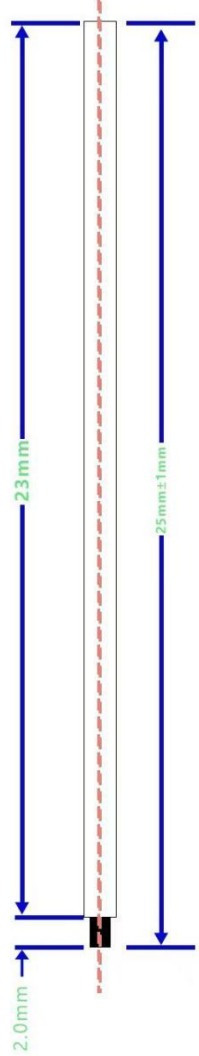

2.Environmental treatment

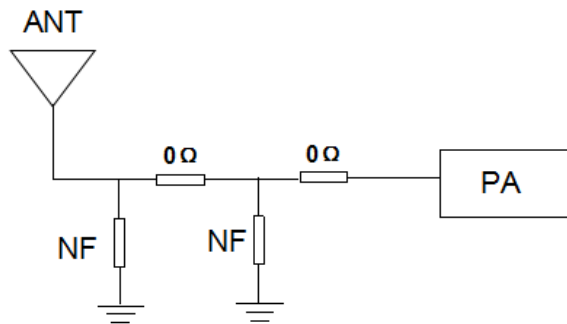

Frequency ID	1	2	3	4	5	6	7	8	9	10	11
Frequency (MHz)	2400.0	2410.0	2420.0	2430.0	2440.0	2450.0	2460.0	2470.0	2480.0	2490.0	2500.0
Efficiency (dBi)	-6.25	-6.32	-6.21	-5.71	-6.04	-6.53	-6.16	-6.19	-6.22	-6.01	-5.88
Gain (dBi)	-1.12	-1.28	-0.99	-0.40	-0.85	-1.21	-0.92	-1.14	-1.32	-1.25	-1.19
Efficiency (%)	23.70	23.31	23.96	26.84	24.89	22.22	24.22	24.06	23.87	25.05	25.84

Efficiency & Gain

Radiation Pattern:

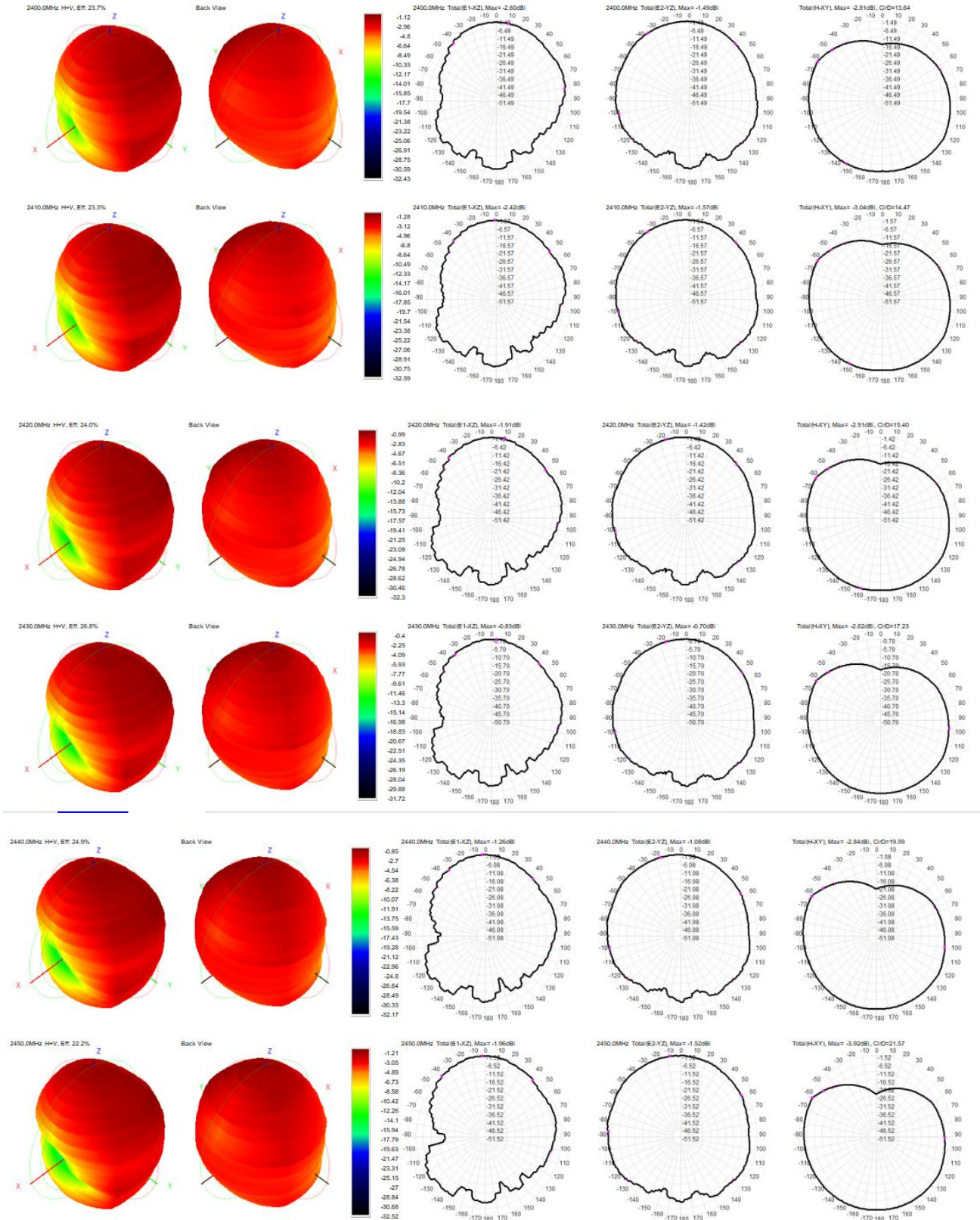

2460.0MHz HHV, Eff: 24.2%

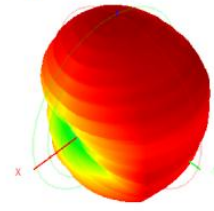

Back View

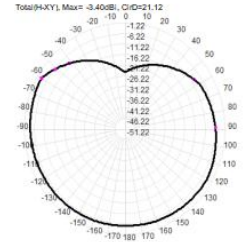
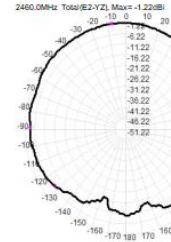
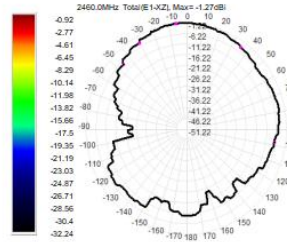
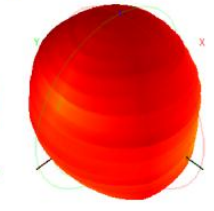

2470.0MHz HHV, Eff: 24.1%

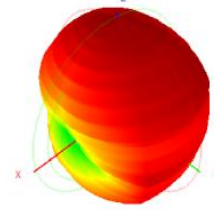

Back View

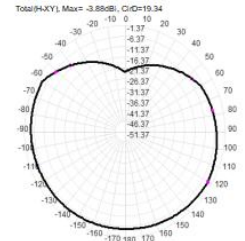
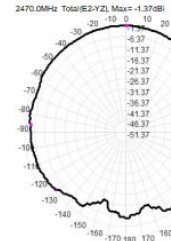
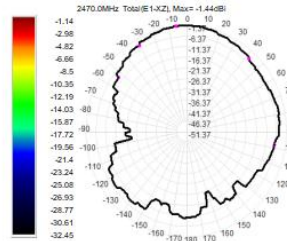
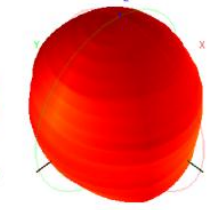

2480.0MHz HHV, Eff: 23.9%

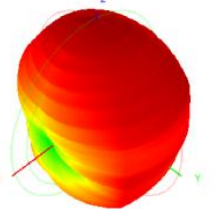

Back View

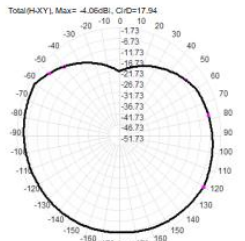
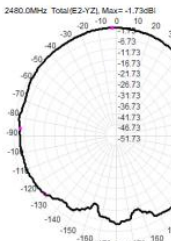
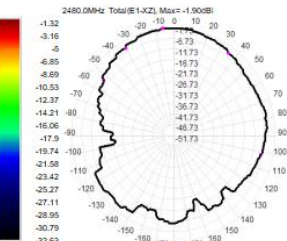
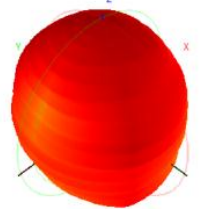

2490.0MHz HHV, Eff: 25.0%

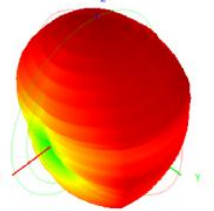

Back View

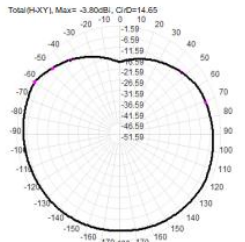
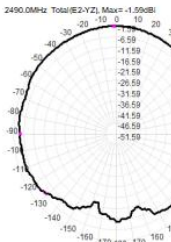
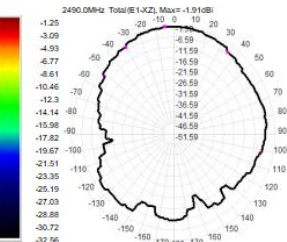
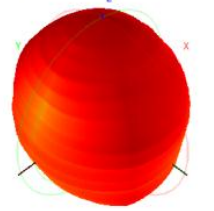

2500.0MHz HHV, Eff: 25.8%

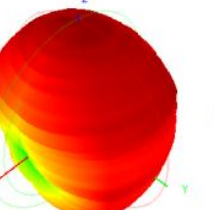

Back View

