

TEST REPORT

Report No.: SHE23060039-04AE

Date: 2023-07-22

Page 1 of 38

Applicant : PETKIT Network Technology (Shanghai) Co., Ltd.
Address of Applicant : Room 4139, Building 2, 588 Zixing Road, Minhang District, Shanghai

Product Name : PETKIT YUMSHARE DUAL-HOPPER WITH CAMERA
SMART PET FEEDER
Brand Name : PETKIT
Model Name : P591
Sample Acquisition Method : Sent by Client
Sample No. : E23060039-02#01
E23060039-02#02

FCC ID : 2A72N-P591

Standards : FCC CFR47 Part 15, Subpart C

Date of Receipt : 2023-07-04
Date of Test : 2023-07-04~ 2023-07-21
Date of Issue : 2023-07-22

Remark:

This report details the results of the testing carried out on one sample, the results contained in this report do not relate to other samples of the same product. The manufacturer should ensure that all products in series production are in conformity with the product sample detailed in this report.

Prepared by:



(Erik Yang)

Reviewed by:



(Jennifer Zhou)

Approved by:



(Authorized signatory: Guoyou Chi)

TEST REPORT

Report No.: SHE23060039-04AE

Date: 2023-07-22

Page 2 of 38

Contents

1	GENERAL INFORMATION	3
1.1	TESTING LABORATORY	3
1.2	DETAILS OF APPLICATION	3
1.3	DETAILS OF EUT	3
1.4	TEST METHODOLOGY	4
1.5	TEST SUMMARY	5
2	TEST CONDITION	6
2.1	ENVIRONMENTAL CONDITIONS	6
2.2	EQUIPMENT LIST	6
2.3	MEASUREMENT UNCERTAINTY	7
3	TEST SET-UP AND OPERATION MODES	8
3.1	DETAILS OF TEST MODE	8
3.2	SPECIAL ACCESSORIES AND AUXILIARY EQUIPMENT	8
3.3	SUPPORT SOFTWARE	8
3.4	TEST SETUP DIAGRAM	9
4	TEST RESULTS	10
4.1	TRANSMITTER REQUIREMENT & TEST SUITES	10
4.1.1	<i>Antenna Requirement</i>	10
4.1.2	<i>Maximum peak conducted output power</i>	11
4.1.3	<i>6dB Bandwidth</i>	13
4.1.4	<i>Maximum conducted output power spectral density</i>	15
4.1.5	<i>Conducted Spurious Emission & Authorized-band band-edge</i>	17
4.1.6	<i>Radiated Emission</i>	24
4.1.7	<i>Band Edge (Restricted-band band-edge)</i>	25
4.2	MAINS EMISSIONS	26
4.2.1	<i>Conducted Emission on AC Mains</i>	26
5	APPENDIXES	29
5.1	PHOTOGRAPHS OF THE SAMPLE	29
5.2	SET-UP FOR CONDUCTED EMISSIONS	37
5.3	SET-UP FOR CONDUCTED RF TEST AT ANTENNA PORT	37
5.4	SET-UP FOR SPURIOUS EMISSIONS BELOW 1GHZ	38
5.5	SET-UP FOR SPURIOUS EMISSIONS ABOVE 1GHZ	38

TEST REPORT

Report No.: SHE23060039-04AE

Date: 2023-07-22

Page 3 of 38

1 General Information

1.1 Testing Laboratory

Company Name	ICAS Testing Technology Service (Shanghai) Co., Ltd.
Address	No.1298 Pingan Rd, Minhang District, Shanghai, China
Telephone	0086 21-51682999
Fax	0086 21-54711112
Homepage	www.icasiso.com

1.2 Details of Application

Applicant Company Name	PETKIT Network Technology (Shanghai) Co., Ltd.
Address	Room 4139, Building 2, 588 Zixing Road, Minhang District, Shanghai
Contact Person	TingHe
Telephone	13916991059
Email	ting.he@petkit.com
Manufacturer Company Name	Dongguan Zhihang Electronic Technology Co., LTD.
Address	Room 701 ,Building 15, No.1, Pushi Road I, Qiaotou Town, Dongguan City, Guangdong Province, China.
Factory Company Name	Dongguan Zhihang Electronic Technology Co., LTD.
Address	Room 701 ,Building 15, No.1, Pushi Road I, Qiaotou Town, Dongguan City, Guangdong Province, China.

1.3 Details of EUT

Product Name	PETKIT YUMSHARE DUAL-HOPPER WITH CAMERA SMART PET FEEDER
Brand Name	PETKIT
Test Model Name	P591
FCC ID	2A72N-P591
Mode of Operation	Bluetooth Version 5.0
Frequency Range	2402MHz ~ 2480MHz
Number of Channels	40(at intervals of 2 MHz)
Modulation Type	BLE <input checked="" type="checkbox"/> GFSK 1Mbps <input type="checkbox"/> GFSK 2Mbps
RF Output Power	-2.77dBm
Antenna Type	PCB Antenna
Antenna Gain	-5.45dBi.
Extreme Temperature Range	-10°C~ +55°C
Test Voltage	DC 5.9V Supply by AC Adapter (Model: TEKA-TB059200US)
Hardware Version	D4H_MAIN_V1.1
Software Version	petkit_D4H_tlsr8258_1_39_202307071601
RF power setting in TEST SW	EMI_Test_Tool_V1.8_Power level setting_3.9dBm

TEST REPORT

Report No.: SHE23060039-04AE

Date: 2023-07-22

Page 4 of 38

Note:

1. The above information was declared by the manufacture.
2. For more details, please refer to the User's manual of the EUT.

Channel List

Channel	Frequency	Channel	Frequency	Channel	Frequency
0	2.402GHz	14	2.430GHz	28	2.458GHz
1	2.404GHz	15	2.432GHz	29	2.460GHz
2	2.406GHz	16	2.434GHz	30	2.462GHz
3	2.408GHz	17	2.436GHz	31	2.464GHz
4	2.410GHz	18	2.438GHz	32	2.466GHz
5	2.412GHz	19	2.440GHz	33	2.468GHz
6	2.414GHz	20	2.442GHz	34	2.470GHz
7	2.416GHz	21	2.444GHz	35	2.472GHz
8	2.418GHz	22	2.446GHz	36	2.474GHz
9	2.420GHz	23	2.448GHz	37	2.476GHz
10	2.422GHz	24	2.450GHz	38	2.478GHz
11	2.424GHz	25	2.452GHz	39	2.480GHz
12	2.426GHz	26	2.454GHz		
13	2.428GHz	27	2.456GHz		

1.4 Test Methodology

47 CFR Part 15, Subpart C	Telecommunication-Radio Frequency Devices-Intentional Radiators
KDB Publication 558074 D01 v05r02	15.247 Meas Guidance.
ANSI C63.10-2013	American National Standard for Testing Unlicensed Wireless Devices

Note(s):

All test items were verified and recorded according to the standards and without any addition/deviation/exclusion during the test.

TEST REPORT

Report No.: SHE23060039-04AE

Date: 2023-07-22

Page 5 of 38

1.5 Test Summary

Test Item	FCC Rules	Result
Antenna Requirement	FCC Part 15.247(b)(4), Part 15.203	PASS
Maximum peak conducted output power	FCC Part 15.247(b)(3)	PASS
6dB Bandwidth	FCC Part 15.247(a)(2)	PASS
Maximum conducted output power spectral density	FCC Part 15.247(e)	PASS
Conducted Spurious Emission & Authorized-band band-edge	FCC Part 15.247(d)	PASS
Radiated Emission	FCC Part 15.247(d), 15.205, 15.209	PASS
Band Edge (Restricted-band band-edge)	FCC Part 15.247(d), 15.205, 15.209	PASS
Conducted Emission on AC Mains	FCC Part 15.207(a)	PASS

TEST REPORT

Report No.: SHE23060039-04AE

Date: 2023-07-22

Page 6 of 38

2 Test Condition

2.1 Environmental conditions

Temperature (°C)	18-25
Humidity (%RH)	40-65
Barometric Pressure (mbar)	960-1060

2.2 Equipment List

Name of Equipment	Manufacturer	Model	Serial No.	Cal. Date	Cal. Due
Spectrum Analyzer	Keysight	N9020B	MY59260184	2022-08-02	2023-08-01
Spectrum Analyzer	Rohde & Schwarz	FSV40N	101450	2023-06-08	2024-06-07
Signal Generator	Rohde & Schwarz	SMR27	100184	2022-08-02	2023-08-01
EMI Test Receiver	Rohde & Schwarz	ESR 7	101911	2023-06-08	2024-06-07
EMI Test Receiver	Rohde & Schwarz	ESPI3	100173	2023-06-08	2024-06-07
V-network	SCHWARZBECK	NSLK8127	8127-902	2023-06-07	2024-06-06
Broadband Antenna	SCHWARZBECK	VULB9163	9163-1037	2023-03-22	2025-03-21
Horn Antenna-18G	SCHWARZBECK	BBHA9120D	9120D-1775	2023-06-13	2025-06-12
Loop Antenna	SCHWARZBECK	FMZB 1513	/	2023-06-09	2024-06-08
Horn Antenna-40G	YINGLIAN	LB-180400-KF	N/A	2023-06-18	2025-06-17
Broadband Preamplifier	SCHWARZBECK	BBV 9718	346	2023-06-08	2024-06-07
EMC chamber 9*6*6(L*W*H)	CHANGNING	966	N/A	2023-06-09	2026-06-08
Test Software	BL	BL410_E	Version:1.0.0.117	N/A	N/A
Test Software	BL	BL410_R	Version:2.1.1.409	N/A	N/A

TEST REPORT

Report No.: SHE23060039-04AE

Date: 2023-07-22

Page 7 of 38

2.3 Measurement Uncertainty

The uncertainty is calculated using the methods suggested in the “Guide to the Expression of Uncertainty in measurement” (GUM) published by CISPR and ANSI. The reported uncertainty of measurement $y \pm U$, where expanded uncertainty U is based on a standard uncertainty multiplied by a coverage factor of $k=2$, providing a level of confidence of approximately 95.45%.

Parameter		Uncertainty
Antenna Port Conducted Emission	< 1GHz	± 1.5 dB
	> 1GHz	± 1.5 dB
Radiated Emission	9KHz – 30MHz	± 3.42 dB
	30 MHz – 1GHz	± 5.00 dB
	> 1GHz	± 4.88 dB
Conducted Emission on AC Mains	150kHz-30MHz	± 2.68 dB
Occupied Channel Bandwidth		± 5 %

TEST REPORT

Report No.: SHE23060039-04AE

Date: 2023-07-22

Page 8 of 38

3 Test Set-up and Operation Modes

3.1 Details of Test Mode

Using test software was control EUT work in continuous transmitter and receiver mode. Select test channel as below:

Channel	Frequency
The lowest channel(CH00)	2402MHz
The middle channel(CH19)	2440MHz
The Highest channel(CH39)	2480MHz

The basic operation modes are:

- A. On
 - 1. BLE mode
 - a. Transmitting
 - i. Low Channel
 - ii. Middle Channel
 - iii. High Channel
 - b. Receiving
 - 2. Normal working with Bluetooth on
- B. Standby
- C. Off

3.2 Special Accessories and Auxiliary Equipment

Description	Manufacturer	Model Name	Serial No.
Laptop	Lenovo	TP00083A	N/A
USB Cable	N/A	N/A	1.00m Unshielded
AC ADAPTER	TEKA	TEKA-TB059200US	Input: AC 100-240V 50/60Hz 0.35A Max; Output: DC 5.9V 2A

3.3 Support Software

Description	Manufacturer	Software Name
Software	N/A	EMI_Test_Tool_V1.8

TEST REPORT

Report No.: SHE23060039-04AE

Date: 2023-07-22

Page 9 of 38

3.4 Test Setup Diagram

Diagram of Measurement Configuration for Radiation Test

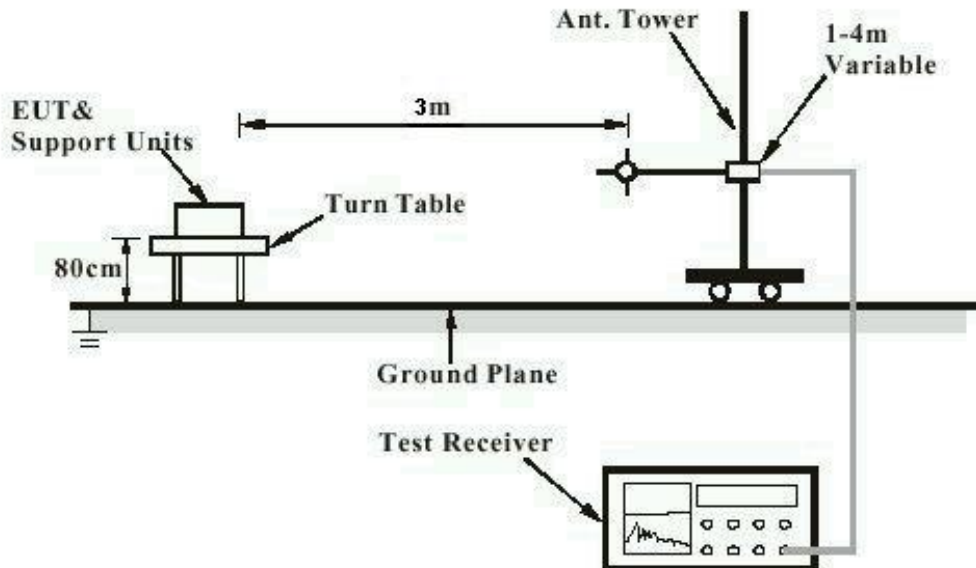

Note: Measurements above 1GHz are done with a table height of 1.5m. In addition, there is RF absorbing material on the floor of the test site for above 1GHz measurement.

Diagram of Measurement Equipment Configuration for Transmitter Test

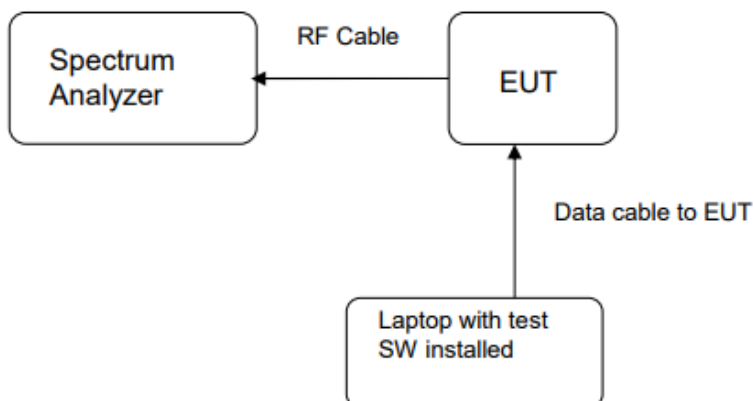

TEST REPORT

Report No.: SHE23060039-04AE

Date: 2023-07-22

Page 10 of 38

4 Test Results

4.1 Transmitter Requirement & Test Suites

4.1.1 Antenna Requirement

RESULT:

PASS

Test standard : FCC Part 15.247(b)(4), Part 15.203

Requirement : The use of approved antennas only with directional gains that do not exceed 6dBi

According to the manufacturer declaration, an antenna with a directional gain of -5.45dBi. The antenna is PCB antenna with no possibility of replacement with a non-approved antenna by the end-user.

Therefore, the EUT is considered to comply with this provision.

TEST REPORT

Report No.: SHE23060039-04AE

Date: 2023-07-22

Page 11 of 38

4.1.2 Maximum peak conducted output power

RESULT:

PASS

Test standard : FCC Part 15.247(b)(3)
 Requirement : ANSI C63.10-2013 clause 11.9.1.1,
 KDB 558074 D01 v05r02, Clause 8.3.1
 Kind of test site : Shielded room

Test setup

Test Channel : Low/Middle/High
 Operation Mode : A.1.a
 Ambient temperature : 24.9°C
 Relative humidity : 56%

Table 1: Maximum peak conducted output power

Test Mode	Test Channel (MHz)	Maximum peak conducted output power		Limit (W)
		(dBm)	(mW)	
BLE	2402	-2.77	0.53	< 1
	2440	-2.81	0.52	
	2480	-2.78	0.53	

Figure 1: Peak Output Power, 2402MHz

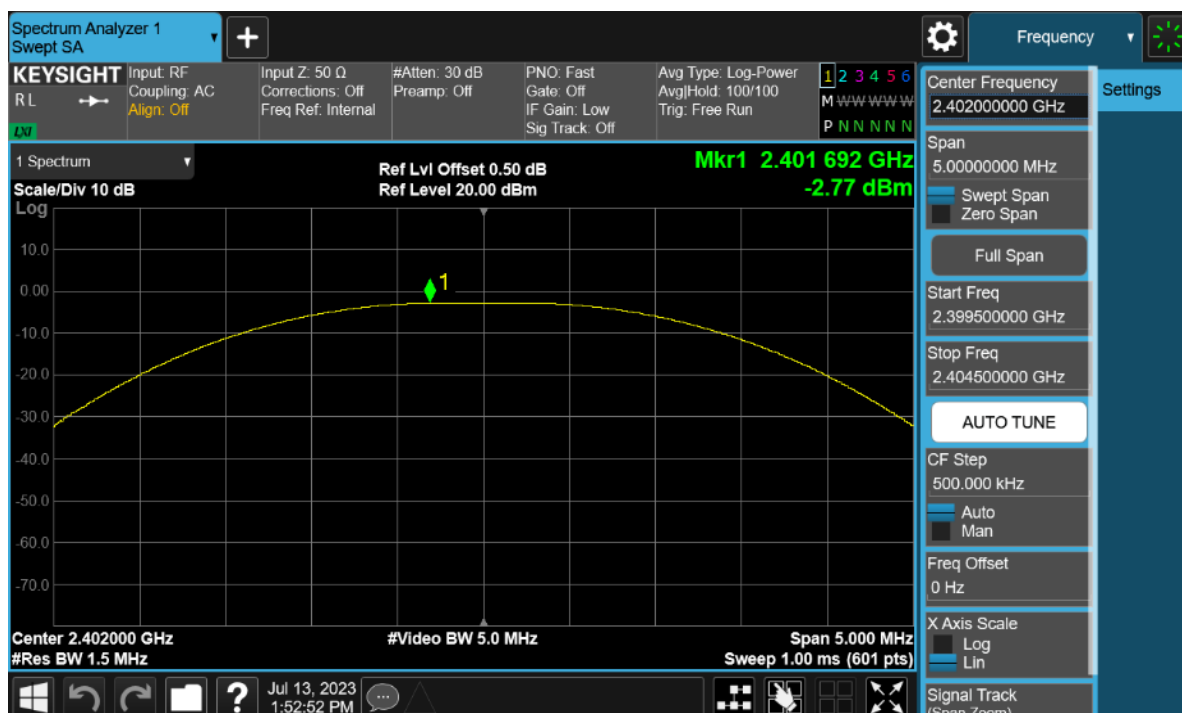

TEST REPORT

Report No.:

SHE23060039-04AE

Date:

2023-07-22

Page 12 of 38

Figure 2: Peak Output Power, 2440MHz

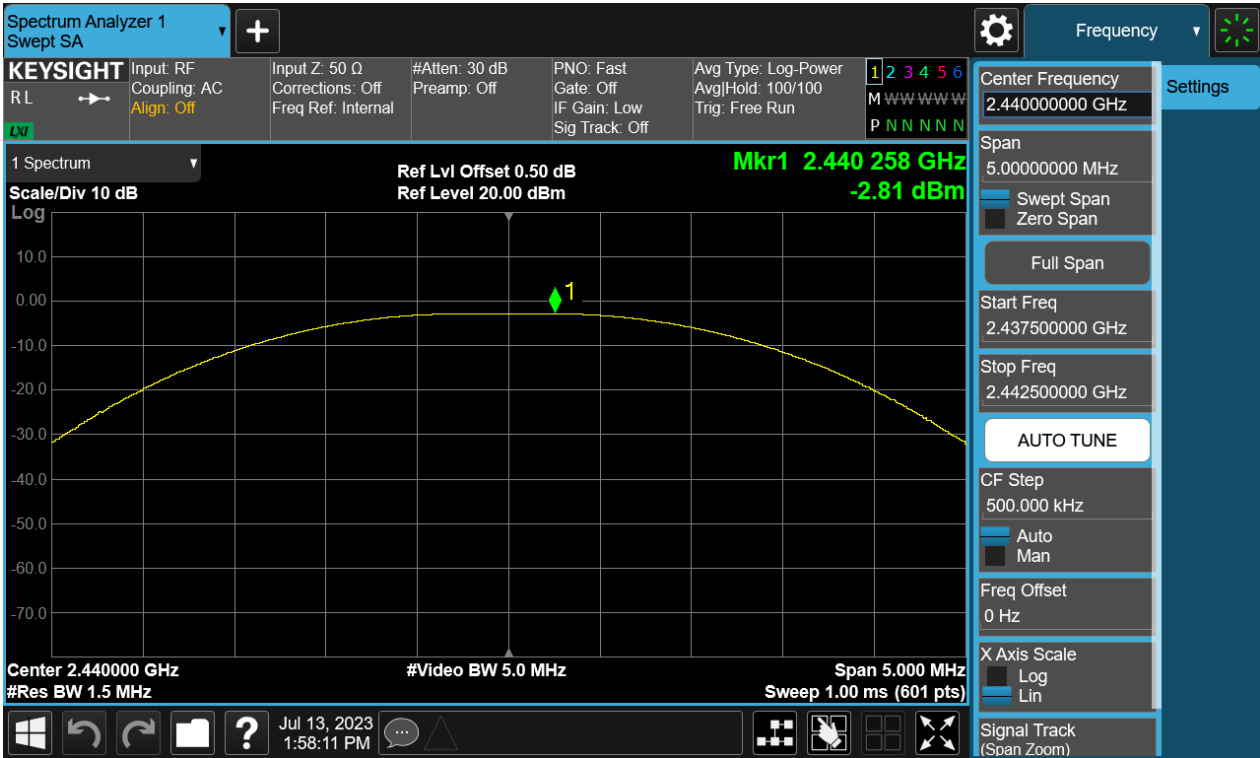
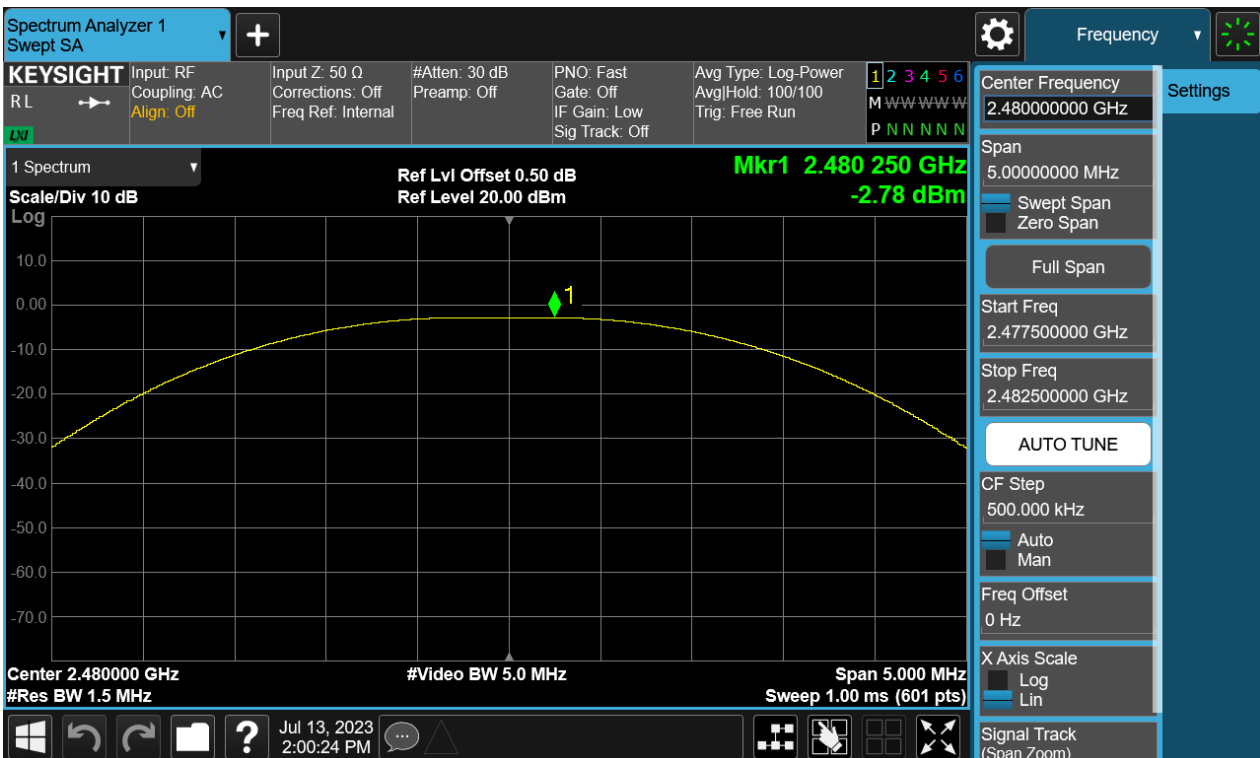

Figure 3: Peak Output Power, 2480MHz



TEST REPORT

Report No.: SHE23060039-04AE

Date: 2023-07-22

Page 13 of 38

4.1.3 6dB Bandwidth

RESULT:

PASS

Test standard : FCC Part 15.247(a)(2)
 Requirement : ANSI C63.10-2013 clause 11.8.1,
 KDB 558074 D01 v05r02, Clause 8.2
 Kind of test site : Shielded room

Test setup

Test Channel : Low/Middle/High
 Operation Mode : A.1.a
 Ambient temperature : 24.9°C
 Relative humidity : 56%

Table 2: 6dB Bandwidth

Test Mode	Test Channel (MHz)	6dB Bandwidth (MHz)	Limit
BLE	2402	0.6652	≥0.5 MHz
	2440	0.6986	
	2480	0.6624	

Figure 4: 6dB Bandwidth, 2402MHz

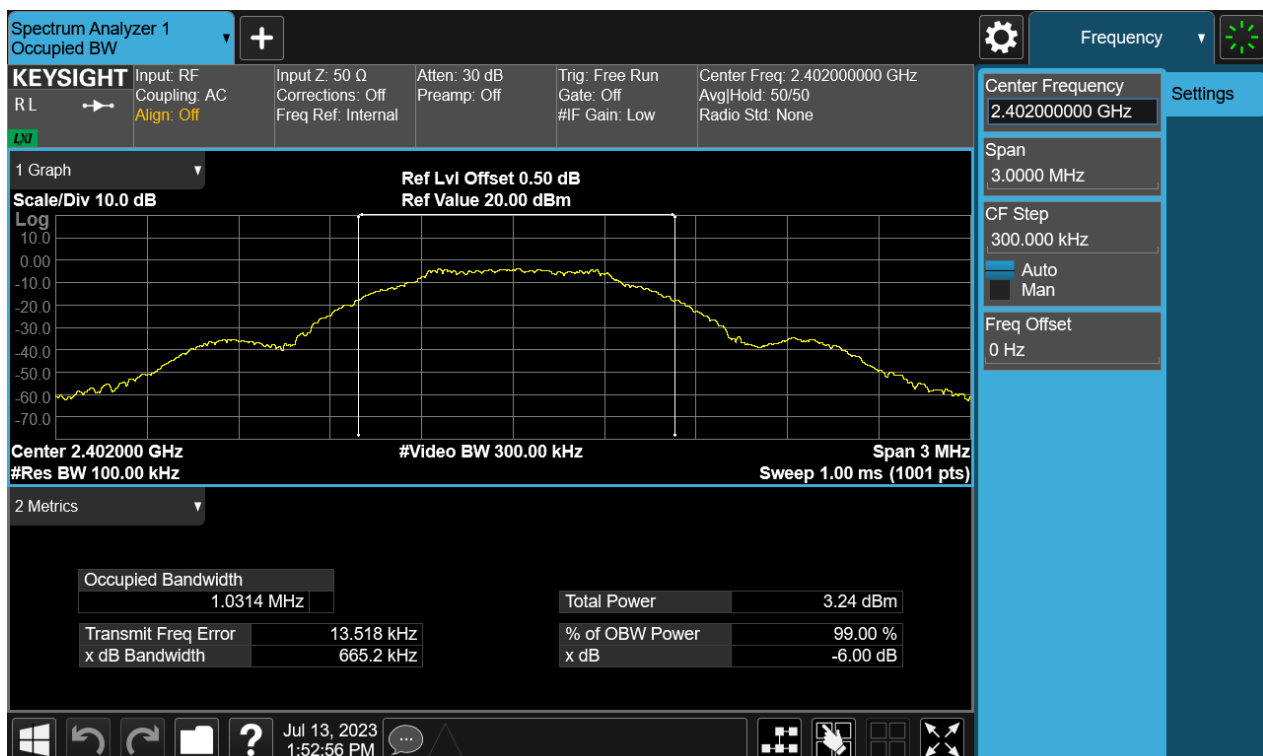

TEST REPORT

Report No.:

SHE23060039-04AE

Date:

2023-07-22

Page 14 of 38

Figure 5: 6dB Bandwidth, 2440MHz



Figure 6: 6dB Bandwidth, 2480MHz

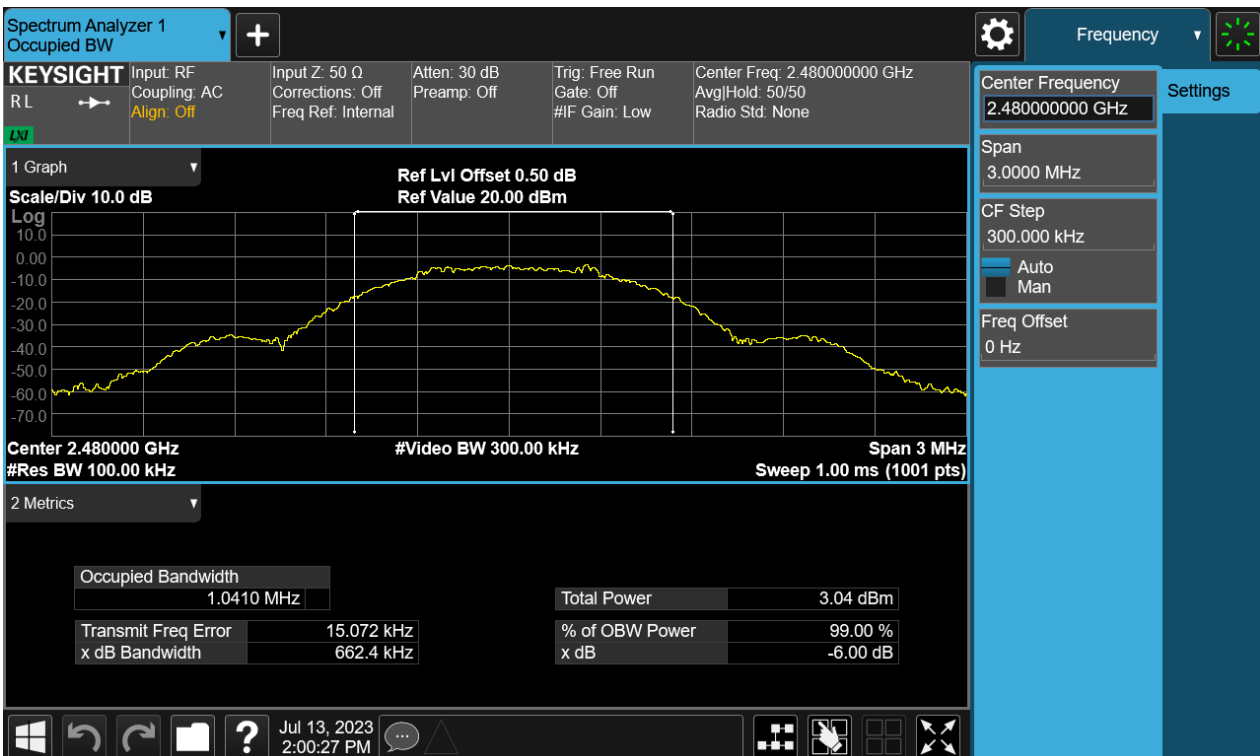

TEST REPORT

Report No.: SHE23060039-04AE

Date: 2023-07-22

Page 15 of 38

4.1.4 Maximum conducted output power spectral density

RESULT:

PASS

Test standard : FCC Part 15.247(e)
 Requirement : ANSI C63.10-2013 clause 11.10.2,
 KDB 558074 D01 v05r02, Clause 8.4
 Kind of test site : Shielded room

Test setup

Test Channel : Low/Middle/High
 Operation Mode : A.1.a
 Ambient temperature : 24.9°C
 Relative humidity : 56%

Table 3: Maximum conducted output power spectral density

Test Mode	Test Channel (MHz)	Measured Result (dBm/3kHz)	Limit (dBm/3kHz)
BLE	2402	-14.92	8
	2440	-15.33	
	2480	-14.36	

Figure 7: Power Spectral Density, 2402MHz

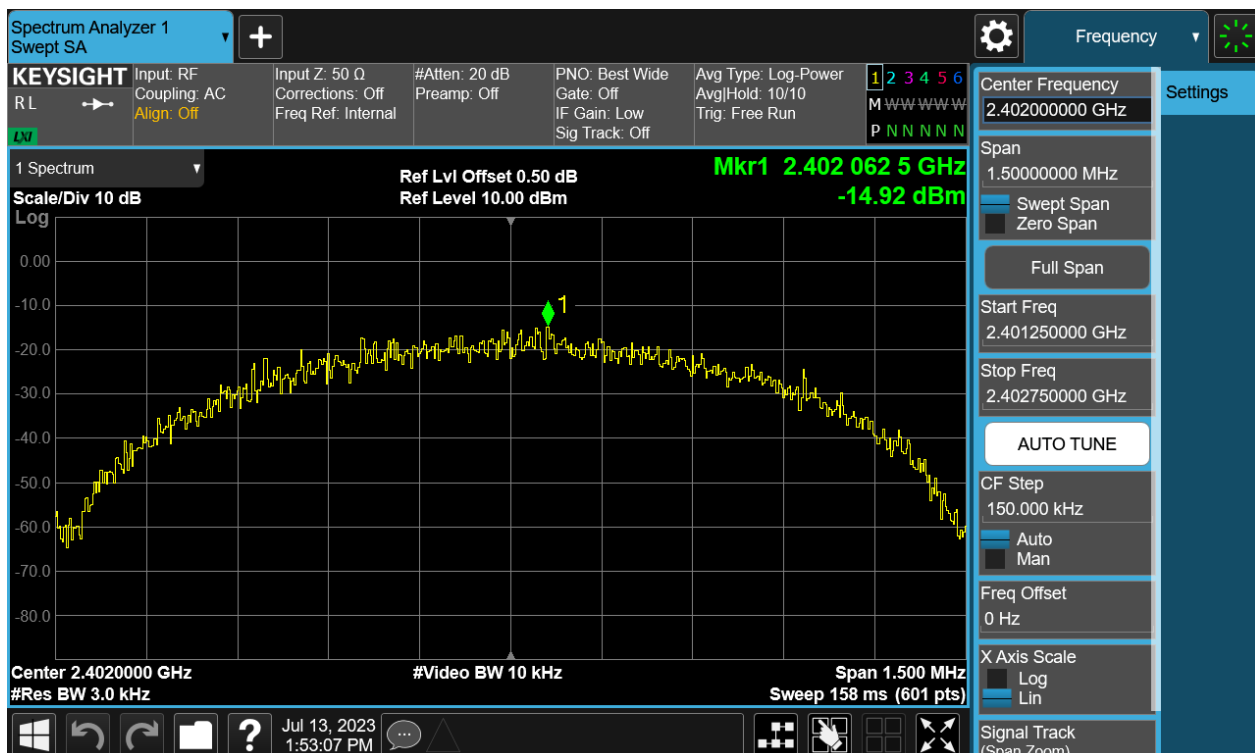

TEST REPORT

Report No.: SHE23060039-04AE

Date: 2023-07-22

Page 16 of 38

Figure 8: Power Spectral Density, 2440MHz

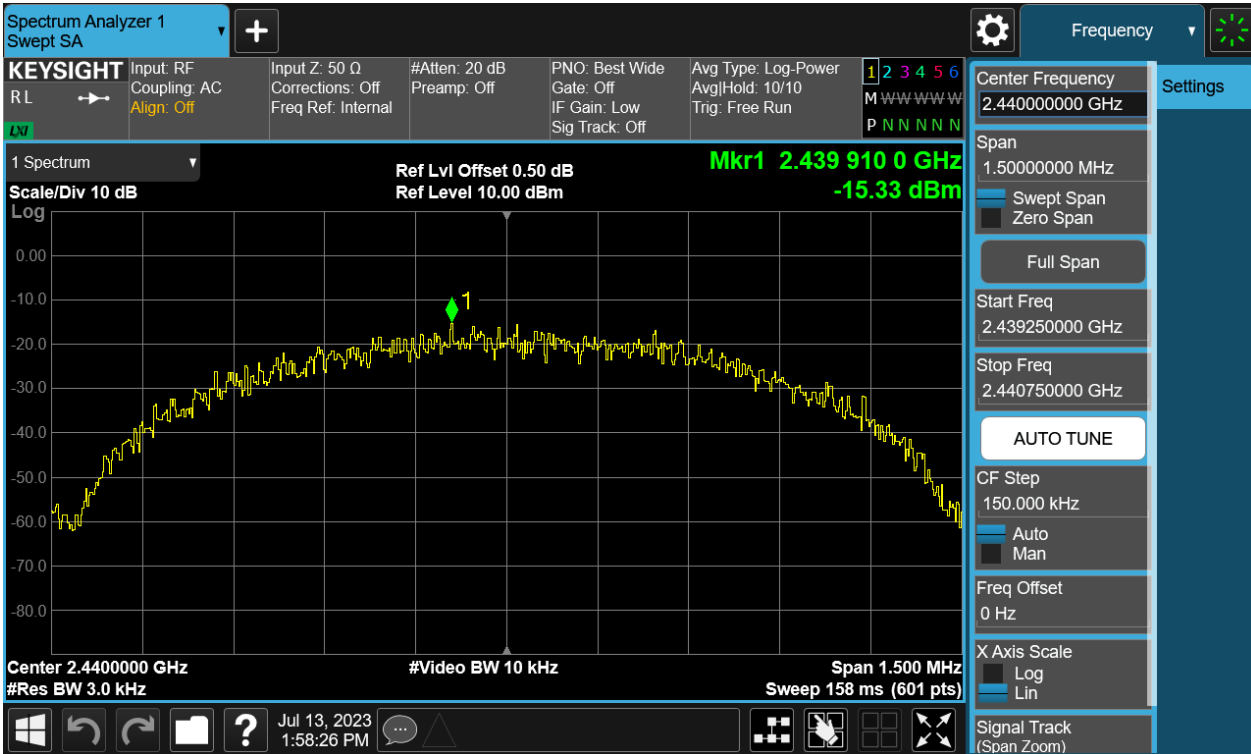
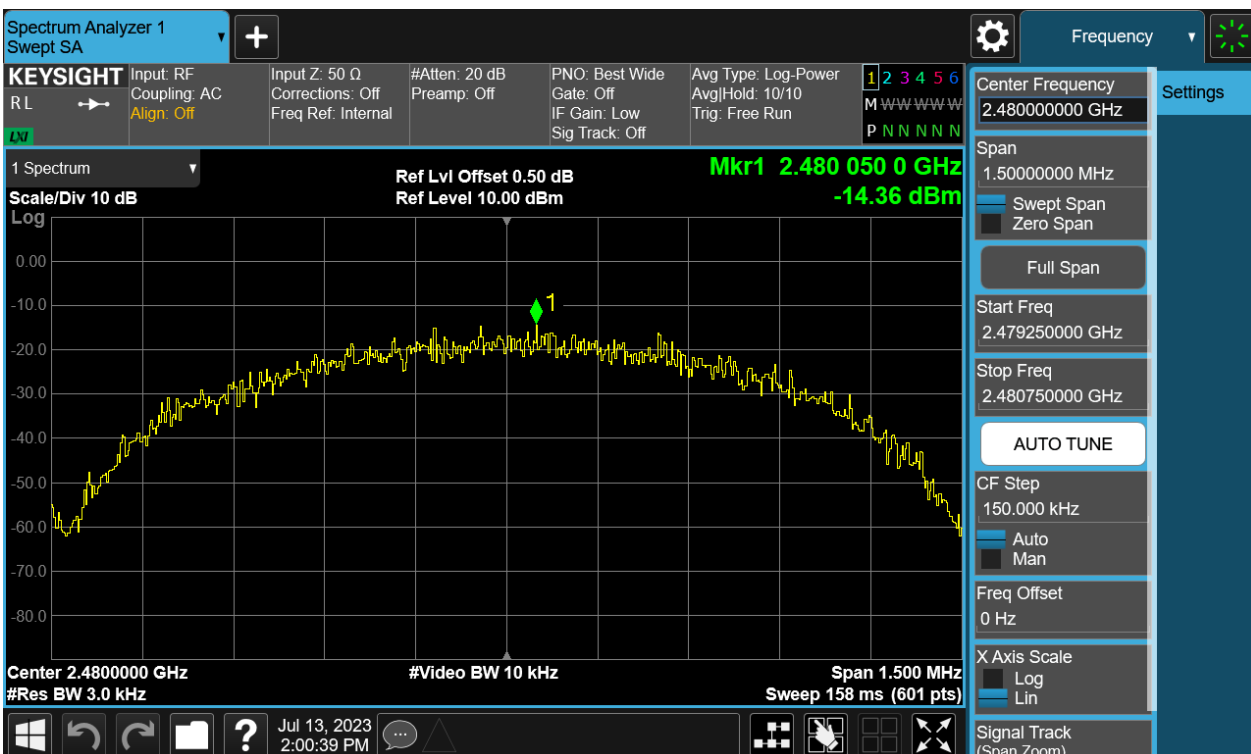

Figure 9: Power Spectral Density, 2480MHz



TEST REPORT

Report No.: SHE23060039-04AE

Date: 2023-07-22

Page 17 of 38

4.1.5 Conducted Spurious Emission & Authorized-band band-edge

RESULT:

PASS

Test standard : FCC Part 15.247(d)
Requirement : ANSI C63.10-2013, Clause 11.11.1(a)
KDB 558074 D01 v05r02, Clause 8.5
Kind of test site : Shielded room

Test setup

Test Channel : Low/Middle/High for spurious, Low/High for Band
Edge
Operation Mode : A.1.a
Ambient temperature : 24.9°C
Relative humidity : 56%

For details refer to following test plot.

TEST REPORT

Report No.:

SHE23060039-04AE

Date:

2023-07-22

Page 18 of 38

Figure 4: Conducted Spurious Emission & Authorized-band band-edge, 2402MHz, BLE Carrier Level

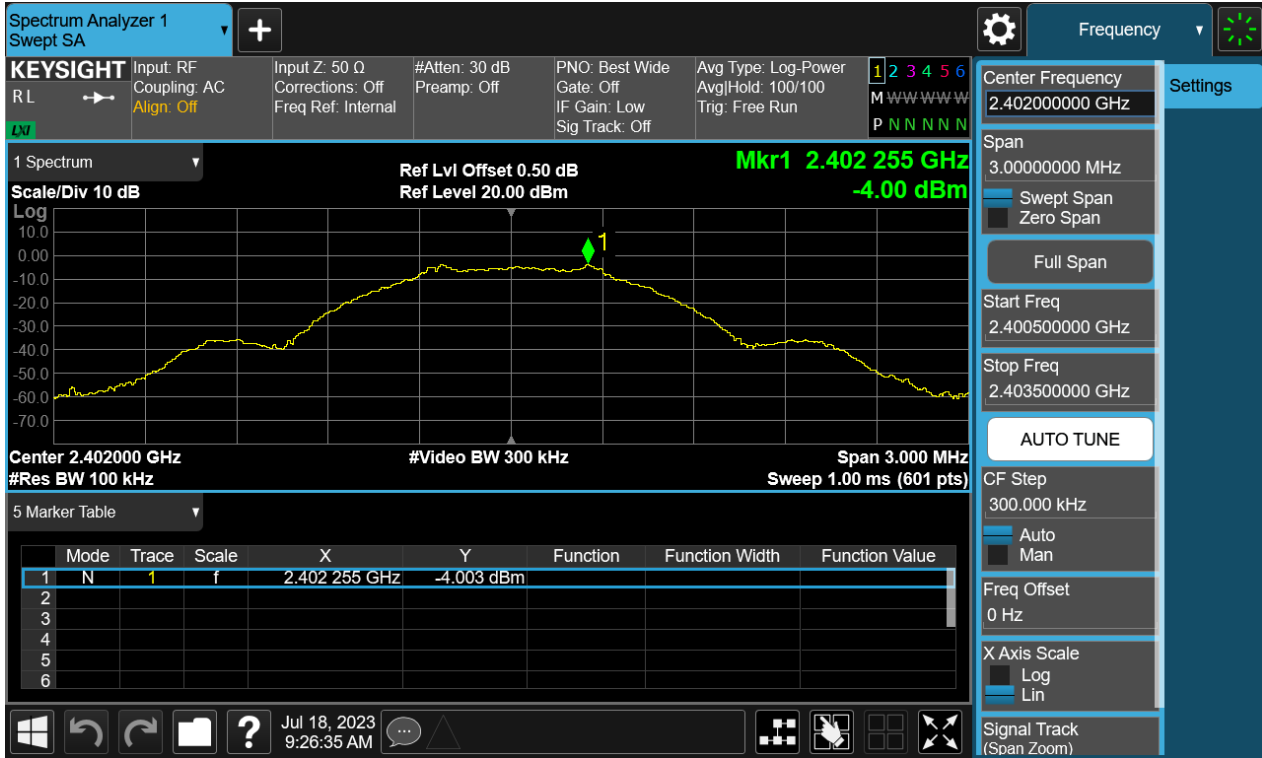

Band Edge

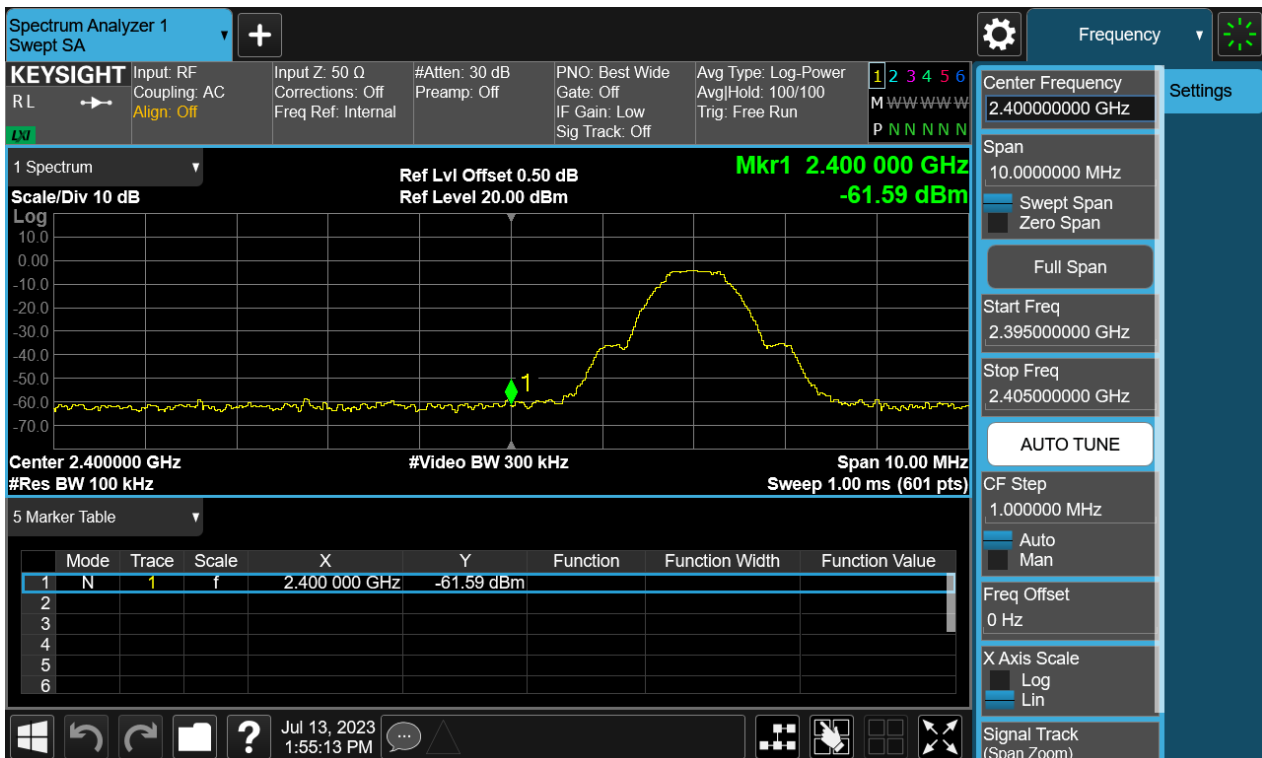

TEST REPORT

Report No.: SHE23060039-04AE

Date: 2023-07-22

Page 19 of 38

Conducted spurious emissions 30MHz-25GHz

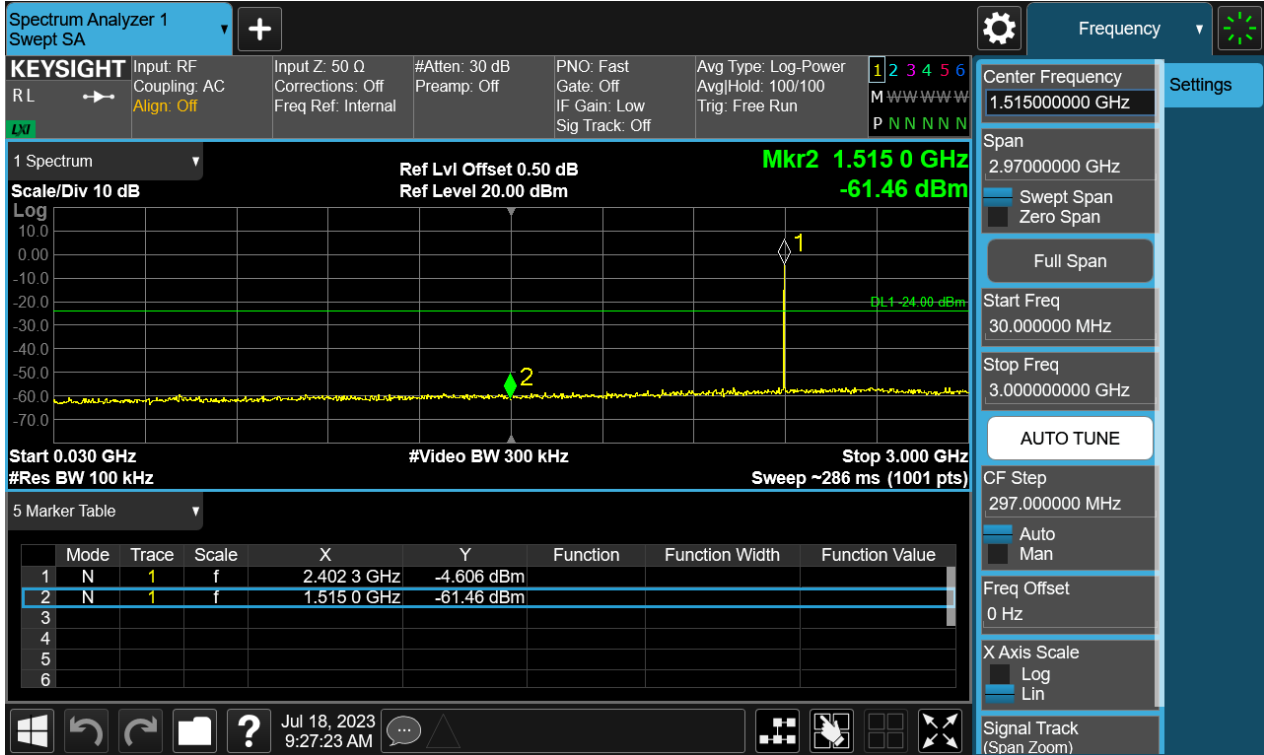

TEST REPORT

Report No.:

SHE23060039-04AE

Date:

2023-07-22

Page 20 of 38

Figure 5: Conducted Spurious Emission & Authorized-band band-edge, 2440MHz, BLE Carrier Level

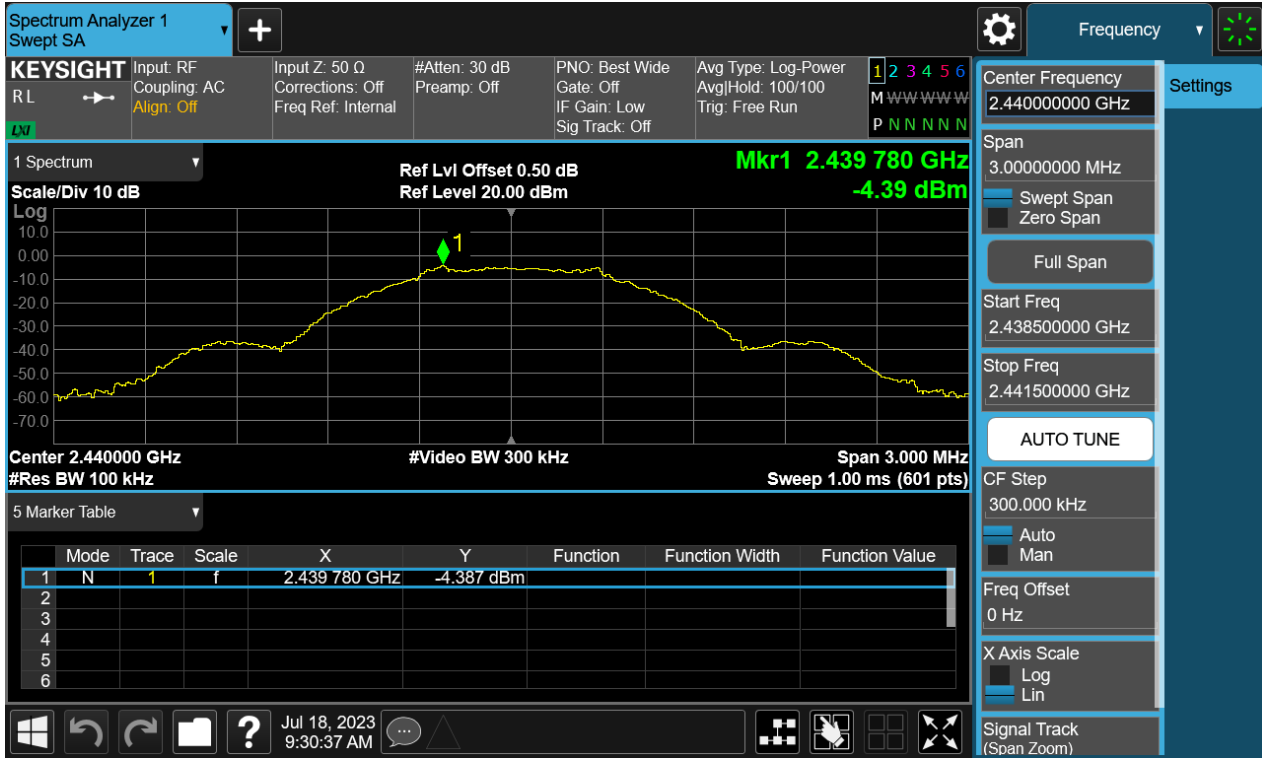

Conducted spurious emissions 30MHz-25GHz

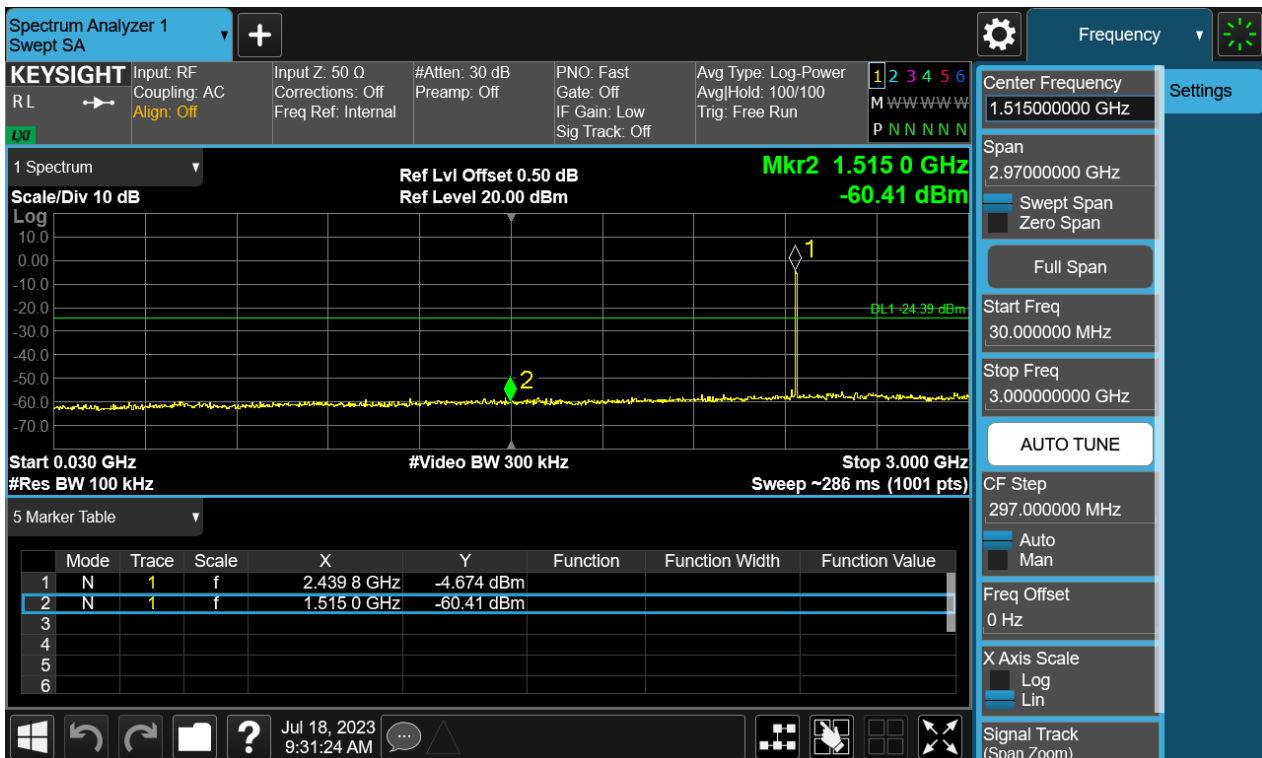

TEST REPORT

Report No.:

SHE23060039-04AE

Date:

2023-07-22

Page 21 of 38

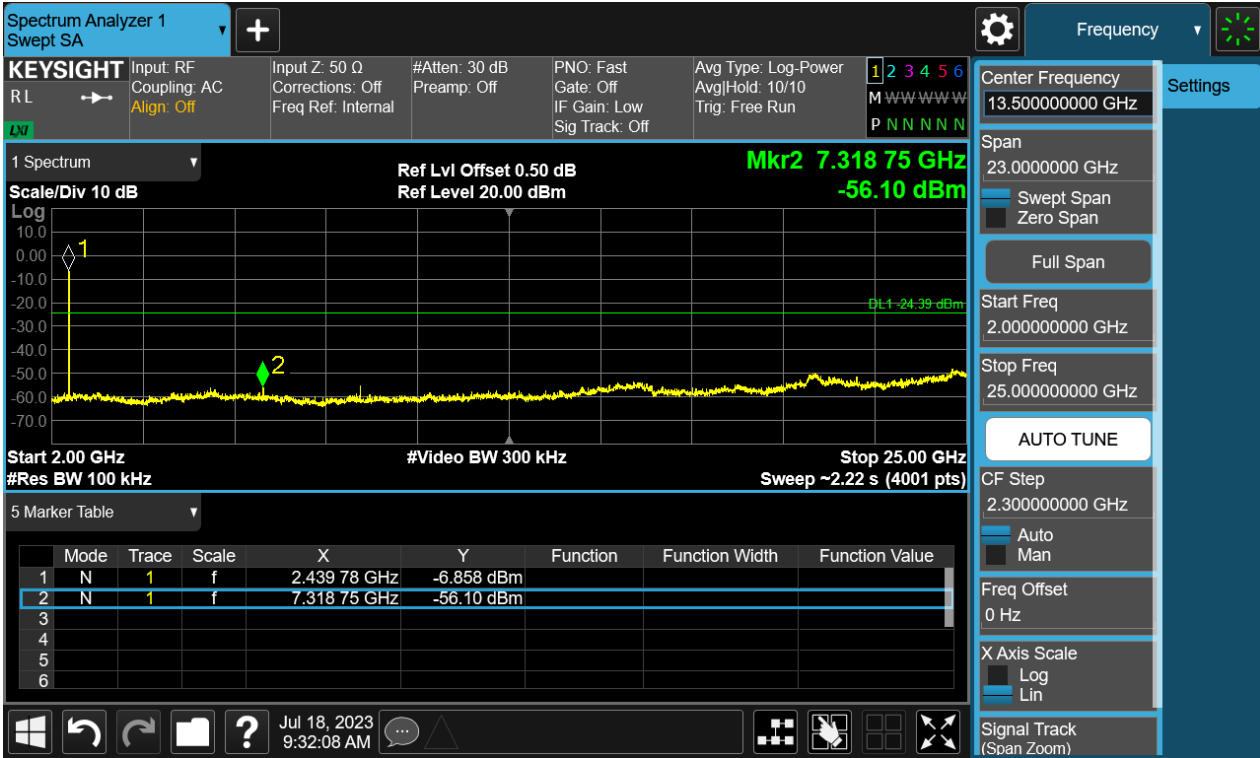

Figure 6: Conducted Spurious Emission & Authorized-band band-edge, 2480MHz, BLE Carrier Level



TEST REPORT

Report No.:

SHE23060039-04AE

Date:

2023-07-22

Page 22 of 38

Band Edge



Conducted spurious emissions 30MHz-25GHz

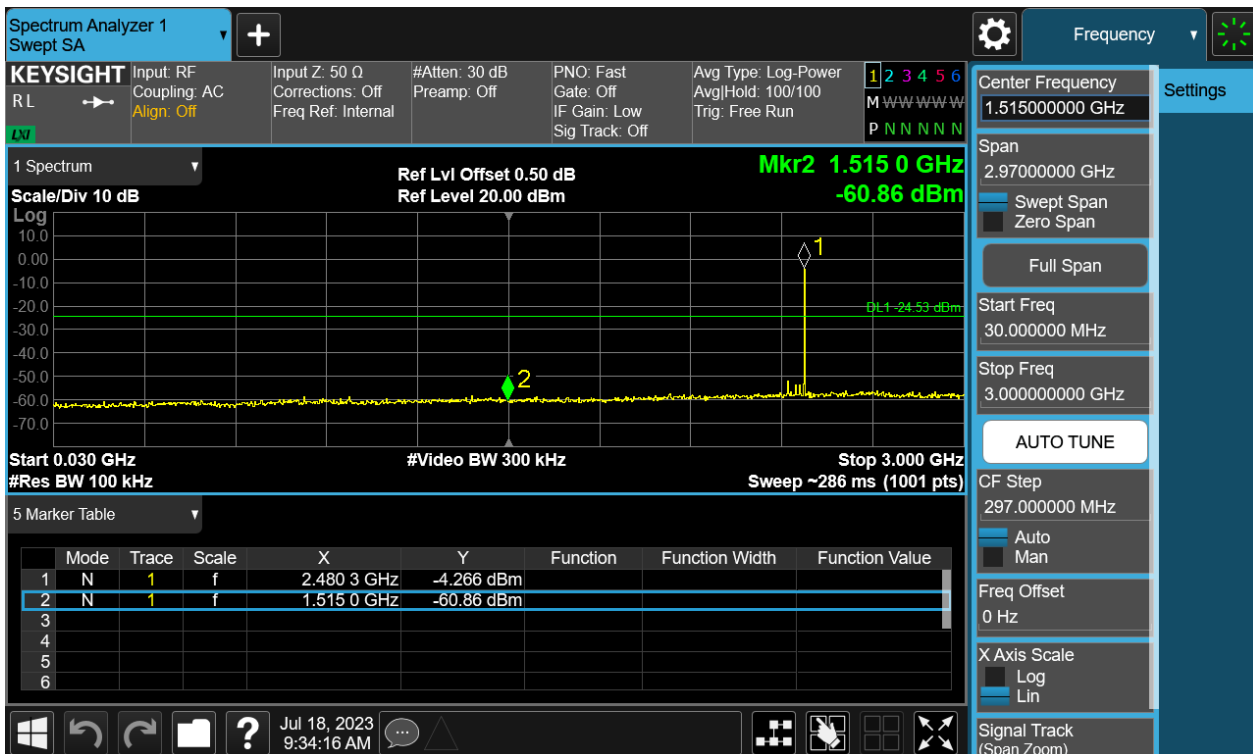

TEST REPORT

Report No.:

SHE23060039-04AE

Date:

2023-07-22

Page 23 of 38

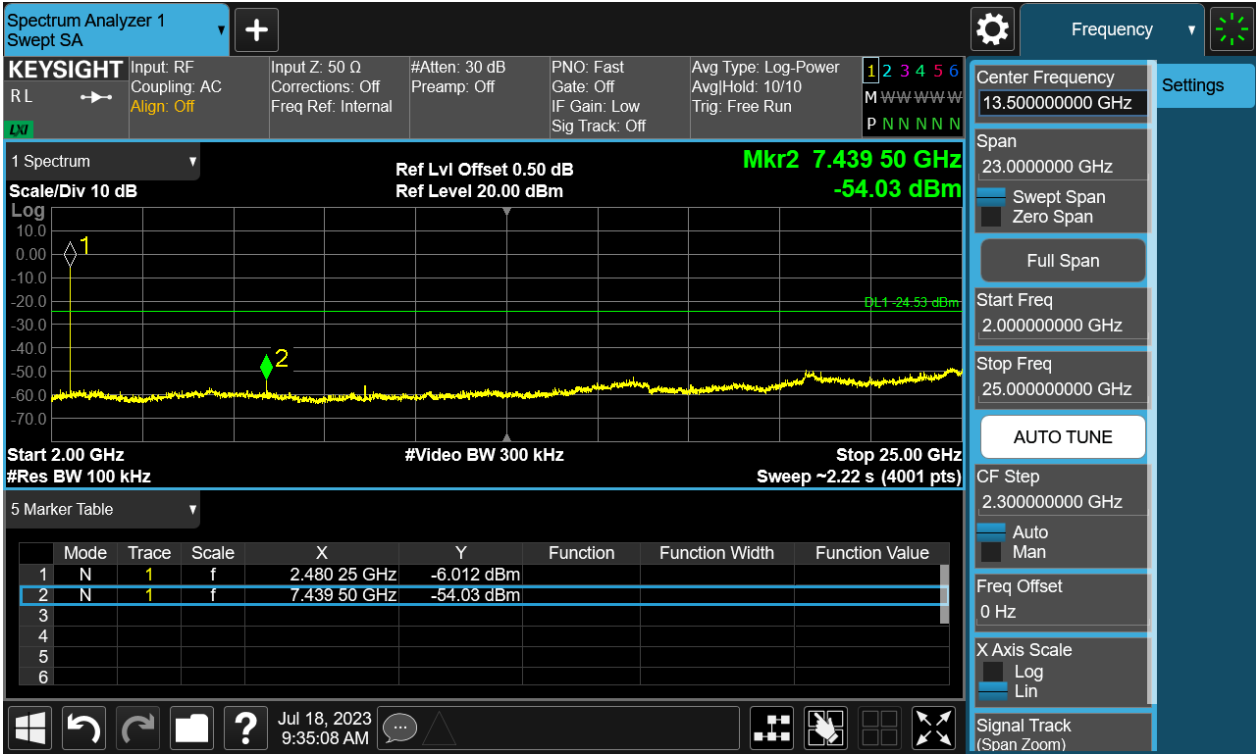

TEST REPORT

Report No.: SHE23060039-04AE

Date: 2023-07-22

Page 24 of 38

4.1.6 Radiated Emission

RESULT:

PASS

Test standard : FCC Part 15.247(d), 15.205, 15.209
Requirement : ANSI C63.10-2013 clause 11.12,
KDB 558074 D01 v05r02, Clause 8.6
Kind of test site : 3m Semi-Anechoic Chamber

Test setup

Test Channel : Low/Middle/High
Operation Mode : A
Ambient temperature : 24.5°C
Relative humidity : 53%

Notes

Test plots please refer to the annex document "SHE23060039-04AE DATA BLE-TX EXHIBIT A".

1. For 9 kHz ~ 30 MHz, the amplitude of spurious emissions that are attenuated by more than 20dB below the permissible. The value has no need to be reported. In addition, During 30MHz to 1GHz test frequency range, only the worst mode data was reported in this report.
2. The spurious above 18GHz is noise only and 20dB below the limit. The value has no need to be reported.
3. The EUT was pretested with 3 orientations placed on the table for the radiated emission measurement -X, Y, and Z-plane. The X-plane results were found as the worst case and were shown in this report.

TEST REPORT

Report No.: SHE23060039-04AE

Date: 2023-07-22

Page 25 of 38

4.1.7 Band Edge (Restricted-band band-edge)

RESULT:

PASS

Test standard : FCC Part 15.247(d), 15.205, 15.209
Requirement : ANSI C63.10-2013 clause 11.13,
KDB 558074 D01 v05r02, Clause 8.7
Kind of test site : 3m Semi-Anechoic Chamber

Test setup

Test Channel : Low/Middle/High
Operation Mode : A.1
Ambient temperature : 24.5°C
Relative humidity : 53%

Notes

Test plots please refer to the annex document "SHE23060039-04AE DATA BLE-TX EXHIBIT A".

TEST REPORT

Report No.: SHE23060039-04AE

Date: 2023-07-22

Page 26 of 38

4.2 Mains Emissions

4.2.1 Conducted Emission on AC Mains

RESULT:

PASS

Test standard : FCC Part 15.207(a)
Requirement : ANSI C63.10-2013, Clause 6.2
Kind of test site : Shielded room

Test setup

Input Voltage : DC 5.9V supply by AC adapter (which received AC 120V, 60Hz)
Operation Mode : A.1.a
Earthing : Disconnected to GND
Ambient temperature : 21°C
Relative humidity : 50%

For details refer to following test plot.

TEST REPORT

Report No.: SHE23060039-04AE

Date: 2023-07-22

Page 27 of 38

Note: The all configurations were tested respectively, but only the worst data (at middle channel) shown here.

Figure 13: Conducted Emission on AC Mains, L Phase

CEmission Test case_FCC_CE_FCC PART 15C

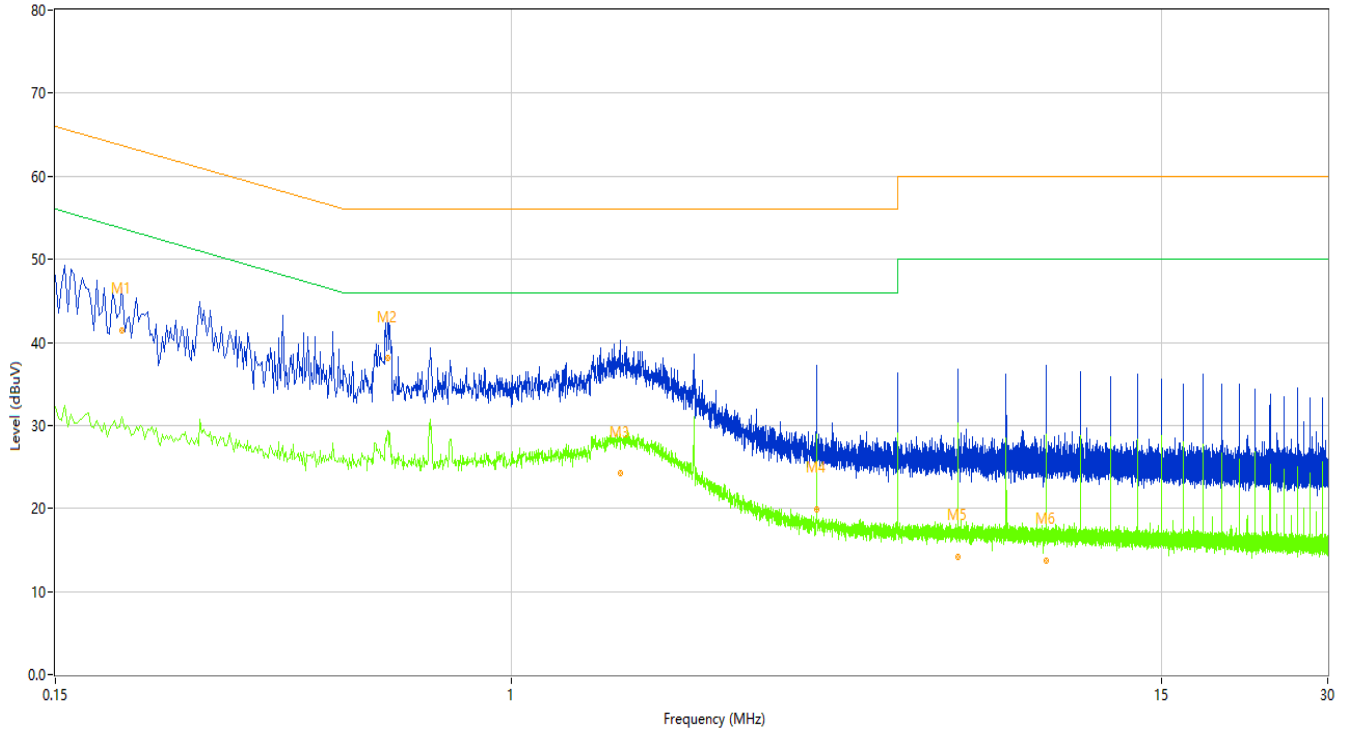

No.	Frequency (MHz)	Results (dBuV)	Factor (dB)	Limit (dBuV)	Margin (dB)	Detector	Line	Verdict
1	0.198	47.17	9.94	63.69	16.52	Peak	L	Pass
1*	0.198	41.49	9.94	63.69	22.20	QP	L	Pass
1**	0.198	31.05	9.94	53.69	22.64	AV	L	Pass
2	0.598	43.02	9.97	56.00	12.98	Peak	L	Pass
2*	0.598	38.10	9.97	56.00	17.90	QP	L	Pass
2**	0.598	29.42	9.97	46.00	16.58	AV	L	Pass
3	1.576	30.85	9.85	56.00	25.15	Peak	L	Pass
3*	1.576	24.20	9.85	56.00	31.80	QP	L	Pass
3**	1.576	27.16	9.85	46.00	18.84	AV	L	Pass
4	3.574	26.81	9.82	56.00	29.19	Peak	L	Pass
4*	3.574	19.84	9.82	56.00	36.16	QP	L	Pass
4**	3.574	27.96	9.82	46.00	18.04	AV	L	Pass
5	6.432	21.98	9.79	60.00	38.02	Peak	L	Pass
5*	6.432	14.18	9.79	60.00	45.82	QP	L	Pass
5**	6.432	30.35	9.79	50.00	19.65	AV	L	Pass
6	9.294	21.88	9.71	60.00	38.12	Peak	L	Pass
6*	9.294	13.76	9.71	60.00	46.24	QP	L	Pass
6**	9.294	27.80	9.71	50.00	22.20	AV	L	Pass

TEST REPORT

Report No.: SHE23060039-04AE

Date: 2023-07-22

Page 28 of 38

Figure 14: Conducted Emission on AC Mains, N Phase

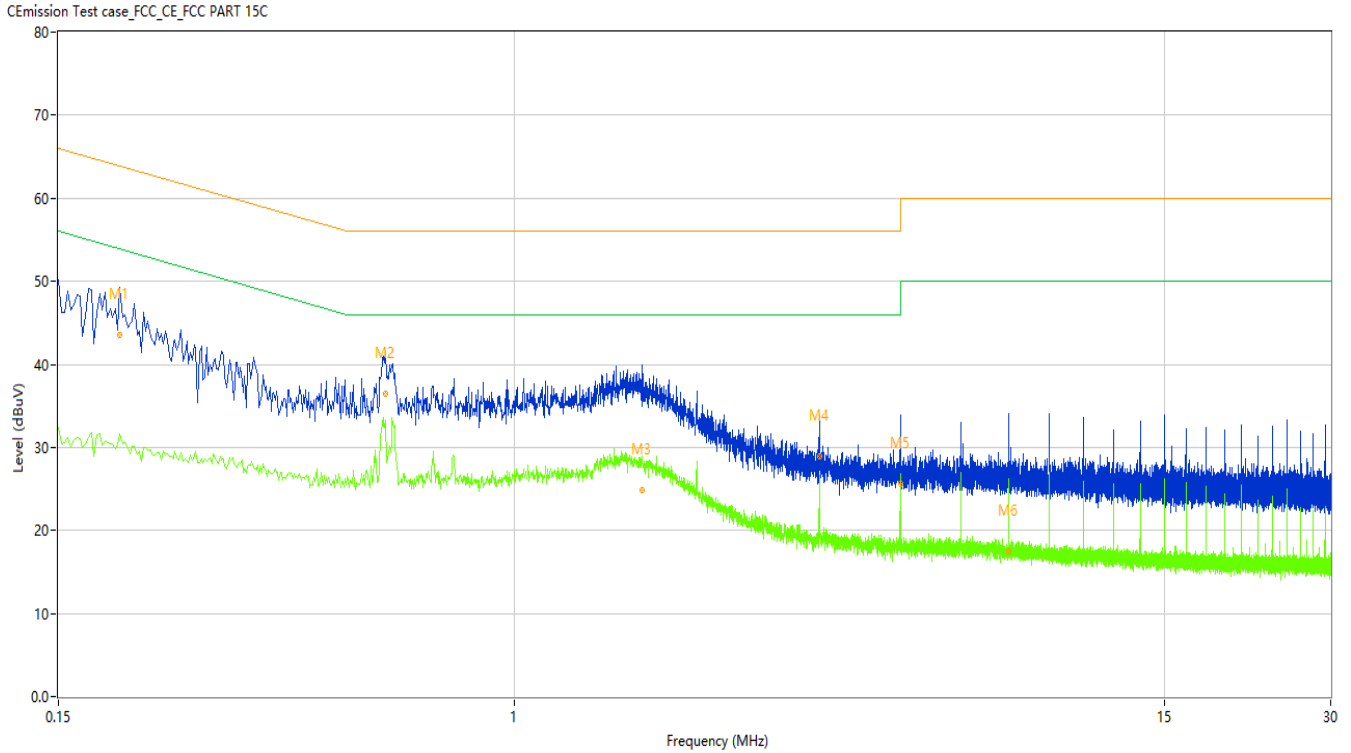

No.	Frequency (MHz)	Results (dBuV)	Factor (dB)	Limit (dBuV)	Margin (dB)	Detector	Line	Verdict
1	0.194	49.12	10.03	63.86	14.74	Peak	N	Pass
1*	0.194	43.51	10.03	63.86	20.35	QP	N	Pass
1**	0.194	31.67	10.03	53.86	22.19	AV	N	Pass
2	0.586	40.71	10.07	56.00	15.29	Peak	N	Pass
2*	0.586	36.52	10.07	56.00	19.48	QP	N	Pass
2**	0.586	33.31	10.07	46.00	12.69	AV	N	Pass
3	1.702	32.40	9.94	56.00	23.60	Peak	N	Pass
3*	1.702	24.80	9.94	56.00	31.20	QP	N	Pass
3**	1.702	28.92	9.94	46.00	17.08	AV	N	Pass
4	3.572	32.90	9.89	56.00	23.10	Peak	N	Pass
4*	3.572	28.90	9.89	56.00	27.10	QP	N	Pass
4**	3.572	26.62	9.89	46.00	19.38	AV	N	Pass
5	5.000	31.06	9.72	56.00	24.94	Peak	N	Pass
5*	5.000	25.54	9.72	56.00	30.46	QP	N	Pass
5**	5.000	26.84	9.72	46.00	19.16	AV	N	Pass
6	7.856	24.49	9.82	60.00	35.51	Peak	N	Pass
6*	7.856	17.53	9.82	60.00	42.47	QP	N	Pass
6**	7.856	25.90	9.82	50.00	24.10	AV	N	Pass

TEST REPORT

Report No.: SHE23060039-04AE

Date: 2023-07-22

Page 29 of 38

5 Appendixes

5.1 Photographs of the Sample



All of the sample



Front of the sample

TEST REPORT

Report No.:

SHE23060039-04AE

Date:

2023-07-22

Page 30 of 38



Rear of the sample

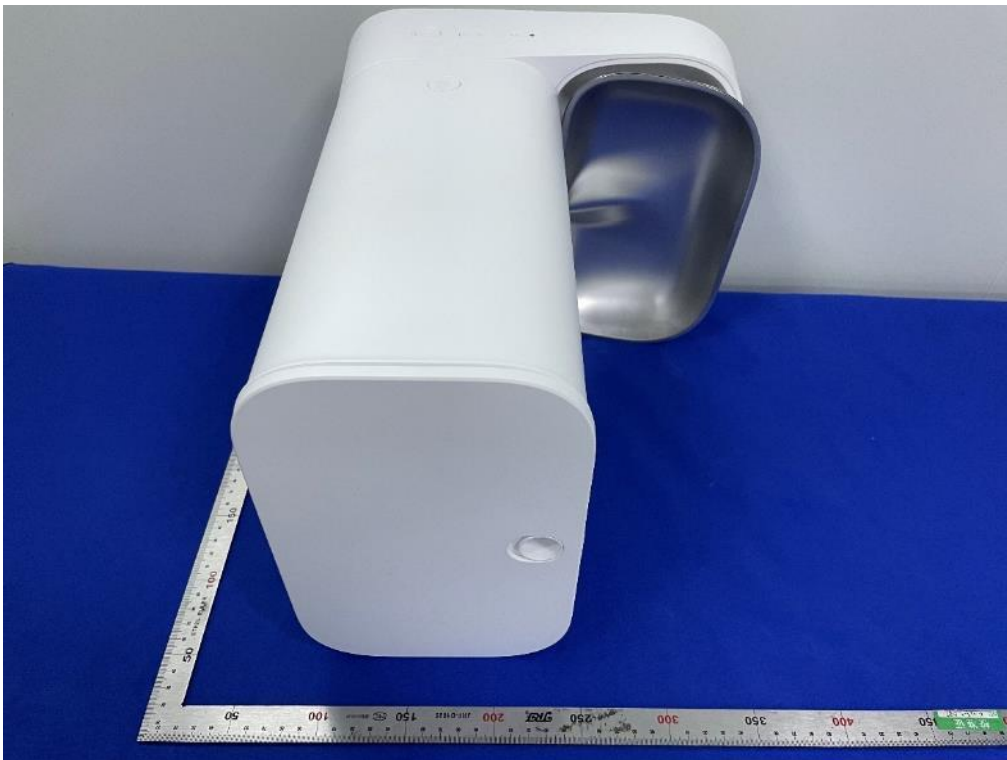

Top of the sample

TEST REPORT

Report No.:

SHE23060039-04AE

Date:

2023-07-22

Page 31 of 38

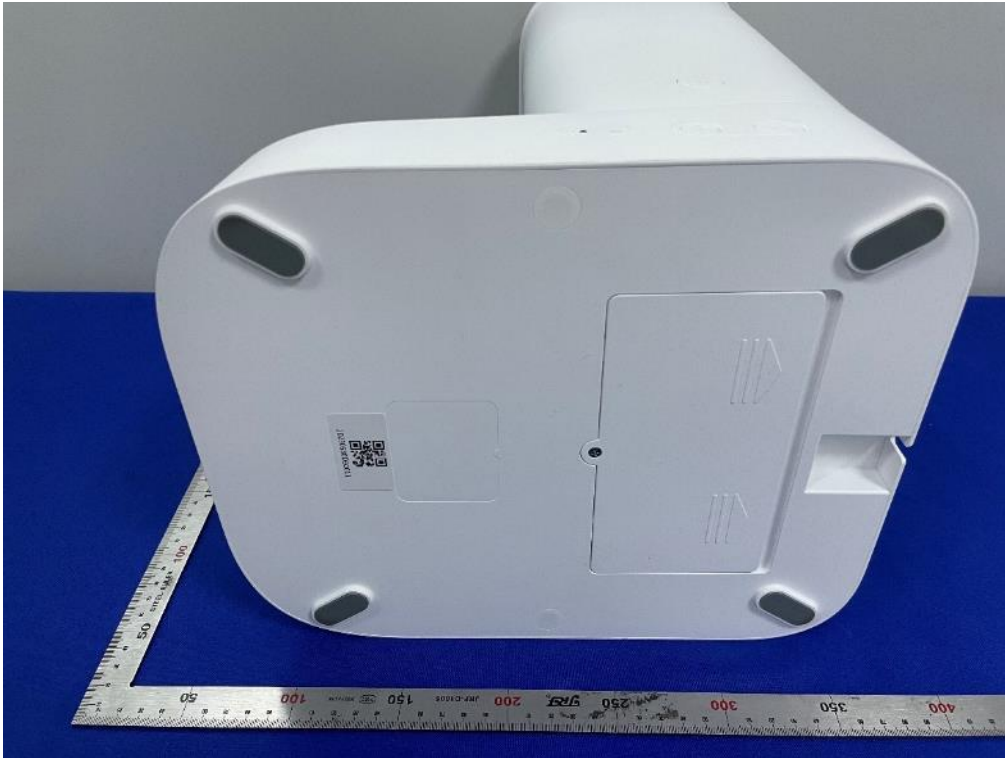

Bottom of the sample



Left of the sample

TEST REPORT

Report No.:

SHE23060039-04AE

Date:

2023-07-22

Page 32 of 38



Right of the sample



Open of the sample

TEST REPORT

Report No.:

SHE23060039-04AE

Date:

2023-07-22

Page 33 of 38

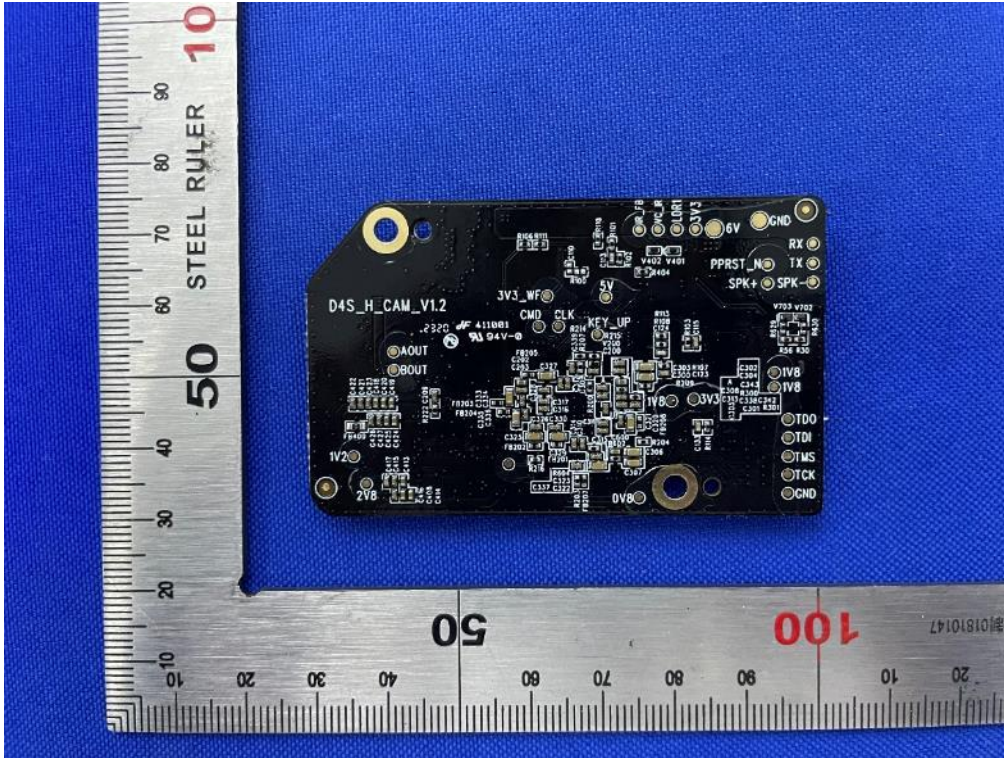

Internal-1 of the sample

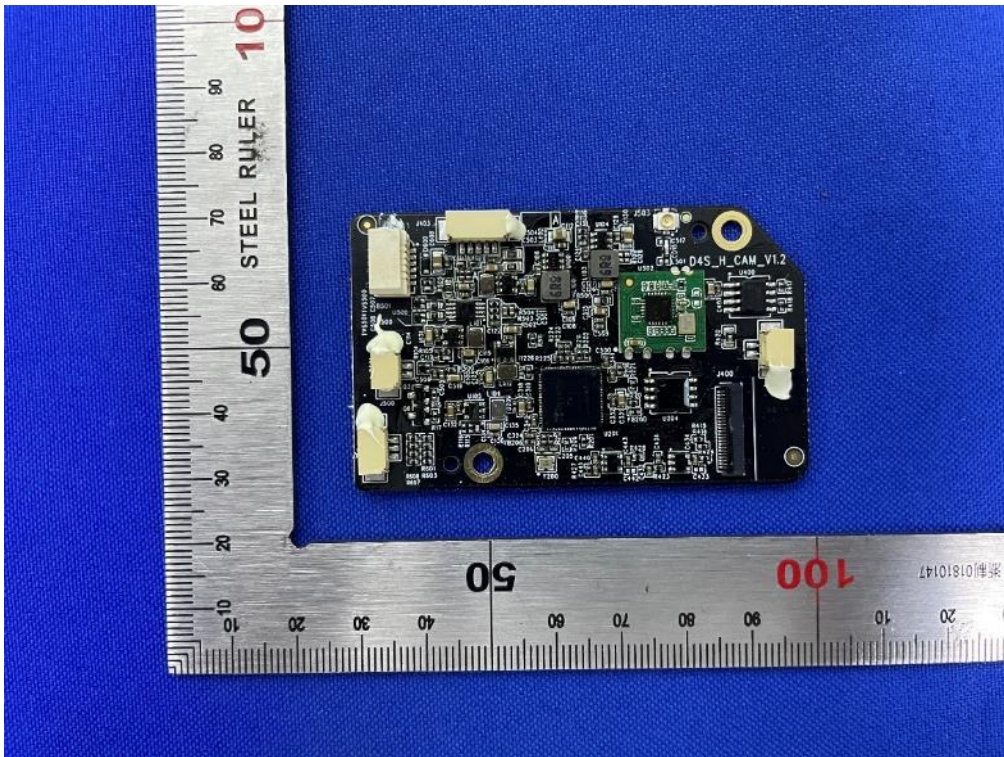

Internal-2 of the sample

TEST REPORT

Report No.:

SHE23060039-04AE

Date:

2023-07-22

Page 34 of 38



WIFI Antenna position

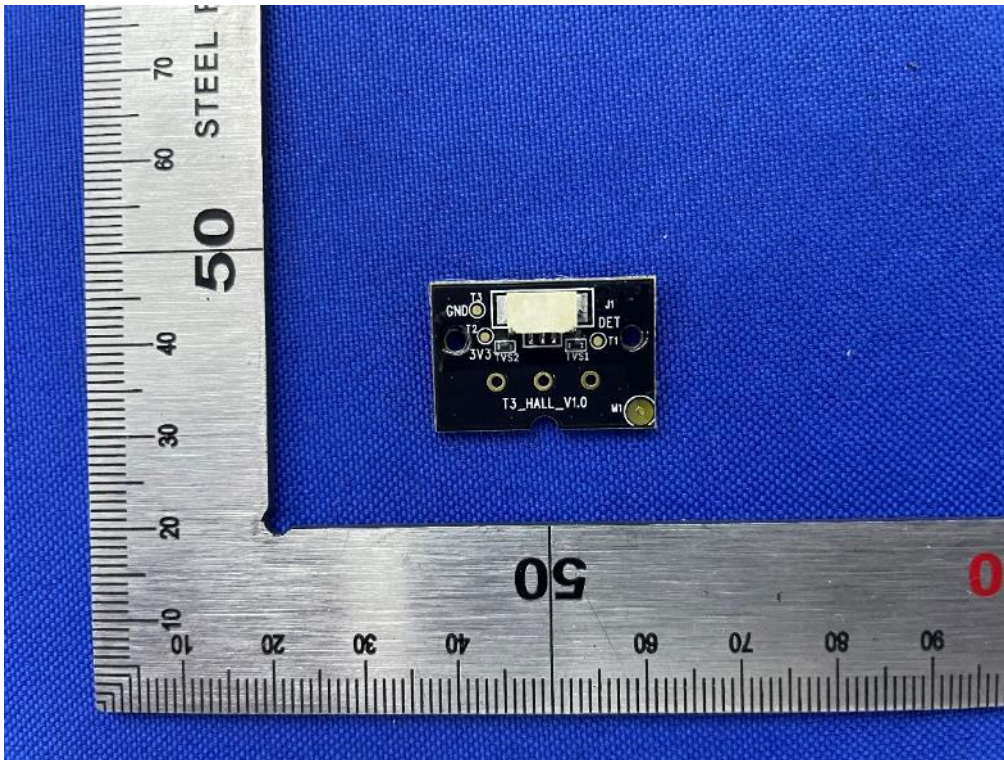

Internal-3 of the sample

TEST REPORT

Report No.:

SHE23060039-04AE

Date:

2023-07-22

Page 35 of 38

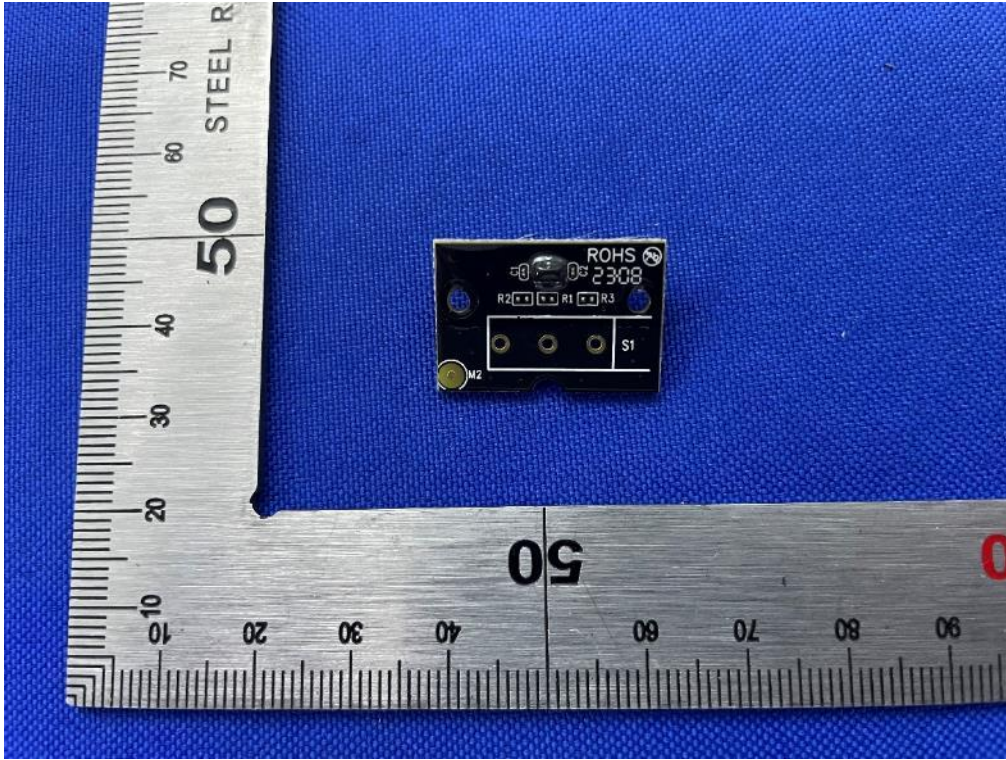

Internal-4 of the sample

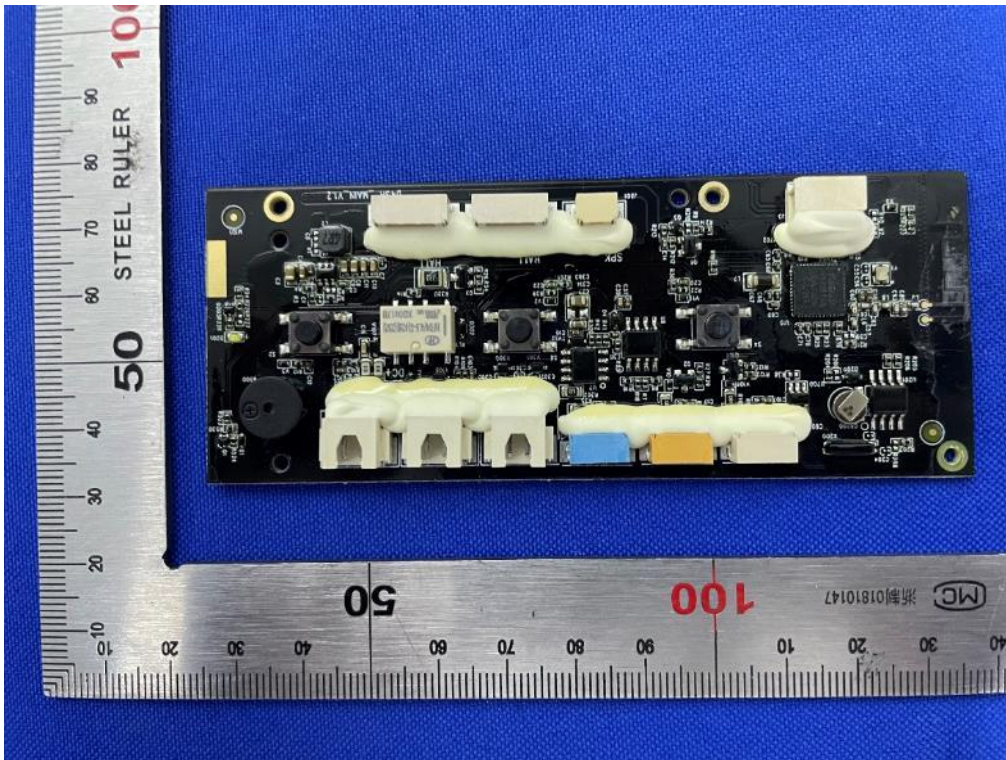

Internal-5 of the sample

TEST REPORT

Report No.:

SHE23060039-04AE

Date:

2023-07-22

Page 36 of 38

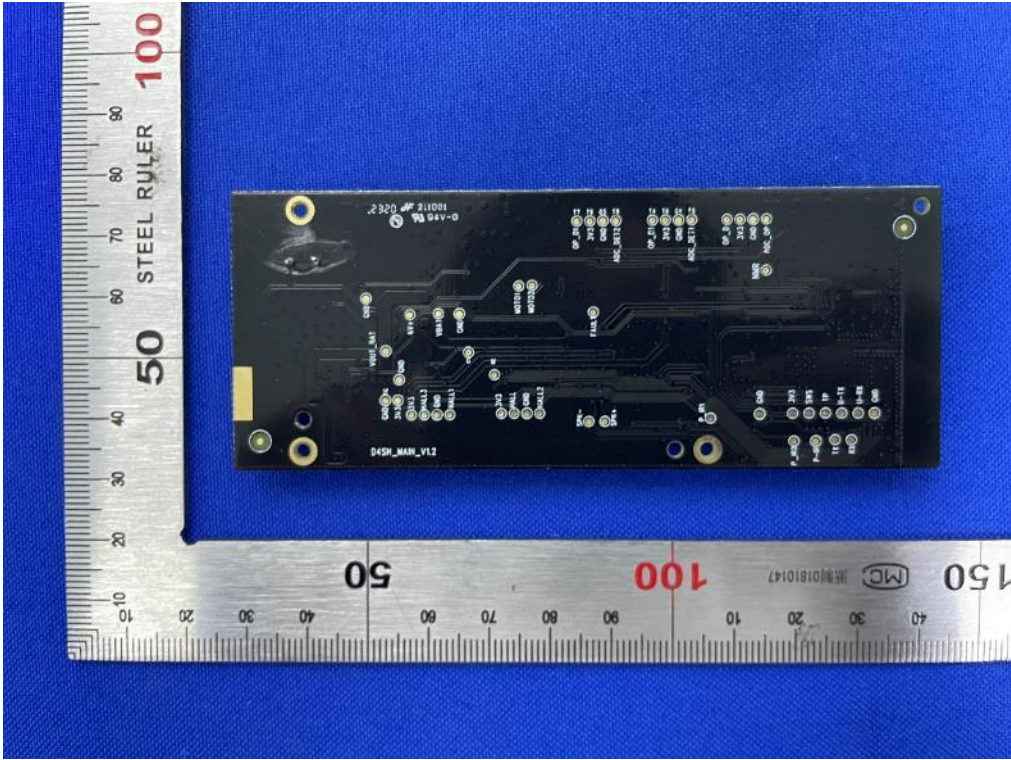

Internal-6 of the sample

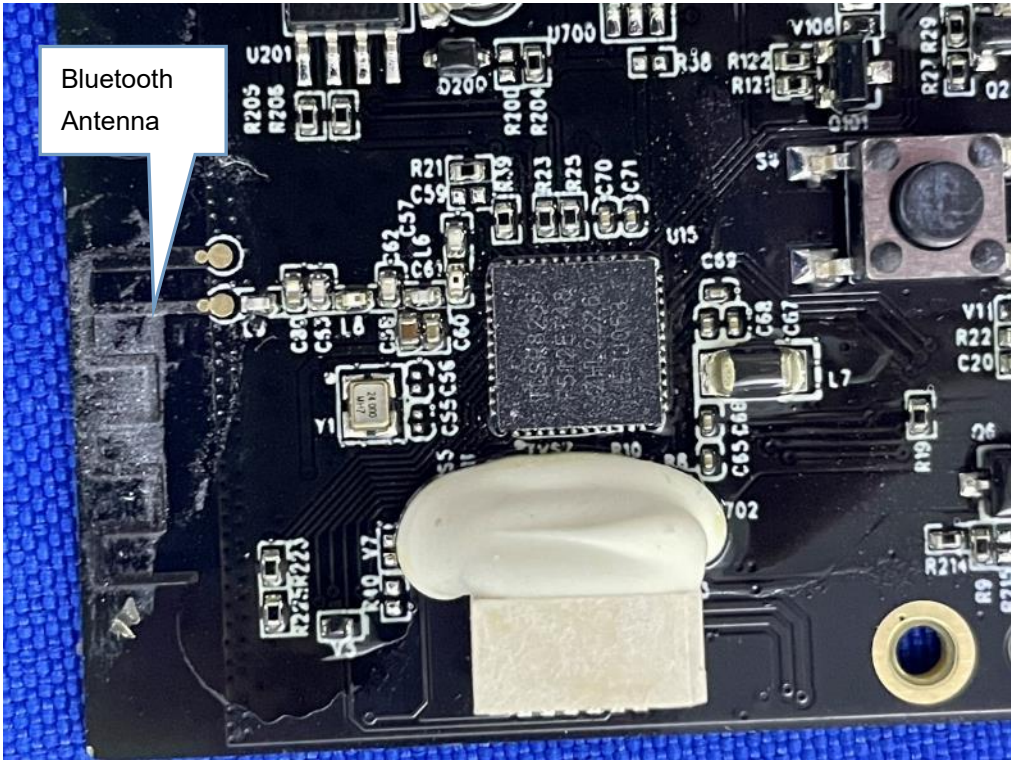

Bluetooth Antenna position

TEST REPORT

Report No.: SHE23060039-04AE

Date: 2023-07-22

Page 37 of 38

5.2 Set-up for Conducted Emissions



5.3 Set-up for Conducted RF test at Antenna Port



TEST REPORT

Report No.: SHE23060039-04AE

Date: 2023-07-22

Page 38 of 38

5.4 Set-up for Spurious Emissions below 1GHz

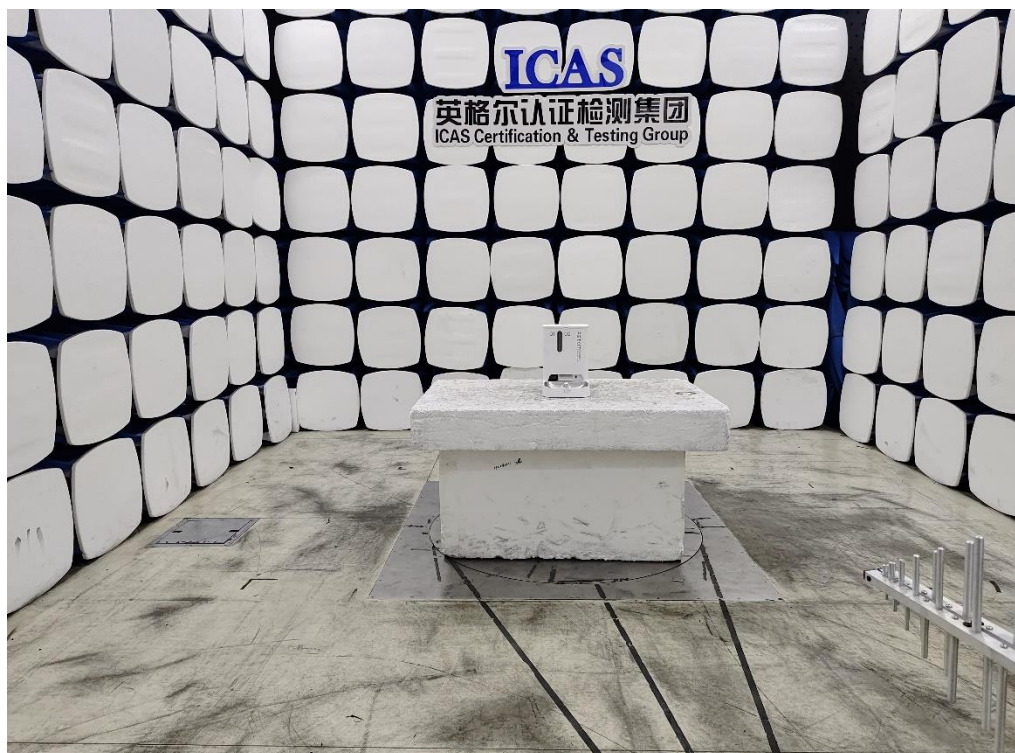

5.5 Set-up for Spurious Emissions above 1GHz



End of the report