

Test report

REP0027852-2TRFWL

Date of issue: March 15, 2023

Applicant:

TrellisWare Technologies, Inc

Product:

TW-950 with TW-1760 WIFI Dongle

Model:

TW-950 and TW-1760

Specifications:

- ◆ FCC 47 CFR Part 15, Subpart C – §15.207
Conducted limits
- ◆ FCC 47 CFR Part 15, Subpart C – §15.209
Radiated emission limits; general requirements

Lab and test locations

Company name	Nemko USA Inc.
Address	2210 Faraday Ave, Suite 150
City	Carlsbad
State	California
Postal code	92008
Country	USA
Telephone	+1 760 444 3500
Website	www.nemko.com
FCC Site Number	Test Firm Registration Number: 392943 Designation Number: US5058
ISED Test Site	2040B-3

Tested by	Chenhao Ma, Wireless test engineer
Reviewed by	James Cunningham, EMC/MIL/WL Supervisor
Review date	March 15, 2023
Reviewer signature	

Limits of responsibility

Note that the results contained in this report relate only to the items tested and were obtained in the period between the date of initial receipt of samples and the date of issue of the report.

This test report has been completed in accordance with the requirements of ISO/IEC 17025. All results contain in this report are within Nemko USA's ISO/IEC 17025 accreditation.

Copyright notification

Nemko USA Inc. authorizes the applicant to reproduce this report provided it is reproduced in its entirety and for use by the company's employees only. Any use which a third party makes of this report, or any reliance on or decisions to be made based on it, are the responsibility of such third parties.

Nemko USA Inc. accepts no responsibility for damages, if any, suffered by any third party as a result of decisions made or actions based on this report.

© Nemko USA Inc.

Table of Contents

- Table of Contents 3**
- Section 1 Report summary 4**
 - 1.1 Applicant..... 4
 - 1.2 Manufacture 4
 - 1.3 Test specifications 4
 - 1.4 Exclusions 4
 - 1.5 Test methods 4
 - 1.6 Statement of compliance..... 4
 - 1.7 Test report revision history..... 4
- Section 2 Summary of test results 5**
 - 2.1 Radiated and Conducted Emissions in simultaneous transmission..... 5
- Section 3 Equipment under test (EUT) details 6**
 - 3.1 Sample information 6
 - 3.2 EUT information 6
 - 3.3 EUT exercise and monitoring details 7
 - 3.4 EUT setup diagram..... 8
- Section 4 Engineering considerations 9**
 - 4.1 Modifications incorporated in the EUT..... 9
 - 4.2 Technical judgment 9
 - 4.3 Deviations from laboratory tests procedures 9
- Section 5 Test conditions 10**
 - 5.1 Atmospheric conditions..... 10
 - 5.2 Power supply range 10
- Section 6 Measurement uncertainty 11**
 - 6.1 Uncertainty of measurement 11
- Section 7 Test Equipment..... 12**
- Section 8 Testing data 13**
 - 8.1 Radiated emission limits; Intentional Radiators..... 13
 - 8.2 Conducted limits..... 28
- Section 9 Block diagrams of test set-ups..... 32**
 - 9.1 Radiated emissions set-up 32
 - 9.2 Conducted emissions set-up..... 33

Section 1 Report summary

1.1 Applicant

Company name	
Address	
City	
State	
Postal/Zip code	
Country	

1.2 Manufacture

Company name	
Address	
City	
State	
Postal/Zip code	
Country	

1.3 Test specifications

FCC 47 CFR Part 15, Subpart C – §15.207	Conducted limits.
FCC 47 CFR Part 15, Subpart C – §15.209	Radiated emission limits; general requirements.

1.4 Exclusions

None

1.5 Test methods

ANSI C63.10-2013	American National Standard of Procedures for Compliance Testing of Unlicensed Wireless Devices
------------------	--

1.6 Statement of compliance

In the configuration tested, the EUT was found compliant.

Testing was performed against all relevant requirements of the test standard except as noted in section 1.3 above. Results obtained indicate that the product under test complies in full with the requirements tested. The test results relate only to the items tested.

See "Summary of test results" for full details.

1.7 Test report revision history

Table 1.7-1: Test report revision history

Revision #	Details of changes made to test report
REP0027852-2TRFWL	Original report issue
Notes:	None

Section 2 Summary of test results

2.1 Radiated and Conducted Emissions in simultaneous transmission.

Table 2.1-1: FCC 47 CFR Part 15, Subpart C §15.207 & §15.209

Test description	Verdict
FCC 15.209 - Radiated disturbance	Pass
FCC 15.207 - Conducted disturbance	Pass

Notes: Test conducted disturbance while battery is charging

Section 3 Equipment under test (EUT) details

3.1 Sample information

Receipt date	January 25, 2023
Nemko sample ID number	PRJ0027852

3.2 EUT information

Product name	TW-950 TSM Shadow Radio and TW-1760 WIFI Dongle
Model	TW-950, TW-1760
Variant(s)	NA
Serial number	TW-950 = SN-189015, TW-1760 = None
Part number	TW-950 = ASY0750270, TW-1760 = None
Power requirements	TW-1450 32Wh Rechargeable Battery Slimline
Description/theory of operation	TW-950: Handheld MANET radio carries voice, location, and user data. User selectable channel bandwidth of 1.2, 3.6, 10, and 20MHz. TW-1760: WIFI dongle 4 channel (802.11 a/b/g/n)
Operational frequencies	TW-950: 2403 – 2478 MHz, depending on bandwidth selected, TW-1760: 2.4 GHz and 5 GHz depending on channel selected.
Software details	Version 6.2.1-b38
Operating band	2.4GHz and 5GHz
Test frequencies	2404MHz
Modulation type(s)	TSM, HDR
Antenna type	Omnidirectional antenna
Antenna gain (declared)	5 dBi
Nominal channel spacing	1 MHz

3.3 EUT exercise and monitoring details

Microchip's test tool was provided to change WLAN channels and data rates, with the module operating in test mode.

Satellite 'per' scripts were provided to exercise transmission on selected satellite channels and supported bearer types with the modem operating in test mode.

Table 3.3-1: EUT sub assemblies

Description	Brand name	Model/Part number	Serial number	Rev.
TW-950	TSM Shadow Radio	P/N ASY0750270	SN-189015	F
TW-1760	WIFI Dongle	TW-1760	NA	NA
TW-1147	Antenna, 1250-2700MHz, 5dBi	TW-1147	NA	A
TW-1450	Battery, 32Wh twist on Slimline	P/N ASY0570800	0114433	A

Table 3.3-2: EUT interface ports

Description	Qty.
RF Interface = TNC	1
Alignment Pin	1
GPS Interface = SMA	1
Power = 4 pin twist on battery bracket	1
Voice and Data = 12 pin ODU circular connector	1
Side Mutli-Function Connector (MFC) = 36 pin screw in with locating pin	1

Table 3.3-3: Support equipment

Description	Brand name	Model/Part number	Serial number	Rev.
Test Laptop	Dell	Latitude 7430	NA	NA

Table 3.3-4: Inter-connection cables

Cable description	From	To	Length (m)
TW-1670 USB Type-A to ADP Adapter	Test Laptop	Top Cap Audio/Data Connector	0.3
TW-1712 Ethernet Pigtail Dongle	Test Laptop	Side MFC Data Connector	1

3.4 EUT setup diagram

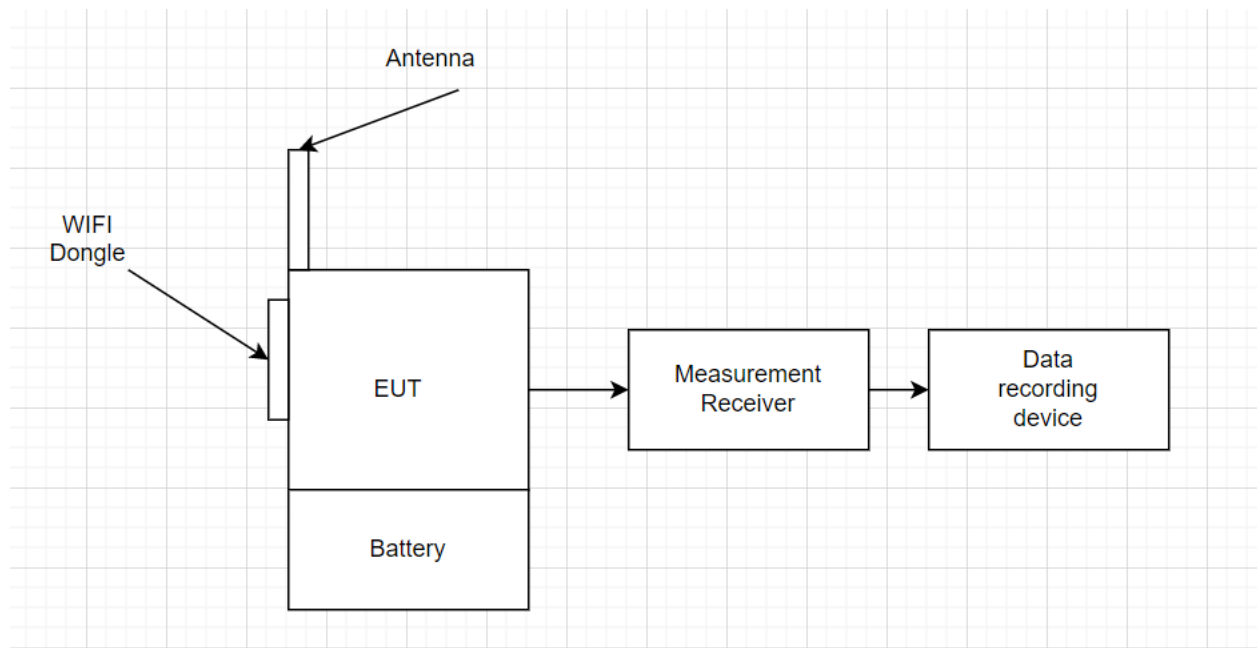

Figure 3.4-1: Setup diagram

Section 4 Engineering considerations

4.1 Modifications incorporated in the EUT

There were no modifications performed to the EUT during this assessment.

4.2 Technical judgment

None

4.3 Deviations from laboratory tests procedures

No deviations were made from laboratory procedures.

Section 5 Test conditions

5.1 Atmospheric conditions

Temperature	15–30 °C
Relative humidity	20–75 %
Air pressure	86–106 kPa

When it is impracticable to carry out tests under these conditions, a note to this effect stating the ambient temperature and relative humidity during the tests shall be recorded and stated.

5.2 Power supply range

The normal test voltage for equipment to be connected to the mains shall be the nominal mains voltage. For the purpose of the present document, the nominal voltage shall be the declared voltage, or any of the declared voltages $\pm 5\%$, for which the equipment was designed.

Section 6 Measurement uncertainty

6.1 Uncertainty of measurement

Nemko USA Inc. has calculated measurement uncertainty and is documented in EMC/MUC/001 “Uncertainty in EMC measurements.” Measurement uncertainty was calculated using the methods described in CISPR 16-4-2 Specification for radio disturbance and immunity measuring apparatus and methods – Part 4-2: Uncertainties, statistics, and limit modelling – Measurement instrumentation uncertainty. The expression of Uncertainty in EMC testing. Measurement uncertainty calculations assume a coverage factor of $K=2$ with 95% certainty.

Table 6.1-1: Measurement uncertainty calculations

Measurement		U_{cispr} dB	U_{lab} dB
Conducted disturbance at AC mains and other port power using a V-AMN	9 kHz to 150 kHz	3.8	2.9
	150 kHz to 30 MHz	3.4	2.3
Conducted disturbance at telecommunication port using AAN	150 kHz to 30 MHz	5.0	4.3
Conducted disturbance at telecommunication port using CVP	150 kHz to 30 MHz	3.9	2.9
Conducted disturbance at telecommunication port using CP	150 kHz to 30 MHz	2.9	1.4
Conducted disturbance at telecommunication port using CP and CVP	150 kHz to 30 MHz	4.0	3.1
Radiated disturbance (electric field strength in a SAC)	30 MHz to 1 GHz	6.3	5.5
Radiated disturbance (electric field strength in a FAR)	1 GHz to 6 GHz	5.2	4.7
Radiated disturbance (electric field strength in a FAR)	6 GHz to 18 GHz	5.5	5.0

Notes: Compliance assessment:

If U_{lab} is less than or equal to U_{cispr} then:

- compliance is deemed to occur if no measured disturbance level exceeds the disturbance limit;
- non-compliance is deemed to occur if any measured disturbance level exceeds the disturbance limit

If U_{lab} is greater than U_{cispr} then:

- compliance is deemed to occur if no measured disturbance level, increased by $(U_{\text{lab}} - U_{\text{cispr}})$, exceeds the disturbance limit;
- non-compliance is deemed to occur if any measured disturbance level, increased by $(U_{\text{lab}} - U_{\text{cispr}})$, exceeds the disturbance limit

V-AMN: V type artificial mains network

AAN: Asymmetric artificial network

CP: Current probe

CVP: Capacitive voltage probe

SAC: Semi-anechoic chamber

FAR: Fully anechoic room

Section 7 Test Equipment

Table 7.1-1: Test Equipment List

Equipment	Manufacturer	Model no.	Asset no.	Cal cycle	Next cal.
EMI Test Receiver	Rohde & Schwarz	ESCI 7	E1026	03/22/2022	03/22/2023
Standard Gain Horn Antenna	Eravant	SAZ-2410-42-S1	EW107	11/22/2022	11/22/2023
Transient Limiter	Hewlett-Packard	11947A	E1159	02/18/2022	02/18/2023
Two Line V-Network	Rohde & Schwarz	ENV216	E1019	09/30/2022	09/30/2023
EMI Test Receiver	Rohde & Schwarz	ESU40	E1121	05/31/2022	05/31/2023
System Controller	Sunol Sciences	SC104V	E1129	NCR	NCR
Bilog Antenna	Schaffner	CBL 6111D	1763	04/01/2022	04/01/2024
DRG Horn	ETS-Lindgren	3117-PA	E1139	04/19/2021	04/19/2023
Pre-Amp as part of DRG Horn	ETS-Lindgren	3117-PA	Part of E1139	04/19/2021	04/19/2023

Notes: NCR - no calibration required

Table 7.1-2: Test Software

Manufacturer of Software	Details
Rohde & Schwarz	EMC 32 V10.20.01 (AC conducted emissions)
Rohde & Schwarz	EMC 32 V10.60.15 (radiated emissions)

Notes: None

Section 8 Testing data

8.1 Radiated emission limits; Intentional Radiators.

8.1.1 References

Title 47 → Chapter I → Subchapter A → Part 15 → Subpart C → §15.209 / ANSI C63.4: 2014

- (a) Except as provided elsewhere in this subpart, the emissions from an intentional radiator shall not exceed the field strength levels specified in the following table:

(b)

Frequency (MHz)	Field strength (microvolts/meter)	Measurement distance (meters)
0.009-0.490	2400/F(kHz)	300
0.490-1.705	24000/F(kHz)	30
1.705-30.0	30	30
30-88	100**	3
88-216	150**	3
216-960	200**	3
Above 960	500	3

**Except as provided in paragraph (g), fundamental emissions from intentional radiators operating under this section shall not be located in the frequency bands 54-72 MHz, 76-88 MHz, 174-216 MHz or 470-806 MHz, however, operation within these frequency bands is permitted under other sections of this part, e.g., §§15.231 and 15.241.

- (c) In the emission table above, the tighter limit applies at the band edges.
- (d) The level of any unwanted emissions from an intentional radiator operating under these general provisions shall not exceed the level of the fundamental emission. For intentional radiators which operate under the provisions of other sections within this part and which are required to reduce their unwanted emissions to the limits specified in this table, the limits in this table are based on the frequency of the unwanted emission and not the fundamental frequency. However, the level of any unwanted emissions shall not exceed the level of the fundamental frequency.
- (e) The emission limits shown in the above table are based on measurements employing a CISPR quasi-peak detector except for the frequency bands 9-90 kHz, 110-490 kHz and above 1000 MHz. Radiated emission limits in these three bands are based on measurements employing an average detector.
- (f) The provisions in §§15.31, 15.33, and 15.35 for measuring emissions at distances other than the distances specified in the above table, determining the frequency range over which radiated emissions are to be measured, and limiting peak emissions apply to all devices operated under this part.
- (g) In accordance with §15.33(a), in some cases the emissions from an intentional radiator must be measured to beyond the tenth harmonic of the highest fundamental frequency designed to be emitted by the intentional radiator because of the incorporation of a digital device. If measurements above the tenth harmonic are so required, the radiated emissions above the tenth harmonic shall comply with the general radiated emission limits applicable to the incorporated digital device, as shown in §15.109 and as based on the frequency of the emission being measured, or, except for emissions contained in the restricted frequency bands shown in §15.205, the limit on spurious emissions specified for the intentional radiator, whichever is the higher limit. Emissions which must be measured above the tenth harmonic of the highest fundamental frequency designed to be emitted by the intentional radiator and which fall within the restricted bands shall comply with the general radiated emission limits in §15.109 that are applicable to the incorporated digital device.

8.1.2 Test summary

Verdict	Pass		
Test date	February 16, 2023	Temperature	22.1 °C
Test engineer	Chenhao Ma, Wireless test engineer	Air pressure	998.2 mbar
Test location	3m semi anechoic chamber	Relative humidity	41.7 %

8.1.3 Notes

In order to investigate the spectrum from the lowest radio frequency signal generated in the device to the tenth harmonic of the highest fundamental frequency, per 47 CFR § 15.33 (a)-1, radiated emissions were measured from 30 MHz to 26.5 GHz.

8.1.4 Setup details

EUT setup configuration	Table top
Test facility	3 m Semi anechoic chamber
Measuring distance	3 m
Antenna height variation	1–4 m
Turn table position	0–360°
Measurement details	A preview measurement was generated with receiver in continuous scan or sweep mode while the EUT was rotated and antenna adjusted to maximize radiated emission. Emissions detected within 6 dB or above limit were re-measured with the appropriate detector against the correlating limit and recorded as the final measurement.

Receiver/spectrum analyzer settings for frequencies below 1 GHz:

Resolution bandwidth	120 kHz
Video bandwidth	300 kHz
Detector mode	– Peak (Preview measurement) – Quasi-peak (Final measurement)
Trace mode	Max Hold
Measurement time	– 100 ms (Peak preview measurement) – 5000 ms (Quasi-peak final measurement)

Receiver/spectrum analyzer settings for frequencies above 1 GHz:

Resolution bandwidth	1 MHz
Video bandwidth	3 MHz
Detector mode	Peak (Preview measurement) Peak and CAverage (Final measurement)
Trace mode	Max Hold
Measurement time	– 100 ms (Peak preview measurement) – 5000 ms (Peak and CAverage final measurement)

8.1.5 Setup details, continued

Table 8.1-1: Radiated disturbance equipment list

Equipment	Manufacturer	Model no.	Asset no.	Cal cycle	Next cal.
EMI Test Receiver	Rohde & Schwarz	ESU40	E1121	1 year	05/31/2023
Standard Gain Horn Antenna	Eravant	SAZ-2410-42-S1	EW107	1 year	11/22/2023
System Controller	Sunol Sciences	SC104V	E1129	NCR	NCR
Bilog Antenna	Schaffner	CBL 6111D	1763	2 years	04/01/2024
DRG Horn	ETS-Lindgren	3117-PA	E1139	2 years	04/19/2023
Pre-Amp as part of DRG Horn	ETS-Lindgren	3117-PA	Part of E1139	2 years	04/19/2023

Notes: NCR - no calibration required

Table 8.1-2: Radiated disturbance test software details

Manufacturer of Software	Details
Rohde & Schwarz	EMC 32 V10.60.15

Notes: None

8.1.6 Test data Radiated Emissions 30MHz-18GHz (Satellite and WLAN modules transmitting simultaneously)

Full Spectrum

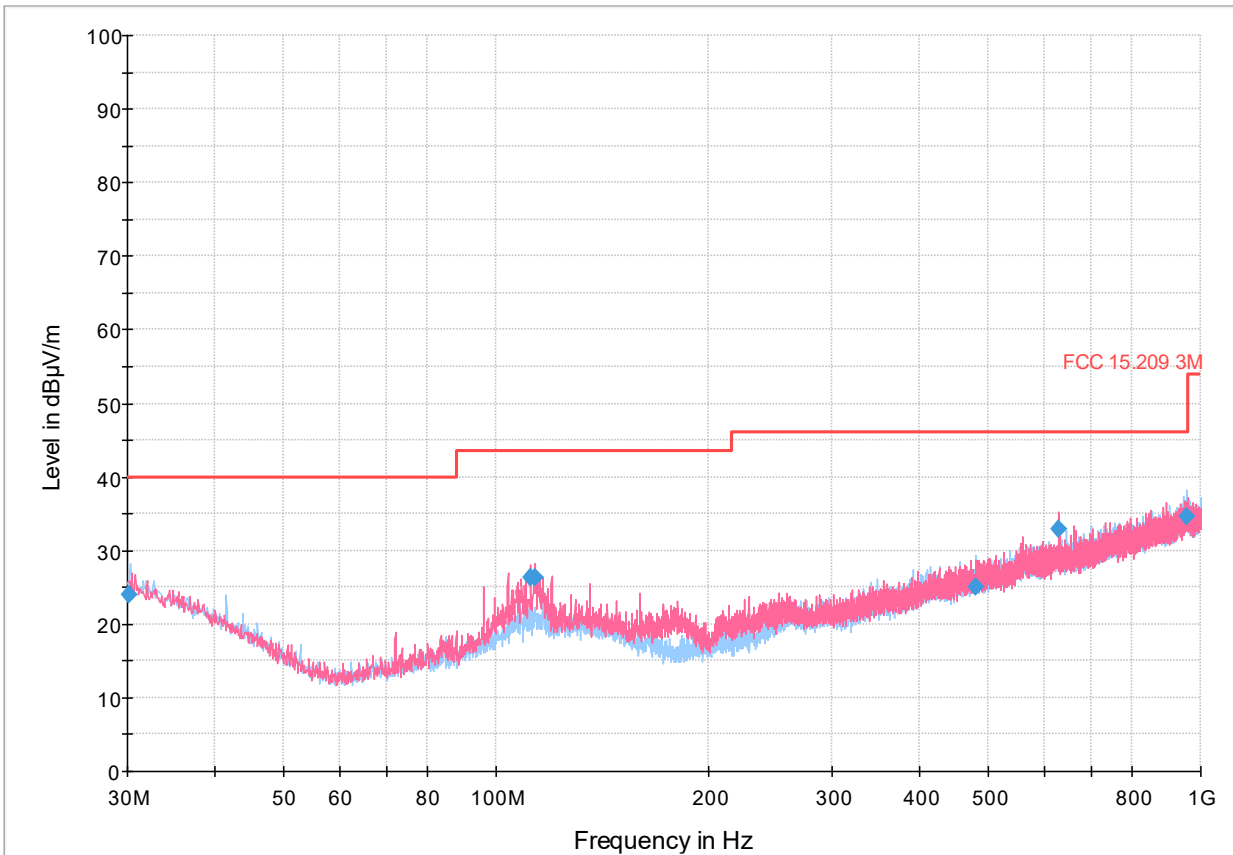

Figure 8.1-3: Radiated emission TSM-30-1000MHz-2404-BW4-TW950 Wi-Fi channel b

Frequency (MHz)	QuasiPeak (dBµV/m)	Limit (dBµV/m)	Margin (dB)	Meas. Time (ms)	Bandwidth (kHz)	Height (cm)	Pol	Azimuth (deg)	Corr. (dB/m)
30.200000	23.92	40.00	16.08	5000.0	120.000	285.0	H	21.0	26.5
112.022000	26.37	43.50	17.13	5000.0	120.000	354.0	V	234.0	19.0
113.654000	26.30	43.50	17.20	5000.0	120.000	378.0	V	258.0	19.2
479.385000	25.10	46.00	20.90	5000.0	120.000	345.0	H	0.0	26.9
630.002000	33.00	46.00	13.00	5000.0	120.000	299.0	V	0.0	30.0
956.978000	34.65	46.00	11.35	5000.0	120.000	264.0	H	248.0	34.9

Table 8.1.3-Radiated field strength measurement results TSM-30-1000MHz-2404-BW4-TW950 Wi-Fi channel b

Full Spectrum

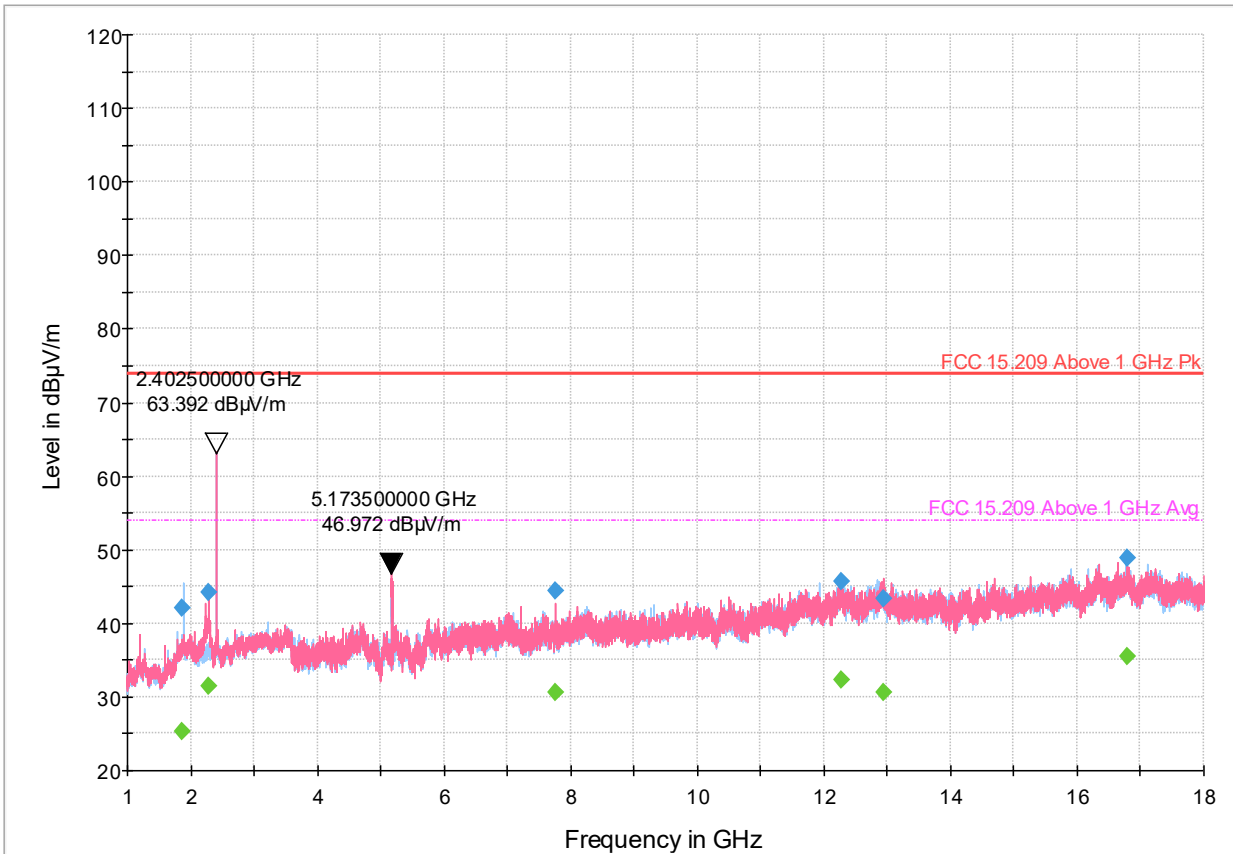

Figure 8.1-2: Radiated emission TSM-1-18GHz-2404-BW4-TW950 Wi-Fi channel a

Frequency (MHz)	MaxPeak (dBµV/m)	CAverage (dBµV/m)	Limit (dBµV/m)	Margin (dB)	Meas. Time (ms)	Bandwidth (kHz)	Height (cm)	Pol	Azimuth (deg)	Corr. (dB/m)
1875.855556	42.05	---	73.90	31.85	5000.0	1000.000	153.0	H	152.0	-10.8
1875.855556	---	25.38	53.90	28.52	5000.0	1000.000	153.0	H	152.0	-10.8
2283.900000	---	31.43	53.90	22.47	5000.0	1000.000	166.0	V	108.0	-10.7
2283.900000	44.26	---	73.90	29.64	5000.0	1000.000	166.0	V	108.0	-10.7
7770.433333	---	30.66	53.90	23.24	5000.0	1000.000	166.0	V	79.0	1.1
7770.433333	44.33	---	73.90	29.57	5000.0	1000.000	166.0	V	79.0	1.1
12277.433333	45.67	---	73.90	28.23	5000.0	1000.000	202.0	V	0.0	7.1
12277.433333	---	32.36	53.90	21.54	5000.0	1000.000	202.0	V	0.0	7.1
12947.400000	---	30.57	53.90	23.33	5000.0	1000.000	159.0	V	126.0	8.6
12947.400000	43.36	---	73.90	30.54	5000.0	1000.000	159.0	V	126.0	8.6
16787.444444	---	35.42	53.90	18.48	5000.0	1000.000	249.0	H	274.0	14.6
16787.444444	48.97	---	73.90	24.93	5000.0	1000.000	249.0	H	274.0	14.6

Table 8.1.4-Radiated field strength measurement results TSM-1-18GHz-2404-BW4-TW950 Wi-Fi channel a

Full Spectrum

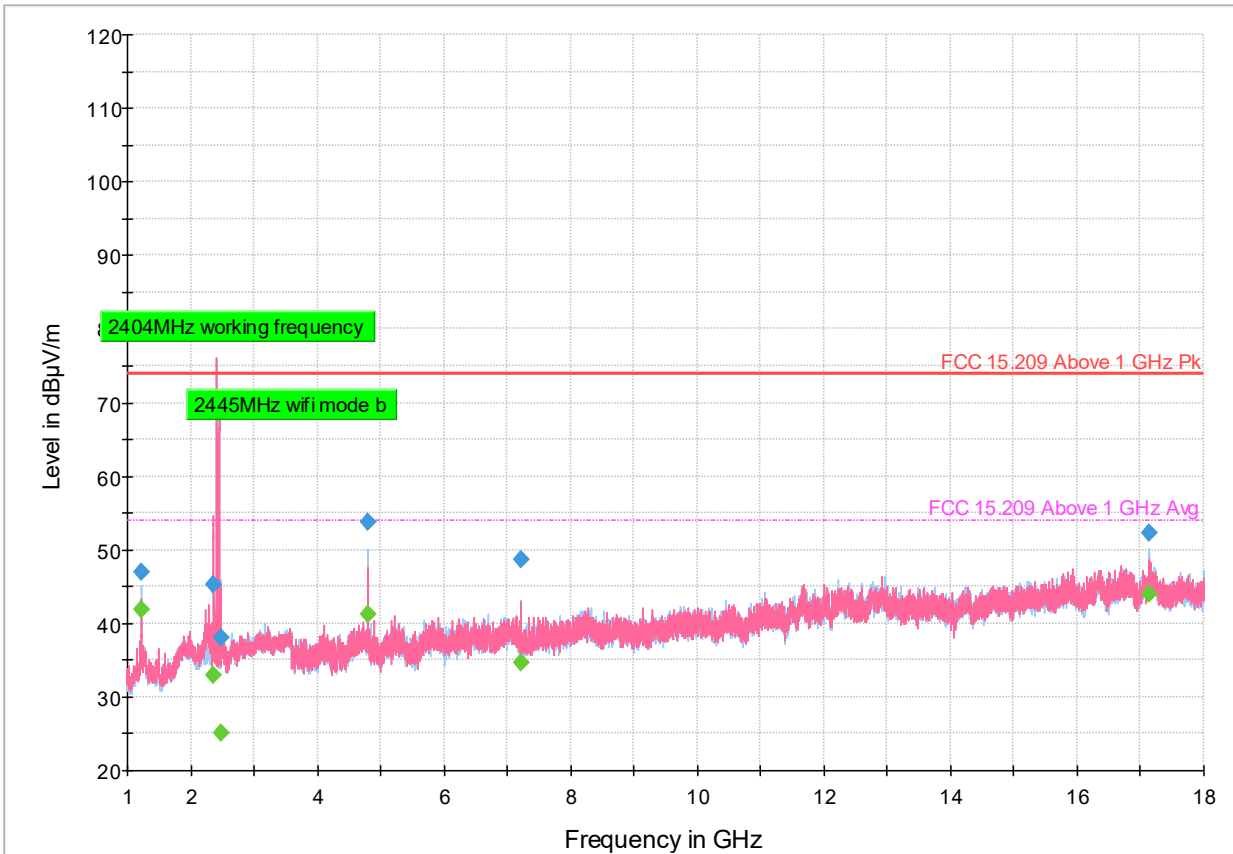

Figure 8.1-3: Radiated emission TSM-1-18GHz-2404-BW4-TW950 Wi-Fi channel b

Frequency (MHz)	MaxPeak (dBµV/m)	CAverage (dBµV/m)	Limit (dBµV/m)	Margin (dB)	Meas. Time (ms)	Bandwidth (kHz)	Height (cm)	Pol	Azimuth (deg)	Corr. (dB/m)
1223.688889	46.99	---	73.90	26.91	5000.0	1000.000	242.0	H	0.0	-13.7
1223.688889	---	41.97	53.90	11.93	5000.0	1000.000	242.0	H	0.0	-13.7
2358.511111	---	32.96	53.90	20.94	5000.0	1000.000	183.0	V	257.0	-10.1
2358.511111	45.29	---	73.90	28.61	5000.0	1000.000	183.0	V	257.0	-10.1
2491.133333	---	25.13	53.90	28.77	5000.0	1000.000	245.0	H	88.0	-9.6
2491.133333	38.15	---	73.90	35.75	5000.0	1000.000	245.0	H	88.0	-9.6
4805.855556	---	41.32	53.90	12.58	5000.0	1000.000	195.0	H	337.0	-2.3
4805.855556	53.78	---	73.90	20.12	5000.0	1000.000	195.0	H	337.0	-2.3
7214.844444	48.64	---	73.90	25.26	5000.0	1000.000	121.0	V	10.0	0.3
7214.844444	---	34.75	53.90	19.15	5000.0	1000.000	121.0	V	10.0	0.3
17128.055556	---	44.07	53.90	9.83	5000.0	1000.000	182.0	H	52.0	13.9
17128.055556	52.18	---	73.90	21.72	5000.0	1000.000	182.0	H	52.0	13.9

Table 8.1.5-Radiated field strength measurement results TSM-1-18GHz-2404-BW4-TW950 Wi-Fi channel b

Full Spectrum

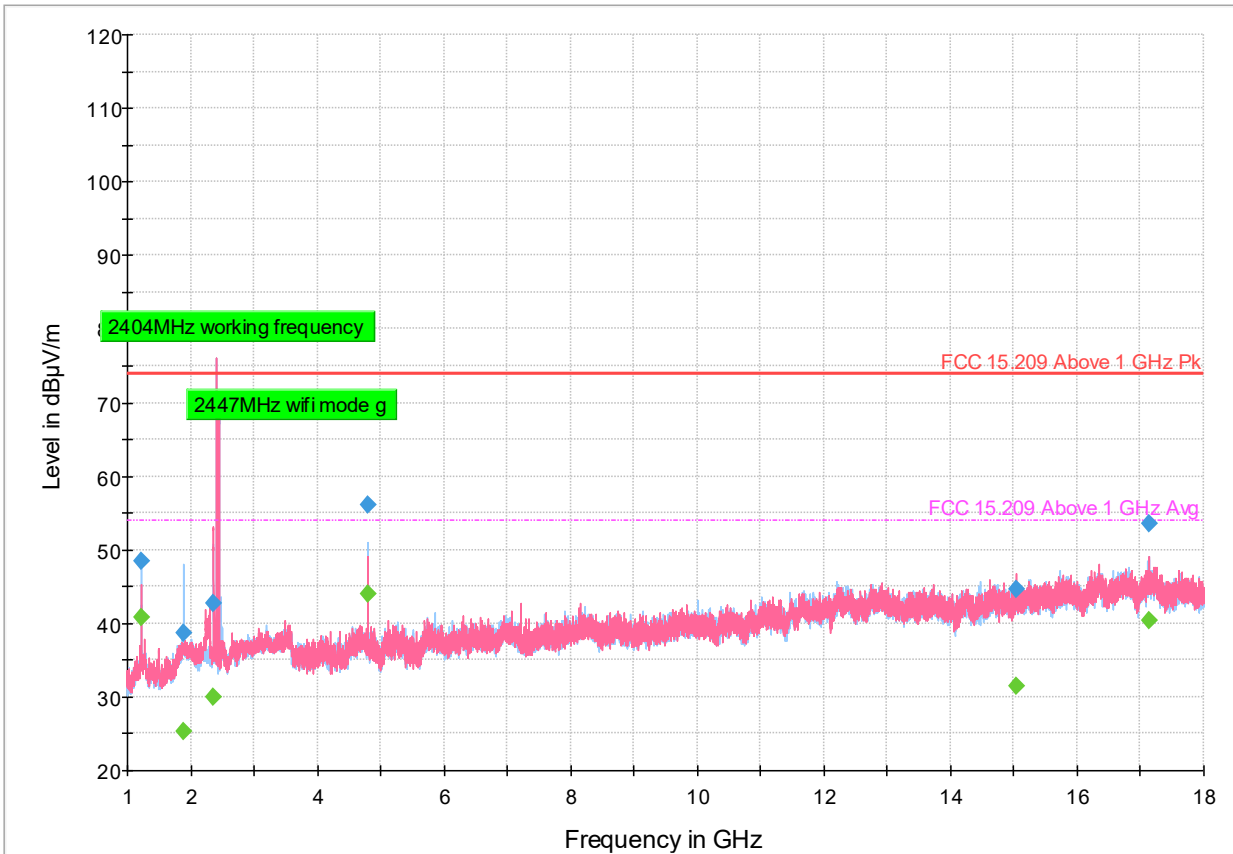

Figure 8.1-4: Radiated emission TSM-1-18GHz-2404-BW4-TW950 Wi-Fi channel g

Frequency (MHz)	MaxPeak (dBµV/m)	CAverage (dBµV/m)	Limit (dBµV/m)	Margin (dB)	Meas. Time (ms)	Bandwidth (kHz)	Height (cm)	Pol	Azimuth (deg)	Corr. (dB/m)
1223.288889	48.43	---	73.90	25.47	5000.0	1000.000	238.0	H	0.0	-13.7
1223.288889	---	40.89	53.90	13.01	5000.0	1000.000	238.0	H	0.0	-13.7
1883.055556	38.69	---	73.90	35.21	5000.0	1000.000	283.0	H	300.0	-10.7
1883.055556	---	25.29	53.90	28.61	5000.0	1000.000	283.0	H	300.0	-10.7
2358.033333	---	29.90	53.90	24.00	5000.0	1000.000	147.0	V	349.0	-10.1
2358.033333	42.74	---	73.90	31.16	5000.0	1000.000	147.0	V	349.0	-10.1
4809.855556	---	43.90	53.90	10.00	5000.0	1000.000	194.0	H	20.0	-2.3
4809.855556	56.06	---	73.90	17.84	5000.0	1000.000	194.0	H	20.0	-2.3
15031.566667	---	31.49	53.90	22.41	5000.0	1000.000	189.0	V	250.0	10.5
15031.566667	44.60	---	73.90	29.30	5000.0	1000.000	189.0	V	250.0	10.5
17131.000000	---	40.48	53.90	13.42	5000.0	1000.000	192.0	H	64.0	14.0
17131.000000	53.47	---	73.90	20.43	5000.0	1000.000	192.0	H	64.0	14.0

Table 8.1.6-Radiated field strength measurement results TSM-1-18GHz-2404-BW4-TW950 Wi-Fi channel g

Full Spectrum

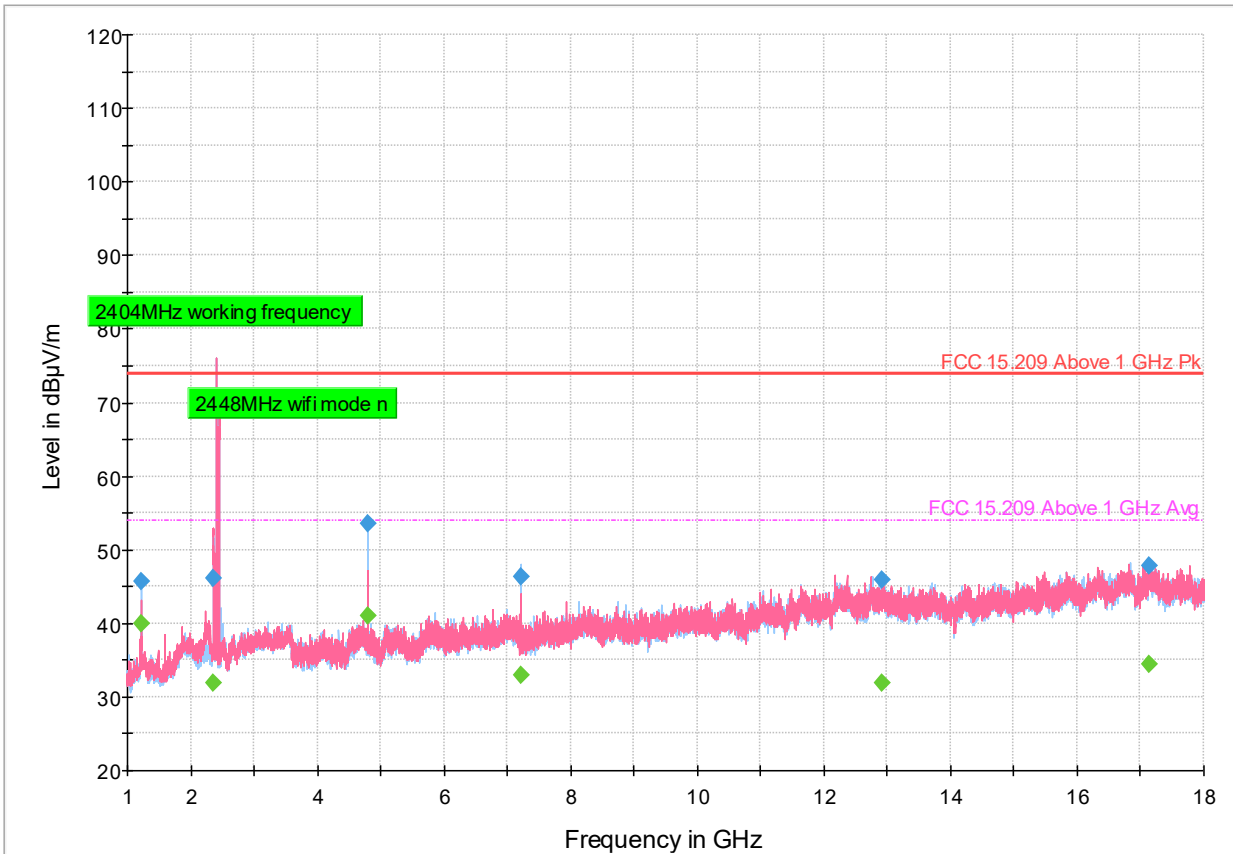

Figure 8.1-5: Radiated emission TSM-1-18GHz-2404-BW4-TW950 Wi-Fi channel n

Frequency (MHz)	MaxPeak (dBµV/m)	CAverage (dBµV/m)	Limit (dBµV/m)	Margin (dB)	Meas. Time (ms)	Bandwidth (kHz)	Height (cm)	Pol	Azimuth (deg)	Corr. (dB/m)
1223.688889	45.72	---	73.90	28.18	5000.0	1000.000	240.0	H	322.0	-13.7
1223.688889	---	39.99	53.90	13.91	5000.0	1000.000	240.0	H	322.0	-13.7
2354.477778	46.18	---	73.90	27.72	5000.0	1000.000	170.0	V	241.0	-10.1
2354.477778	---	31.86	53.90	22.04	5000.0	1000.000	170.0	V	241.0	-10.1
4809.966667	53.56	---	73.90	20.34	5000.0	1000.000	192.0	H	343.0	-2.3
4809.966667	---	40.93	53.90	12.97	5000.0	1000.000	192.0	H	343.0	-2.3
7211.977778	46.43	---	73.90	27.47	5000.0	1000.000	167.0	H	43.0	0.4
7211.977778	---	32.93	53.90	20.97	5000.0	1000.000	167.0	H	43.0	0.4
12921.177778	45.93	---	73.90	27.97	5000.0	1000.000	310.0	V	252.0	8.6
12921.177778	---	31.99	53.90	21.91	5000.0	1000.000	310.0	V	252.0	8.6
17136.222222	47.87	---	73.90	26.03	5000.0	1000.000	195.0	V	102.0	14.1
17136.222222	---	34.41	53.90	19.49	5000.0	1000.000	195.0	V	102.0	14.1

Table 8.1.7-Radiated field strength measurement results TSM-1-18GHz-2404-BW4-TW950 Wi-Fi channel n

Full Spectrum

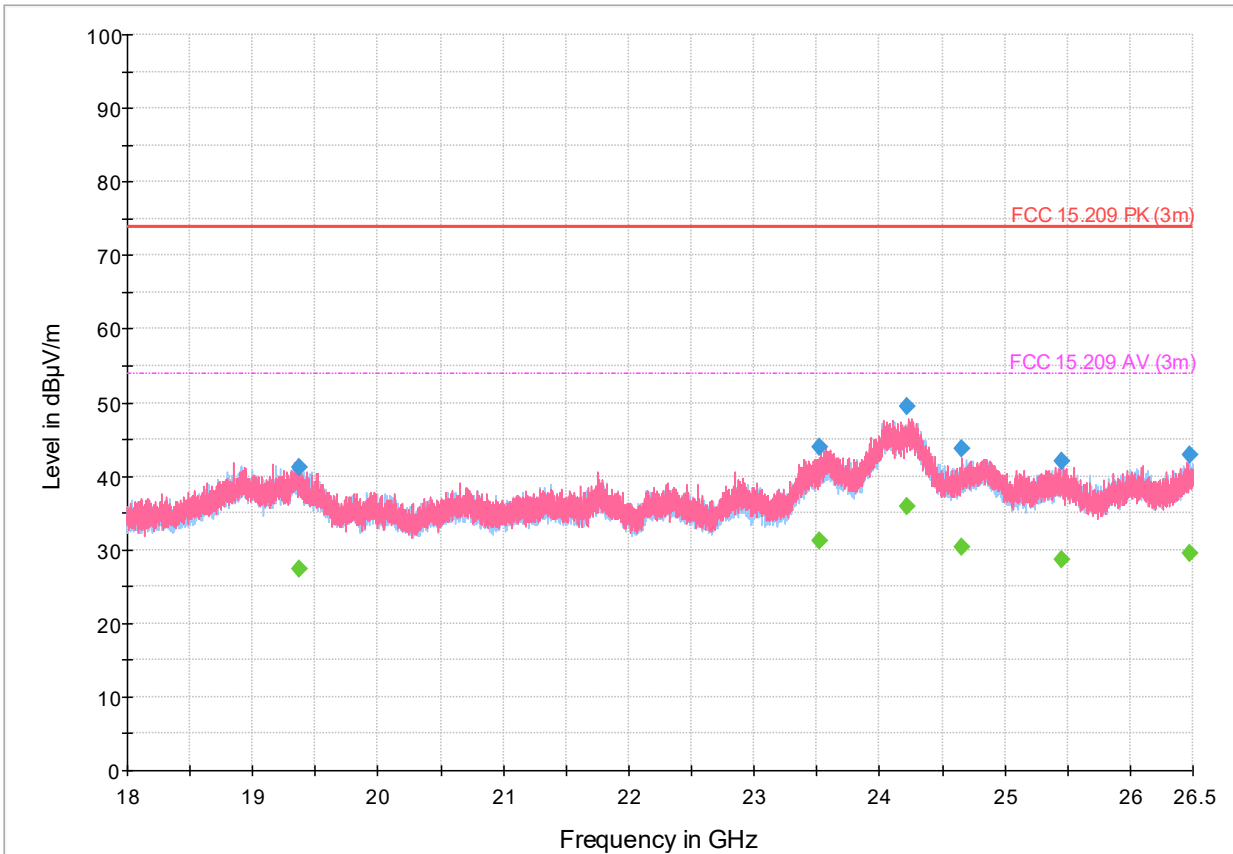

Figure 8.1-6: Radiated emission TSM-18-26.5GHz-2404-BW4-TW950 Wi-Fi channel a

Frequency (MHz)	MaxPeak (dBµV/m)	CAverage (dBµV/m)	Limit (dBµV/m)	Margin (dB)	Meas. Time (ms)	Bandwidth (kHz)	Height (cm)	Pol	Azimuth (deg)	Corr. (dB/m)
19366.206250	41.18	---	73.90	32.72	5000.0	1000.000	212.0	H	90.0	16.7
19366.206250	---	27.48	53.90	26.42	5000.0	1000.000	212.0	H	90.0	16.7
23523.162500	44.00	---	73.90	29.90	5000.0	1000.000	282.0	V	68.0	23.3
23523.162500	---	31.12	53.90	22.78	5000.0	1000.000	282.0	V	68.0	23.3
24219.106250	49.57	---	73.90	24.33	5000.0	1000.000	309.0	V	33.0	27.0
24219.106250	---	35.79	53.90	18.11	5000.0	1000.000	309.0	V	33.0	27.0
24651.718750	43.70	---	73.90	30.20	5000.0	1000.000	302.0	V	33.0	22.5
24651.718750	---	30.30	53.90	23.60	5000.0	1000.000	302.0	V	33.0	22.5
25455.112500	---	28.74	53.90	25.16	5000.0	1000.000	170.0	H	32.0	21.8
25455.112500	42.11	---	73.90	31.79	5000.0	1000.000	170.0	H	32.0	21.8
26470.050000	---	29.41	53.90	24.49	5000.0	1000.000	134.0	H	91.0	23.3
26470.050000	42.94	---	73.90	30.96	5000.0	1000.000	134.0	H	91.0	23.3

Table 8.1.8-Radiated field strength measurement results TSM-18-26.5GHz-2404-BW4-TW950 Wi-Fi channel a

Full Spectrum

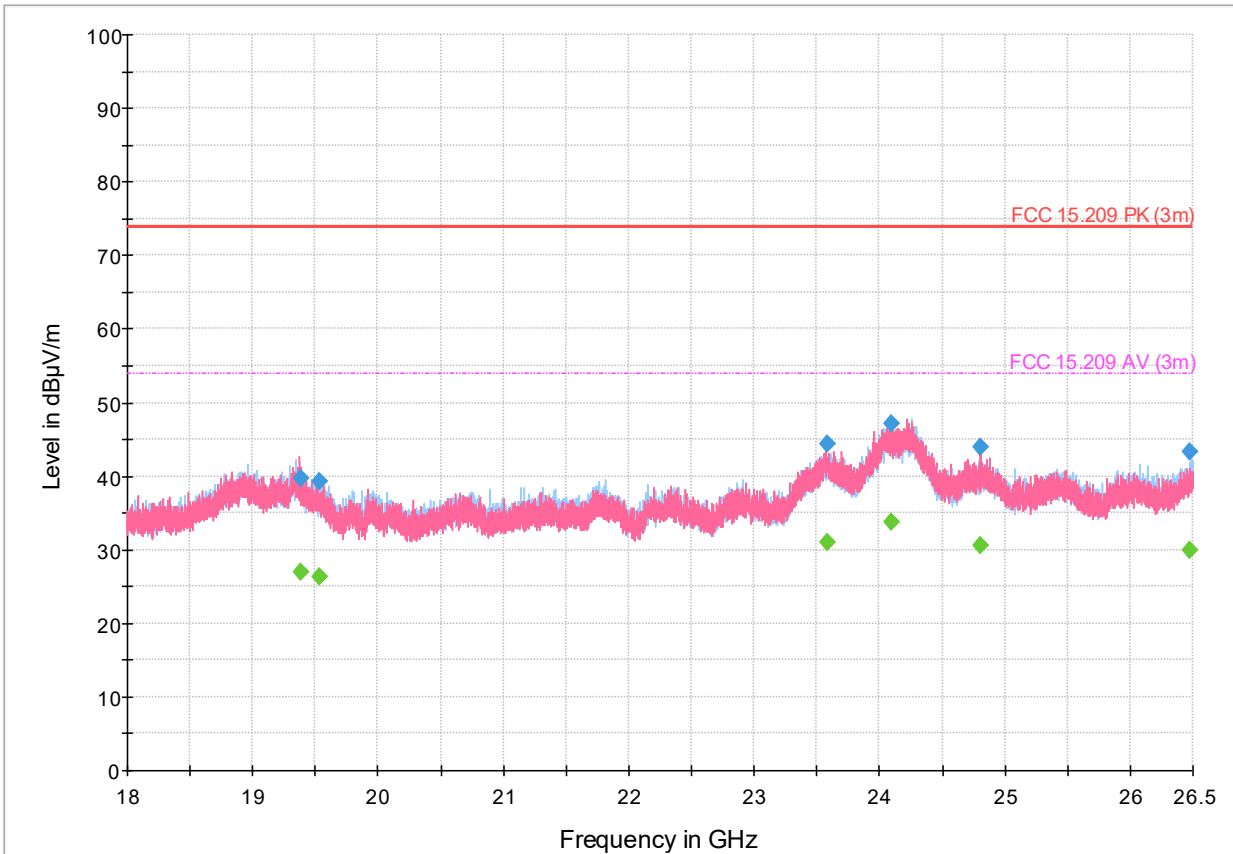

Figure 8.1-7: Radiated emission TSM-18-26.5GHz-2404-BW4-TW950 Wi-Fi channel b

Frequency (MHz)	MaxPeak (dBµV/m)	CAverage (dBµV/m)	Limit (dBµV/m)	Margin (dB)	Meas. Time (ms)	Bandwidth (kHz)	Height (cm)	Pol	Azimuth (deg)	Corr. (dB/m)
19377.200000	---	26.88	53.90	27.02	5000.0	1000.000	334.0	V	355.0	16.6
19377.200000	39.73	---	73.90	34.17	5000.0	1000.000	334.0	V	355.0	16.6
19534.050000	---	26.39	53.90	27.51	5000.0	1000.000	276.0	H	0.0	16.3
19534.050000	39.34	---	73.90	34.56	5000.0	1000.000	276.0	H	0.0	16.3
23581.531250	44.35	---	73.90	29.55	5000.0	1000.000	248.0	V	207.0	23.9
23581.531250	---	30.99	53.90	22.91	5000.0	1000.000	248.0	V	207.0	23.9
24090.568750	---	33.81	53.90	20.09	5000.0	1000.000	400.0	H	349.0	27.4
24090.568750	47.21	---	73.90	26.69	5000.0	1000.000	400.0	H	349.0	27.4
24803.512500	---	30.47	53.90	23.43	5000.0	1000.000	322.0	V	351.0	22.3
24803.512500	43.88	---	73.90	30.02	5000.0	1000.000	322.0	V	351.0	22.3
26478.931250	43.32	---	73.90	30.58	5000.0	1000.000	135.0	H	327.0	23.3
26478.931250	---	30.03	53.90	23.87	5000.0	1000.000	135.0	H	327.0	23.3

Table 8.1.9-Radiated field strength measurement results TSM-18-26.5GHz-2404-BW4-TW950 Wi-Fi channel b

Full Spectrum

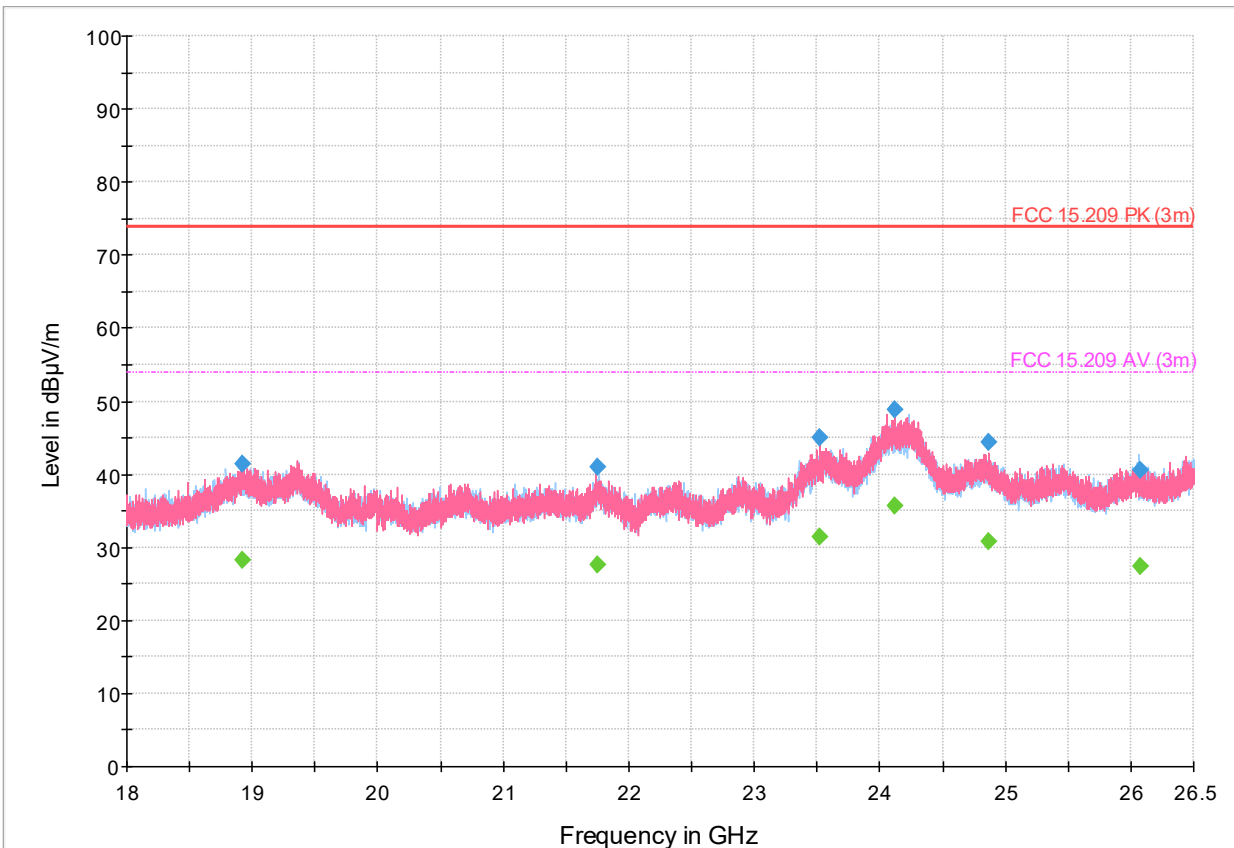

Figure 8.1-8: Radiated emission TSM-18-26.5GHz-2404-BW4-TW950 Wi-Fi channel g

Frequency (MHz)	MaxPeak (dBµV/m)	CAverage (dBµV/m)	Limit (dBµV/m)	Margin (dB)	Meas. Time (ms)	Bandwidth (kHz)	Height (cm)	Pol	Azimuth (deg)	Corr. (dB/m)
18916.306250	41.45	---	73.90	32.45	5000.0	1000.000	114.0	H	240.0	15.9
18916.306250	---	28.15	53.90	25.75	5000.0	1000.000	114.0	H	240.0	15.9
21749.393750	---	27.59	53.90	26.31	5000.0	1000.000	290.0	V	272.0	17.5
21749.393750	40.91	---	73.90	32.99	5000.0	1000.000	290.0	V	272.0	17.5
23527.462500	---	31.32	53.90	22.58	5000.0	1000.000	227.0	V	78.0	23.4
23527.462500	44.99	---	73.90	28.91	5000.0	1000.000	227.0	V	78.0	23.4
24114.343750	---	35.71	53.90	18.19	5000.0	1000.000	289.0	V	275.0	27.4
24114.343750	48.93	---	73.90	24.97	5000.0	1000.000	289.0	V	275.0	27.4
24869.006250	---	30.75	53.90	23.15	5000.0	1000.000	134.0	V	265.0	22.3
24869.006250	44.45	---	73.90	29.45	5000.0	1000.000	134.0	V	265.0	22.3
26070.956250	40.57	---	73.90	33.33	5000.0	1000.000	336.0	H	102.0	21.9
26070.956250	---	27.47	53.90	26.43	5000.0	1000.000	336.0	H	102.0	21.9

Table 8.1.10-Radiated field strength measurement results TSM-18-26.5GHz-2404-BW4-TW950 Wi-Fi channel g

Full Spectrum

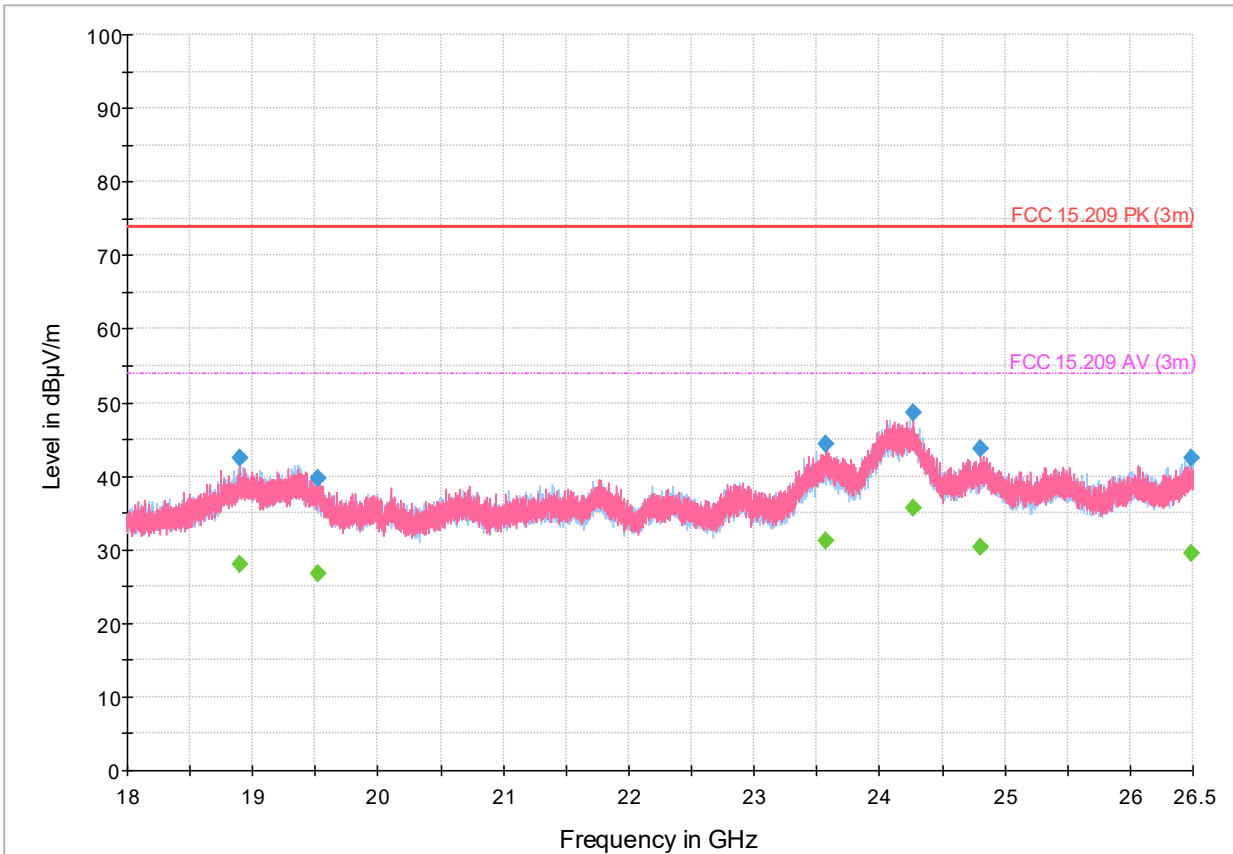

Figure 8.1-9: Radiated emission TSM-18-26.5GHz-2404-BW4-TW950 Wi-Fi channel n

Frequency (MHz)	MaxPeak (dBµV/m)	CAverage (dBµV/m)	Limit (dBµV/m)	Margin (dB)	Meas. Time (ms)	Bandwidth (kHz)	Height (cm)	Pol	Azimuth (deg)	Corr. (dB/m)
18896.693750	42.42	---	73.90	31.48	5000.0	1000.000	356.0	V	126.0	15.9
18896.693750	---	28.08	53.90	25.82	5000.0	1000.000	356.0	V	126.0	15.9
19515.212500	---	26.66	53.90	27.24	5000.0	1000.000	114.0	V	103.0	16.3
19515.212500	39.75	---	73.90	34.15	5000.0	1000.000	114.0	V	103.0	16.3
23567.006250	---	31.17	53.90	22.73	5000.0	1000.000	214.0	V	0.0	23.8
23567.006250	44.30	---	73.90	29.60	5000.0	1000.000	214.0	V	0.0	23.8
24264.037500	---	35.59	53.90	18.31	5000.0	1000.000	367.0	V	323.0	26.9
24264.037500	48.63	---	73.90	25.27	5000.0	1000.000	367.0	V	323.0	26.9
24808.593750	43.80	---	73.90	30.10	5000.0	1000.000	183.0	V	220.0	22.3
24808.593750	---	30.35	53.90	23.55	5000.0	1000.000	183.0	V	220.0	22.3
26490.200000	---	29.47	53.90	24.43	5000.0	1000.000	283.0	H	115.0	23.4
26490.200000	42.39	---	73.90	31.51	5000.0	1000.000	283.0	H	115.0	23.4

Table 8.1.11-Radiated field strength measurement results TSM-18-26.5GHz-2404-BW4-TW950 Wi-Fi channel n

8.1.7 Radiated Emissions Setup photos

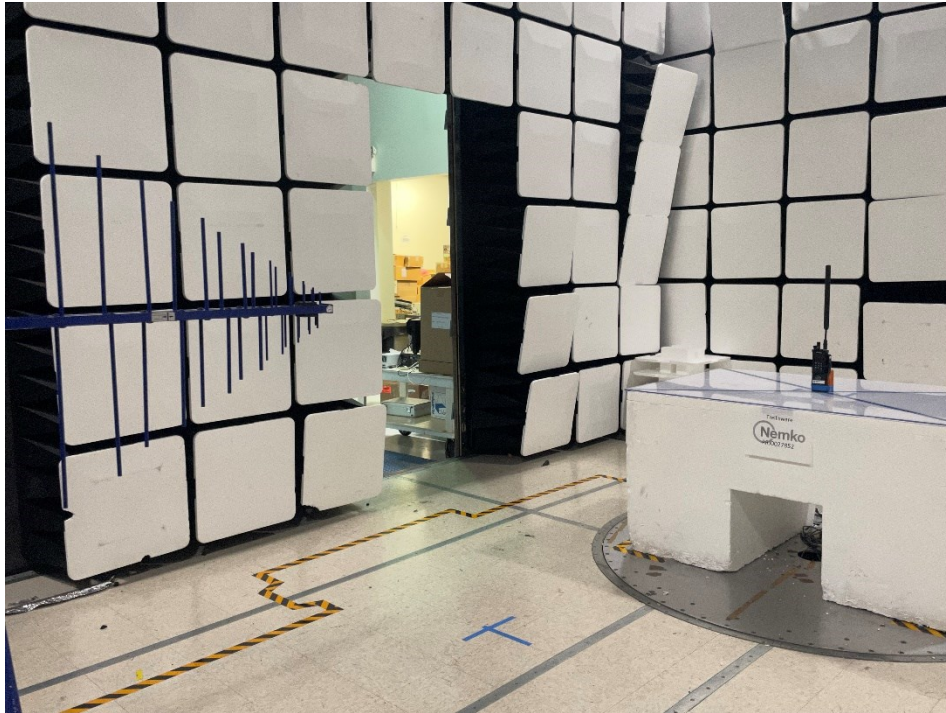

Figure 8.1.10 Radiated emissions 30-1000 MHz (Front)

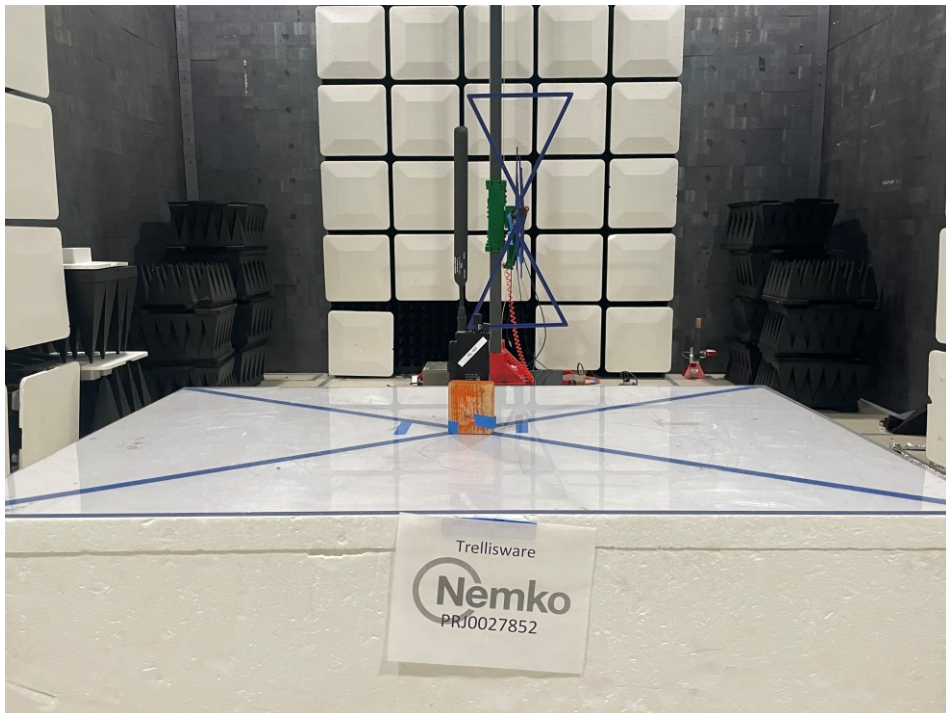

Figure 8.1.11 Radiated emissions 30-1000 MHz (Rear)

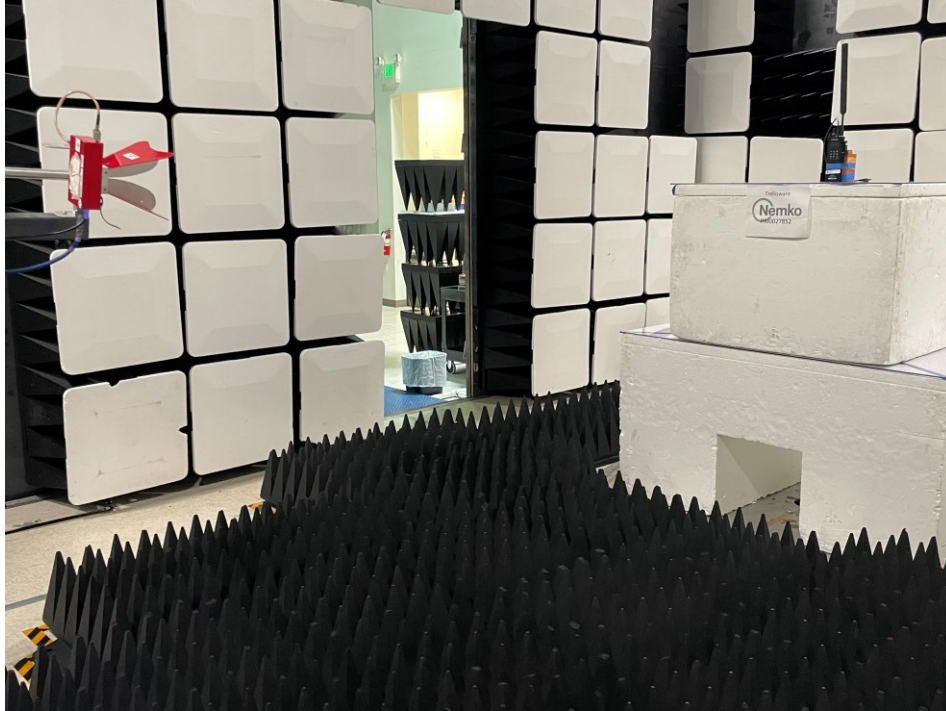

Figure 8.1.12 Radiated emissions 1-18 GHz (Front)

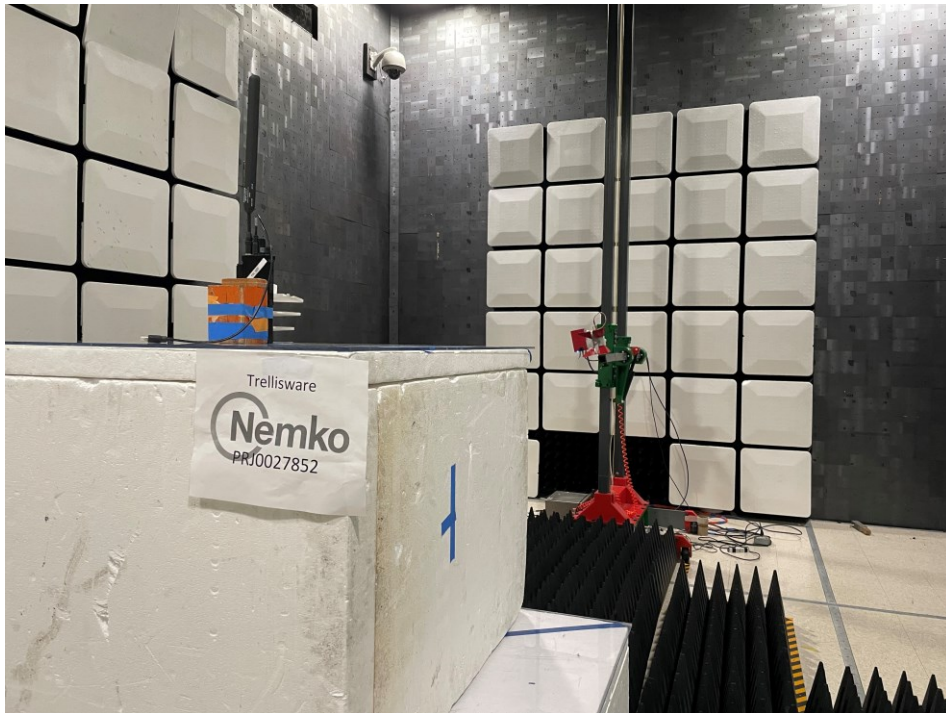

Figure 8.1.13 Radiated emissions 1-18 GHz (Rear)



Figure 8.1.14 Radiated emissions 18-26.5 GHz (Front)

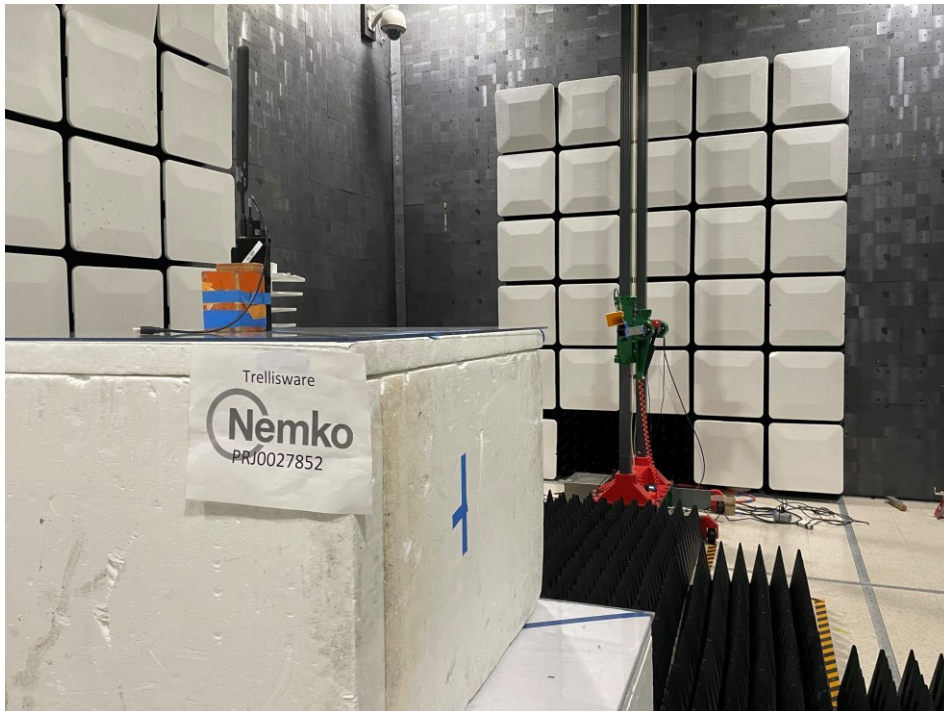

Figure 8.1.15 Radiated emissions 18-26.5 GHz (Rear)

8.2 Conducted limits.

8.2.1 References

Title 47 → Chapter I → Subchapter A → Part 15 → Subpart C → §15.207 / ANSI C63.4: 2014

- (a) Except as shown in paragraphs (b) and (c) of this section, for an intentional radiator that is designed to be connected to the public utility (AC) power line, the radio frequency voltage that is conducted back onto the AC power line on any frequency or frequencies, within the band 150 kHz to 30 MHz, shall not exceed the limits in the following table, as measured using a 50 μ H/50 ohms line impedance stabilization network (LISN). Compliance with the provisions of this paragraph shall be based on the measurement of the radio frequency voltage between each power line and ground at the power terminal. The lower limit applies at the boundary between the frequency ranges.

Frequency of emission (MHz)	Conducted limit (dB μ V)	
	Quasi-peak	Average
0.15-0.5	66 to 56*	56 to 46*
0.5-5	56	46
5-30	60	50

*Decreases with the logarithm of the frequency

- (b) The limit shown in paragraph (a) of this section shall not apply to carrier current systems operating as intentional radiators on frequencies below 30 MHz. In lieu thereof, these carrier current systems shall be subject to the following standards:
- For carrier current system containing their fundamental emission within the frequency band 535-1705 kHz and intended to be received using a standard AM broadcast receiver: no limit on conducted emissions.
 - For all other carrier current systems: 1000 μ V within the frequency band 535-1705 kHz, as measured using a 50 μ H/50 ohms LISN.
 - Carrier current systems operating below 30 MHz are also subject to the radiated emission limits in §15.205, §15.209, §15.221, §15.223, or §15.227, as appropriate.
- (c) Measurements to demonstrate compliance with the conducted limits are not required for devices which only employ battery power for operation and which do not operate from the AC power lines or contain provisions for operation while connected to the AC power lines. Devices that include, or make provisions for, the use of battery chargers which permit operating while charging, AC adapters or battery eliminators or that connect to the AC power lines indirectly, obtaining their power through another device which is connected to the AC power lines, shall be tested to demonstrate compliance with the conducted limits.

8.2.2 Conducted limits

Verdict	Pass		
Test date	February 16, 2023	Temperature	22.1 °C
Test engineer	Chenhao Ma, Wireless test engineer	Air pressure	998.2 mbar
Test location	Ground Plane	Relative humidity	41.7 %

8.2.3 Notes

Test while the EUT battery is charging

8.2.4 Setup details

Port under test	AC Mains Input
EUT setup configuration	Table top
Measurement details	A preview measurement was generated with the receiver in continuous scan mode. Emissions detected within 6 dB or above limit were re-measured with the appropriate detector against the correlating limit and recorded as the final measurement.

Receiver settings:

Resolution bandwidth	9 kHz
Video bandwidth	30 kHz
Detector mode	– Peak (Preview measurement) – Quasi-peak and CAverage (Final measurement)
Trace mode	Max Hold
Measurement time	– 100 ms (Peak preview measurement) – 5000 ms (Quasi-peak final measurement) – 5000 ms (CAverage final measurement)

Table 8.2-1: Conducted disturbance at mains port equipment list

Equipment	Manufacturer	Model no.	Asset no.	Cal cycle	Next cal.
EMI Test Receiver	Rohde & Schwarz	ESCI 7	E1026	1 year	03/22/2023
Transient Limiter	Hewlett-Packard	11947A	E1159	1 year	02/18/2023
Two Line V-Network	Rohde & Schwarz	ENV216	E1019	1 year	09/30/2023

Notes: None

Table 8.2-2: Conducted disturbance at mains port test software details

Manufacturer of Software	Details
Rohde & Schwarz	EMC 32 V10.20.01

Notes: None

8.2.5 Conducted Emissions Test data

Full Spectrum

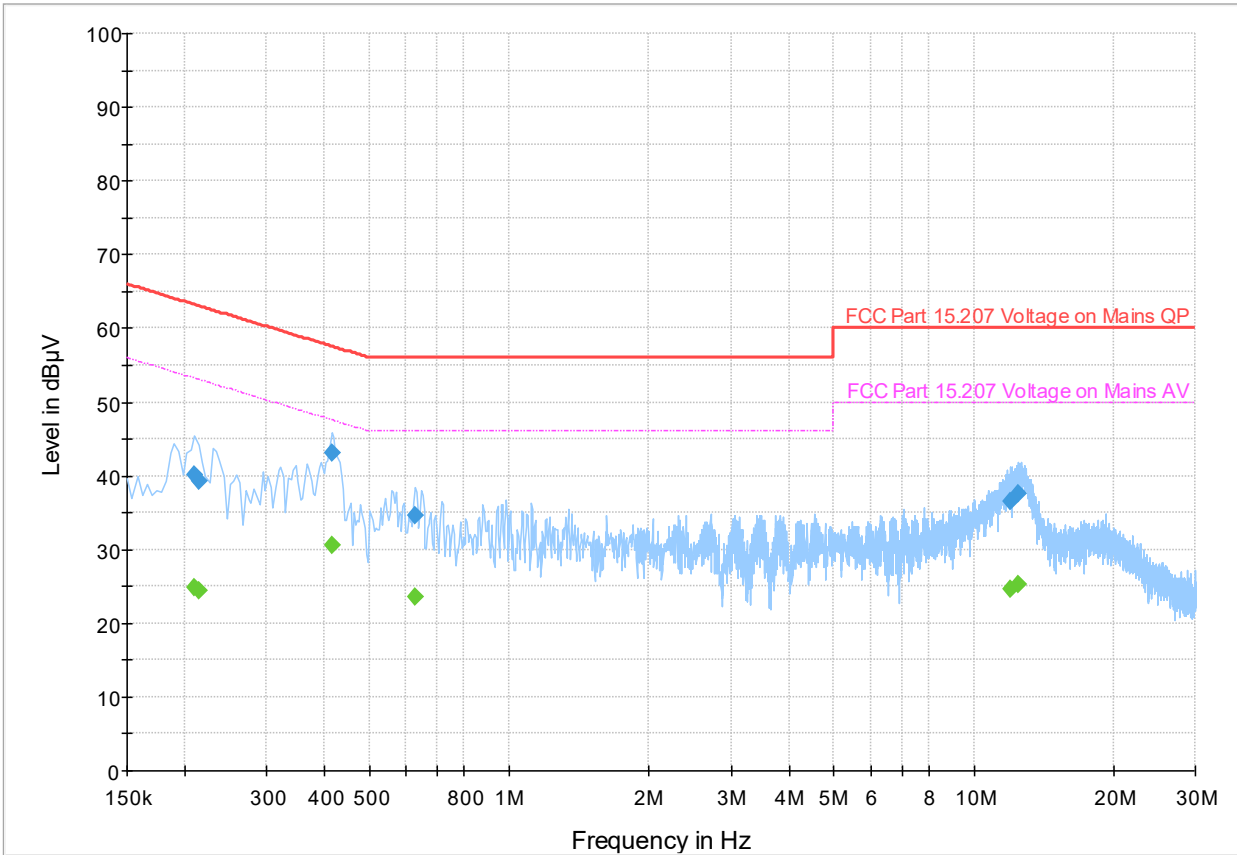

Figure 8.2.1: Conducted spurious emissions, 150 kHz-30 MHz

Frequency (MHz)	QuasiPeak (dBµV)	CAverage (dBµV)	Limit (dBµV)	Margin (dB)	Meas. Time (ms)	Bandwidth (kHz)	Line	Filter	Corr. (dB)
0.210000	40.06	---	63.21	23.15	5000.0	9.000	L1	ON	19.5
0.210000	---	24.89	53.21	28.32	5000.0	9.000	L1	ON	19.5
0.214000	39.19	---	63.05	23.86	5000.0	9.000	L1	ON	19.5
0.214000	---	24.47	53.05	28.58	5000.0	9.000	L1	ON	19.5
0.414000	43.12	---	57.57	14.45	5000.0	9.000	L1	ON	19.4
0.414000	---	30.62	47.57	16.95	5000.0	9.000	L1	ON	19.4
0.626000	34.71	---	56.00	21.29	5000.0	9.000	L1	ON	19.4
0.626000	---	23.47	46.00	22.53	5000.0	9.000	L1	ON	19.4
12.030000	36.42	---	60.00	23.58	5000.0	9.000	L1	ON	19.8
12.030000	---	24.59	50.00	25.41	5000.0	9.000	L1	ON	19.8
12.490000	37.53	---	60.00	22.47	5000.0	9.000	L1	ON	19.9
12.490000	---	25.35	50.00	24.65	5000.0	9.000	L1	ON	19.9

Table 8.2-3 Conducted disturbance at AC mains results (Quasi-Peak and Average)

8.2.6 Conducted Emissions Setup photos

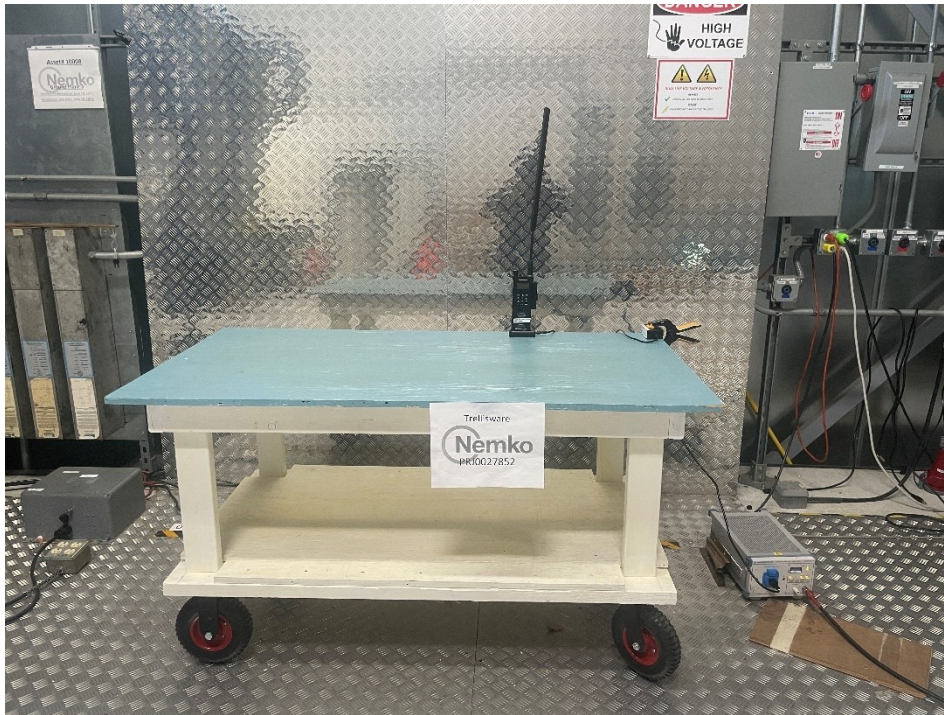

Figure 8.2.2 Conducted disturbance at AC mains port setup photo front

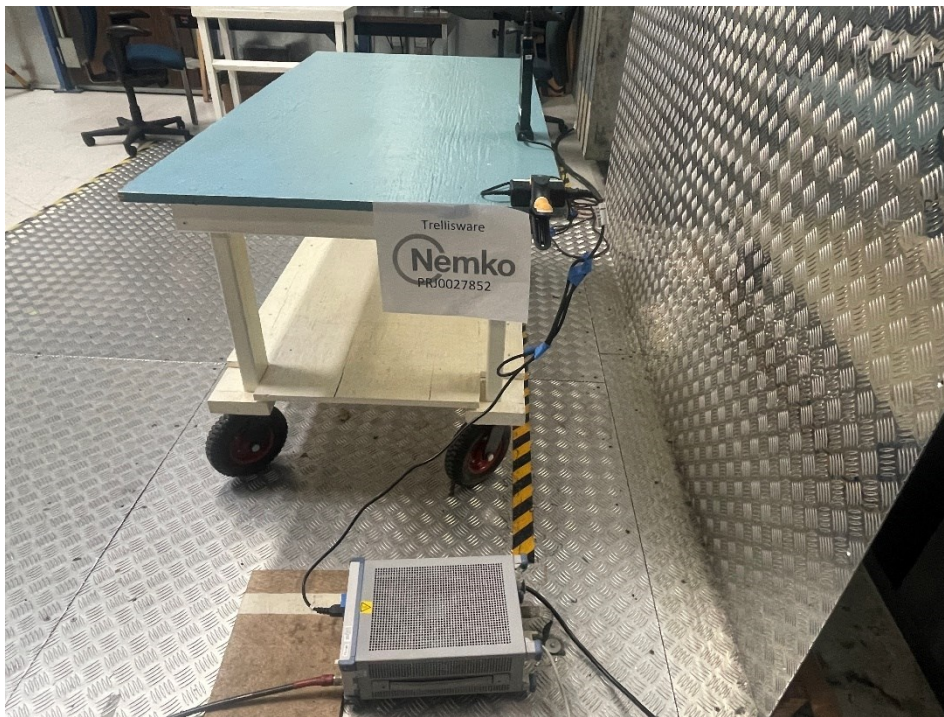

Figure 8.2.3 Conducted disturbance at AC mains port setup photo side

Section 9 Block diagrams of test set-ups

9.1 Radiated emissions set-up

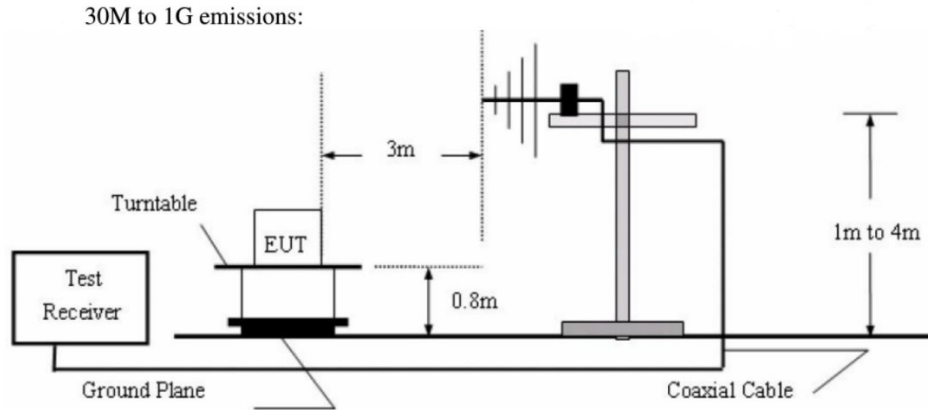

Figure 9.1.1 Radiated emissions, 30 to 1000 MHz setup

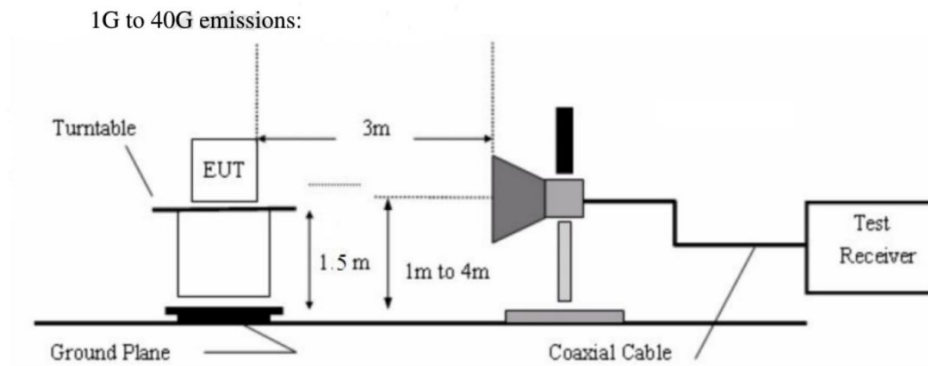

Figure 9.1.2 Radiated emissions, 1 to 40 GHz setup

9.2 Conducted emissions set-up

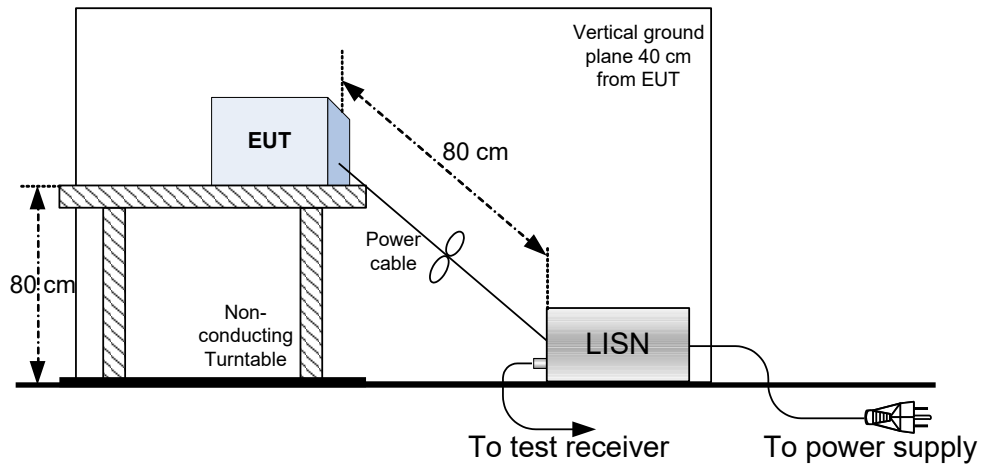

Figure 9.2.1 Conducted emissions, 150 kHz-30 MHz, setup