

Acknowledgment Letter

SPECIFICATION FOR APPROVAL

CUSTOMER`S NAME : Shenzhen Xinnengda Technology Co., Ltd

CUSTOMER`S P/N : _____

PRODUCT SPEC : Y. WAC. 062

ISSUE DATE : 2023/11/13

PREPARED BY	CHECKED BY	APPROVED BY	CUSTOMER APPROVE
Li Bei	Cheng Jie	Li Bowen	





DONGGUAN BOHONG TECHNOLOGY CO., LTD

ADD: 4th Floor, No. 533 Fumin Middle Road, Dalang Town, Dongguan City

TEL: 0769-82866410

FAX: 0769-82866409

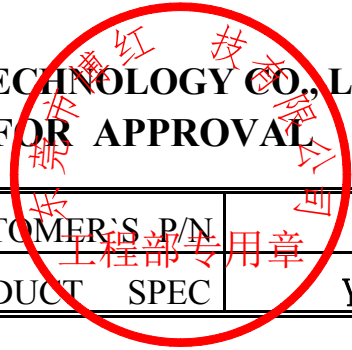
DONGGUAN BOHONG TECHNOLOGY CO., LTD
SPECIFICATION FOR APPROVAL



CUSTOMER	Xinnengda	CUSTOMER'S P/N	0
ISSUE DATE	2023/11/13	PRODUCT SPEC	Y. WAC. 062

2.DIMENSION:

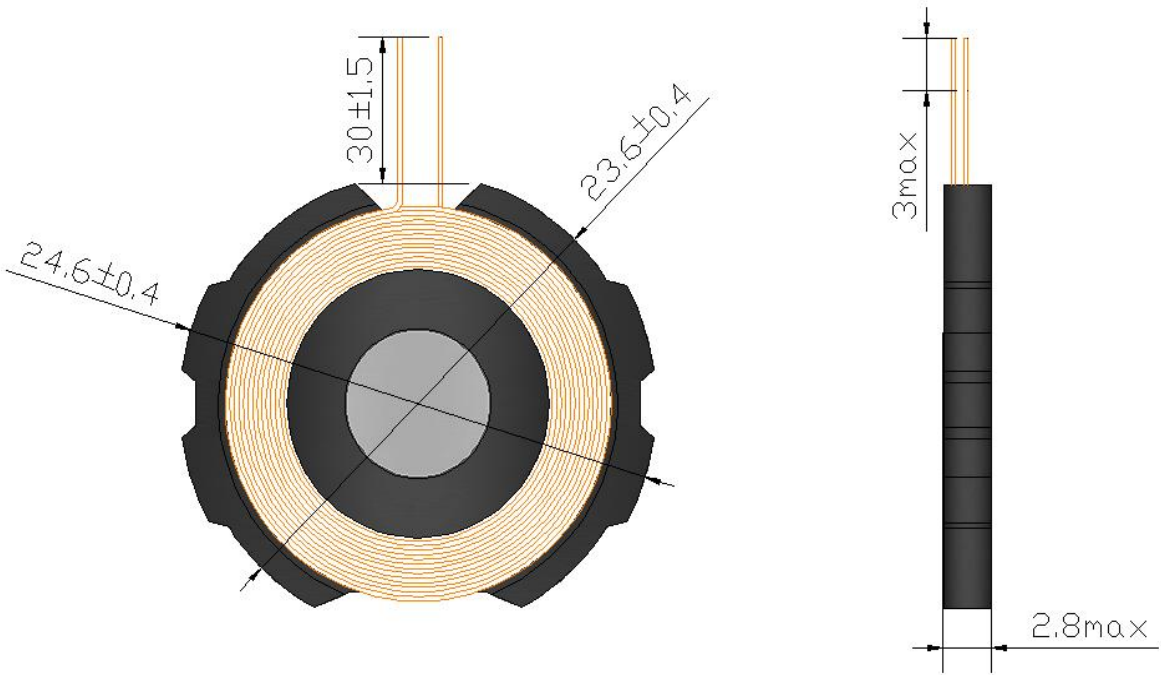

注: Back \varnothing 19 * T0.13 Crown 513 #
 double-sided tape; Magnet 7.5 *
 2.2mm Gaussian 2900-3100;

ISSUE BY	Li Bei	CHECK BY	Cheng Jie	APPROVAL BY	Li Bowen
----------	--------	----------	-----------	-------------	----------

DONGGUAN BOHONG TECHNOLOGY CO., LTD
SPECIFICATION FOR APPROVAL

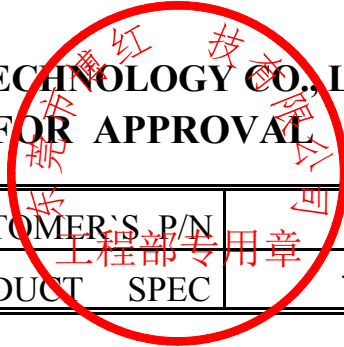

CUSTOMER	Xinnengda	CUSTOMER'S P/N	0
ISSUE DATE	2023/11/13	PRODUCT SPEC	Y. WAC. 062

4. CIRCUIT DIAGRAM

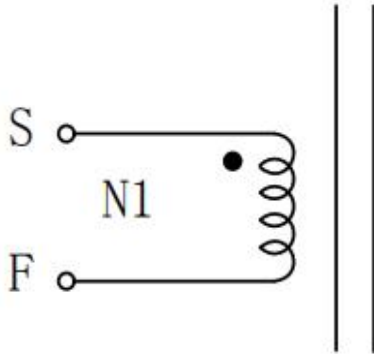

" ● " : POLARITY/极性

5. WINDING

NO	WINDING	WIRE	TURNS	TAPE	WINDING CONDITION
N1	S-F	Ø0.08*24P	14	/	CCW

Back Ø Back Ø 19 * T0.13 Crown 513 # double-sided
 tape; Magnet 7.5 * 2.2mm Gaussian 19 * T0.13 Crown
 513 # double-sided tape; Magnet 7.5 * 2.2mm
 Gaussian 2900-3100;

6. CHARACTERISTIC

ITEM	MEASURED POINT	TECHNICAL DATA	TESTING CONDITION & INSTRUMENT
LS	S-F	8.1uH±3%	LCR1062 100KHz/1V AT 25°C±2°C

DONGGUAN BOHONG TECHNOLOGY CO., LTD
SPECIFICATION FOR APPROVAL

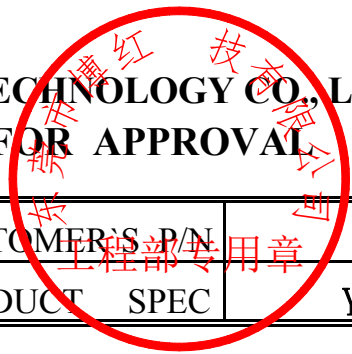

CUSTOMER	Xinnengda	CUSTOMER'S P/N	0
ISSUE DATE	2023/11/13	PRODUCT SPEC	Y. WAC. 062

7.THE PACKING WAY

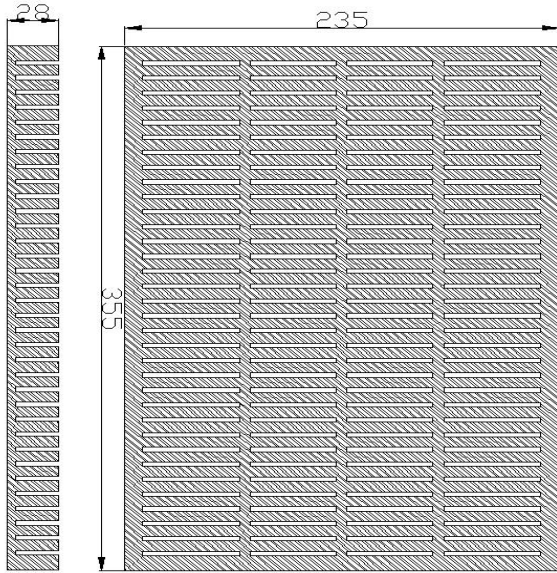

1. Pearl cotton specification: 375 * 265 * 30mm * 120 grids;
2. Pack 2 pieces per grid and 240 pieces per plate;
3. Pack 10 trays per box;
4. Total per box: 2400pcs;
5. Carton material: K=K++;

侧面图

俯视图

