

FCC TEST REPORT

FCC ID: 2A6T2-X98S500

Report Number : ZKT-220915L6883-03

Date of Test..... : Sep. 02, 2022 -- Sep. 21, 2022

Date of issue..... : Sep. 21, 2022

Total number of pages : 68

Test Result..... : PASS

Testing Laboratory : **Shenzhen ZKT Technology Co., Ltd.**

Address : 1/F, No. 101, Building B, No. 6, Tangwei Community Industrial Avenue, Fuhai Street, Bao'an District, Shenzhen, China

Applicant's name : SHENZHEN AMEDIA TECHNOLOGY CO., LTD

Address : Room 201, Building 2, Stech Park, Gaofeng community, Dalang Street, Longhua District, Shenzhen, China

Manufacturer's name : SHENZHEN AMEDIA TECHNOLOGY CO., LTD

Address : Room 201, Building 2, Stech Park, Gaofeng community, Dalang Street, Longhua District, Shenzhen, China

Test specification:

Standard : FCC CFR Title 47 Part 15 Subpart E Section 15.407
ANSI C63.10:2013
KDB 789033 D02 V01r02

Test procedure..... : /

Non-standard test method : N/A

Test Report Form No. : TRF-EL-110_V0

Test Report Form(s) Originator : ZKT Testing

Master TRF : Dated: 2020-01-06

This device described above has been tested by ZKT, and the test results show that the equipment under test (EUT) is in compliance with the FCC requirements. And it is applicable only to the tested sample identified in the report.

This report shall not be reproduced except in full, without the written approval of ZKT, this document may be altered or revised by ZKT, personal only, and shall be noted in the revision of the document.

Product name..... : TV Stick

Trademark : /

Model/Type reference : X98S500

Ratings : DC 5V from USB port or adapter

Testing procedure and testing location:

Testing Laboratory: **Shenzhen ZKT Technology Co., Ltd.**

Address: 1/F, No. 101, Building B, No. 6, Tangwei Community
Industrial Avenue, Fuhai Street, Bao'an District,
Shenzhen, China

Tested by (name + signature): Alen He

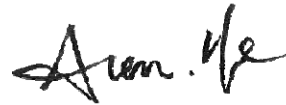

Reviewer (name + signature).....: Joe Liu



Approved (name + signature): Lake Xie



Table of Contents

	Page
1. VERSION	5
2. SUMMARY OF TEST RESULTS	6
2.1 TEST FACILITY	7
2.2 MEASUREMENT UNCERTAINTY	7
3. GENERAL INFORMATION	8
3.1 GENERAL DESCRIPTION OF EUT	8
3.2 DESCRIPTION OF TEST MODES	9
3.3 BLOCK DIGRAM SHOWING THE CONFIGURATION OF SYSTEM TESTED	9
3.4 DESCRIPTION OF SUPPORT UNITS(CONDUCTED MODE)	9
3.5EQUIPMENTS LIST FOR ALL TEST ITEMS	10
4. EMC EMISSION TEST	11
4.1 CONDUCTED EMISSION MEASUREMENT	11
4.1.1 POWER LINE CONDUCTED EMISSION LIMITS	11
4.1.2 TEST PROCEDURE	11
4.1.3 DEVIATION FROM TEST STANDARD	11
4.1.4 TEST SETUP	12
4.1.5 EUT OPERATING CONDITIONS	12
4.1.6 TEST RESULT	13
4.2 RADIATED EMISSION MEASUREMENT	15
4.2.1 RADIATED EMISSION LIMITS	15
4.2.2 TEST PROCEDURE	16
4.2.3 DEVIATION FROM TEST STANDARD	16
4.2.4 TEST SETUP	17
4.2.5 EUT OPERATING CONDITIONS	17
4.2.6 TEST RESULTS	18
5.POWER SPECTRAL DENSITY TEST	36
5.1 APPLIED PROCEDURES / LIMIT	36
5.2 TEST PROCEDURE	36
5.3 DEVIATION FROM STANDARD	36
5.4 TEST SETUP	36
5.5 EUT OPERATION CONDITIONS	37
5.6 TEST RESULT	37
6. -26 DB & 6DBM EMISSION BANDWIDTH	44
6.1 APPLIED PROCEDURES / LIMIT	44
6.2 TEST PROCEDURE	44
6.3 DEVIATION FROM STANDARD	44
6.4 TEST SETUP	44
6.5 EUT OPERATION CONDITIONS	44

6.6 TEST RESULT	44
7. OUTPUT POWER TEST	52
7.1 APPLIED PROCEDURES/LIMIT	52
7.2 DEVIATION FROM STANDARD	52
7.3 TEST SETUP	52
7.4 EUT OPERATION CONDITIONS	52
7.5 TEST RESULT	53
8. OUT OF BAND EDGE EMISSION	54
8.1 TEST PROCEDURE	54
8.2 DEVIATION FROM STANDARD	54
8.3 TEST SETUP	54
8.4 EUT OPERATION CONDITIONS	54
8.5 TEST RESULTS	54
9. FREQUENCY STABILITY MEASUREMENT	59
9.4 TEST RESULT	59
10. ANTENNA REQUIREMENT	67
11. TEST SETUP PHOTO	68
12. EUT CONSTRUCTIONAL DETAILS	68

1. VERSION

Report No.	Version	Description	Approved
ZKT-220915L6883-03	Rev.01	Initial issue of report	Sep. 21, 2022

2. SUMMARY OF TEST RESULTS

Test procedures according to the technical standards:

FCC Part15 (15.247) , Subpart C			
Standard Section	Test Item	Result	Remark
15.203/15.247 (c)	Antenna requirement	PASS	
15.207	AC Power Line Conducted Emission	PASS	
15.407 (a) (b)	Spurious Radiated Emissions and Band Edge	PASS	
15.407 (e) /15.403(i)	6 dB bandwidth, 26dB Emission Bandwidth& 99% Occupied Bandwidth	PASS	
15.407 (a)	Power Spectral Density	PASS	
15.407 (a)(1)(2)(3)	Maximum conducted output power	PASS	
15.407 (g)	Frequency Stability	PASS	

NOTE:

(1)" N/A" denotes test is not applicable in this Test Report

2.1 TEST FACILITY

Shenzhen ZKT Technology Co., Ltd.

Add. : 1/F, No. 101, Building B, No. 6, Tangwei Community Industrial Avenue, Fuhai Street, Bao'an District, Shenzhen, China

FCC Test Firm Registration Number: 692225

Designation Number: CN1299

IC Registered No.: 27033

2.2 MEASUREMENT UNCERTAINTY

The reported uncertainty of measurement $y \pm U$, where expanded uncertainty U is based on a standard uncertainty multiplied by a coverage factor of $k=2$, providing a level of confidence of approximately 95 %.

No.	tem	ncertainty
1	3m chamber Radiated spurious emission(30MHz-1GHz)	U=4.3dB
2	3m chamber Radiated spurious emission(1GHz-18GHz)	U=4.5dB
3	3m chamber Radiated spurious emission(18GHz-40GHz)	U=3.34dB
4	Conducted Adjacent channel power	U=1.38dB
5	Conducted output power uncertainty Above 1G	U=1.576dB
6	Conducted output power uncertainty below 1G	U=1.28dB
7	humidity uncertainty	U=5.3%
8	Temperature uncertainty	U=0.59°C
9	Radiated disturbance(30MHz-1000MHz)	U=4.8dB
10	Radiated disturbance(1GHz-6GHz)	U=4.9dB
11	Radiated disturbance(1GHz-18GHz)	U=5.0dB

3. GENERAL INFORMATION

3.1 GENERAL DESCRIPTION OF EUT

Product Name:	TV Stick			
Model No.:	X98S500			
Serial No.:	/			
Hardware Version:	DM916_428_V1.1			
Software Version:	SecureCRT			
Sample(s) Status:	Engineer sample			
	IEEE802.11 WLAN mode supported	802.11a/n/ac(20MHz channel bandwidth) 802.11n/ac(40MHz channel bandwidth) 802.11 ac (80MHz channel bandwidth)		
	Date rate	802.11ac:MCS0-MCS9 802.11n: MCS0-MCS7 802.11a: 6.5-54Mbps		
	Modulation	OFDM/OFDMA		
	U-NII-1	Frequency Range	802.11a/n/ac(20MHz) : 5180-5240MHz 802.11n/ac(40MHz) : 5190-5230MHz 802.11 ac (80MHz) : 5210MHz	
		Channels	802.11 a/n/ac (20MHz): 4 802.11 ac /n (40MHz): 2 802.11 ac (80MHz): 1	
	U-NII-3	Frequency Range	802.11 a/n/ac(20MHz) : 5745-5825 MHz 802.11 n/ac (40MHz): 5755-5795 MHz 802.11 ac (80MHz): 5775 MHz	
Channels		802.11 a/n/ac(20MHz) : 5 802.11 n/ac (40MHz): 2 802.11 ac (80MHz): 1		
Antenna Type:	FPC antenna			
Antenna gain:	1.09dBi			
POWER ADAPTER:	DC 5V from USB port or adapter			

U-NII-1		U-NII-3	
CH.	Frequency (MHz)	CH.	Frequency (MHz)
36	5180	149	5745
40	5200
44	5220	157	5785
48	5240
		165	5825

802.11a/n/ac(20MHz) Frequency / Channel Operations

U-NII-1		U-NII-3	
CH.	Frequency (MHz)	CH.	Frequency (MHz)
38	5190	151	5755
46	5230	159	5795

802.11n /ac(40MHz BW) Frequency / Channel Operations

U-NII-1	U-NII-3
---------	---------

CH.	Frequency (MHz)	CH.	Frequency (MHz)
42	5210	155	5775

802.11ac (80MHz BW) Frequency / Channel Operations

3.2 DESCRIPTION OF TEST MODES

Worst Case Configuration: transmitting both 2.4GHz mode and 5GHz mode

Description	5 GHz Emission
Antenna	ANT1
Channel	149
Operating Frequency (MHz)	802.11ac
Data Rate (Mbps)	OFDM/MCS11
Mode	U-NII-3 -5745MHz

3.3 BLOCK DIGRAM SHOWING THE CONFIGURATION OF SYSTEM TESTED

Conducted Emission

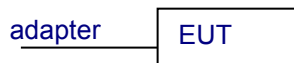

Radiated Emission

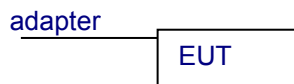

Conducted Spurious

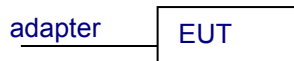

3.4 DESCRIPTION OF SUPPORT UNITS(CONDUCTED MODE)

The EUT has been tested as an independent unit together with other necessary accessories or support units. The following support units or accessories were used to form a representative test configuration during the tests.

Item	Equipment	Mfr/Brand	Model/Type No.	Series No.	Note
1	adapter	HUAWEI	HW-100100C01	/	SDOC
2	PC	HP	HP40	/	SDOC

Item	Shielded Type	Ferrite Core	Length	Note

Note:

- (1) The support equipment was authorized by Declaration of Confirmation.
- (2) For detachable type I/O cable should be specified the length in cm in 『Length』 column.

3.5EQUIPMENTS LIST FOR ALL TEST ITEMS

Radiation Test equipment

Item	Equipment	Manufacturer	Type No.	Serial No.	Last calibration	Calibrated until
1	Spectrum Analyzer (9kHz-26.5GHz)	KEYSIGHT	9020A	MY55370835	Oct. 18, 2021	Oct. 17, 2022
2	Spectrum Analyzer (1GHz-40GHz)	R&S	FSQ	100363	Oct. 17, 2021	Oct. 16, 2022
3	EMI Test Receiver (9kHz-7GHz)	R&S	ESCI7	101169	Oct. 18, 2021	Oct. 17, 2022
4	Bilog Antenna (30MHz-1500MHz)	Schwarzbeck	VULB9168	N/A	Oct. 17, 2021	Oct. 16, 2022
5	Horn Antenna (1GHz-18GHz)	Agilent	AH-118	071145	Oct. 17, 2021	Oct. 16, 2022
6	Loop Antenna	TESEQ	HLA6121	58357	Oct. 17, 2021	Oct. 16, 2022
7	Amplifier (30-1000MHz)	EM Electronics	EM330 Amplifier	060747	Oct. 17, 2021	Oct. 16, 2022
8	Amplifier (1GHz-26.5GHz)	Agilent	8449B	3008A00315	Oct. 18, 2021	Oct. 17, 2022
9	RF cables1 (9kHz-30MHz)	N/A	9kHz-30MHz	N/A	Oct. 18, 2021	Oct. 17, 2022
10	RF cables2 (30MHz-1GHz)	N/A	30MHz-1GHz	N/A	Oct. 18, 2021	Oct. 17, 2022
11	RF cables3 (1GHz-40GHz)	N/A	1GHz-40GHz	N/A	Oct. 18, 2021	Oct. 17, 2022
12	ESG Signal Generator	Agilent	E4421B	N/A	Oct. 18, 2021	Oct. 17, 2022
13	Signal Generator	Agilent	N5182A	N/A	Oct. 22, 2021	Oct. 21, 2022
14	Magnetic Field Probe Tester	Narda	ELT-400	0-0344	Oct. 17, 2021	Oct. 16, 2022
15	MWRF Power Meter Test system	MW	MW100-RPC B	N/A	Oct. 22, 2021	Oct. 21, 2022
16	D.C. Power Supply	LongWei	TPR-6405D	N/A	\	\
17	EMC Software	Frad	EZ-EMC	Ver.EMC-CON 3A1.1	\	\
18	RF Software	MW	MTS8310	V2.0.0.0	\	\
19	Turntable	MF	MF-7802BS	N/A	\	\
20	Antenna tower	MF	MF-7802BS	N/A	\	\

Conduction Test equipment

Item	Kind of Equipment	Manufacturer	Type No.	Serial No.	Last calibration	Calibrated until
1	LISN	R&S	ENV216	101471	Oct. 22, 2021	Oct. 21, 2022
2	LISN	CYBERTEK	EM5040A	E1850400149	Oct. 22, 2021	Oct. 21, 2022
3	Test Cable	N/A	C01	N/A	Oct. 18, 2021	Oct. 17, 2022
4	Test Cable	N/A	C02	N/A	Oct. 18, 2021	Oct. 17, 2022
5	EMI Test Receiver	R&S	ESCI3	101393	Oct. 17, 2021	Oct. 16, 2022
6	EMC Software	Frad	EZ-EMC	Ver.EMC-CO N 3A1.1	\	\

4. EMC EMISSION TEST

4.1 CONDUCTED EMISSION MEASUREMENT

Test Requirement:	FCC Part15 C Section 15.207
Test Method:	ANSI C63.10:2013
Test Frequency Range:	150KHz to 30MHz
Receiver setup:	RBW=9KHz, VBW=30KHz, Sweep time=auto

4.1.1 POWER LINE CONDUCTED EMISSION LIMITS

FREQUENCY (MHz)	Limit (dBuV)		Standard
	Quasi-peak	Average	
0.15 -0.5	66 - 56 *	56 - 46 *	FCC
0.50 -5.0	56.00	46.00	FCC
5.0 -30.0	60.00	50.00	FCC

Note:

(1) *Decreases with the logarithm of the frequency.

4.1.2 TEST PROCEDURE

1. The equipment was set up as per the test configuration to simulate typical actual usage per the user's manual. The EUT is a tabletop system; a wooden table with a height of 0.8 meters is used and is placed on the ground plane as per ANSI C63.10:2013.
2. Support equipment, if needed, was placed as per ANSI C63.10:2013
3. All I/O cables were positioned to simulate typical actual usage as per ANSI C63.10:2013.
4. The adapter received AC120V/60Hz power through a Line Impedance Stabilization Network (LISN) which supplied power source and was grounded to the ground plane.
5. All support equipments received AC power from a second LISN, if any.
6. The EUT test program was started. Emissions were measured on each current carrying line of the EUT using a spectrum Analyzer / Receiver connected to the LISN powering the EUT. The LISN has two monitoring points: Line 1 (Hot Side) and Line 2 (Neutral Side). Two scans were taken: one with Line 1 connected to Analyzer / Receiver and Line 2 connected to a 50 ohm load; the second scan had Line 1 connected to a 50 ohm load and Line 2 connected to the Analyzer / Receiver.
7. Analyzer / Receiver scanned from 150 KHz to 30MHz for emissions in each of the test modes.e.
8. For the actual test configuration, please refer to the related Item –EUT Test Photos.

4.1.3 DEVIATION FROM TEST STANDARD

No deviation

4.1.4 TEST SETUP

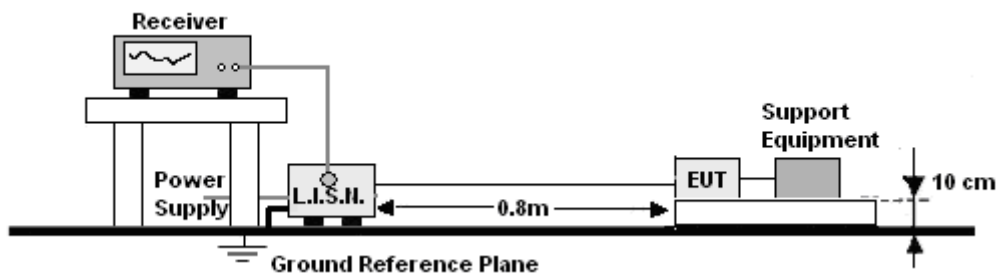

4.1.5 EUT OPERATING CONDITIONS

The EUT was configured for testing in a typical fashion (as a customer would normally use it). The EUT has been programmed to continuously transmit during test. This operating condition was tested and used to collect the included data.

We pretest AC 120V , the worst voltage was AC 120V and the data recording in the report.

4.1.6 TEST RESULT

Temperature :	26°C	Relative Humidity:	54%
Pressure :	101kPa	Phase :	L
Test Voltage :	AC 120V/60Hz		

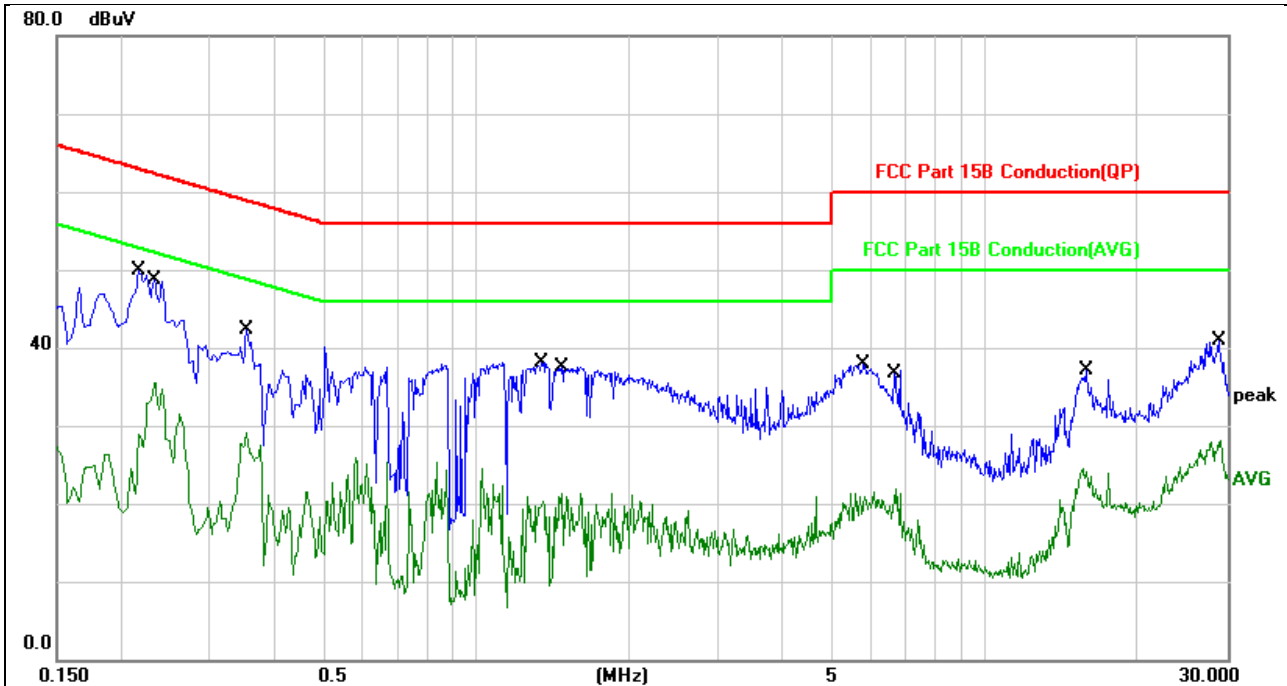

No.	Mk.	Freq. MHz	Reading Level dBuV	Correct Factor dB	Measure- ment dBuV	Limit dBuV	Over dB	Detector	Comment
1	*	0.2180	40.15	9.76	49.91	62.89	-12.98	QP	
2		0.2340	25.74	9.76	35.50	52.30	-16.80	AVG	
3		0.3540	32.37	9.86	42.23	58.87	-16.64	QP	
4		0.3540	19.15	9.86	29.01	48.87	-19.86	AVG	
5		1.3500	28.39	9.71	38.10	56.00	-17.90	QP	
6		1.4780	11.81	9.89	21.30	46.00	-24.70	AVG	
7		5.7900	28.33	9.65	37.98	60.00	-22.02	QP	
8		6.8900	12.22	9.62	21.84	50.00	-28.16	AVG	
9		15.8140	14.78	9.64	24.40	50.00	-25.60	AVG	
10		15.8500	27.48	9.64	37.12	60.00	-22.88	QP	
11		28.8540	31.48	9.51	40.99	60.00	-19.01	QP	
12		29.0820	18.57	9.50	28.07	50.00	-21.93	AVG	

Notes:

1. An initial pre-scan was performed on the line and neutral lines with peak detector.
2. Quasi-Peak and Average measurement were performed at the frequencies with maximized peak emission.
3. Measurement Level = Reading level + Correct Factor

Temperature :	26°C	Relative Humidity:	54%
Pressure :	101kPa	Phase :	N
Test Voltage :	AC 120V/60Hz		

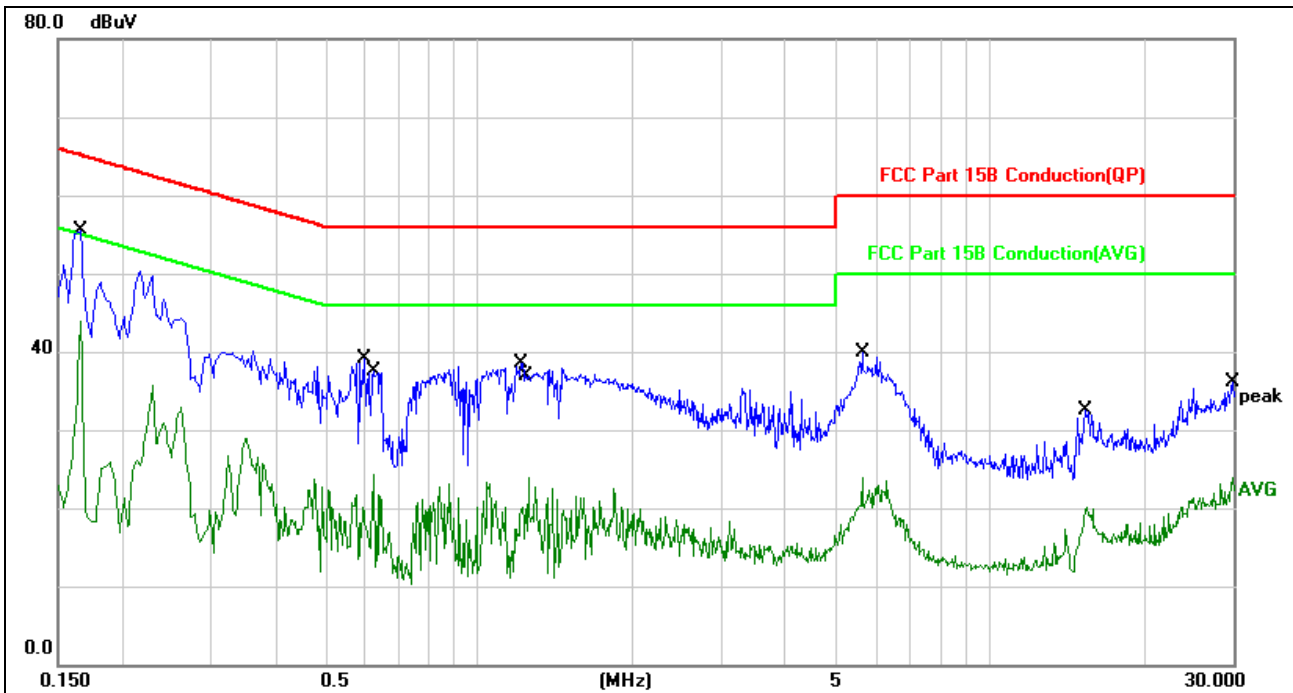

No.	Mk.	Freq.	Reading Level	Correct Factor	Measurement	Limit	Over	Detector	Comment
		MHz	dBuV	dB	dBuV	dBuV	dB		
1	*	0.1660	45.71	9.75	55.46	65.15	-9.69	QP	
2		0.1660	34.13	9.75	43.88	55.15	-11.27	AVG	
3		0.5980	29.30	9.84	39.14	56.00	-16.86	QP	
4		0.6260	14.57	9.83	24.40	46.00	-21.60	AVG	
5		1.2100	28.83	9.73	38.56	56.00	-17.44	QP	
6		1.2540	14.10	9.72	23.82	46.00	-22.18	AVG	
7		5.6460	30.30	9.65	39.95	60.00	-20.05	QP	
8		5.6460	14.28	9.65	23.93	50.00	-26.07	AVG	
9		15.4500	22.82	9.65	32.47	60.00	-27.53	QP	
10		15.5260	10.55	9.65	20.20	50.00	-29.80	AVG	
11		29.9700	26.60	9.49	36.09	60.00	-23.91	QP	
12		29.9700	14.44	9.49	23.93	50.00	-26.07	AVG	

Notes:

1. An initial pre-scan was performed on the line and neutral lines with peak detector.
2. Quasi-Peak and Average measurement were performed at the frequencies with maximized peak emission.
3. Measurement Level = Reading level + Correct Factor

4.2 RADIATED EMISSION MEASUREMENT

4.2.1 RADIATED EMISSION LIMITS

1. Radiated emissions from 9 kHz to 25 GHz were measured according to the methods defines in ANSI C63.10-2013. The EUT was placed above the ground plane, 0.8 meter for frequency below 1GHz and 1.5 meter for frequency above 1GHz. The interface cable and equipment positions were varied within limits of reasonable applications to determine the positions producing maximum radiated emissions.
2. For transmitters operating in the 5150-5250 MHz band: all emissions outside of the 5150-5350 MHz band shall not exceed an EIRP of -27dBm/MHz .
3. For transmitters operating in the 5250-5350 MHz band: all emissions outside of the 5150-5350 MHz band shall not exceed an EIRP of -27 dBm/MHz . Devices operating in the 5250-5350 MHz band that generate emissions in the 5150-5250 MHz band must meet all applicable technical requirements for operation in the 5150-5250 MHz band (including indoor use) or alternatively meet an out-of-band emission EIRP limit of -27 dBm/MHz in the 5150-5250 MHz band.
4. For transmitters operating in the 5470-5600 MHz and 5650-5725MHz band: all emissions outside of the 5470-5600 MHz and 5650-5725MHz band shall not exceed an EIRP of -27 dBm/MHz .
5. KDB789033v02r01G)2)c) As specified in 15.407(b), emissions above 1000MHz that are out side of the restricted bands are subject to a peak emission limit of -27 dBm/MHz (or -17 dBm/MHz as specified in 15.407(b)(4)). However, an out-of-band emission that complies with both the average and peak limits of 15.209 is not required to satisfy the -27 dBm/MHz or -17 dBm/MHz peak emission limit.

According to §15.209(a), except as provided elsewhere in this Subpart, the emissions from an intentional radiator shall not exceed the field strength levels specified in the following table:

Frequencies (MHz)	Field Strength (micovolts/meter)	Measurement Distance (meters)
0.009~0.490	2400/F(KHz)	300
0.490~1.705	24000/F(KHz)	30
1.705~30.0	30	30
30~88	100	3
88~216	150	3
216~960	200	3
Above 960	500	3

LIMITS OF RADIATED EMISSION MEASUREMENT

FREQUENCY (MHz)	Limit (dBuV/m) (at 3M)	
	PEAK	AVERAGE
Above 1000	74	54

Notes:

- (1) The limit for radiated test was performed according to FCC PART 15C.
- (2) The tighter limit applies at the band edges.
- (3) Emission level (dBuV/m)=20log Emission level (uV/m).

4.2.2 TEST PROCEDURE

Below 1GHz test procedure as below:

- a. The EUT was placed on the top of a rotating table 0.1 meters above the ground at a 3 meter semi-anechoic chamber. The table was rotated 360 degrees to determine the position of the highest radiation.
- b. The EUT was set 3 meters away from the interference-receiving antenna, which was mounted on the top of a variable-height antenna tower.
- c. The antenna height is varied from one meter to four meters above the ground to determine the maximum value of the field strength. Both horizontal and vertical polarizations of the antenna are set to make the measurement.
- d. For each suspected emission, the EUT was arranged to its worst case and then the antenna was tuned to heights from 1 meter to 4 meters (for the test frequency of below 30MHz, the antenna was tuned to heights 1 meter) and the rotatable table was turned from 0 degrees to 360 degrees to find the maximum reading.
- e. The test-receiver system was set to Peak Detect Function and Specified Bandwidth with Maximum Hold Mode.
- f. If the emission level of the EUT in peak mode was 10dB lower than the limit specified, then testing could be stopped and the peak values of the EUT would be reported. Otherwise the emissions that did not have 10dB margin would be re-tested one by one using peak, quasi-peak or average method as specified and then reported in a data sheet.

Above 1GHz test procedure as below:

- g. Different from above is the test site, change from Semi- Anechoic Chamber to fully Anechoic Chamber and change from table 0.8 metre to 1.5 metre (Above 18GHz the distance is 1 meter and table is 1.5 metre).
- h. Test the EUT in the lowest channel, the middle channel, the Highest channel

Note:

Both horizontal and vertical antenna polarities were tested and performed pretest to three orthogonal axis. The worst case emissions were reported

4.2.3 DEVIATION FROM TEST STANDARD

No deviation

4.2.4 TEST SETUP

(A) Radiated Emission Test-Up Frequency Below 30MHz

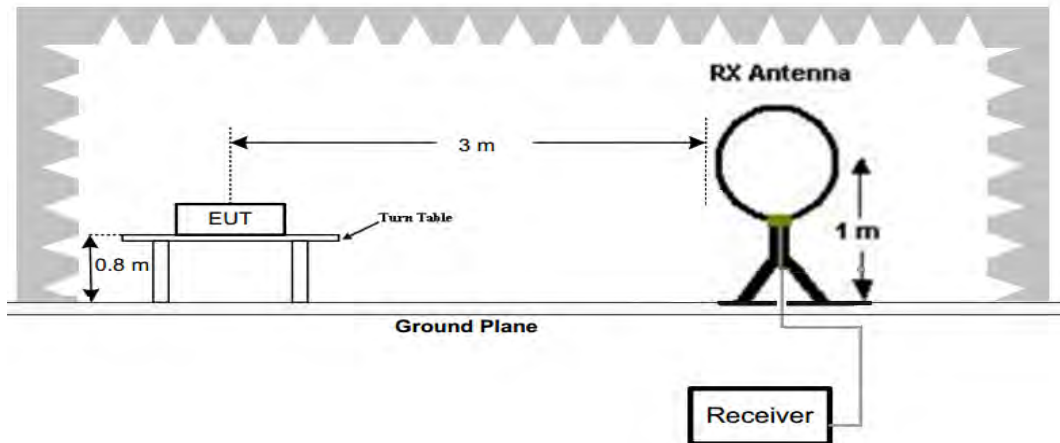

(B) Radiated Emission Test-Up Frequency 30MHz~1GHz

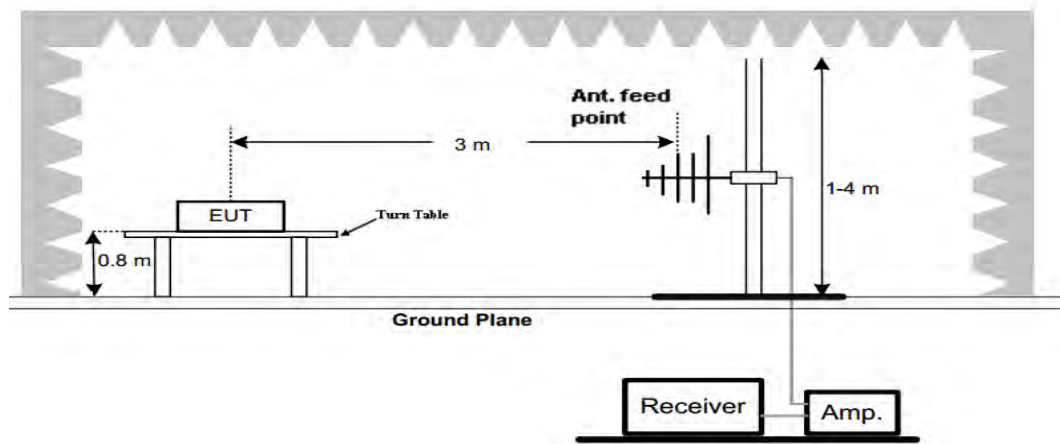

(C) Radiated Emission Test-Up Frequency Above 1GHz

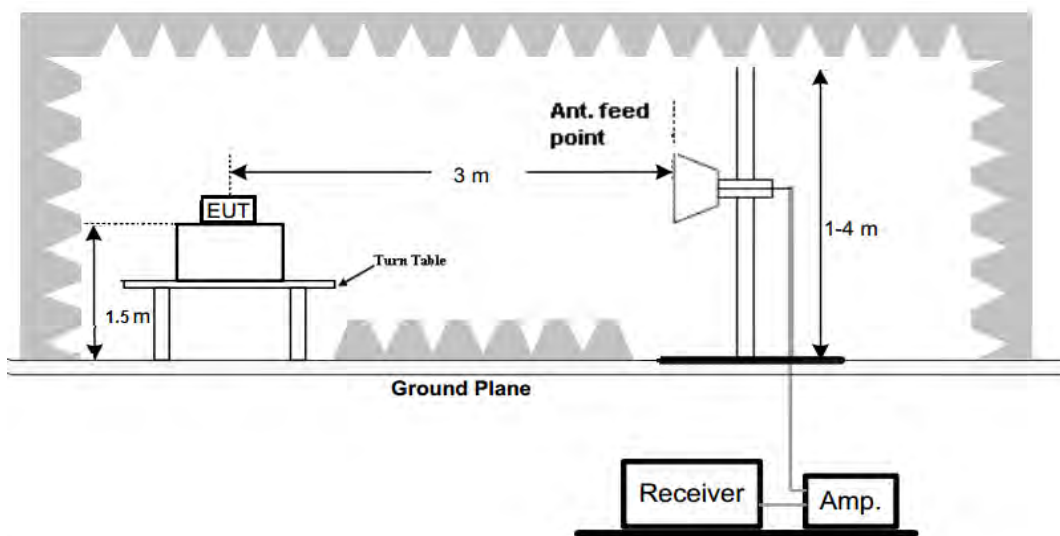

4.2.5 EUT OPERATING CONDITIONS

The EUT tested system was configured as the statements of 2.4 Unless otherwise a special operating condition is specified in the follows during the testing.

4.2.6 TEST RESULTS

Between 9KHz – 30MHz

The emission from 9 kHz to 30MHz was pre-tested and found the result was 20dB lower than the limit, and according to 15.31(o) & RSS-Gen 6.13, the test result no need to reported.

Between 30MHz – 1GHz

Temperature:	26°C	Relative Humidity:	54%
Pressure:	101 kPa	Polarization:	Horizontal
Test Voltage:	AC 120V/60Hz		

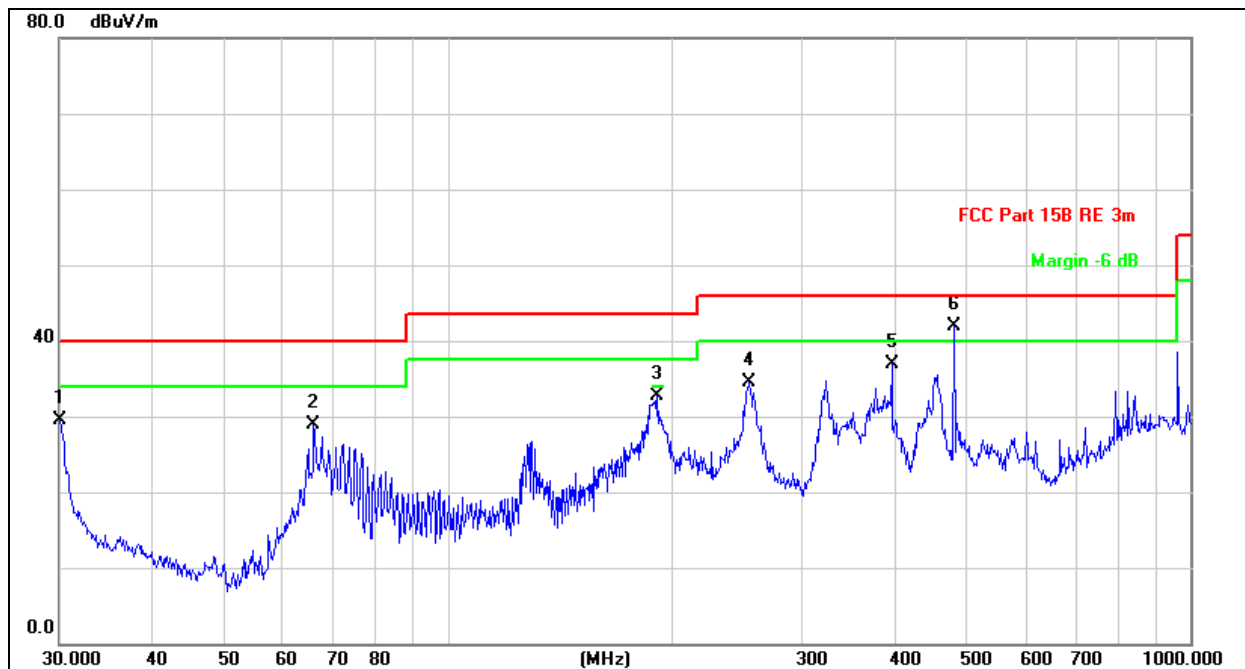

No.	Mk.	Freq.	Reading Level	Correct Factor	Measurement	Limit	Over	Antenna Height	Table Degree	
		MHz	dBuV	dB/m	dBuV/m	dBuV/m	dB	cm	degree	Comment
1		30.1054	28.05	1.43	29.48	40.00	-10.52	QP	100	360
2		66.0342	43.36	-14.46	28.90	40.00	-11.10	QP	100	360
3		191.7450	39.44	-6.68	32.76	40.00	-7.24	QP	100	360
4		254.7284	40.30	-5.85	34.45	47.00	-12.55	QP	100	360
5		396.2415	38.96	-2.07	36.89	47.00	-10.11	QP	100	360
6	*	480.5276	42.03	-0.06	41.97	47.00	-5.03	QP	100	360

Temperature:	26°C	Relative Humidity:	54%
Pressure:	101kPa	Polarization:	Vertical
Test Voltage:	AC 120V/60Hz		

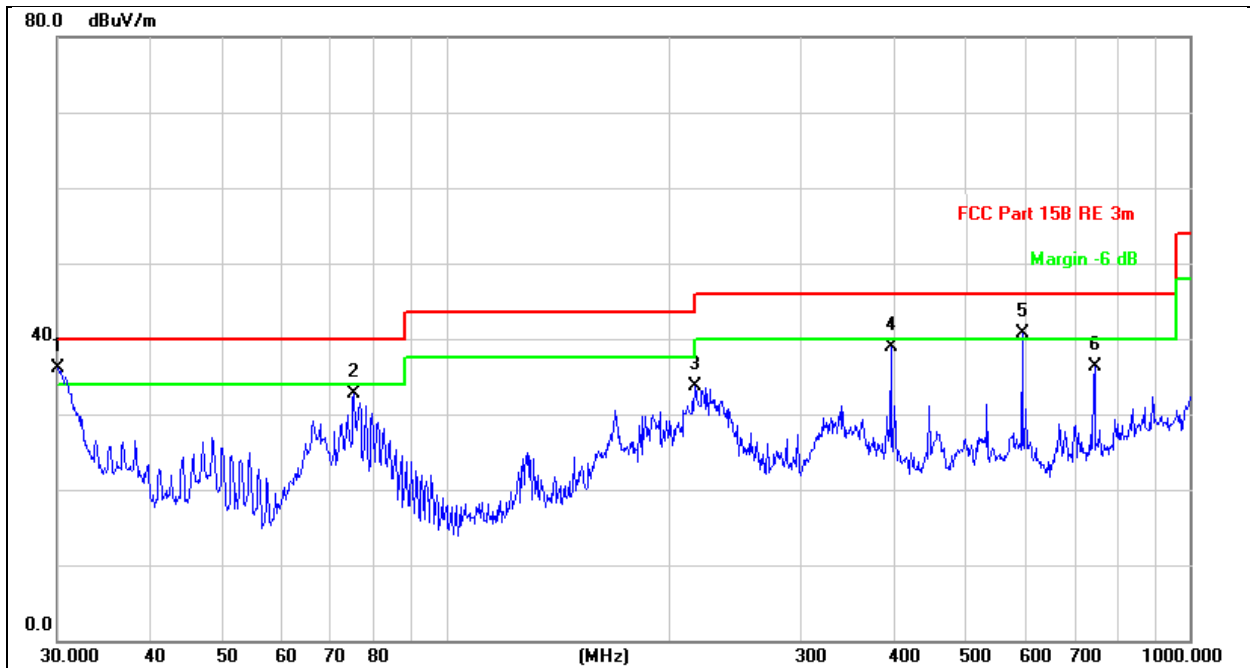

No.	Mk.	Freq.	Reading Level	Correct Factor	Measurement	Limit	Over	Antenna Height	Table Degree
		MHz	dBuV	dB/m	dBuV/m	dBuV/m	dB	cm	degree
1	*	30.1054	34.66	1.43	36.09	40.00	-3.91	QP 100	0
2		75.1822	46.29	-13.59	32.70	40.00	-7.30	QP 100	0
3		216.0240	40.89	-7.11	33.78	40.00	-6.22	QP 100	0
4		396.2415	40.91	-2.07	38.84	47.00	-8.16	QP 100	0
5		595.1329	39.52	1.12	40.64	47.00	-6.36	QP 100	0
6		744.8661	34.91	1.49	36.40	47.00	-10.60	QP 100	0

Remarks:

1. Final Level = Receiver Read level + Antenna Factor + Cable Loss – Preamplifier Factor
2. The emission levels of other frequencies are very lower than the limit and not show in test report.

802.11a

Polar (H/V)	Frequency	Meter Reading	Pre-ampl ifier	Cable Loss	Antenna Factor	Emission Level	Limits	Margin	Detect or Type
	(MHz)	(dBuV)	(dB)	(dB)	(dB)	(dBuV/m)	(dBuV/ m)	(dB)	
Low Channel:5180MHz									
V	10360	49.33	30.55	5.77	24.66	49.21	74.00	-24.79	PK
V	10360	34.82	30.55	5.77	24.66	34.70	54.00	-19.30	AV
V	15540	49.73	30.33	6.32	24.55	50.27	74.00	-23.73	PK
V	15540	40.29	30.33	6.32	24.55	40.83	54.00	-13.17	AV
V	20720	49.78	30.85	7.45	24.69	51.07	74.00	-22.93	PK
V	20720	39.16	30.85	7.45	24.69	40.45	54.00	-13.55	AV
H	10360	47.70	30.55	5.77	24.66	47.58	74.00	-26.42	PK
H	10360	38.87	30.55	5.77	24.66	38.75	54.00	-15.25	AV
H	15540	46.92	30.33	6.32	24.55	47.46	74.00	-26.54	PK
H	15540	40.40	30.33	6.32	24.55	40.94	54.00	-13.06	AV
H	20720	49.77	30.85	7.45	24.69	51.06	74.00	-22.94	PK
H	20720	39.86	30.85	7.45	24.69	41.15	54.00	-12.85	AV

Polar (H/V)	Frequency	Meter Reading	Pre-ampl ifier	Cable Loss	Antenna Factor	Emission Level	Limits	Margin	Detect or Type
	(MHz)	(dBuV)	(dB)	(dB)	(dB)	(dBuV/m)	(dBuV/ m)	(dB)	
Middle Channel:5200MHz									
V	10400	47.22	30.55	5.77	24.66	47.10	74.00	-26.90	PK
V	10400	35.63	30.55	5.77	24.66	35.51	54.00	-18.49	AV
V	15600	47.76	30.33	6.32	24.55	48.30	74.00	-25.70	PK
V	15600	39.96	30.33	6.32	24.55	40.50	54.00	-13.50	AV
V	20800	51.60	30.85	7.45	24.69	52.89	74.00	-21.11	PK
V	20800	40.13	30.85	7.45	24.69	41.42	54.00	-12.58	AV
H	10400	47.15	30.55	5.77	24.66	47.03	74.00	-26.97	PK
H	10400	38.32	30.55	5.77	24.66	38.20	54.00	-15.80	AV
H	15600	46.91	30.33	6.32	24.55	47.45	74.00	-26.55	PK
H	15600	39.72	30.33	6.32	24.55	40.26	54.00	-13.74	AV
H	20800	49.61	30.85	7.45	24.69	50.90	74.00	-23.10	PK
H	20800	38.77	30.85	7.45	24.69	40.06	54.00	-13.94	AV

Polar (H/V)	Frequency	Meter Reading	Pre-ampli fier	Cable Loss	Antenna Factor	Emission Level	Limits	Margin	Detect or Type
	(MHz)	(dBuV)	(dB)	(dB)	(dB)	(dBuV/m)	(dBuV/ m)	(dB)	
High Channel:5240MHz									
V	10480	48.10	30.55	5.77	24.66	47.98	74.00	-26.02	PK
V	10480	36.59	30.55	5.77	24.66	36.47	54.00	-17.53	AV
V	15720	48.42	30.33	6.32	24.55	48.96	74.00	-25.04	PK
V	15720	40.78	30.33	6.32	24.55	41.32	54.00	-12.68	AV
V	20960	50.94	30.85	7.45	24.69	52.23	74.00	-21.77	PK
V	20960	39.35	30.85	7.45	24.69	40.64	54.00	-13.36	AV
H	10480	47.17	30.55	5.77	24.66	47.05	74.00	-26.95	PK
H	10480	39.22	30.55	5.77	24.66	39.10	54.00	-14.90	AV
H	15720	48.41	30.33	6.32	24.55	48.95	74.00	-25.05	PK
H	15720	39.72	30.33	6.32	24.55	40.26	54.00	-13.74	AV
H	20960	51.07	30.85	7.45	24.69	52.36	74.00	-21.64	PK
H	20960	41.54	30.85	7.45	24.69	42.83	54.00	-11.17	AV

Polar (H/V)	Frequency	Meter Reading	Pre-ampli fier	Cable Loss	Antenna Factor	Emission Level	Limits	Margin	Detect or Type
	(MHz)	(dBuV)	(dB)	(dB)	(dB)	(dBuV/m)	(dBuV/ m)	(dB)	
High Channel:5745MHz									
V	11490	47.42	30.55	5.77	24.66	47.30	74.00	-26.70	PK
V	11490	35.24	30.55	5.77	24.66	35.12	54.00	-18.88	AV
V	17235	48.51	30.33	6.32	24.55	49.05	74.00	-24.95	PK
V	17235	41.63	30.33	6.32	24.55	42.17	54.00	-11.83	AV
V	22980	49.72	30.85	7.45	24.69	51.01	74.00	-22.99	PK
V	22980	40.23	30.85	7.45	24.69	41.52	54.00	-12.48	AV
H	11490	48.55	30.55	5.77	24.66	48.43	74.00	-25.57	PK
H	11490	39.74	30.55	5.77	24.66	39.62	54.00	-14.38	AV
H	17235	47.65	30.33	6.32	24.55	48.19	74.00	-25.81	PK
H	17235	41.00	30.33	6.32	24.55	41.54	54.00	-12.46	AV
H	22980	49.33	30.85	7.45	24.69	50.62	74.00	-23.38	PK
H	22980	39.33	30.85	7.45	24.69	40.62	54.00	-13.38	AV

Polar (H/V)	Frequency	Meter Reading	Pre-ampli fier	Cable Loss	Antenna Factor	Emission Level	Limits	Margin	Detect or Type
	(MHz)	(dBuV)	(dB)	(dB)	(dB)	(dBuV/m)	(dBuV/ m)	(dB)	
High Channel:5785MHz									
V	11570	48.40	30.55	5.77	24.66	48.28	74.00	-25.72	PK
V	11570	35.47	30.55	5.77	24.66	35.35	54.00	-18.65	AV
V	17355	48.19	30.33	6.32	24.55	48.73	74.00	-25.27	PK
V	17355	39.66	30.33	6.32	24.55	40.20	54.00	-13.80	AV
V	23140	51.13	30.85	7.45	24.69	52.42	74.00	-21.58	PK
V	23140	40.48	30.85	7.45	24.69	41.77	54.00	-12.23	AV
H	11570	48.10	30.55	5.77	24.66	47.98	74.00	-26.02	PK
H	11570	39.60	30.55	5.77	24.66	39.48	54.00	-14.52	AV
H	17355	48.68	30.33	6.32	24.55	49.22	74.00	-24.78	PK
H	17355	40.98	30.33	6.32	24.55	41.52	54.00	-12.48	AV
H	23140	49.83	30.85	7.45	24.69	51.12	74.00	-22.88	PK
H	23140	41.07	30.85	7.45	24.69	42.36	54.00	-11.64	AV

Polar (H/V)	Frequency	Meter Reading	Pre-ampli fier	Cable Loss	Antenna Factor	Emission Level	Limits	Margin	Detect or Type
	(MHz)	(dBuV)	(dB)	(dB)	(dB)	(dBuV/m)	(dBuV/ m)	(dB)	
High Channel:5825MHz									
V	11650	47.53	30.55	5.77	24.66	47.41	74.00	-26.59	PK
V	11650	35.67	30.55	5.77	24.66	35.55	54.00	-18.45	AV
V	17475	48.71	30.33	6.32	24.55	49.25	74.00	-24.75	PK
V	17475	39.57	30.33	6.32	24.55	40.11	54.00	-13.89	AV
V	23300	49.98	30.85	7.45	24.69	51.27	74.00	-22.73	PK
V	23300	40.24	30.85	7.45	24.69	41.53	54.00	-12.47	AV
H	11650	48.57	30.55	5.77	24.66	48.45	74.00	-25.55	PK
H	11650	37.80	30.55	5.77	24.66	37.68	54.00	-16.32	AV
H	17475	48.65	30.33	6.32	24.55	49.19	74.00	-24.81	PK
H	17475	39.90	30.33	6.32	24.55	40.44	54.00	-13.56	AV
H	23300	51.34	30.85	7.45	24.69	52.63	74.00	-21.37	PK
H	23300	39.47	30.85	7.45	24.69	40.76	54.00	-13.24	AV

802.11n20

Polar (H/V)	Frequency	Meter Reading	Pre-ampl ifier	Cable Loss	Antenna Factor	Emission Level	Limits	Margin	Detect or Type
	(MHz)	(dBuV)	(dB)	(dB)	(dB)	(dBuV/m)	(dBuV/ m)	(dB)	
Low Channel:5180MHz									
V	10360	47.95	30.55	5.77	24.66	47.83	74.00	-26.17	PK
V	10360	34.69	30.55	5.77	24.66	34.57	54.00	-19.43	AV
V	15540	48.71	30.33	6.32	24.55	49.25	74.00	-24.75	PK
V	15540	39.95	30.33	6.32	24.55	40.49	54.00	-13.51	AV
V	20720	50.58	30.85	7.45	24.69	51.87	74.00	-22.13	PK
V	20720	39.57	30.85	7.45	24.69	40.86	54.00	-13.14	AV
H	10360	48.06	30.55	5.77	24.66	47.94	74.00	-26.06	PK
H	10360	39.36	30.55	5.77	24.66	39.24	54.00	-14.76	AV
H	15540	48.05	30.33	6.32	24.55	48.59	74.00	-25.41	PK
H	15540	41.25	30.33	6.32	24.55	41.79	54.00	-12.21	AV
H	20720	50.72	30.85	7.45	24.69	52.01	74.00	-21.99	PK
H	20720	41.41	30.85	7.45	24.69	42.70	54.00	-11.30	AV

Polar (H/V)	Frequency	Meter Reading	Pre-ampl ifier	Cable Loss	Antenna Factor	Emission Level	Limits	Margin	Detect or Type
	(MHz)	(dBuV)	(dB)	(dB)	(dB)	(dBuV/m)	(dBuV/ m)	(dB)	
Middle Channel:5200MHz									
V	10400	47.15	30.55	5.77	24.66	47.03	74.00	-26.97	PK
V	10400	33.90	30.55	5.77	24.66	33.78	54.00	-20.22	AV
V	15600	48.45	30.33	6.32	24.55	48.99	74.00	-25.01	PK
V	15600	40.72	30.33	6.32	24.55	41.26	54.00	-12.74	AV
V	20800	49.83	30.85	7.45	24.69	51.12	74.00	-22.88	PK
V	20800	40.45	30.85	7.45	24.69	41.74	54.00	-12.26	AV
H	10400	47.22	30.55	5.77	24.66	47.10	74.00	-26.90	PK
H	10400	39.08	30.55	5.77	24.66	38.96	54.00	-15.04	AV
H	15600	48.08	30.33	6.32	24.55	48.62	74.00	-25.38	PK
H	15600	41.42	30.33	6.32	24.55	41.96	54.00	-12.04	AV
H	20800	51.47	30.85	7.45	24.69	52.76	74.00	-21.24	PK
H	20800	40.38	30.85	7.45	24.69	41.67	54.00	-12.33	AV

Polar (H/V)	Frequency	Meter Reading	Pre-ampl ifier	Cable Loss	Antenna Factor	Emission Level	Limits	Margin	Detect or Type
	(MHz)	(dBuV)	(dB)	(dB)	(dB)	(dBuV/m)	(dBuV/ m)	(dB)	
High Channel:5240MHz									
V	10480	47.00	30.55	5.77	24.66	46.88	74.00	-27.12	PK
V	10480	34.56	30.55	5.77	24.66	34.44	54.00	-19.56	AV
V	15720	49.25	30.33	6.32	24.55	49.79	74.00	-24.21	PK
V	15720	40.25	30.33	6.32	24.55	40.79	54.00	-13.21	AV
V	20960	49.37	30.85	7.45	24.69	50.66	74.00	-23.34	PK
V	20960	41.32	30.85	7.45	24.69	42.61	54.00	-11.39	AV
H	10480	48.21	30.55	5.77	24.66	48.09	74.00	-25.91	PK
H	10480	39.27	30.55	5.77	24.66	39.15	54.00	-14.85	AV
H	15720	47.02	30.33	6.32	24.55	47.56	74.00	-26.44	PK
H	15720	39.84	30.33	6.32	24.55	40.38	54.00	-13.62	AV
H	20960	49.76	30.85	7.45	24.69	51.05	74.00	-22.95	PK
H	20960	39.92	30.85	7.45	24.69	41.21	54.00	-12.79	AV

Polar (H/V)	Frequency	Meter Reading	Pre-ampli fier	Cable Loss	Antenna Factor	Emission Level	Limits	Margin	Detect or Type
	(MHz)	(dBuV)	(dB)	(dB)	(dB)	(dBuV/m)	(dBuV/ m)	(dB)	
High Channel:5745MHz									
V	11490	49.67	30.55	5.77	24.66	49.55	74.00	-24.45	PK
V	11490	34.77	30.55	5.77	24.66	34.65	54.00	-19.35	AV
V	17235	49.31	30.33	6.32	24.55	49.85	74.00	-24.15	PK
V	17235	40.40	30.33	6.32	24.55	40.94	54.00	-13.06	AV
V	22980	51.28	30.85	7.45	24.69	52.57	74.00	-21.43	PK
V	22980	39.22	30.85	7.45	24.69	40.51	54.00	-13.49	AV
H	11490	46.64	30.55	5.77	24.66	46.52	74.00	-27.48	PK
H	11490	40.35	30.55	5.77	24.66	40.23	54.00	-13.77	AV
H	17235	47.55	30.33	6.32	24.55	48.09	74.00	-25.91	PK
H	17235	40.00	30.33	6.32	24.55	40.54	54.00	-13.46	AV
H	22980	51.32	30.85	7.45	24.69	52.61	74.00	-21.39	PK
H	22980	39.01	30.85	7.45	24.69	40.30	54.00	-13.70	AV

Polar (H/V)	Frequency	Meter Reading	Pre-ampli fier	Cable Loss	Antenna Factor	Emission Level	Limits	Margin	Detect or Type
	(MHz)	(dBuV)	(dB)	(dB)	(dB)	(dBuV/m)	(dBuV/ m)	(dB)	
High Channel:5785MHz									
V	11570	46.94	30.55	5.77	24.66	46.82	74.00	-27.18	PK
V	11570	34.50	30.55	5.77	24.66	34.38	54.00	-19.62	AV
V	17355	49.70	30.33	6.32	24.55	50.24	74.00	-23.76	PK
V	17355	40.00	30.33	6.32	24.55	40.54	54.00	-13.46	AV
V	23140	51.46	30.85	7.45	24.69	52.75	74.00	-21.25	PK
V	23140	39.34	30.85	7.45	24.69	40.63	54.00	-13.37	AV
H	11570	47.54	30.55	5.77	24.66	47.42	74.00	-26.58	PK
H	11570	38.63	30.55	5.77	24.66	38.51	54.00	-15.49	AV
H	17355	46.81	30.33	6.32	24.55	47.35	74.00	-26.65	PK
H	17355	39.85	30.33	6.32	24.55	40.39	54.00	-13.61	AV
H	23140	50.83	30.85	7.45	24.69	52.12	74.00	-21.88	PK
H	23140	40.23	30.85	7.45	24.69	41.52	54.00	-12.48	AV

Polar (H/V)	Frequency	Meter Reading	Pre-ampli fier	Cable Loss	Antenna Factor	Emission Level	Limits	Margin	Detect or Type
	(MHz)	(dBuV)	(dB)	(dB)	(dB)	(dBuV/m)	(dBuV/ m)	(dB)	
High Channel:5825MHz									
V	11650	47.70	30.55	5.77	24.66	47.58	74.00	-26.42	PK
V	11650	34.99	30.55	5.77	24.66	34.87	54.00	-19.13	AV
V	17475	48.26	30.33	6.32	24.55	48.80	74.00	-25.20	PK
V	17475	40.16	30.33	6.32	24.55	40.70	54.00	-13.30	AV
V	23300	50.67	30.85	7.45	24.69	51.96	74.00	-22.04	PK
V	23300	39.27	30.85	7.45	24.69	40.56	54.00	-13.44	AV
H	11650	46.64	30.55	5.77	24.66	46.52	74.00	-27.48	PK
H	11650	39.11	30.55	5.77	24.66	38.99	54.00	-15.01	AV
H	17475	48.25	30.33	6.32	24.55	48.79	74.00	-25.21	PK
H	17475	40.05	30.33	6.32	24.55	40.59	54.00	-13.41	AV
H	23300	50.45	30.85	7.45	24.69	51.74	74.00	-22.26	PK
H	23300	41.36	30.85	7.45	24.69	42.65	54.00	-11.35	AV

802.11n40

Polar (H/V)	Frequency	Meter Reading	Pre-ampl ifier	Cable Loss	Antenna Factor	Emission Level	Limits	Margin	Detect or Type
	(MHz)	(dBuV)	(dB)	(dB)	(dB)	(dBuV/m)	(dBuV/ m)	(dB)	
Low Channel:5190MHz									
V	10360	48.35	30.55	5.77	24.66	48.23	74.00	-25.77	PK
V	10360	34.70	30.55	5.77	24.66	34.58	54.00	-19.42	AV
V	15540	48.82	30.33	6.32	24.55	49.36	74.00	-24.64	PK
V	15540	40.66	30.33	6.32	24.55	41.20	54.00	-12.80	AV
V	20720	49.07	30.85	7.45	24.69	50.36	74.00	-23.64	PK
V	20720	38.84	30.85	7.45	24.69	40.13	54.00	-13.87	AV
H	10360	46.27	30.55	5.77	24.66	46.15	74.00	-27.85	PK
H	10360	38.19	30.55	5.77	24.66	38.07	54.00	-15.93	AV
H	15540	48.05	30.33	6.32	24.55	48.59	74.00	-25.41	PK
H	15540	40.88	30.33	6.32	24.55	41.42	54.00	-12.58	AV
H	20720	50.54	30.85	7.45	24.69	51.83	74.00	-22.17	PK
H	20720	39.69	30.85	7.45	24.69	40.98	54.00	-13.02	AV

Polar (H/V)	Frequency	Meter Reading	Pre-ampl ifier	Cable Loss	Antenna Factor	Emission Level	Limits	Margin	Detect or Type
	(MHz)	(dBuV)	(dB)	(dB)	(dB)	(dBuV/m)	(dBuV/ m)	(dB)	
Middle Channel:5230MHz									
V	10460	47.27	30.55	5.77	24.66	47.15	74.00	-26.85	PK
V	10460	34.47	30.55	5.77	24.66	34.35	54.00	-19.65	AV
V	15690	49.53	30.33	6.32	24.55	50.07	74.00	-23.93	PK
V	15690	39.97	30.33	6.32	24.55	40.51	54.00	-13.49	AV
V	20920	49.98	30.85	7.45	24.69	51.27	74.00	-22.73	PK
V	20920	39.20	30.85	7.45	24.69	40.49	54.00	-13.51	AV
H	10460	46.35	30.55	5.77	24.66	46.23	74.00	-27.77	PK
H	10460	40.20	30.55	5.77	24.66	40.08	54.00	-13.92	AV
H	15690	46.85	30.33	6.32	24.55	47.39	74.00	-26.61	PK
H	15690	40.36	30.33	6.32	24.55	40.90	54.00	-13.10	AV
H	20920	51.75	30.85	7.45	24.69	53.04	74.00	-20.96	PK
H	20920	40.96	30.85	7.45	24.69	42.25	54.00	-11.75	AV

Polar (H/V)	Frequency	Meter Reading	Pre-ampli fier	Cable Loss	Antenna Factor	Emission Level	Limits	Margin	Detect or Type
	(MHz)	(dBuV)	(dB)	(dB)	(dB)	(dBuV/m)	(dBuV/ m)	(dB)	
High Channel:5755MHz									
V	11510	48.41	30.55	5.77	24.66	48.29	74.00	-25.71	PK
V	11510	33.89	30.55	5.77	24.66	33.77	54.00	-20.23	AV
V	17265	48.90	30.33	6.32	24.55	49.44	74.00	-24.56	PK
V	17265	39.23	30.33	6.32	24.55	39.77	54.00	-14.23	AV
V	23020	51.37	30.85	7.45	24.69	52.66	74.00	-21.34	PK
V	23020	39.49	30.85	7.45	24.69	40.78	54.00	-13.22	AV
H	11510	46.99	30.55	5.77	24.66	46.87	74.00	-27.13	PK
H	11510	40.48	30.55	5.77	24.66	40.36	54.00	-13.64	AV
H	17265	48.43	30.33	6.32	24.55	48.97	74.00	-25.03	PK
H	17265	41.58	30.33	6.32	24.55	42.12	54.00	-11.88	AV
H	23020	49.89	30.85	7.45	24.69	51.18	74.00	-22.82	PK
H	23020	39.17	30.85	7.45	24.69	40.46	54.00	-13.54	AV

Polar (H/V)	Frequency	Meter Reading	Pre-ampli fier	Cable Loss	Antenna Factor	Emission Level	Limits	Margin	Detect or Type
	(MHz)	(dBuV)	(dB)	(dB)	(dB)	(dBuV/m)	(dBuV/ m)	(dB)	
High Channel:5795MHz									
V	11590	49.35	30.55	5.77	24.66	49.23	74.00	-24.77	PK
V	11590	34.45	30.55	5.77	24.66	34.33	54.00	-19.67	AV
V	17385	49.13	30.33	6.32	24.55	49.67	74.00	-24.33	PK
V	17385	39.63	30.33	6.32	24.55	40.17	54.00	-13.83	AV
V	23180	51.11	30.85	7.45	24.69	52.40	74.00	-21.60	PK
V	23180	40.33	30.85	7.45	24.69	41.62	54.00	-12.38	AV
H	11590	47.17	30.55	5.77	24.66	47.05	74.00	-26.95	PK
H	11590	40.68	30.55	5.77	24.66	40.56	54.00	-13.44	AV
H	17385	47.47	30.33	6.32	24.55	48.01	74.00	-25.99	PK
H	17385	38.83	30.33	6.32	24.55	39.37	54.00	-14.63	AV
H	23180	49.94	30.85	7.45	24.69	51.23	74.00	-22.77	PK
H	23180	41.42	30.85	7.45	24.69	42.71	54.00	-11.29	AV

Remark:

1. Emission Level = Meter Reading + Antenna Factor + Cable Loss – Pre-amplifier,
Margin= Emission Level - Limit
2. If peak below the average limit, the average emission was no test.
3. The amplitude of spurious emissions which are attenuated by more than 20dB below the permissible value has no need to be reported.

802.11ac20

Polar (H/V)	Frequency	Meter Reading	Pre-ampli fier	Cable Loss	Antenna Factor	Emission Level	Limits	Margin	Detect or Type
	(MHz)	(dBuV)	(dB)	(dB)	(dB)	(dBuV/m)	(dBuV/ m)	(dB)	
Low Channel:5180MHz									
V	10360	46.80	30.55	5.77	24.66	46.68	74.00	-27.32	PK
V	10360	34.31	30.55	5.77	24.66	34.19	54.00	-19.81	AV
V	15540	49.43	30.33	6.32	24.55	49.97	74.00	-24.03	PK
V	15540	39.71	30.33	6.32	24.55	40.25	54.00	-13.75	AV
V	20720	48.87	30.85	7.45	24.69	50.16	74.00	-23.84	PK
V	20720	39.72	30.85	7.45	24.69	41.01	54.00	-12.99	AV
H	10360	46.19	30.55	5.77	24.66	46.07	74.00	-27.93	PK
H	10360	40.66	30.55	5.77	24.66	40.54	54.00	-13.46	AV
H	15540	47.24	30.33	6.32	24.55	47.78	74.00	-26.22	PK
H	15540	38.99	30.33	6.32	24.55	39.53	54.00	-14.47	AV
H	20720	50.87	30.85	7.45	24.69	52.16	74.00	-21.84	PK
H	20720	39.64	30.85	7.45	24.69	40.93	54.00	-13.07	AV

Polar (H/V)	Frequency	Meter Reading	Pre-ampli fier	Cable Loss	Antenna Factor	Emission Level	Limits	Margin	Detect or Type
	(MHz)	(dBuV)	(dB)	(dB)	(dB)	(dBuV/m)	(dBuV/ m)	(dB)	
Middle Channel:5200MHz									
V	10400	48.49	30.55	5.77	24.66	48.37	74.00	-25.63	PK
V	10400	35.45	30.55	5.77	24.66	35.33	54.00	-18.67	AV
V	15600	47.85	30.33	6.32	24.55	48.39	74.00	-25.61	PK

V	15600	41.64	30.33	6.32	24.55	42.18	54.00	-11.82	AV
V	20800	51.51	30.85	7.45	24.69	52.80	74.00	-21.20	PK
V	20800	41.52	30.85	7.45	24.69	42.81	54.00	-11.19	AV
H	10400	45.83	30.55	5.77	24.66	45.71	74.00	-28.29	PK
H	10400	39.08	30.55	5.77	24.66	38.96	54.00	-15.04	AV
H	15600	47.61	30.33	6.32	24.55	48.15	74.00	-25.85	PK
H	15600	39.42	30.33	6.32	24.55	39.96	54.00	-14.04	AV
H	20800	50.75	30.85	7.45	24.69	52.04	74.00	-21.96	PK
H	20800	39.81	30.85	7.45	24.69	41.10	54.00	-12.90	AV

Polar (H/V)	Frequency	Meter Reading	Pre-amplifier	Cable Loss	Antenna Factor	Emission Level	Limits	Margin	Detect or Type
	(MHz)	(dBuV)	(dB)	(dB)	(dB)	(dBuV/m)	(dBuV/m)	(dB)	
High Channel:5240MHz									
V	10480	48.67	30.55	5.77	24.66	48.55	74.00	-25.45	PK
V	10480	35.52	30.55	5.77	24.66	35.40	54.00	-18.60	AV
V	15720	49.20	30.33	6.32	24.55	49.74	74.00	-24.26	PK
V	15720	40.11	30.33	6.32	24.55	40.65	54.00	-13.35	AV
V	20960	50.77	30.85	7.45	24.69	52.06	74.00	-21.94	PK
V	20960	41.36	30.85	7.45	24.69	42.65	54.00	-11.35	AV
H	10480	47.01	30.55	5.77	24.66	46.89	74.00	-27.11	PK
H	10480	38.76	30.55	5.77	24.66	38.64	54.00	-15.36	AV
H	15720	46.81	30.33	6.32	24.55	47.35	74.00	-26.65	PK
H	15720	39.91	30.33	6.32	24.55	40.45	54.00	-13.55	AV
H	20960	49.09	30.85	7.45	24.69	50.38	74.00	-23.62	PK
H	20960	40.96	30.85	7.45	24.69	42.25	54.00	-11.75	AV

Polar (H/V)	Frequency	Meter Reading	Pre-amplifier	Cable Loss	Antenna Factor	Emission Level	Limits	Margin	Detect or Type
	(MHz)	(dBuV)	(dB)	(dB)	(dB)	(dBuV/m)	(dBuV/m)	(dB)	
High Channel:5745MHz									
V	11490	47.70	30.55	5.77	24.66	47.58	74.00	-26.42	PK
V	11490	36.35	30.55	5.77	24.66	36.23	54.00	-17.77	AV
V	17235	49.42	30.33	6.32	24.55	49.96	74.00	-24.04	PK
V	17235	39.99	30.33	6.32	24.55	40.53	54.00	-13.47	AV
V	22980	50.06	30.85	7.45	24.69	51.35	74.00	-22.65	PK
V	22980	40.05	30.85	7.45	24.69	41.34	54.00	-12.66	AV
H	11490	47.58	30.55	5.77	24.66	47.46	74.00	-26.54	PK
H	11490	37.91	30.55	5.77	24.66	37.79	54.00	-16.21	AV
H	17235	47.24	30.33	6.32	24.55	47.78	74.00	-26.22	PK
H	17235	40.45	30.33	6.32	24.55	40.99	54.00	-13.01	AV
H	22980	49.31	30.85	7.45	24.69	50.60	74.00	-23.40	PK
H	22980	41.45	30.85	7.45	24.69	42.74	54.00	-11.26	AV

Polar (H/V)	Frequency	Meter Reading	Pre-amplifier	Cable Loss	Antenna Factor	Emission Level	Limits	Margin	Detect or Type
	(MHz)	(dBuV)	(dB)	(dB)	(dB)	(dBuV/m)	(dBuV/m)	(dB)	
High Channel:5785MHz									
V	11570	49.02	30.55	5.77	24.66	48.90	74.00	-25.10	PK
V	11570	36.50	30.55	5.77	24.66	36.38	54.00	-17.62	AV

V	17355	48.89	30.33	6.32	24.55	49.43	74.00	-24.57	PK
V	17355	40.94	30.33	6.32	24.55	41.48	54.00	-12.52	AV
V	23140	49.94	30.85	7.45	24.69	51.23	74.00	-22.77	PK
V	23140	39.28	30.85	7.45	24.69	40.57	54.00	-13.43	AV
H	11570	46.35	30.55	5.77	24.66	46.23	74.00	-27.77	PK
H	11570	37.85	30.55	5.77	24.66	37.73	54.00	-16.27	AV
H	17355	47.97	30.33	6.32	24.55	48.51	74.00	-25.49	PK
H	17355	39.64	30.33	6.32	24.55	40.18	54.00	-13.82	AV
H	23140	49.11	30.85	7.45	24.69	50.40	74.00	-23.60	PK
H	23140	38.83	30.85	7.45	24.69	40.12	54.00	-13.88	AV

Polar (H/V)	Frequency	Meter Reading	Pre-ampli fier	Cable Loss	Antenna Factor	Emission Level	Limits	Margin	Detect or Type
	(MHz)	(dBuV)	(dB)	(dB)	(dB)	(dBuV/m)	(dBuV/ m)	(dB)	
High Channel:5825MHz									
V	11650	49.69	30.55	5.77	24.66	49.57	74.00	-24.43	PK
V	11650	35.31	30.55	5.77	24.66	35.19	54.00	-18.81	AV
V	17475	48.46	30.33	6.32	24.55	49.00	74.00	-25.00	PK
V	17475	39.37	30.33	6.32	24.55	39.91	54.00	-14.09	AV
V	23300	49.68	30.85	7.45	24.69	50.97	74.00	-23.03	PK
V	23300	39.53	30.85	7.45	24.69	40.82	54.00	-13.18	AV
H	11650	48.21	30.55	5.77	24.66	48.09	74.00	-25.91	PK
H	11650	39.73	30.55	5.77	24.66	39.61	54.00	-14.39	AV
H	17475	47.15	30.33	6.32	24.55	47.69	74.00	-26.31	PK
H	17475	38.84	30.33	6.32	24.55	39.38	54.00	-14.62	AV
H	23300	51.18	30.85	7.45	24.69	52.47	74.00	-21.53	PK
H	23300	39.40	30.85	7.45	24.69	40.69	54.00	-13.31	AV

ANT1-802.11ac40

Polar (H/V)	Frequency	Meter Reading	Pre-ampli fier	Cable Loss	Antenna Factor	Emission Level	Limits	Margin	Detect or Type
	(MHz)	(dBuV)	(dB)	(dB)	(dB)	(dBuV/m)	(dBuV/ m)	(dB)	
Low Channel:5190MHz									
V	10360	47.49	30.55	5.77	24.66	47.37	74.00	-26.63	PK
V	10360	35.47	30.55	5.77	24.66	35.35	54.00	-18.65	AV
V	15540	49.61	30.33	6.32	24.55	50.15	74.00	-23.85	PK
V	15540	41.14	30.33	6.32	24.55	41.68	54.00	-12.32	AV
V	20720	48.81	30.85	7.45	24.69	50.10	74.00	-23.90	PK
V	20720	39.25	30.85	7.45	24.69	40.54	54.00	-13.46	AV
H	10360	47.04	30.55	5.77	24.66	46.92	74.00	-27.08	PK
H	10360	40.50	30.55	5.77	24.66	40.38	54.00	-13.62	AV
H	15540	47.18	30.33	6.32	24.55	47.72	74.00	-26.28	PK
H	15540	40.41	30.33	6.32	24.55	40.95	54.00	-13.05	AV
H	20720	49.44	30.85	7.45	24.69	50.73	74.00	-23.27	PK
H	20720	41.59	30.85	7.45	24.69	42.88	54.00	-11.12	AV

Polar (H/V)	Frequency	Meter Reading	Pre-ampli fier	Cable Loss	Antenna Factor	Emission Level	Limits	Margin	Detect or Type
	(MHz)	(dBuV)	(dB)	(dB)	(dB)	(dBuV/m)	(dBuV/ m)	(dB)	
Middle Channel:5230MHz									
V	10460	49.44	30.55	5.77	24.66	49.32	74.00	-24.68	PK
V	10460	34.87	30.55	5.77	24.66	34.75	54.00	-19.25	AV
V	15690	47.89	30.33	6.32	24.55	48.43	74.00	-25.57	PK
V	15690	41.12	30.33	6.32	24.55	41.66	54.00	-12.34	AV
V	20920	49.44	30.85	7.45	24.69	50.73	74.00	-23.27	PK
V	20920	39.08	30.85	7.45	24.69	40.37	54.00	-13.63	AV
H	10460	47.58	30.55	5.77	24.66	47.46	74.00	-26.54	PK
H	10460	39.71	30.55	5.77	24.66	39.59	54.00	-14.41	AV
H	15690	47.55	30.33	6.32	24.55	48.09	74.00	-25.91	PK
H	15690	39.65	30.33	6.32	24.55	40.19	54.00	-13.81	AV
H	20920	51.74	30.85	7.45	24.69	53.03	74.00	-20.97	PK
H	20920	38.77	30.85	7.45	24.69	40.06	54.00	-13.94	AV

Polar (H/V)	Frequency	Meter Reading	Pre-ampli fier	Cable Loss	Antenna Factor	Emission Level	Limits	Margin	Detect or Type
	(MHz)	(dBuV)	(dB)	(dB)	(dB)	(dBuV/m)	(dBuV/ m)	(dB)	
High Channel:5755MHz									
V	11510	48.03	30.55	5.77	24.66	47.91	74.00	-26.09	PK
V	11510	36.08	30.55	5.77	24.66	35.96	54.00	-18.04	AV
V	17265	48.10	30.33	6.32	24.55	48.64	74.00	-25.36	PK
V	17265	40.39	30.33	6.32	24.55	40.93	54.00	-13.07	AV
V	23020	51.20	30.85	7.45	24.69	52.49	74.00	-21.51	PK
V	23020	40.31	30.85	7.45	24.69	41.60	54.00	-12.40	AV
H	11510	45.96	30.55	5.77	24.66	45.84	74.00	-28.16	PK
H	11510	38.25	30.55	5.77	24.66	38.13	54.00	-15.87	AV
H	17265	47.72	30.33	6.32	24.55	48.26	74.00	-25.74	PK
H	17265	41.54	30.33	6.32	24.55	42.08	54.00	-11.92	AV
H	23020	49.18	30.85	7.45	24.69	50.47	74.00	-23.53	PK
H	23020	39.90	30.85	7.45	24.69	41.19	54.00	-12.81	AV

Polar (H/V)	Frequency	Meter Reading	Pre-ampli fier	Cable Loss	Antenna Factor	Emission Level	Limits	Margin	Detect or Type
	(MHz)	(dBuV)	(dB)	(dB)	(dB)	(dBuV/m)	(dBuV/ m)	(dB)	
High Channel:5795MHz									
V	11510	48.27	30.55	5.77	24.66	48.15	74.00	-25.85	PK
V	11510	34.85	30.55	5.77	24.66	34.73	54.00	-19.27	AV
V	17265	49.29	30.33	6.32	24.55	49.83	74.00	-24.17	PK
V	17265	39.79	30.33	6.32	24.55	40.33	54.00	-13.67	AV
V	23020	50.53	30.85	7.45	24.69	51.82	74.00	-22.18	PK
V	23020	40.80	30.85	7.45	24.69	42.09	54.00	-11.91	AV
H	11510	46.38	30.55	5.77	24.66	46.26	74.00	-27.74	PK
H	11510	40.36	30.55	5.77	24.66	40.24	54.00	-13.76	AV
H	17265	47.93	30.33	6.32	24.55	48.47	74.00	-25.53	PK
H	17265	39.96	30.33	6.32	24.55	40.50	54.00	-13.50	AV
H	23020	48.87	30.85	7.45	24.69	50.16	74.00	-23.84	PK
H	23020	40.45	30.85	7.45	24.69	41.74	54.00	-12.26	AV

802.11ac80

Polar (H/V)	Frequency	Meter Reading	Pre-amplifier	Cable Loss	Antenna Factor	Emission Level	Limits	Margin	Detect or Type
	(MHz)	(dBuV)	(dB)	(dB)	(dB)	(dBuV/m)	(dBuV/m)	(dB)	
5210MHz									
V	10420	49.26	30.55	5.77	24.66	49.14	74.00	-24.86	PK
V	10420	35.37	30.55	5.77	24.66	35.25	54.00	-18.75	AV
V	15630	48.77	30.33	6.32	24.55	49.31	74.00	-24.69	PK
V	15630	40.64	30.33	6.32	24.55	41.18	54.00	-12.82	AV
V	20840	51.23	30.85	7.45	24.69	52.52	74.00	-21.48	PK
V	20840	39.01	30.85	7.45	24.69	40.30	54.00	-13.70	AV
H	10420	47.97	30.55	5.77	24.66	47.85	74.00	-26.15	PK
H	10420	38.87	30.55	5.77	24.66	38.75	54.00	-15.25	AV
H	15630	47.91	30.33	6.32	24.55	48.45	74.00	-25.55	PK
H	15630	40.76	30.33	6.32	24.55	41.30	54.00	-12.70	AV
H	20840	50.46	30.85	7.45	24.69	51.75	74.00	-22.25	PK
H	20840	39.29	30.85	7.45	24.69	40.58	54.00	-13.42	AV

Polar (H/V)	Frequency	Meter Reading	Pre-amplifier	Cable Loss	Antenna Factor	Emission Level	Limits	Margin	Detect or Type
	(MHz)	(dBuV)	(dB)	(dB)	(dB)	(dBuV/m)	(dBuV/m)	(dB)	
High Channel:5775MHz									
V	11550	48.48	30.55	5.77	24.66	48.36	74.00	-25.64	PK
V	11550	34.95	30.55	5.77	24.66	34.83	54.00	-19.17	AV
V	17325	48.41	30.33	6.32	24.55	48.95	74.00	-25.05	PK
V	17325	39.20	30.33	6.32	24.55	39.74	54.00	-14.26	AV
V	23100	49.79	30.85	7.45	24.69	51.08	74.00	-22.92	PK
V	23100	39.01	30.85	7.45	24.69	40.30	54.00	-13.70	AV
H	11550	46.56	30.55	5.77	24.66	46.44	74.00	-27.56	PK
H	11550	40.13	30.55	5.77	24.66	40.01	54.00	-13.99	AV
H	17325	47.22	30.33	6.32	24.55	47.76	74.00	-26.24	PK
H	17325	41.64	30.33	6.32	24.55	42.18	54.00	-11.82	AV
H	23100	51.40	30.85	7.45	24.69	52.69	74.00	-21.31	PK
H	23100	39.13	30.85	7.45	24.69	40.42	54.00	-13.58	AV

Remark:

1. Emission Level = Meter Reading + Antenna Factor + Cable Loss – Pre-amplifier,
Margin= Emission Level - Limit
2. If peak below the average limit, the average emission was no test.
3. The amplitude of spurious emissions which are attenuated by more than 20dB below the permissible value has no need to be reported.

Radiated Band Edge Test:

Worse case mode:		802.11a		Test channel:		36	
Frequency	Meter Reading	Factor	Emission Level	Limits	Over	Detector Type	Ant. Pol.
(MHz)	(dB μ V)	(dB)	(dB μ V/m)	(dB μ V/m)	(dB)		H/V
5150	53.70	-0.12	53.58	74.00	-20.42	peak	H
5150	41.09	-0.12	40.97	54.00	-13.03	AV	H
5150	53.28	-0.12	53.16	74.00	-20.84	peak	V
5150	39.77	-0.12	39.65	54.00	-14.35	AV	V

Worse case mode:		802.11a		Test channel:		48	
Frequency	Meter Reading	Factor	Emission Level	Limits	Over	Detector Type	Ant. Pol.
(MHz)	(dB μ V)	(dB)	(dB μ V/m)	(dB μ V/m)	(dB)		H/V
5250	52.57	-0.12	52.45	74.00	-21.55	peak	H
5250	39.62	-0.12	39.50	54.00	-14.50	AV	H
5250	56.08	-0.12	55.96	74.00	-18.04	peak	V
5250	38.95	-0.12	38.83	54.00	-15.17	AV	V

Worse case mode:		802.11a		Test channel:		149	
Frequency	Meter Reading	Factor	Emission Level	Limits	Over	Detector Type	Ant. Pol.
(MHz)	(dB μ V)	(dB)	(dB μ V/m)	(dB μ V/m)	(dB)		H/V
5650	50.36	-0.12	50.24	68.20	-17.96	peak	H
5700	84.92	-0.12	84.80	105.20	-20.40	peak	H
5720	87.83	-0.12	87.71	110.80	-23.09	peak	H
5725	96.52	-0.12	96.40	122.20	-25.80	peak	H
5650	50.86	-0.12	50.74	68.20	-17.46	peak	V
5700	83.72	-0.12	83.60	105.20	-21.60	peak	V
5720	87.91	-0.12	87.79	110.80	-23.01	peak	V
5725	96.27	-0.12	96.15	122.20	-26.05	peak	V

Worse case mode:		802.11a		Test channel:		165	
Frequency	Meter Reading	Factor	Emission Level	Limits	Over	Detector Type	Ant. Pol.
(MHz)	(dB μ V)	(dB)	(dB μ V/m)	(dB μ V/m)	(dB)		H/V
5850	96.34	-0.12	96.22	122.20	-25.98	peak	H
5855	88.49	-0.12	88.37	110.80	-22.43	peak	H
5875	86.68	-0.12	86.56	105.20	-18.64	peak	H
5925	47.99	-0.12	47.87	68.20	-20.33	peak	H
5850	95.50	-0.12	95.38	122.20	-26.82	peak	V
5855	88.28	-0.12	88.16	110.80	-22.64	peak	V
5875	82.59	-0.12	82.47	105.20	-22.73	peak	V
5925	48.14	-0.12	48.02	68.20	-20.18	peak	V

Worse case mode:		802.11n20		Test channel:		36	
Frequency	Meter Reading	Factor	Emission Level	Limits	Over	Detector Type	Ant. Pol.
(MHz)	(dB μ V)	(dB)	(dB μ V/m)	(dB μ V/m)	(dB)		H/V
5150	54.72	-0.12	54.60	74.00	-19.40	peak	H
5150	40.05	-0.12	39.93	54.00	-14.07	AV	H
5150	52.64	-0.12	52.52	74.00	-21.48	peak	V
5150	37.92	-0.12	37.80	54.00	-16.20	AV	V

Worse case mode:		802.11n20		Test channel:		48	
Frequency	Meter Reading	Factor	Emission Level	Limits	Over	Detector Type	Ant. Pol.
(MHz)	(dB μ V)	(dB)	(dB μ V/m)	(dB μ V/m)	(dB)		H/V
5250	54.37	-0.12	54.25	74.00	-19.75	peak	H
5250	41.92	-0.12	41.80	54.00	-12.20	AV	H
5250	53.64	-0.12	53.52	74.00	-20.48	peak	V
5250	39.06	-0.12	38.94	54.00	-15.06	AV	V

Worse case mode:		802.11n20		Test channel:		149	
Frequency	Meter Reading	Factor	Emission Level	Limits	Over	Detector Type	Ant. Pol.
(MHz)	(dB μ V)	(dB)	(dB μ V/m)	(dB μ V/m)	(dB)		H/V
5650	48.10	-0.12	47.98	68.20	-20.22	peak	H
5700	84.46	-0.12	84.34	105.20	-20.86	peak	H
5720	88.65	-0.12	88.53	110.80	-22.27	peak	H
5725	98.14	-0.12	98.02	122.20	-24.18	peak	H
5650	49.81	-0.12	49.69	68.20	-18.51	peak	V
5700	83.75	-0.12	83.63	105.20	-21.57	peak	V
5720	87.69	-0.12	87.57	110.80	-23.23	peak	V
5725	95.92	-0.12	95.80	122.20	-26.40	peak	V

Worse case mode:		802.11n20		Test channel:		165	
Frequency	Meter Reading	Factor	Emission Level	Limits	Over	Detector Type	Ant. Pol.
(MHz)	(dB μ V)	(dB)	(dB μ V/m)	(dB μ V/m)	(dB)		H/V
5850	94.67	-0.12	94.55	122.20	-27.65	peak	H
5855	85.34	-0.12	85.22	110.80	-25.58	peak	H
5875	86.62	-0.12	86.50	105.20	-18.70	peak	H
5925	47.84	-0.12	47.72	68.20	-20.48	peak	H
5850	95.59	-0.12	95.47	122.20	-26.73	peak	V
5855	85.05	-0.12	84.93	110.80	-25.87	peak	V
5875	82.89	-0.12	82.77	105.20	-22.43	peak	V
5925	48.52	-0.12	48.40	68.20	-19.80	peak	V

Worse case mode:		802.11n40		Test channel:		38	
Frequency	Meter Reading	Factor	Emission Level	Limits	Over	Detector Type	Ant. Pol.
(MHz)	(dB μ V)	(dB)	(dB μ V/m)	(dB μ V/m)	(dB)		H/V
5150	52.21	-0.12	52.09	74.00	-21.91	peak	H
5150	39.83	-0.12	39.71	54.00	-14.29	AV	H
5150	54.96	-0.12	54.84	74.00	-19.16	peak	V
5150	39.92	-0.12	39.80	54.00	-14.20	AV	V

Worse case mode:		802.11n40		Test channel:		46	
Frequency	Meter Reading	Factor	Emission Level	Limits	Over	Detector Type	Ant. Pol.
(MHz)	(dB μ V)	(dB)	(dB μ V/m)	(dB μ V/m)	(dB)		H/V
5250	54.81	-0.12	54.69	74.00	-19.31	peak	H
5250	39.73	-0.12	39.61	54.00	-14.39	AV	H
5250	54.46	-0.12	54.34	74.00	-19.66	peak	V
5250	39.20	-0.12	39.08	54.00	-14.92	AV	V

Worse case mode:		802.11n40		Test channel:		151	
Frequency	Meter Reading	Factor	Emission Level	Limits	Over	Detector Type	Ant. Pol.
(MHz)	(dB μ V)	(dB)	(dB μ V/m)	(dB μ V/m)	(dB)		H/V
5650	50.22	-0.12	50.10	68.20	-18.10	peak	H
5700	82.57	-0.12	82.45	105.20	-22.75	peak	H
5720	88.34	-0.12	88.22	110.80	-22.58	peak	H
5725	96.38	-0.12	96.26	122.20	-25.94	peak	H
5650	49.81	-0.12	49.69	68.20	-18.51	peak	V
5700	84.62	-0.12	84.50	105.20	-20.70	peak	V
5720	89.16	-0.12	89.04	110.80	-21.76	peak	V
5725	96.96	-0.12	96.84	122.20	-25.36	peak	V

Worse case mode:		802.11n40		Test channel:		159	
Frequency	Meter Reading	Factor	Emission Level	Limits	Over	Detector Type	Ant. Pol.
(MHz)	(dB μ V)	(dB)	(dB μ V/m)	(dB μ V/m)	(dB)		H/V
5850	98.92	-0.12	98.80	122.20	-23.40	peak	H
5855	88.35	-0.12	88.23	110.80	-22.57	peak	H
5875	87.77	-0.12	87.65	105.20	-17.55	peak	H
5925	47.02	-0.12	46.90	68.20	-21.30	peak	H
5850	99.60	-0.12	99.48	122.20	-22.72	peak	V
5855	90.20	-0.12	90.08	110.80	-20.72	peak	V
5875	82.88	-0.12	82.76	105.20	-22.44	peak	V
5925	46.29	-0.12	46.17	68.20	-22.03	peak	V

Worse case mode:		802.11ac20		Test channel:		36	
Frequency	Meter Reading	Factor	Emission Level	Limits	Over	Detector Type	Ant. Pol.
(MHz)	(dB μ V)	(dB)	(dB μ V/m)	(dB μ V/m)	(dB)		H/V
5150	54.52	-0.12	54.40	74.00	-19.60	peak	H
5150	40.03	-0.12	39.91	54.00	-14.09	AV	H
5150	54.22	-0.12	54.10	74.00	-19.90	peak	V
5150	37.32	-0.12	37.20	54.00	-16.80	AV	V

Worse case mode:		802.11ac20		Test channel:		48	
Frequency	Meter Reading	Factor	Emission Level	Limits	Over	Detector Type	Ant. Pol.
(MHz)	(dB μ V)	(dB)	(dB μ V/m)	(dB μ V/m)	(dB)		H/V
5250	53.12	-0.12	53.00	74.00	-21.00	peak	H
5250	40.30	-0.12	40.18	54.00	-13.82	AV	H
5250	52.79	-0.12	52.67	74.00	-21.33	peak	V
5250	37.24	-0.12	37.12	54.00	-16.88	AV	V

Worse case mode:		802.11ac20		Test channel:		149	
Frequency	Meter Reading	Factor	Emission Level	Limits	Over	Detector Type	Ant. Pol.
(MHz)	(dB μ V)	(dB)	(dB μ V/m)	(dB μ V/m)	(dB)		H/V
5650	50.08	-0.12	49.96	68.20	-18.24	peak	H
5700	84.69	-0.12	84.57	105.20	-20.63	peak	H
5720	88.57	-0.12	88.45	110.80	-22.35	peak	H
5725	96.28	-0.12	96.16	122.20	-26.04	peak	H
5650	46.50	-0.12	46.38	68.20	-21.82	peak	V
5700	82.98	-0.12	82.86	105.20	-22.34	peak	V
5720	90.67	-0.12	90.55	110.80	-20.25	peak	V
5725	95.00	-0.12	94.88	122.20	-27.32	peak	V

Worse case mode:		802.11n20		Test channel:		165	
Frequency	Meter Reading	Factor	Emission Level	Limits	Over	Detector Type	Ant. Pol.
(MHz)	(dB μ V)	(dB)	(dB μ V/m)	(dB μ V/m)	(dB)		H/V
5850	99.30	-0.12	99.18	122.20	-23.02	peak	H
5855	83.63	-0.12	83.51	110.80	-27.29	peak	H
5875	87.36	-0.12	87.24	105.20	-17.96	peak	H
5925	45.34	-0.12	45.22	68.20	-22.98	peak	H
5850	99.97	-0.12	99.85	122.20	-22.35	peak	V
5855	86.12	-0.12	86.00	110.80	-24.80	peak	V
5875	81.67	-0.12	81.55	105.20	-23.65	peak	V
5925	46.52	-0.12	46.40	68.20	-21.80	peak	V

Worse case mode:		802.11ac40		Test channel:		38	
Frequency	Meter Reading	Factor	Emission Level	Limits	Over	Detector Type	Ant. Pol.
(MHz)	(dB μ V)	(dB)	(dB μ V/m)	(dB μ V/m)	(dB)		H/V
5150	53.45	-0.12	53.33	74.00	-20.67	peak	H
5150	39.73	-0.12	39.61	54.00	-14.39	AV	H
5150	53.81	-0.12	53.69	74.00	-20.31	peak	V
5150	40.68	-0.12	40.56	54.00	-13.44	AV	V

Worse case mode:		802.11ac40		Test channel:		46	
Frequency	Meter Reading	Factor	Emission Level	Limits	Over	Detector Type	Ant. Pol.
(MHz)	(dB μ V)	(dB)	(dB μ V/m)	(dB μ V/m)	(dB)		H/V
5250	55.00	-0.12	54.88	74.00	-19.12	peak	H
5250	38.41	-0.12	38.29	54.00	-15.71	AV	H
5250	53.28	-0.12	53.16	74.00	-20.84	peak	V
5250	39.78	-0.12	39.66	54.00	-14.34	AV	V

Worse case mode:		802.11ac40		Test channel:		151	
Frequency	Meter Reading	Factor	Emission Level	Limits	Over	Detector Type	Ant. Pol.
(MHz)	(dB μ V)	(dB)	(dB μ V/m)	(dB μ V/m)	(dB)		H/V
5650	50.38	-0.12	50.26	68.20	-17.94	peak	H
5700	82.85	-0.12	82.73	105.20	-22.47	peak	H
5720	89.47	-0.12	89.35	110.80	-21.45	peak	H
5725	98.74	-0.12	98.62	122.20	-23.58	peak	H
5650	50.17	-0.12	50.05	68.20	-18.15	peak	V
5700	82.40	-0.12	82.28	105.20	-22.92	peak	V
5720	90.55	-0.12	90.43	110.80	-20.37	peak	V
5725	96.53	-0.12	96.41	122.20	-25.79	peak	V

Worse case mode:		802.11ac40		Test channel:		159	
Frequency	Meter Reading	Factor	Emission Level	Limits	Over	Detector Type	Ant. Pol.
(MHz)	(dB μ V)	(dB)	(dB μ V/m)	(dB μ V/m)	(dB)		H/V
5850	97.56	-0.12	97.44	122.20	-24.76	peak	H
5855	85.30	-0.12	85.18	110.80	-25.62	peak	H
5875	86.75	-0.12	86.63	105.20	-18.57	peak	H
5925	46.34	-0.12	46.22	68.20	-21.98	peak	H
5850	99.68	-0.12	99.56	122.20	-22.64	peak	V
5855	85.80	-0.12	85.68	110.80	-25.12	peak	V
5875	83.85	-0.12	83.73	105.20	-21.47	peak	V
5925	49.14	-0.12	49.02	68.20	-19.18	peak	V

Worse case mode:		802.11ac80		Test channel:		42	
Frequency	Meter Reading	Factor	Emission Level	Limits	Over	Detector Type	Ant. Pol.
(MHz)	(dB μ V)	(dB)	(dB μ V/m)	(dB μ V/m)	(dB)		H/V
5150	53.58	-0.12	53.46	74.00	-20.54	peak	H
5150	38.83	-0.12	38.71	54.00	-15.29	AV	H
5150	54.28	-0.12	54.16	74.00	-19.84	peak	V
5150	38.94	-0.12	38.82	54.00	-15.18	AV	V
5250	54.58	-0.12	54.46	74.00	-19.54	peak	H
5250	40.35	-0.12	40.23	54.00	-13.77	AV	H
5250	52.50	-0.12	52.38	74.00	-21.62	peak	V
5250	39.64	-0.12	39.52	54.00	-14.48	AV	V

Worse case mode:		802.11ac80		Test channel:		155	
Frequency	Meter Reading	Factor	Emission Level	Limits	Over	Detector Type	Ant. Pol.
(MHz)	(dB μ V)	(dB)	(dB μ V/m)	(dB μ V/m)	(dB)		H/V
5650	47.69	-0.12	47.57	68.20	-20.63	peak	H
5700	83.03	-0.12	82.91	105.20	-22.29	peak	H
5720	88.82	-0.12	88.70	110.80	-22.10	peak	H
5725	96.37	-0.12	96.25	122.20	-25.95	peak	H
5650	49.23	-0.12	49.11	68.20	-19.09	peak	V
5700	83.15	-0.12	83.03	105.20	-22.17	peak	V
5720	87.81	-0.12	87.69	110.80	-23.11	peak	V
5725	95.53	-0.12	95.41	122.20	-26.79	peak	V
5850	98.99	-0.12	98.87	122.20	-23.33	peak	H
5855	85.71	-0.12	85.59	110.80	-25.21	peak	H
5875	86.70	-0.12	86.58	105.20	-18.62	peak	H
5925	46.56	-0.12	46.44	68.20	-21.76	peak	H
5850	95.04	-0.12	94.92	122.20	-27.28	peak	V
5855	86.48	-0.12	86.36	110.80	-24.44	peak	V
5875	81.50	-0.12	81.38	105.20	-23.82	peak	V
5925	49.88	-0.12	49.76	68.20	-18.44	peak	V

Factor =Antenna Factor + Cable Loss – Pre-amplifier

5. POWER SPECTRAL DENSITY TEST

Test Requirement:	FCC 47 CFR Part 15 Subpart E Section 15.407 (a)
Test Method:	KDB 789033 D02 v02r01

5.1 APPLIED PROCEDURES / LIMIT

For client devices in the 5.15-5.25 GHz band, the maximum conducted output power over the frequency band of operation shall not exceed 250 mW provided the maximum antenna gain does not exceed 6 dBi. In addition, the maximum power spectral density shall not exceed 11 dBm in any 1 megahertz band. If transmitting antennas of directional gain greater than 6 dBi are used, both the maximum conducted output power and the maximum power spectral density shall be reduced by the amount in dB that the directional gain of the antenna exceeds 6 dBi.

For the band 5.725-5.850 GHz, the maximum conducted output power over the frequency band of operation shall not exceed 1 W. In addition, the maximum power spectral density shall not exceed 30 dBm in any 500-kHz band. If transmitting antennas of directional gain greater than 6 dBi are used, both the maximum conducted output power and the maximum power spectral density shall be reduced by the amount in dB that the directional gain of the antenna exceeds 6 dBi.

LIMIT:	U-NII-1	11DBM/MHZ
	U-NII-3	30DBM/500KHZ

5.2 TEST PROCEDURE

1. Set analyzer center frequency to NII channel center frequency.
2. Set the span to 1.5 times the NII bandwidth.
3. Set the RBW to: 1MHz
4. Set the VBW $\geq 3 \times$ RBW.
5. Detector = peak.
6. Sweep time = auto couple.
7. Trace mode = max hold.
8. Allow trace to fully stabilize.
9. Use the peak marker function to determine the maximum amplitude level within the RBW.
10. If measured value exceeds limit, reduce RBW (no less than 3 kHz) and repeat.

5.3 DEVIATION FROM STANDARD

No deviation.

5.4 TEST SETUP

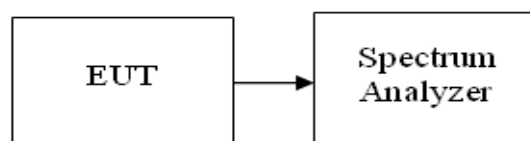

5.5 EUT OPERATION CONDITIONS

The EUT tested system was configured as the statements of 2.1 Unless otherwise a special operating condition is specified in the follows during the testing.

5.6 TEST RESULT

Temperature :	26°C	Relative Humidity :	54%
Pressure :	101kPa	Test Voltage :	DC5.0V
Test Mode :	TX frequency U-NII-1 & U-NII-3		

U-NII-1

802.11 Mode	Channel No.	Frequency [MHz]	Measured Power Spectral Density [dBm/MHz]	Power Spectral Density Limit [dBm/MHz]
a	36	5180	1.236	11
	40	5200	1.281	11
	48	5240	2.099	11
n(20MHz)	36	5180	-1.494	11
	40	5200	-0.584	11
	48	5240	0.036	11
ac (20MHz)	36	5180	-2.149	11
	40	5200	-2.190	11
	48	5240	-0.743	11
n (40MHz)	38	5190	-6.193	11
	46	5230	-6.005	11
ac(40MHz)	38	5190	-8.050	11
	46	5230	-6.292	11
ac(80MHz)	42	5210	-11.756	11

U-NII-3

802.11 Mode	Channel No.	Frequency [MHz]	PSD [dBm/1000kHz]	PSD [dBm/500kHz]	Limit [dBm/500kHz]
a	149	5745	1.733	-1.277	30
	157	5785	2.293	2.207	30
	165	5825	2.597	2.511	30
n (20MHz)	149	5745	0.987	0.901	30
	157	5785	0.674	0.588	30
	165	5825	2.531	2.445	30
ac (20MHz)	149	5745	1.846	1.760	30
	157	5785	2.055	1.969	30
	165	5825	1.893	1.807	30
n (40MHz)	151	5755	-2.095	-2.181	30
	159	5795	-2.602	-2.688	30
ac(40MHz)	151	5755	-1.953	-2.039	30
	159	5795	-3.062	-3.148	30
ac(80MHz)	155	5755	-10.375	-10.461	30

Note: Covert PSD [dBm/510KHz]= PSD[dBm/1000KHz]+ 10*log(500/1000)

U-NII-1

802.11a



802.11n (20MHz)



CH36-5180MHz



CH36-5180MHz



CH40-5200MHz



CH40-5200MHz



CH48-5240MHz



CH48-5240MHz



802.11ac 20MHz

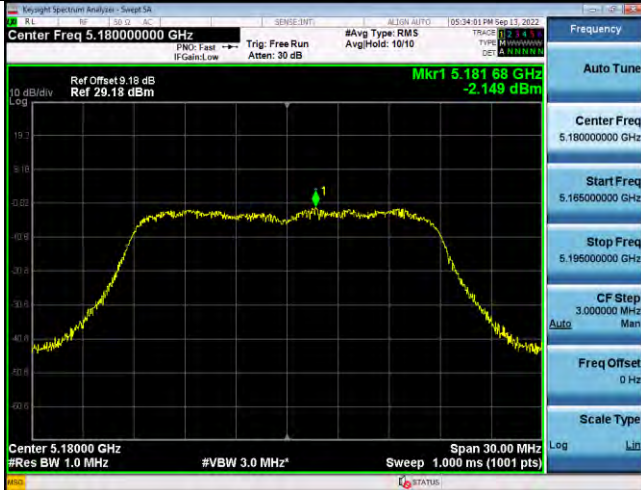

Frequency
Auto Tune
Center Freq 5.18000000 GHz
Start Freq 5.16500000 GHz
Stop Freq 5.19500000 GHz
CF Step 3.000000 MHz Auto Man
Freq Offset 0 Hz
Scale Type Log Lin

CH36-5180MHz



Frequency
Auto Tune
Center Freq 5.20000000 GHz
Start Freq 5.18500000 GHz
Stop Freq 5.21500000 GHz
CF Step 3.000000 MHz Auto Man
Freq Offset 0 Hz
Scale Type Log Lin

CH40-5200MHz



Frequency
Auto Tune
Center Freq 5.24000000 GHz
Start Freq 5.22500000 GHz
Stop Freq 5.25500000 GHz
CF Step 3.000000 MHz Auto Man
Freq Offset 0 Hz
Scale Type Log Lin

CH48-5240MHz

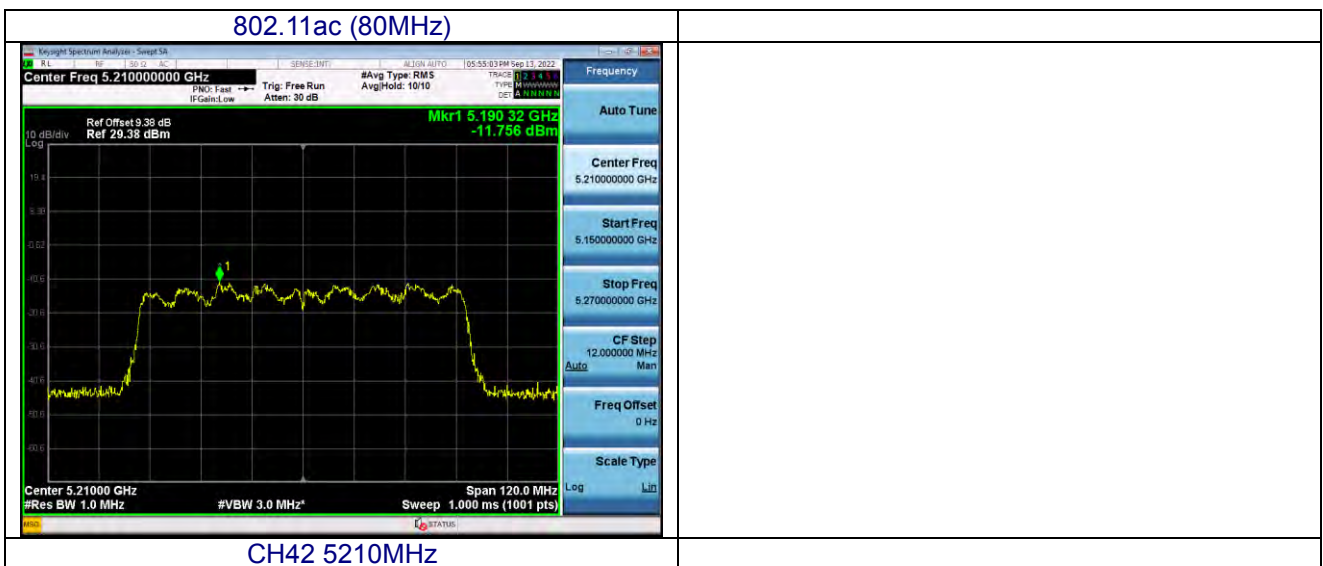
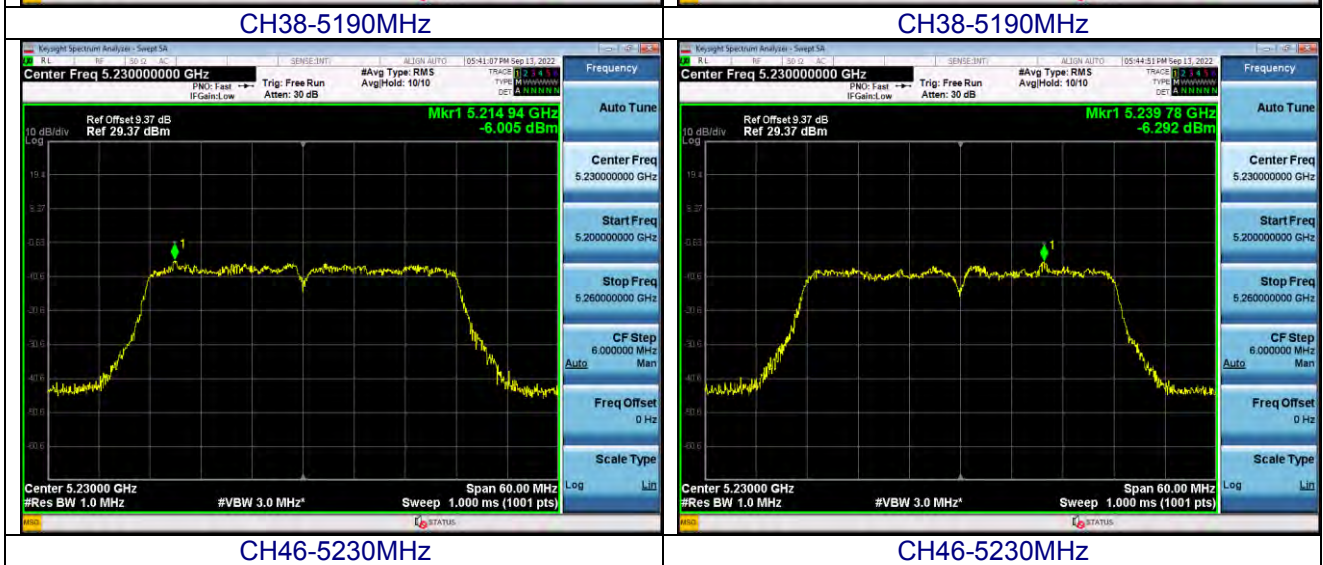
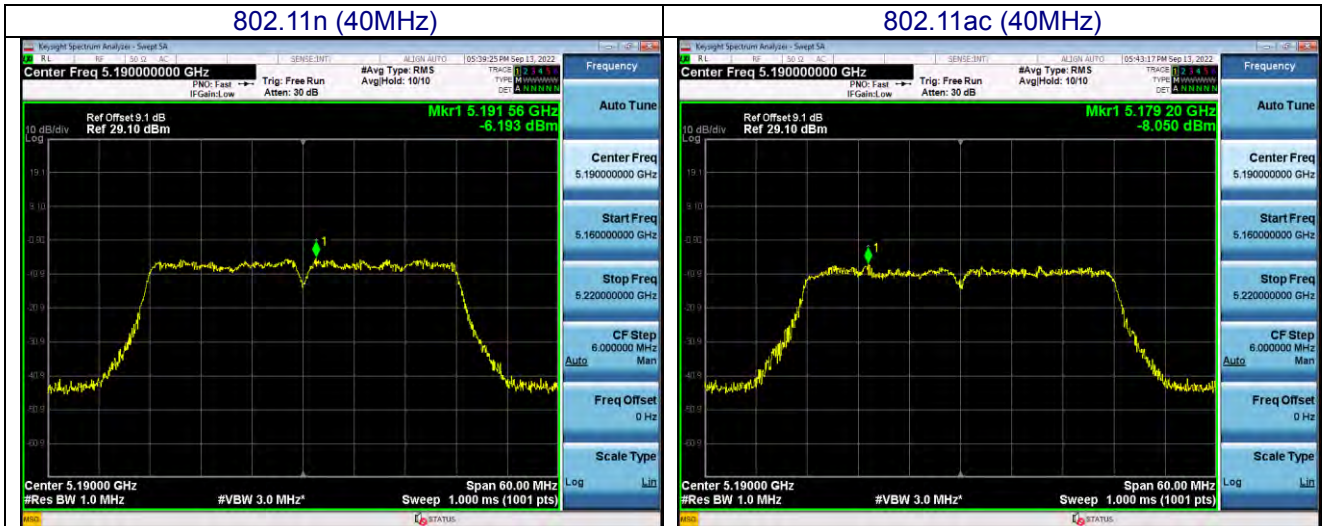

CH42 5210MHz

U-NII-3

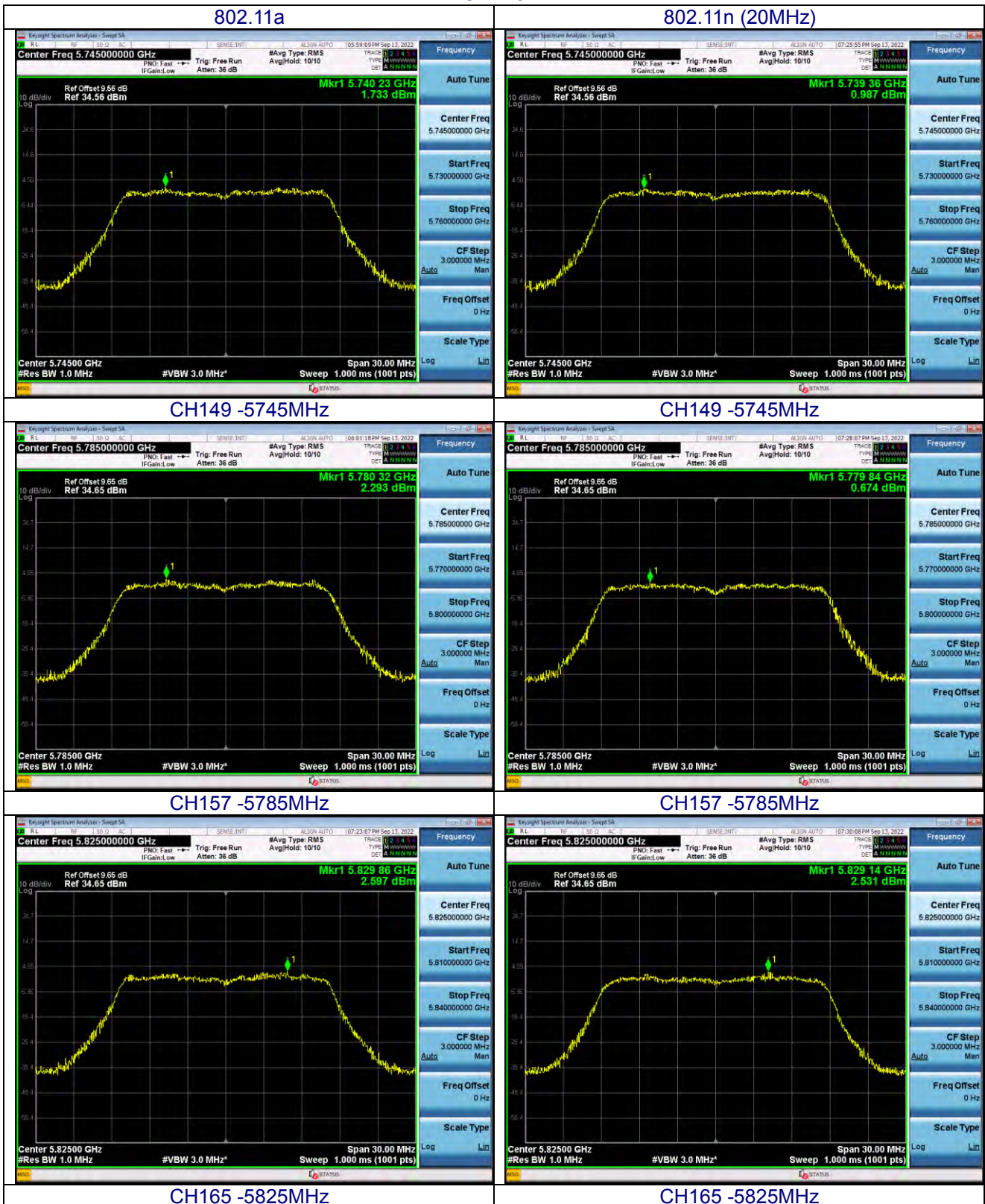

802.11ac (20MHz)



CH149 -5745MHz



CH157 -5785MHz



CH165 -5825MHz

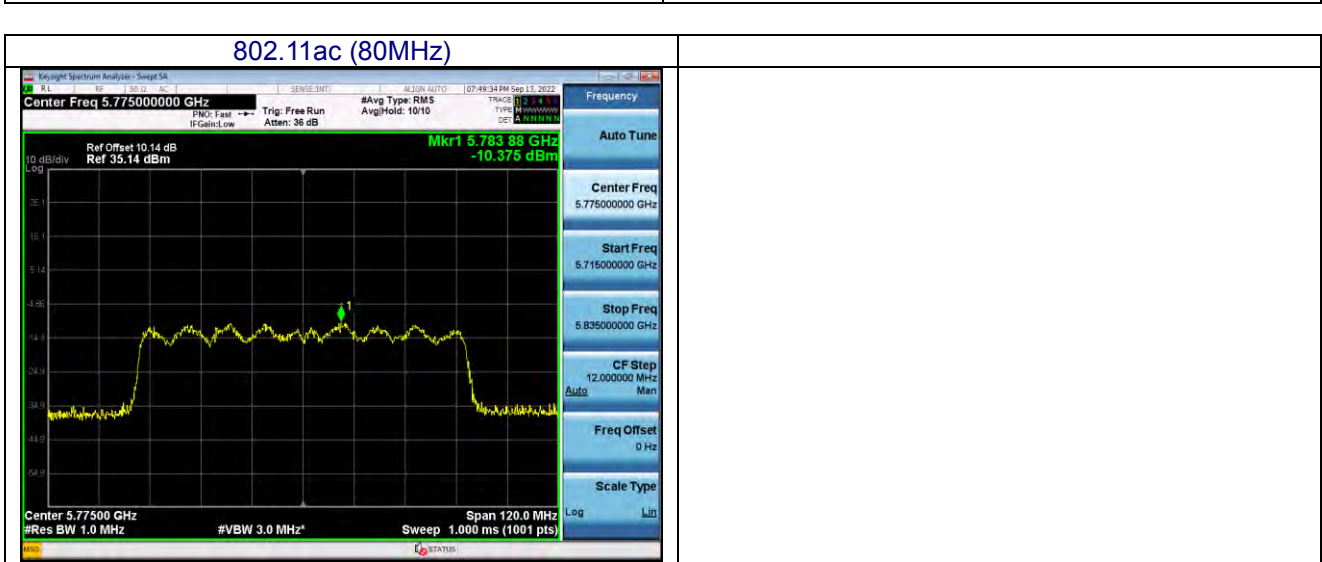
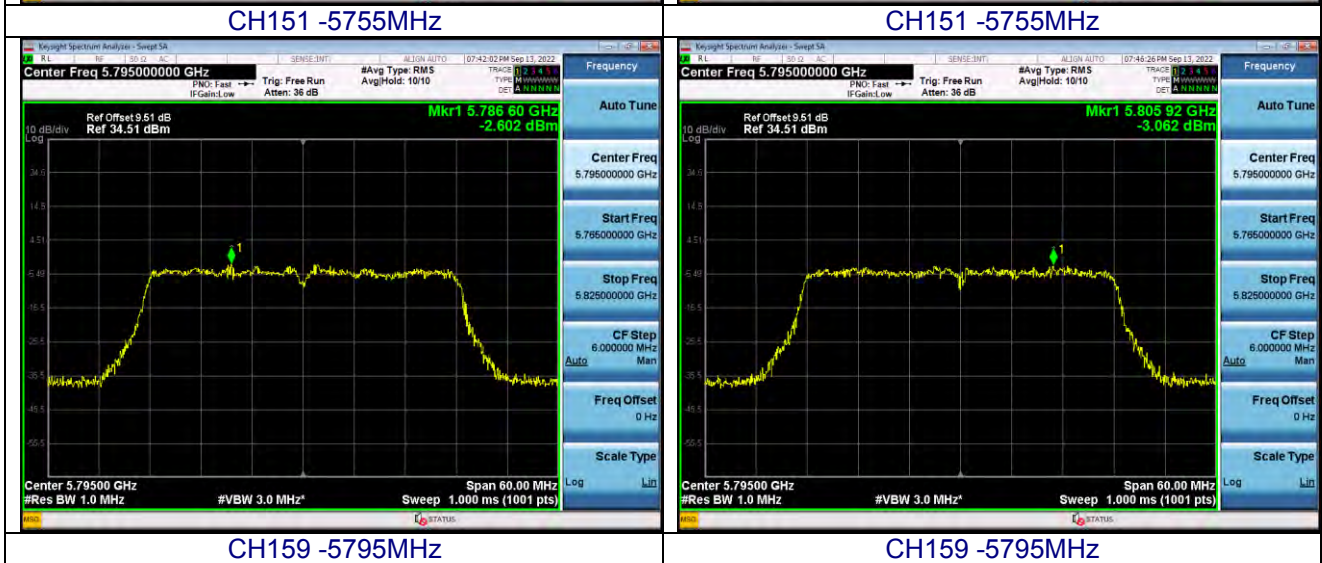
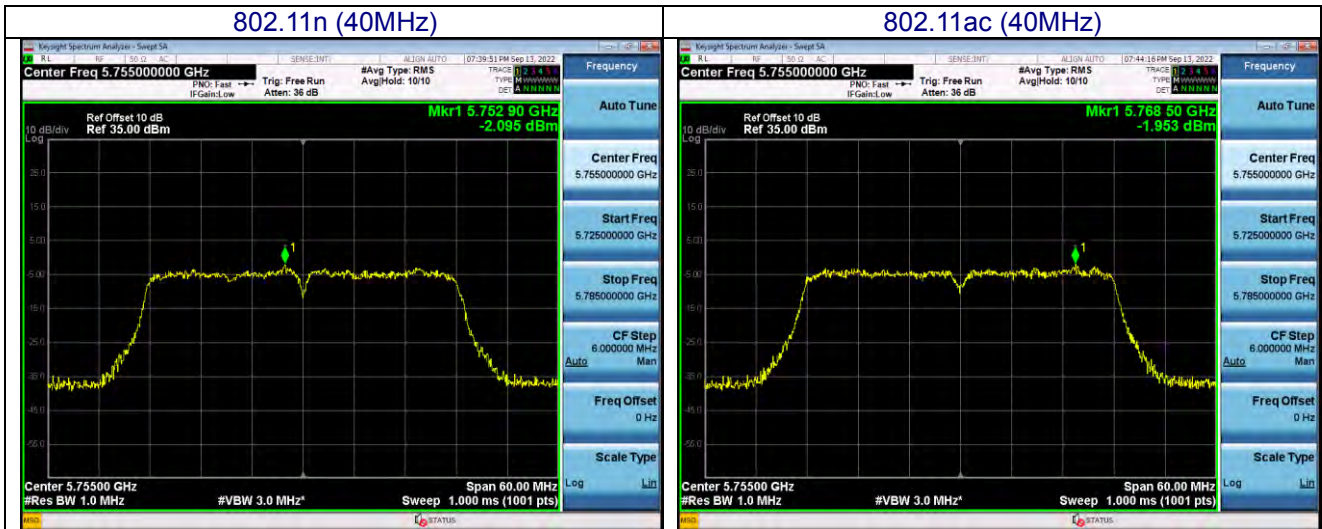

CH155 -5775MHz

6. -26 DB & 6DBM EMISSION BANDWIDTH

Test Requirement:	Part 15 Subpart C Section 15.407 (e)
Test Method:	KDB 789033 D02 v02r01

6.1 APPLIED PROCEDURES / LIMIT

FCC Part15.407 (e)		
Bandwidth		
Limit	U-NII-1	N/A
	U-NII-3	≥ 500 kHz

6.2 TEST PROCEDURE

Place the EUT on the table and set it in the transmitting mode.

Remove the antenna from the EUT and then connect a low-loss RF cable from the antenna port to the spectrum analyzer.

Set the spectrum analyzers RBW = approximately 1% of the emission bandwidth, VBW >RBW, Detector = Peak, Span>26dB bandwidth, and Sweep = auto ,Trace mode = max hold.

Measure the maximum width of the emission that is 26dB down from the maximum of the emission.

Compare this with the RBW setting of the analyzer. Readjust RBW and repeat measurement as needed until the RBW/EBW ratio is approximately 1%.

Repeat until all the rest channels were investigated.

6.3 DEVIATION FROM STANDARD

No deviation.

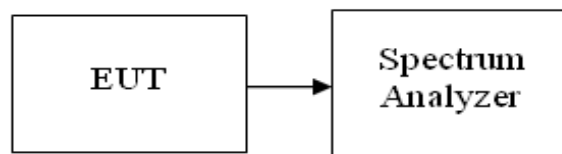
6.4 TEST SETUP**6.5 EUT OPERATION CONDITIONS**

The EUT tested system was configured as the statements of 2.4 Unless otherwise a special operating condition is specified in the follows during the testing.

6.6 TEST RESULT

Temperature :	26°C	Relative Humidity :	54%
Pressure :	101kPa	Test Voltage :	DC5.0V
Test Mode :	TX		

U-NII-1

802.11 Mode	Channel No.	Frequency [MHz]	26dB Bandwidth [MHz]	99% Bandwidth [MHz]
a	36	5180	19.42	16.442
	40	5200	19.48	16.448
	48	5240	19.05	16.435
n (20MHz)	36	5180	20.22	17.610
	40	5200	20.18	17.595
	48	5240	20.33	17.584
ac (20MHz)	36	5180	20.29	17.619
	40	5200	20.09	17.581
	48	5240	20.03	17.602
n(40MHz)	38	5190	42.97	36.442
	46	5230	52.48	36.510
ac(40MHz)	38	5190	71.19	36.564
	46	5230	65.63	36.501
ac(80MHz)	42	5210	82.29	75.647

U-NII-3

802.11 Mode	Channel No.	Frequency [MHz]	-6db Bandwidth [MHz]	Limit
a	149	5745	16.36	≥ 500 kHz
	157	5785	16.43	
	165	5825	16.33	
n (20MHz)	149	5745	17.31	
	157	5785	16.95	
	165	5825	17.52	
n (40MHz)	151	5755	17.08	
	159	5795	16.61	
ac (20MHz)	149	5745	17.29	
	157	5785	36.31	
	165	5825	36.19	
ac(40MHz)	151	5755	35.50	
	159	5795	36.07	
ac(80MHz)	155	5775	75.25	

Test plot as follows:

U-NII-1

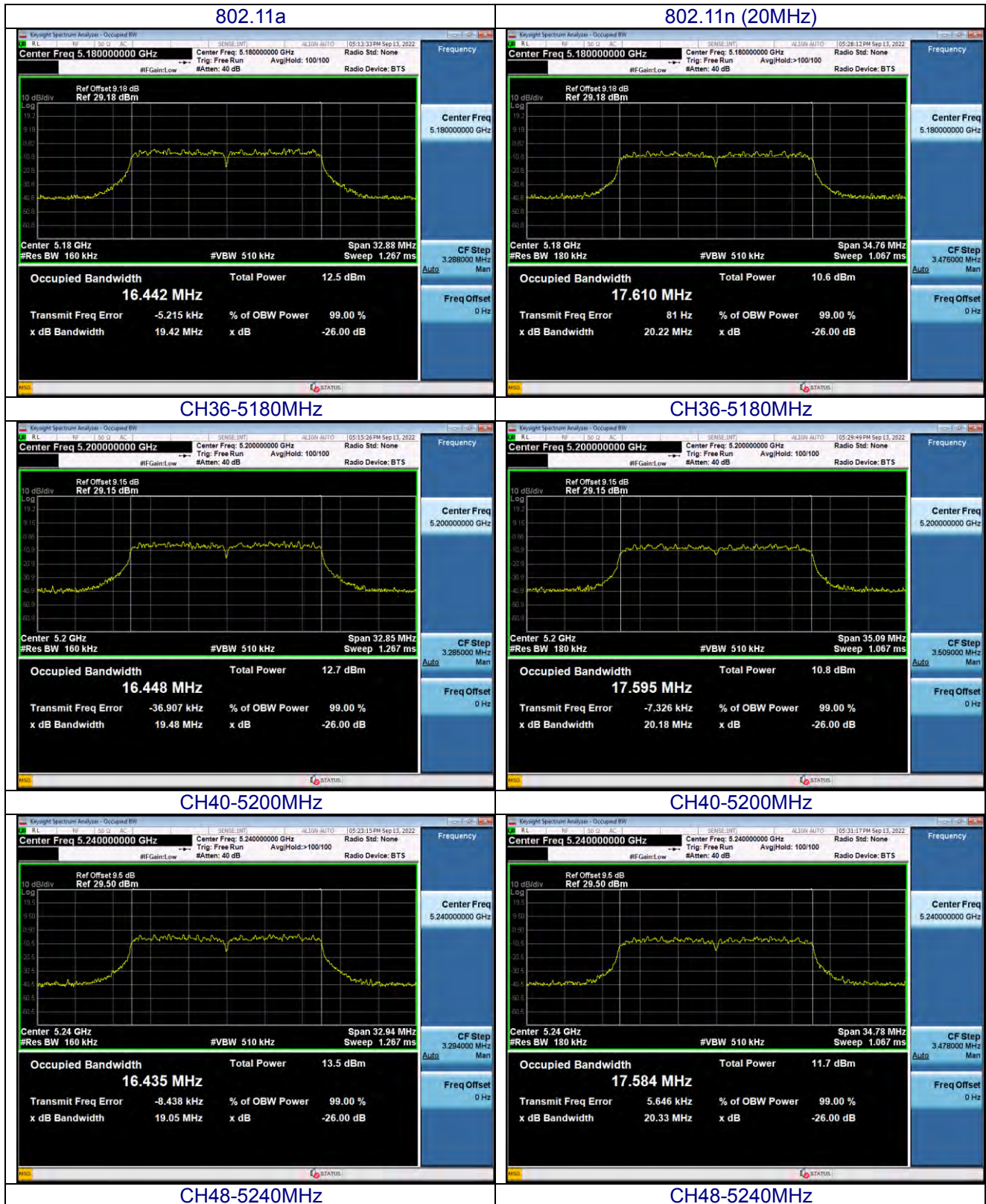

802.11ac 20MHz)

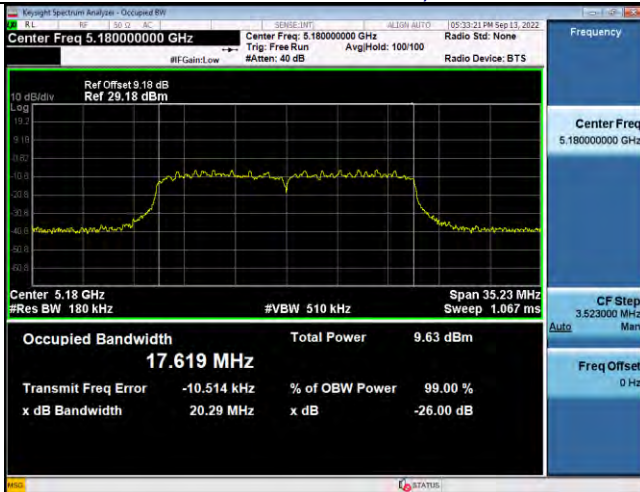

CH36-5180MHz

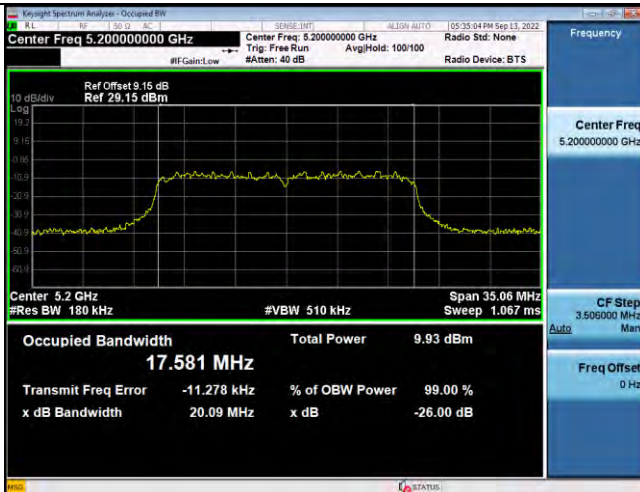

CH40-5200MHz

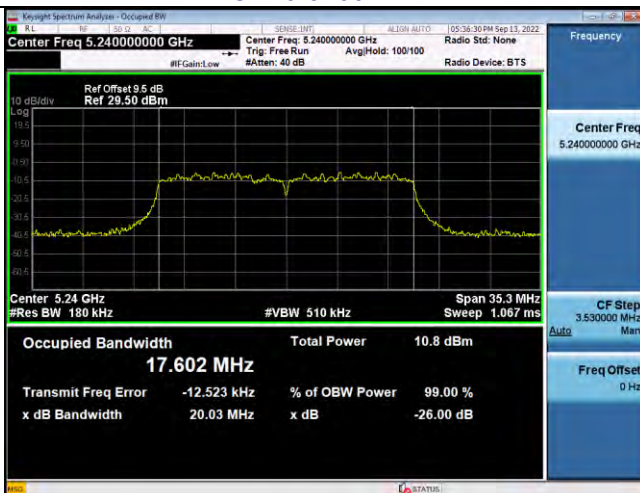

CH48-5240MHz

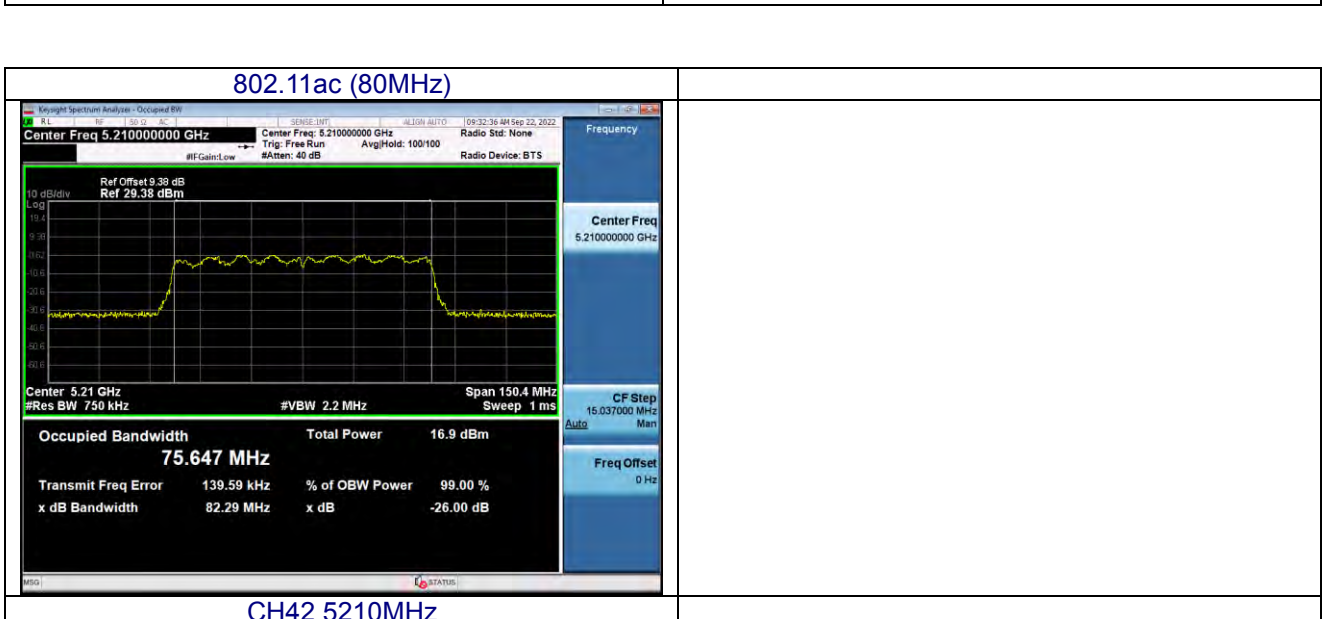
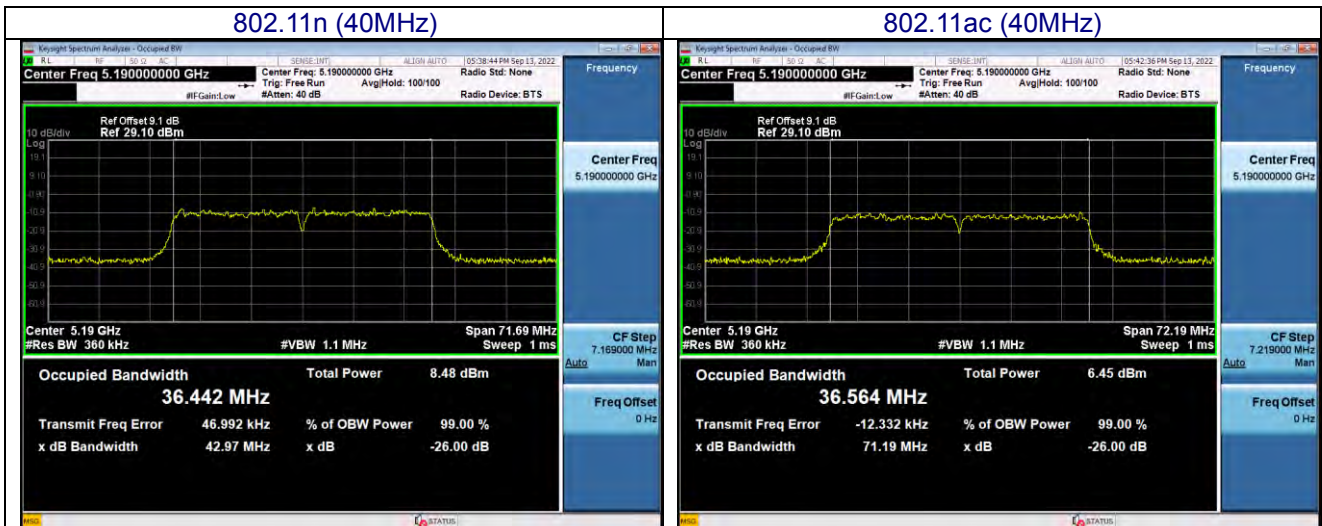

CH42 5210MHz

U-NII-3

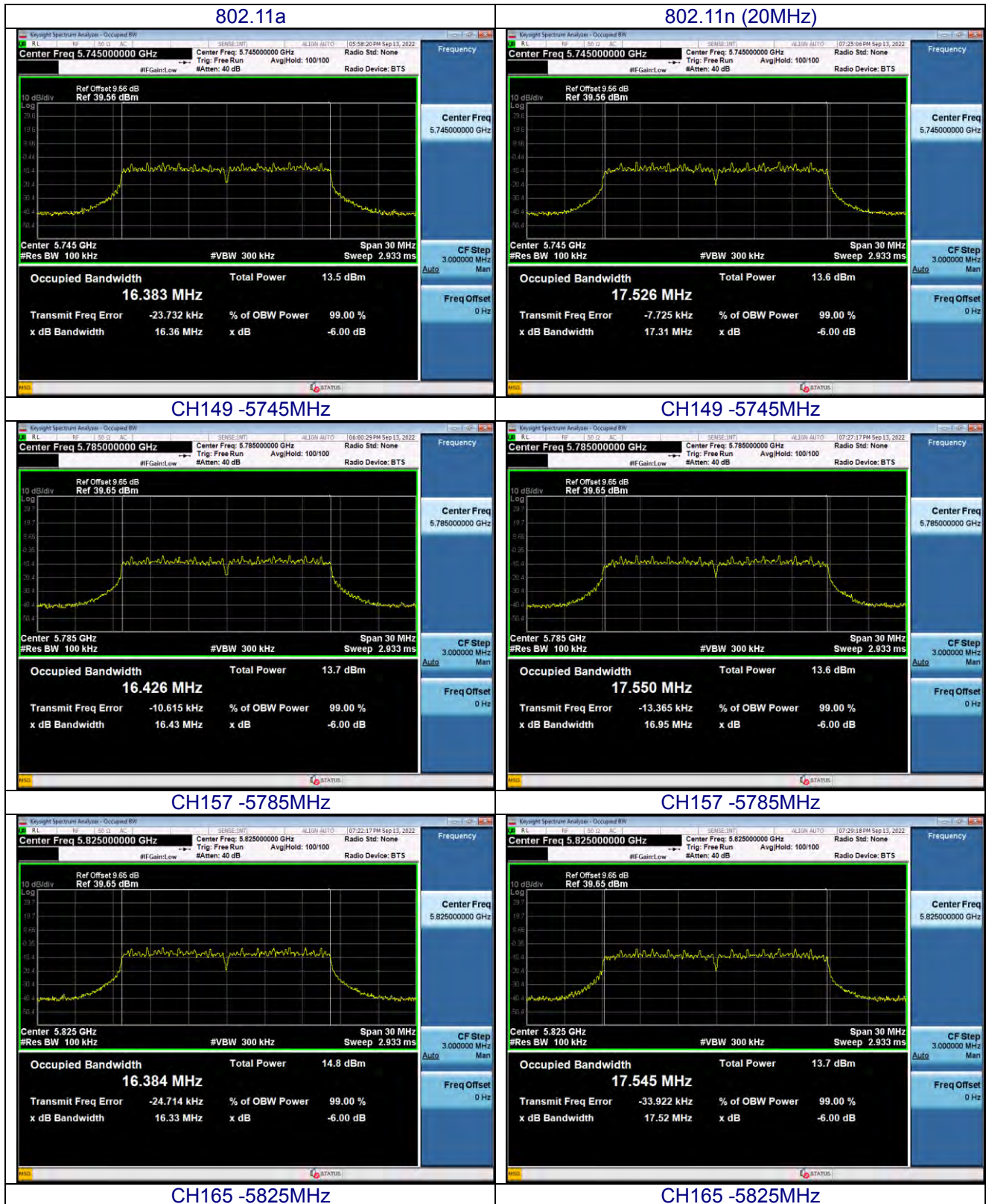

802.11ac (20MHz)

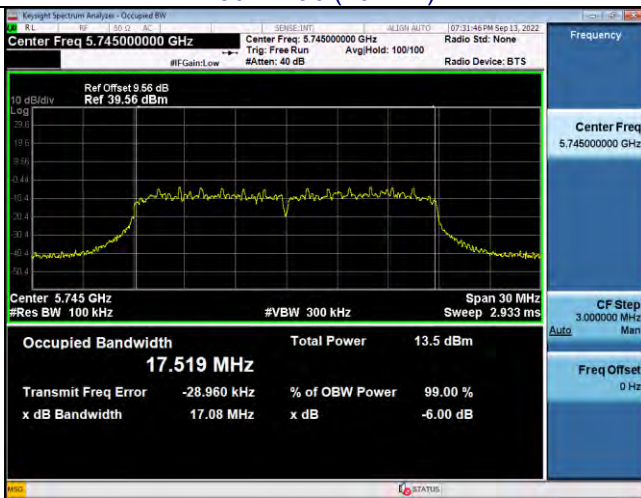

CH149 -5745MHz

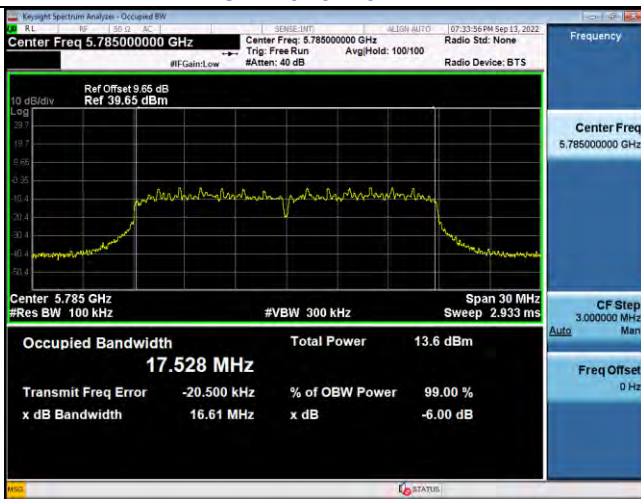

CH157 -5785MHz

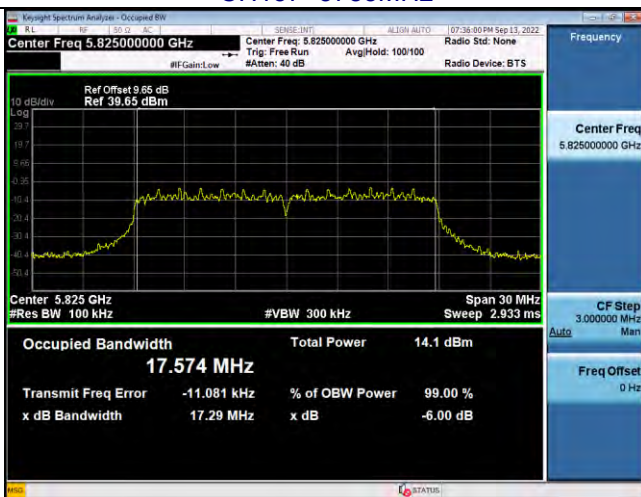

CH165 -5825MHz

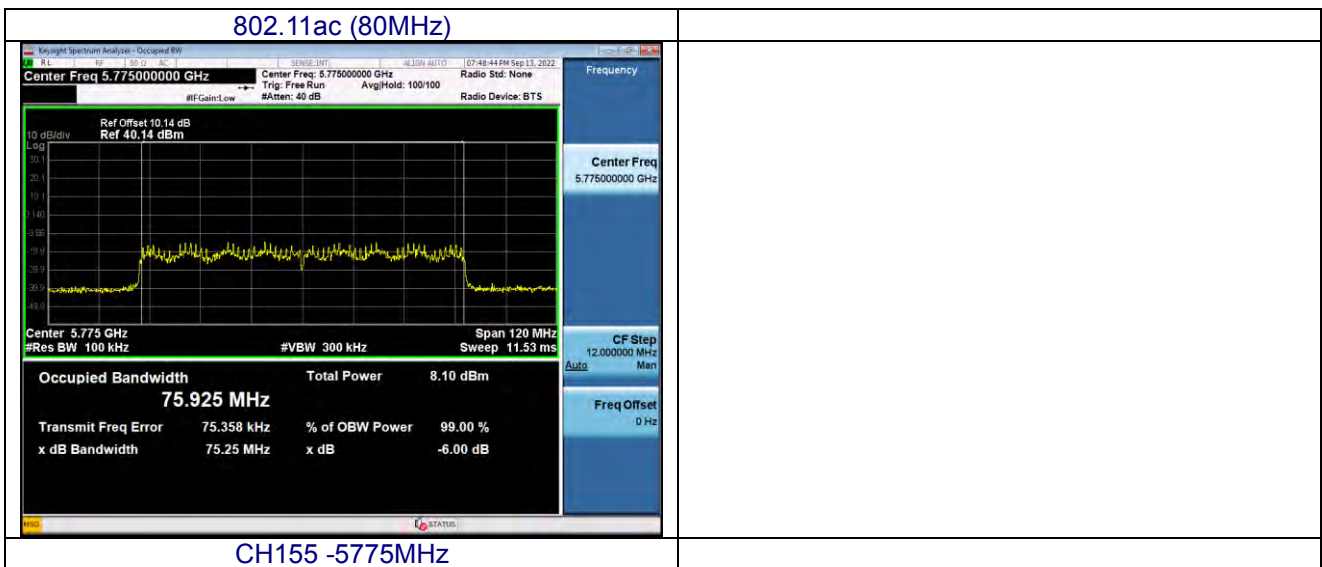
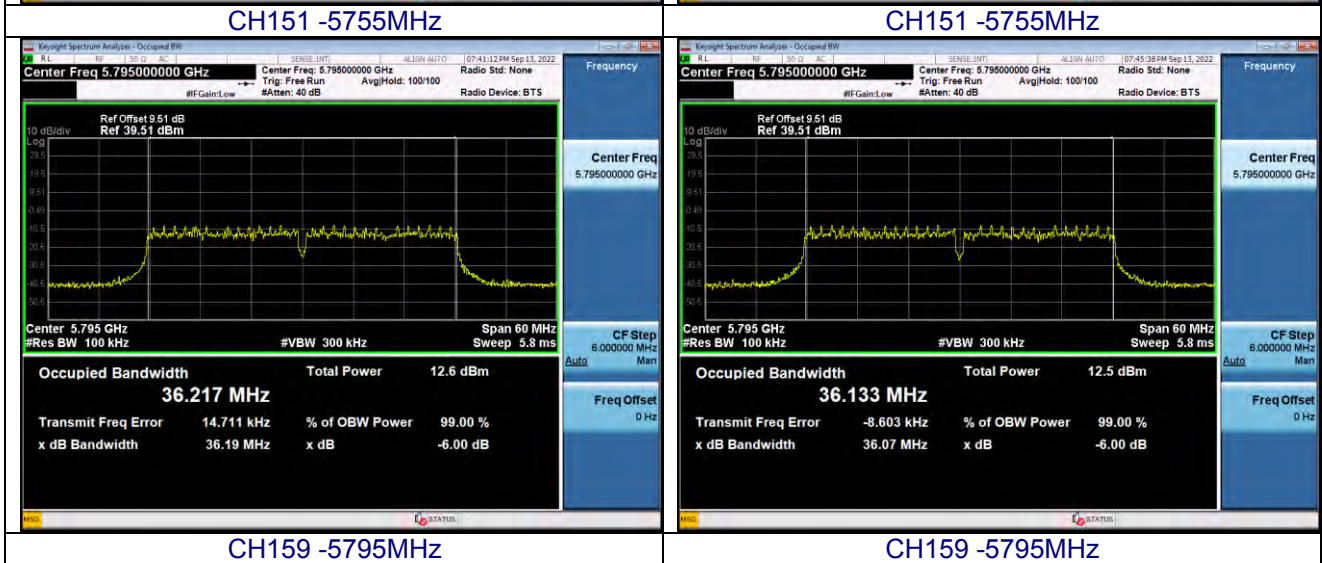
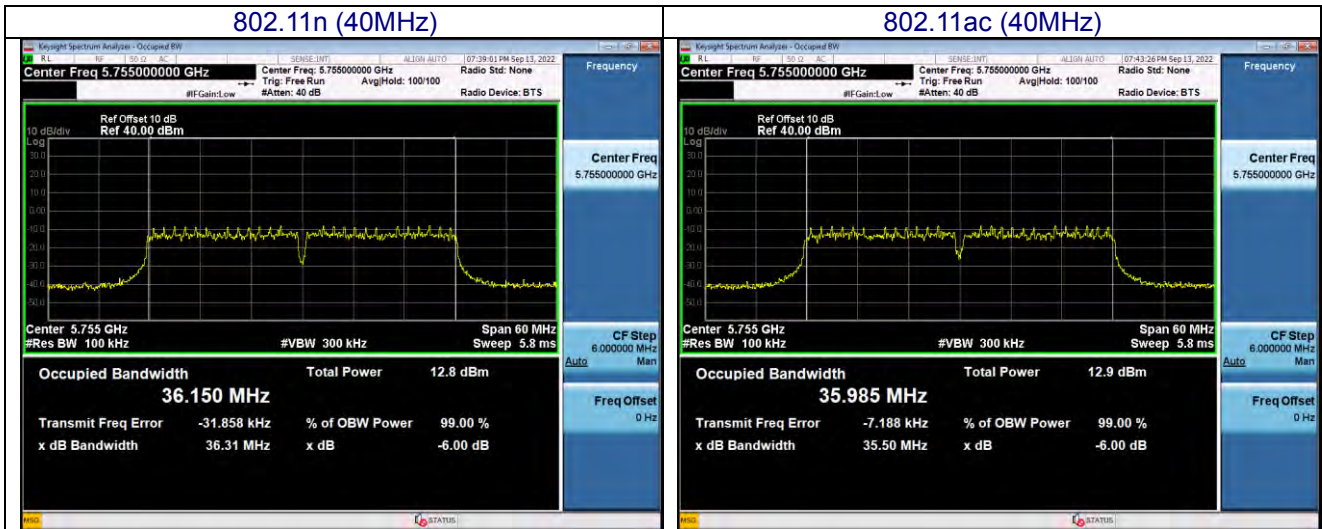

CH155 -5775MHz

7. OUTPUT POWER TEST

Test Requirement:	15.407 (a)(1)(2)(3)
Test Method:	KDB 789033 D02 v02r01

7.1 APPLIED PROCEDURES/LIMIT

For client devices in the 5.15-5.25 GHz band, the maximum conducted output power over the frequency band of operation shall not exceed 250 mW provided the maximum antenna gain does not exceed 6 dBi. In addition, the maximum power spectral density shall not exceed 11 dBm in any 1 megahertz band. If transmitting antennas of directional gain greater than 6 dBi are used, both the maximum conducted output power and the maximum power spectral density shall be reduced by the amount in dB that the directional gain of the antenna exceeds 6 dBi.

For the band 5.725-5.850 GHz, the maximum conducted output power over the frequency band of operation shall not exceed 1 W. In addition, the maximum power spectral density shall not exceed 30 dBm in any 500-kHz band. If transmitting antennas of directional gain greater than 6 dBi are used, both the maximum conducted output power and the maximum power spectral density shall be reduced by the amount in dB that the directional gain of the antenna exceeds 6 dBi.

Test Item	Band	Limit	Result
Max conducted output power	U-NII-1	0.25W / 23.98dbm	Pass
Max conducted output power	U-NII-3	1 W / 30dbm	Pass

7.2 DEVIATION FROM STANDARD

No deviation.

7.3 TEST SETUP

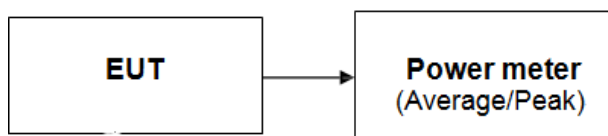

7.4 EUT OPERATION CONDITIONS

The EUT tested system was configured as the statements of 2.4 Unless otherwise a special operating condition is specified in the follows during the testing.

7.5 TEST RESULT

Temperature :	26°C	Relative Humidity :	54%
Pressure :	101kPa	Test Voltage :	DC5.0V

U-NII-1

802.11 Mode	Channel No.	Frequency [MHz]	Conducted Power [dBm]	Limit [dBm]
a	36	5180	10.98	23.98
	40	5200	11.28	23.98
	48	5240	11.91	23.98
n(20MHz)	36	5180	9.16	23.98
	40	5200	9.41	23.98
	48	5240	10.38	23.98
ac(20MHz)	36	5180	8.23	23.98
	40	5200	8.47	23.98
	48	5240	9.33	23.98
n(40MHz)	38	5190	7.25	23.98
	46	5230	6.99	23.98
ac(40MHz)	38	5190	5.22	23.98
	46	5230	5.92	23.98
ac(80MHz)	42	5210	1.83	23.98

U-NII-3

802.11 Mode	Channel No.	Frequency [MHz]	Conducted Power [dBm]	Limit [dBm]
a	149	5745	12.04	30.00
	157	5785	12.26	30.00
	165	5825	12.90	30.00
n (20MHz)	149	5745	11.93	30.00
	157	5785	12.05	30.00
	165	5825	12.21	30.00
n (40MHz)	151	5755	12.09	30.00
	159	5795	12.33	30.00
ac (20MHz)	149	5745	12.58	30.00
	157	5785	10.82	30.00
	165	5825	10.73	30.00
ac(40MHz)	151	5755	11.05	30.00
	159	5795	10.78	30.00
ac(80MHz)	155	5775	5.56	30.00

8. OUT OF BAND EDGE EMISSION

Test Requirement:	15.407 (b)
Test Method:	KDB 789033 D02 v02r01

8.1 TEST PROCEDURE

1. Check the calibration of the measuring instrument using either an internal calibrator or a known signal from an external generator.
2. Position the EUT without connection to measurement instrument. Turn on the EUT and connect its antenna terminal to measurement instrument via a low loss cable. Then set it to any one measured frequency within its operating range, and make sure the instrument is operated in its linear range.
3. Set RBW of spectrum analyzer to 1 MHz with a convenient frequency span.
4. Measure the highest amplitude appearing on spectral display and set it as a reference level. Plot the graph with marking the highest point and edge frequency.
5. Repeat above procedures until all measured frequencies were complete.

8.2 DEVIATION FROM STANDARD

No deviation.

8.3 TEST SETUP

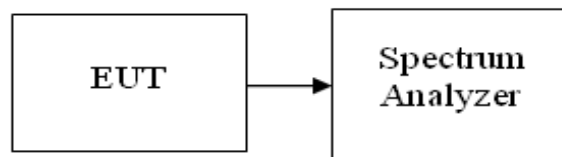

8.4 EUT OPERATION CONDITIONS

The EUT tested system was configured as the statements of 2.4 Unless otherwise a special operating condition is specified in the follows during the testing.

8.5 TEST RESULTS

Test plot as follows:

U-NII-1

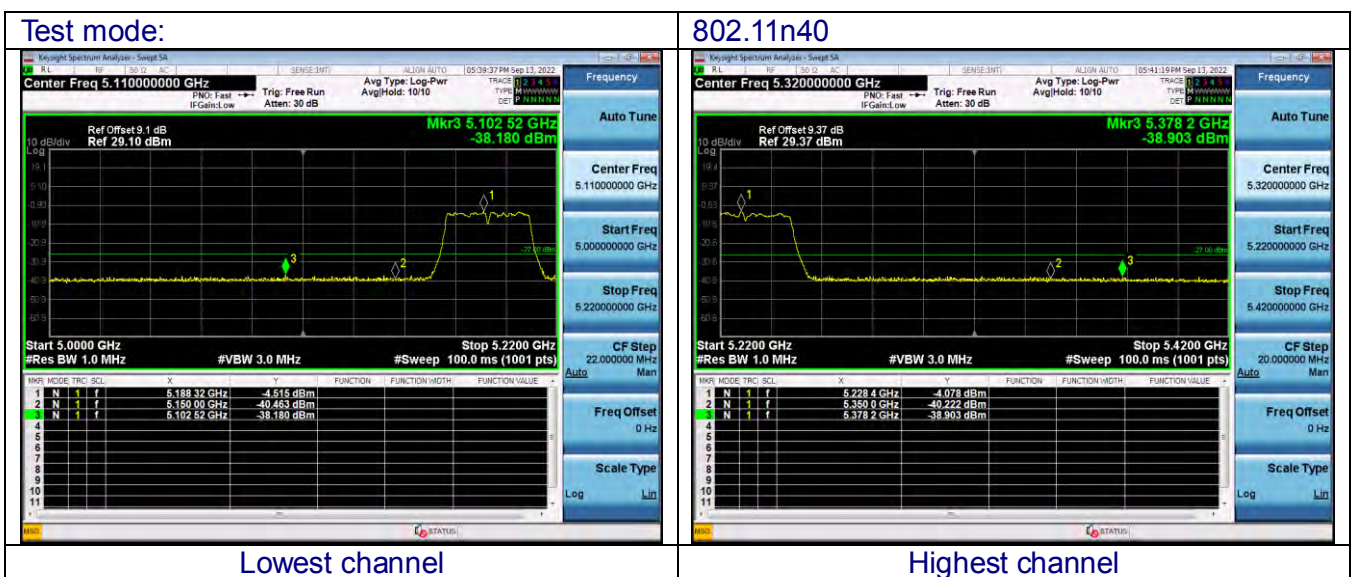
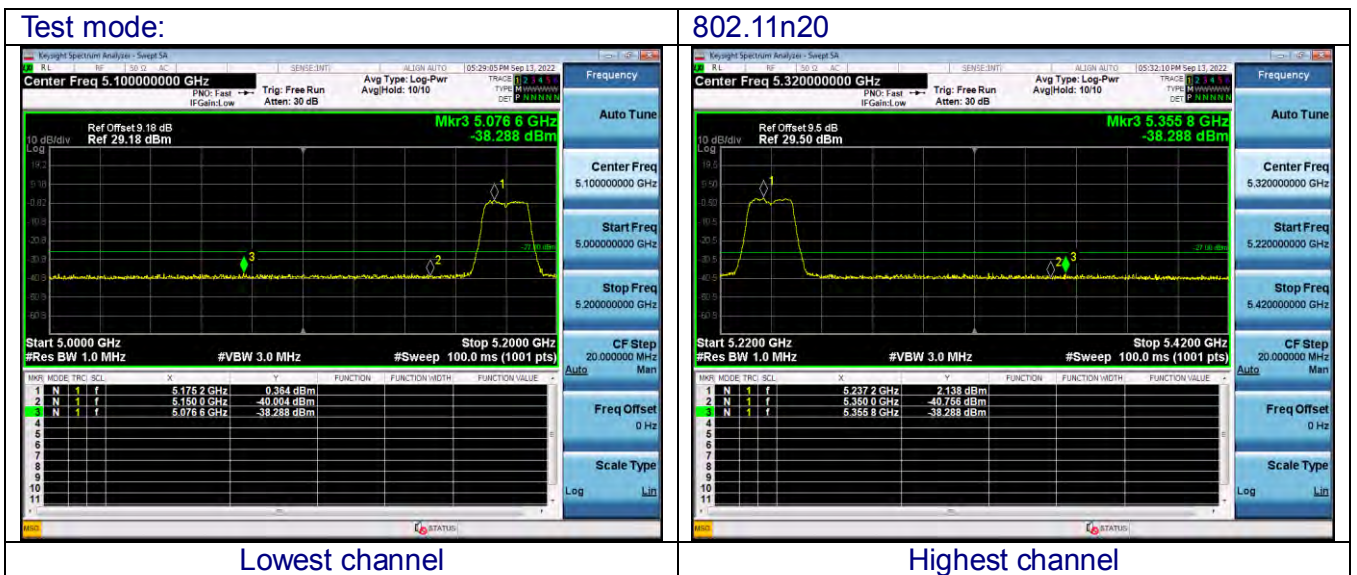
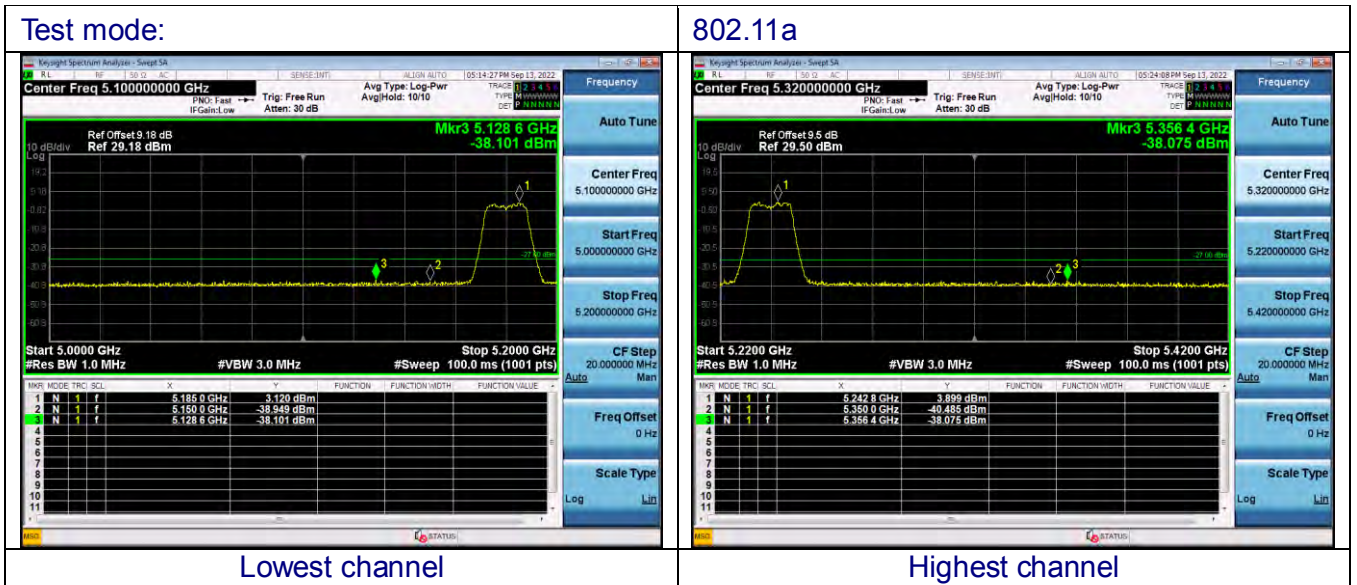

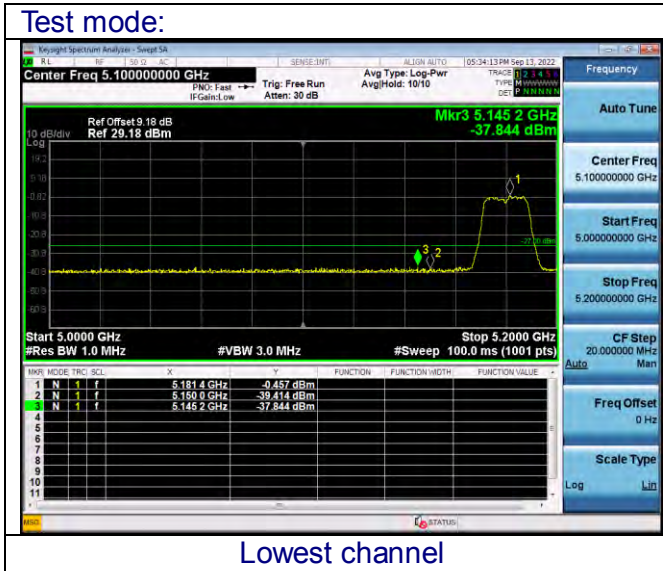

Lowest channel

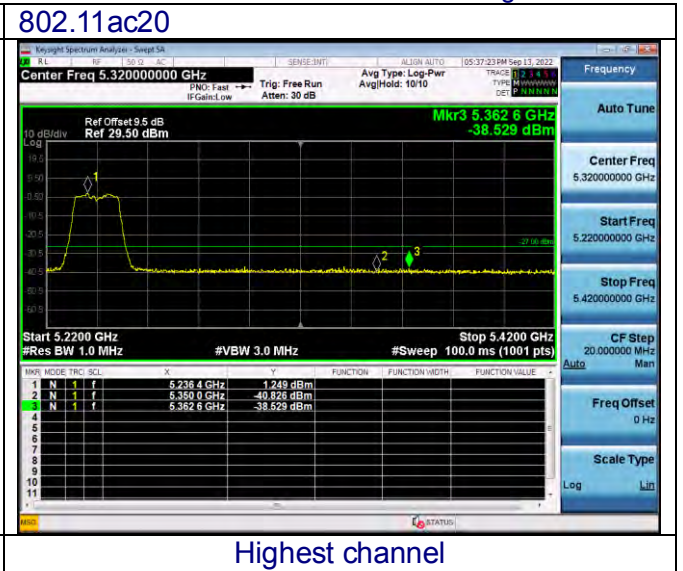

Highest channel

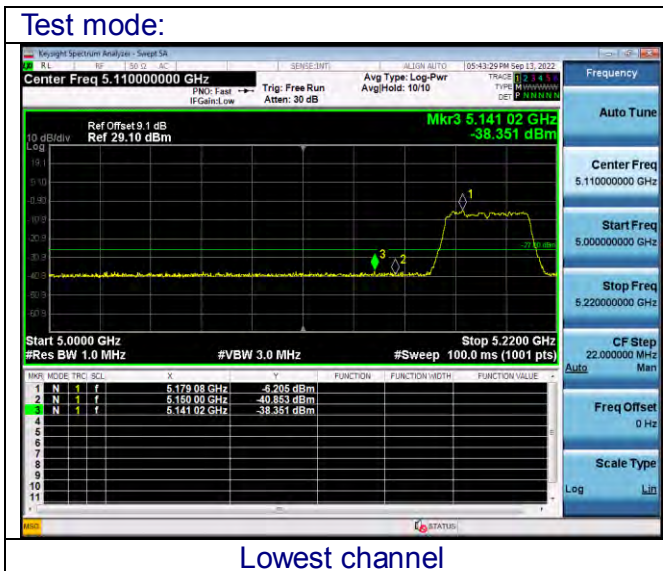

Lowest channel

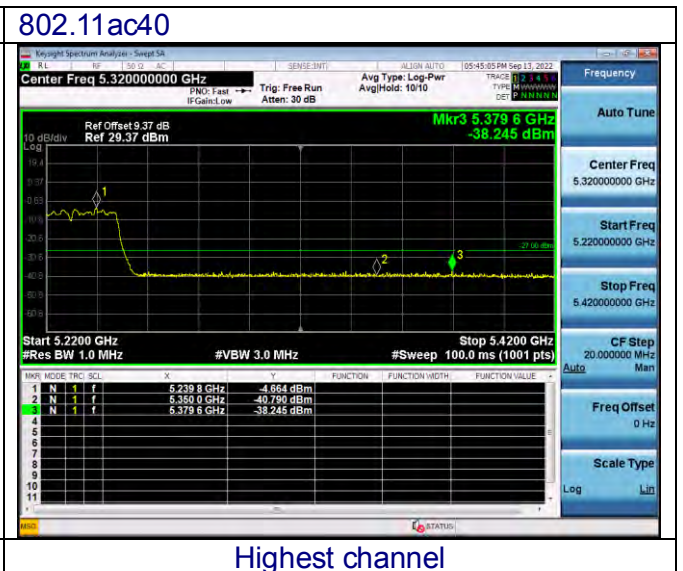

Highest channel

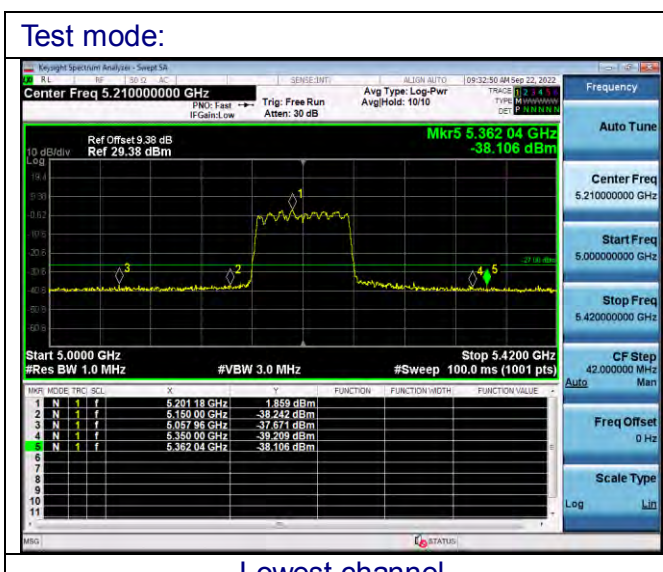

Lowest channel

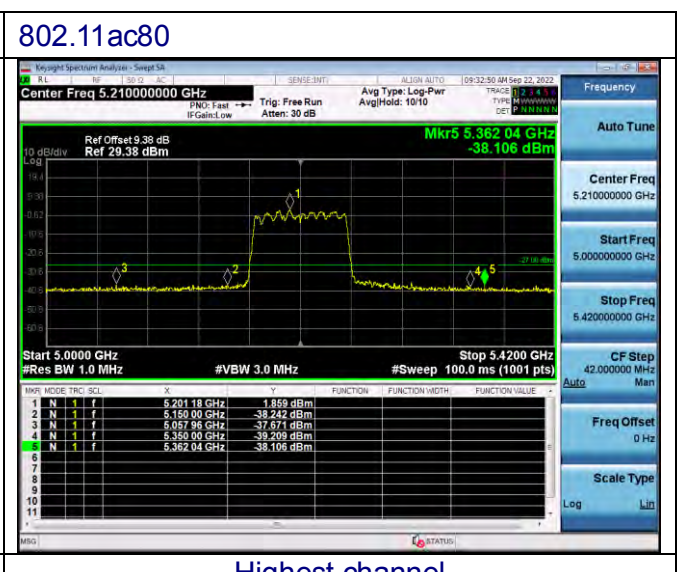

Highest channel

U-NII-3

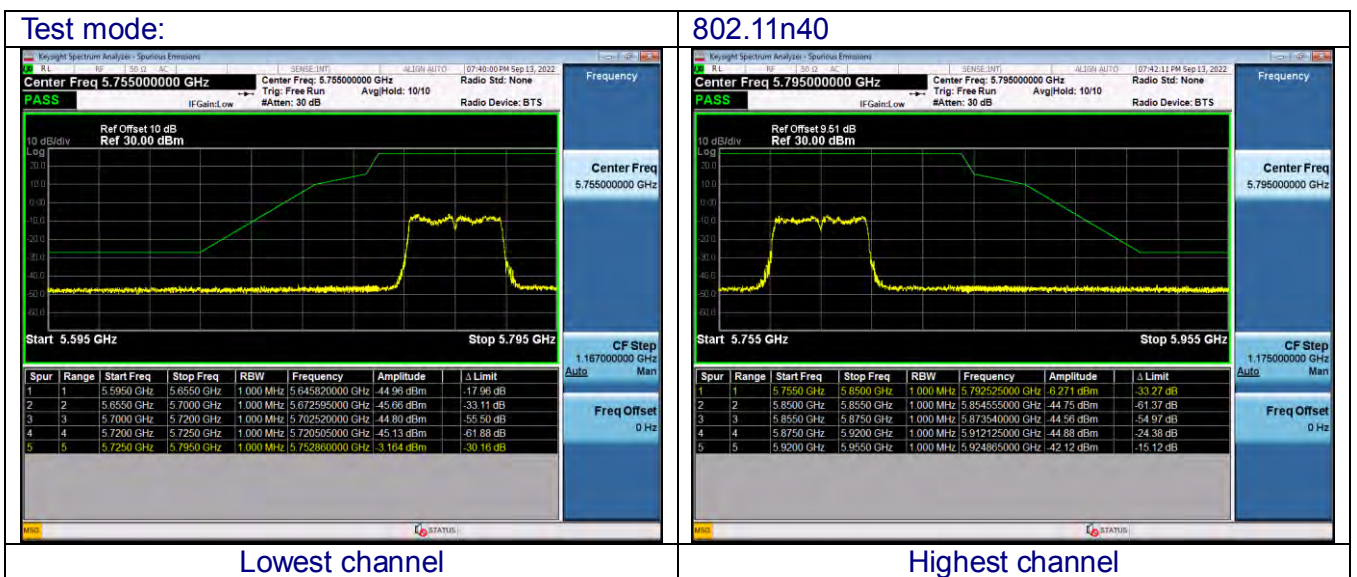
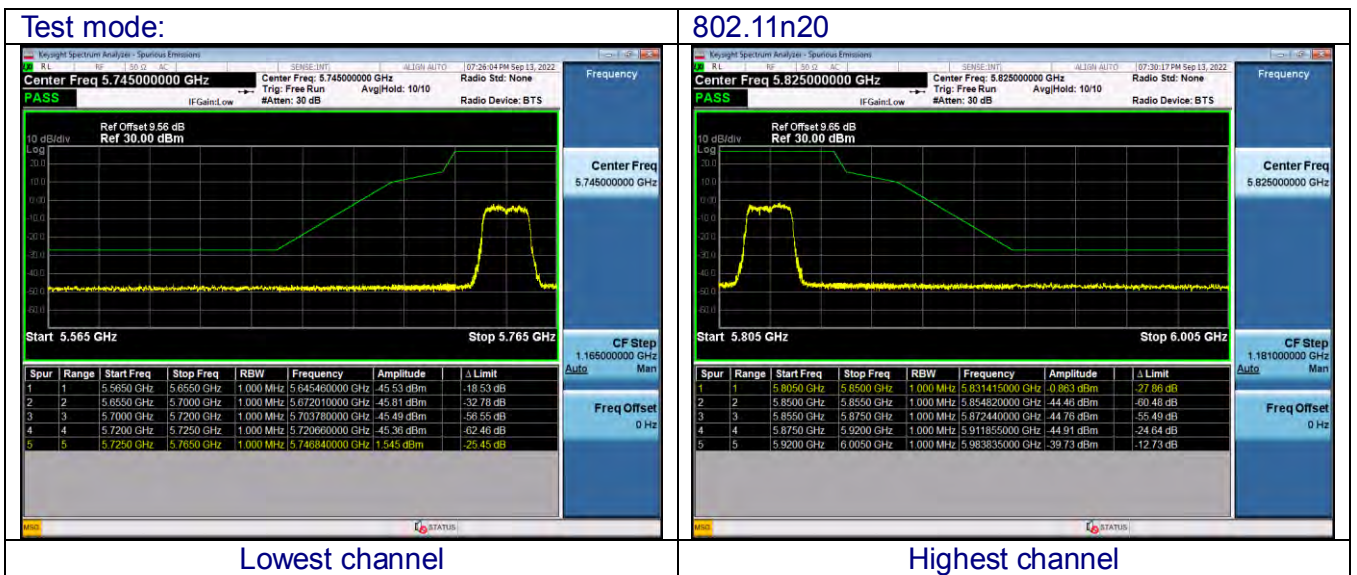
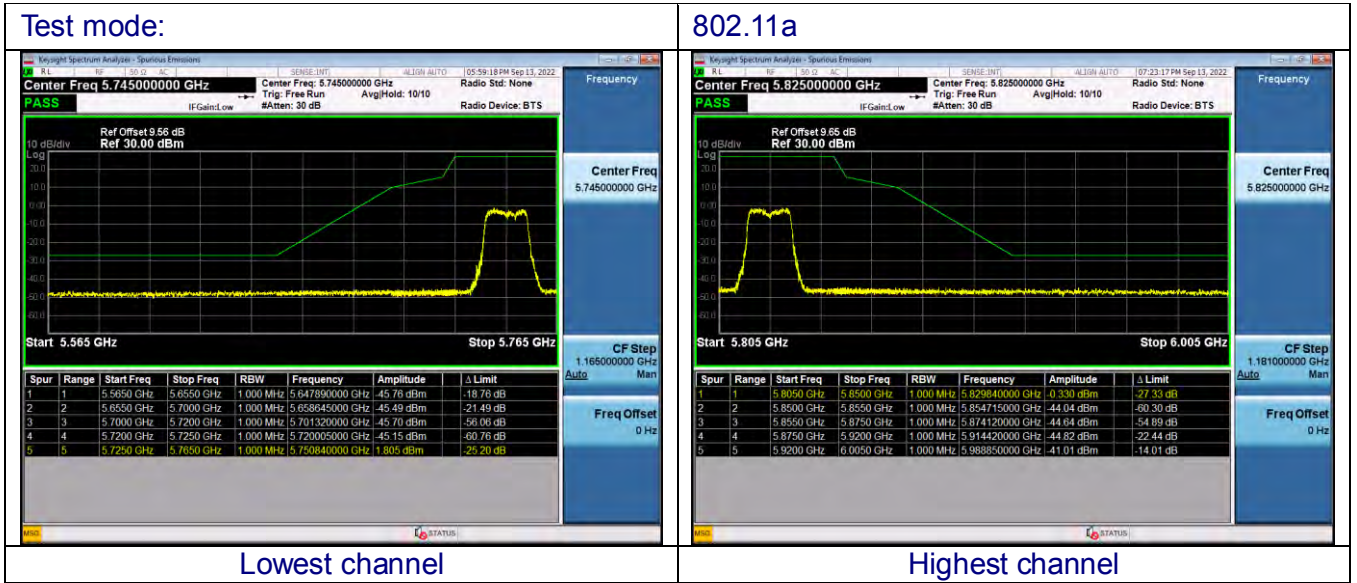

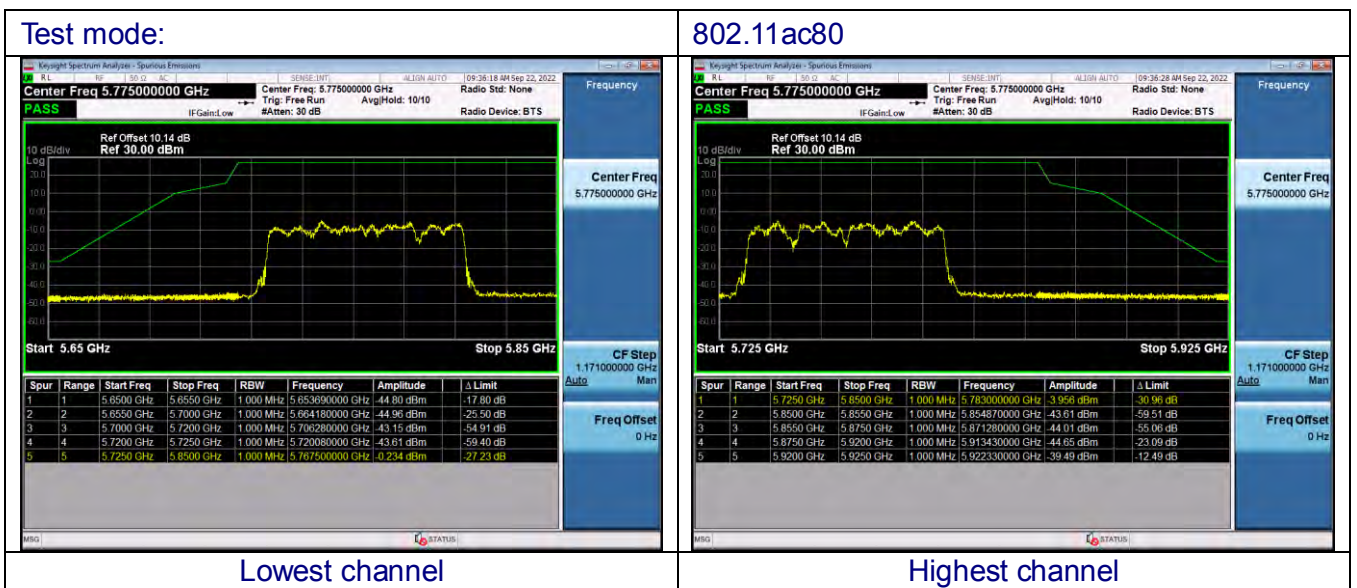
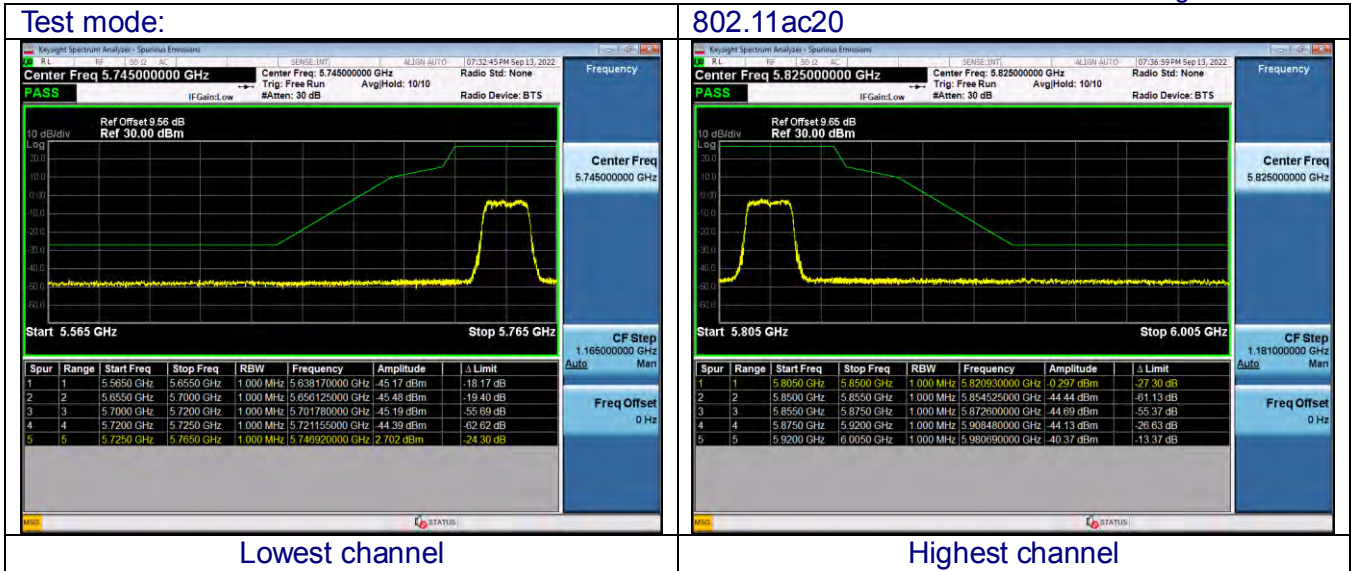

9. FREQUENCY STABILITY MEASUREMENT

9.1 LIMIT

According to §15.407(g), Manufacturers of U-NII devices are responsible for ensuring frequency stability such that an emission is maintained within the band of operation under all conditions of normal operation as specified in the user's manual.

9.2 TEST PROCEDURE

1. To ensure emission at the band edge is maintained within the authorized band, those values shall be measured by radiation emissions at upper and lower frequency points, and finally compensated by frequency deviation as procedures below.
2. The EUT was operated at the maximum output power, and connected to the spectrum analyzer, which is set to maximum hold function and peak detector. The peak value of the power envelope was measured and noted. The upper and lower frequency points were respectively measured relatively 10dB lower than the measured peak value.
3. The frequency deviation was calculated by adding the upper frequency point and the lower frequency point divided by two. Those detailed values of frequency deviation are provided in table below.

9.3 TEST CONFIGURATION

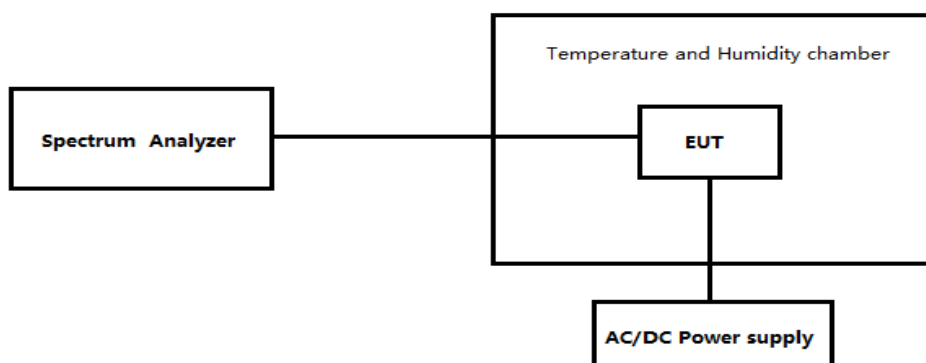

9.4 TEST RESULT

Temperature :	26°C	Relative Humidity :	54%
Pressure :	101kPa	Test Voltage :	DC5.0V

Note: Only the test results of the worst channel are displayed

ANT1-802.11a- CH36

Temperature (°C)	Voltage (DC:V)	Frequency Measure with time Elapsed	
		MCF	(ppm)
50	5.0	0.004	0.683
40	5.0	0.016	3.163
30	5.0	0.008	1.607
20	5.0	0.016	3.074
10	5.0	0.002	0.290
0	5.0	0.011	2.082
-10	5.0	0.008	1.607
-20	5.0	0.010	1.922
-30	5.0	0.013	2.566

ANT1-802.11a-CH48

Temperature (°C)	Voltage (DC:V)	Frequency Measure with time Elapsed	
		MCF	(ppm)
50	5.0	0.015	2.865
40	5.0	0.002	0.338
30	5.0	0.015	2.865
20	5.0	0.012	2.366
10	5.0	0.011	2.023
0	5.0	0.011	2.023
-10	5.0	0.014	2.709
-20	5.0	0.016	3.066
-30	5.0	0.002	0.338

ANT1-802.11a-CH149

Temperature (°C)	Voltage (DC:V)	Frequency Measure with time Elapsed	
		MCF	(ppm)
50	5.0	0.017	2.973
40	5.0	0.002	0.393
30	5.0	0.003	0.447
20	5.0	0.012	2.135
10	5.0	0.003	0.447
0	5.0	0.013	2.255
-10	5.0	0.016	2.841
-20	5.0	0.006	1.054
-30	5.0	0.014	2.437

ANT1-802.11a-CH165

Temperature (°C)	Voltage (DC:V)	Frequency Measure with time Elapsed	
		MCF	(ppm)
50	5.0	0.012	2.050
40	5.0	0.017	2.854

30	5.0	0.002	0.349
20	5.0	0.008	1.331
10	5.0	0.002	0.349
0	5.0	0.013	2.211
-10	5.0	0.016	2.831
-20	5.0	0.001	0.221
-30	5.0	0.014	2.339

ANT1-802.11n20-CH36

Temperature (°C)	Voltage (DC:V)	Frequency Measure with time Elapsed	
		MCF	(ppm)
50	5.0	0.010	2.001
40	5.0	0.004	0.803
30	5.0	0.006	1.251
20	5.0	0.017	3.239
10	5.0	0.010	2.001
0	5.0	0.011	2.087
-10	5.0	0.017	3.239
-20	5.0	0.007	1.414
-30	5.0	0.001	0.223

ANT1-802.11n20-CH48

Temperature (°C)	Voltage (DC:V)	Frequency Measure with time Elapsed	
		MCF	(ppm)
50	5.0	0.011	2.015
40	5.0	0.013	2.465
30	5.0	0.016	3.000
20	5.0	0.010	1.917
10	5.0	0.015	2.948
0	5.0	0.001	0.279
-10	5.0	0.006	1.085
-20	5.0	0.006	1.085
-30	5.0	0.010	1.882

ANT1-802.11n20-CH149

Temperature (°C)	Voltage (DC:V)	Frequency Measure with time Elapsed	
		MCF	(ppm)
50	5.0	0.017	2.991
40	5.0	0.001	0.189
30	5.0	0.006	0.981
20	5.0	0.006	1.131
10	5.0	0.015	2.635
0	5.0	0.012	2.040
-10	5.0	0.011	1.880
-20	5.0	0.003	0.454

-30	5.0	0.005	0.889
-----	-----	-------	-------

ANT1-802.11n20-CH165

Temperature (°C)	Voltage (DC:V)	Frequency Measure with time Elapsed	
		MCF	(ppm)
50	5.0	0.016	2.682
40	5.0	0.012	2.028
30	5.0	0.011	1.962
20	5.0	0.007	1.133
10	5.0	0.016	2.825
0	5.0	0.011	1.962
-10	5.0	0.011	1.962
-20	5.0	0.007	1.137
-30	5.0	0.002	0.387

ANT1-802.11n40-CH38

Temperature (°C)	Voltage (DC:V)	Frequency Measure with time Elapsed	
		MCF	(ppm)
50	5.0	0.009	1.760
40	5.0	0.003	0.660
30	5.0	0.009	1.760
20	5.0	0.015	2.933
10	5.0	0.005	0.880
0	5.0	0.012	2.313
-10	5.0	0.005	0.880
-20	5.0	0.013	2.571
-30	5.0	0.002	0.415

ANT1-802.11n40-CH46

Temperature (°C)	Voltage (DC:V)	Frequency Measure with time Elapsed	
		MCF	(ppm)
50	5.0	0.015	2.864
40	5.0	0.007	1.410
30	5.0	0.016	3.032
20	5.0	0.007	1.373
10	5.0	0.013	2.511
0	5.0	0.017	3.350
-10	5.0	0.003	0.518
-20	5.0	0.006	1.125
-30	5.0	0.013	2.511

ANT1-802.11n40-CH151

Temperature (°C)	Voltage (DC:V)	Frequency Measure with time Elapsed	
		MCF	(ppm)
50	5.0	0.007	1.218
40	5.0	0.012	2.120
30	5.0	0.004	0.624
20	5.0	0.002	0.431
10	5.0	0.017	2.969
0	5.0	0.001	0.211
-10	5.0	0.011	1.990
-20	5.0	0.002	0.431
-30	5.0	0.012	2.120

ANT1-802.11n40-CH159

Temperature (°C)	Voltage (DC:V)	Frequency Measure with time Elapsed	
		MCF	(ppm)
50	5.0	0.012	2.091
40	5.0	0.005	0.785
30	5.0	0.010	1.809
20	5.0	0.005	0.785
10	5.0	0.014	2.414
0	5.0	0.002	0.351
-10	5.0	0.017	2.910
-20	5.0	0.008	1.368
-30	5.0	0.011	1.827

ANT1-802.11ac20-CH36

Temperature (°C)	Voltage (DC:V)	Frequency Measure with time Elapsed	
		MCF	(ppm)
50	5.0	0.010	2.024
40	5.0	0.012	2.232
30	5.0	0.012	2.232
20	5.0	0.008	1.502
10	5.0	0.011	2.112
0	5.0	0.010	1.937
-10	5.0	0.011	2.112
-20	5.0	0.004	0.736
-30	5.0	0.005	0.963

ANT1-802.11ac20-CH48

Temperature (°C)	Voltage (DC:V)	Frequency Measure with time Elapsed	
		MCF	(ppm)
50	5.0	0.012	2.363
40	5.0	0.001	0.144
30	5.0	0.003	0.597

20	5.0	0.015	2.878
10	5.0	0.004	0.702
0	5.0	0.008	1.572
-10	5.0	0.016	3.051
-20	5.0	0.012	2.331
-30	120	0.005	0.950

ANT1-802.11ac20-CH149

Temperature (°C)	Voltage (DC:V)	Frequency Measure with time Elapsed	
		MCF	(ppm)
50	5.0	0.007	1.282
40	5.0	0.005	0.830
30	5.0	0.010	1.657
20	5.0	0.016	2.826
10	5.0	0.004	0.682
0	5.0	0.018	3.049
-10	5.0	0.009	1.574
-20	5.0	0.012	2.002
-30	5.0	0.005	0.830

ANT1-802.11ac20-CH165

Temperature (°C)	Voltage (DC:V)	Frequency Measure with time Elapsed	
		MCF	(ppm)
50	5.0	0.007	1.150
40	5.0	0.017	2.895
30	5.0	0.017	2.895
20	5.0	0.012	2.131
10	5.0	0.006	0.974
0	5.0	0.012	2.131
-10	5.0	0.006	1.105
-20	5.0	0.013	2.203
-30	5.0	0.012	2.131

ANT1-802.11ac40-CH38

Temperature (°C)	Voltage (DC:V)	Frequency Measure with time Elapsed	
		MCF	(ppm)
50	5.0	0.015	2.841
40	5.0	0.016	3.112
30	5.0	0.005	0.951
20	5.0	0.015	2.841
10	5.0	0.012	2.337
0	5.0	0.015	2.841
-10	5.0	0.016	3.112
-20	5.0	0.004	0.791
-30	5.0	0.009	1.668

ANT1-802.11ac40-CH46

Temperature (°C)	Voltage (DC:V)	Frequency Measure with time Elapsed	
		MCF	(ppm)
50	5.0	0.008	1.461
40	5.0	0.004	0.800
30	5.0	0.001	0.178
20	5.0	0.003	0.545
10	5.0	0.001	0.178
0	5.0	0.012	2.351
-10	5.0	0.013	2.569
-20	5.0	0.011	2.034
-30	5.0	0.006	1.191

ANT1-802.11ac40-CH151

Temperature (°C)	Voltage (DC:V)	Frequency Measure with time Elapsed	
		MCF	(ppm)
50	5.0	0.011	1.898
40	5.0	0.010	1.791
30	5.0	0.001	0.116
20	5.0	0.001	0.116
10	5.0	0.015	2.553
0	5.0	0.013	2.279
-10	5.0	0.009	1.637
-20	5.0	0.017	2.996
-30	5.0	0.010	1.791

ANT1-802.11ac40-CH159

Temperature (°C)	Voltage (DC:V)	Frequency Measure with time Elapsed	
		MCF	(ppm)
50	5.0	0.014	2.468
40	5.0	0.013	2.325
30	5.0	0.001	0.125
20	5.0	0.010	1.698
10	5.0	0.003	0.505
0	5.0	0.006	1.069
-10	5.0	0.016	2.706
-20	5.0	0.015	2.614
-30	5.0	0.009	1.560

ANT1-802.11ac80-CH42

Temperature (°C)	Voltage (DC:V)	Frequency Measure with time Elapsed	
		MCF	(ppm)
50	5.0	0.010	2.002
40	5.0	0.009	1.763
30	5.0	0.002	0.304
20	5.0	0.010	2.002

10	5.0	0.003	0.569
0	5.0	0.008	1.558
-10	5.0	0.013	2.451
-20	5.0	0.012	2.380
-30	5.0	0.005	1.042

ANT1-802.11ac80-CH155

Temperature (°C)	Voltage (DC:V)	Frequency Measure with time Elapsed	
		MCF	(ppm)
50	5.0	0.017	2.930
40	5.0	0.011	1.985
30	5.0	0.012	2.153
20	5.0	0.002	0.302
10	5.0	0.006	1.020
0	5.0	0.011	1.985
-10	5.0	0.009	1.543
-20	5.0	0.005	0.933
-30	5.0	0.001	0.242

10.ANTENNA REQUIREMENT

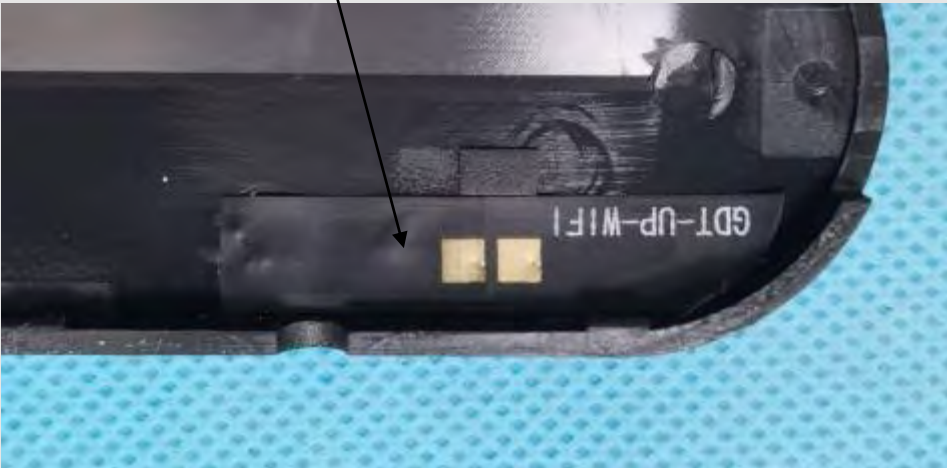
Standard requirement:	FCC Part15 C Section 15.203 /247(c)
<p>For intentional device, according to FCC 47 CFR Section 15.203, an intentional radiator shall be designed to ensure that no antenna other than that furnished by the responsible party shall be used with the device. And according to FCC 47 CFR Section 15.247, if transmitting antennas of directional gain greater than 6dBi are used, the power shall be reduced by the amount in dB that the directional gain of the antenna exceeds 6dBi.</p> <p>Refer to statement below for compliance.</p> <p>The manufacturer may design the unit so that the user can replace a broken antenna, but the use of a standard antenna jack or electrical connector is prohibited. Further, this requirement does not apply to intentional radiators that must be professionally installed.</p> <p>Antenna Connected Construction</p> <p>The antenna used in this product is a FPC antenna, and the best case gain of the antenna is antenna port 1: 1.09dBi</p>	
<p>EUT Antenna:</p> <p>2.4G&5GWIFI ANT</p> 	

11. TEST SETUP PHOTO

Reference to the test setup file for details.

12. EUT CONSTRUCTIONAL DETAILS

Reference to the external photos file and internal photos file for details.

******* END OF REPORT *******