



**moonki**<sup>®</sup>  
S O U N D  
AUDIO PROFESIONAL

MS-115B



HECHO EN RPC

POTENCIA | POWER | POTÊNCIA  
**2500W**

MANUAL DE USUARIO | USER MANUAL | MANUAL DO USUÁRIO

# MS-115B



## Bienvenido al instructivo de su parlante

### 1. Contenido de la caja:

- 1 x Parlante
- 1 x Control remoto
- 1 x Manual de usuario
- 1 x Cable de alimentación
- 1 x Tarjeta de garantía
- 1 X Trípode

### 2. Especificaciones

|  |  |
|--|--|
| Parlante activo con batería recargable | Potencia RMS: 100W                           |
| Woofer de 15"                          | Tweeter: 25mm                                |
| Bobina de 1.5" KSV - Magneto de 850g   | Sensibilidad: 92dB                           |
| Potencia PMPO: 2500W                   | Incluye control remoto + micrófono con cable |

### 3. Especificaciones de Panel

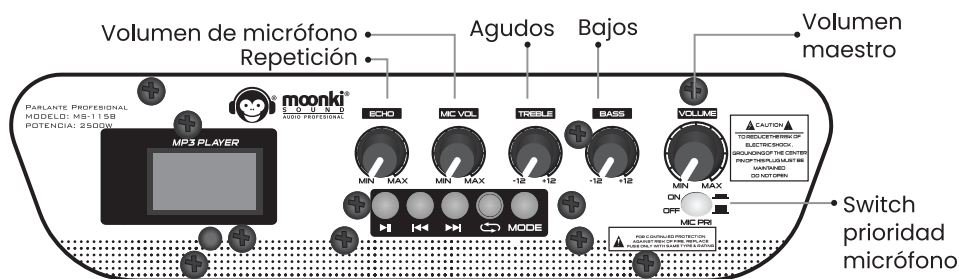

#### **Función de Repetición:**

Se trata de un efecto de eco. Regule que tan marcado sera el efecto. Este efecto aplica únicamente al uso del micrófono.

#### **Agudos/Bajos:**

Regule la intensidad de los sonidos bajos y agudos para lograr un sonido más a gusto. Sirve tanto para la reproducción Mp3 por cualquier medio de reproducción empleado, o el uso del micrófono.

El fabricante se guarda el derecho de modificar las especificaciones sin previo aviso.

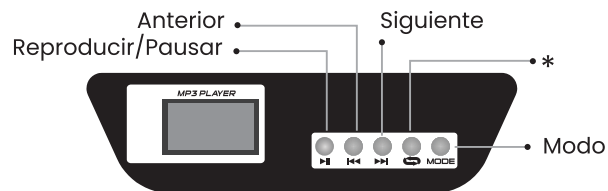
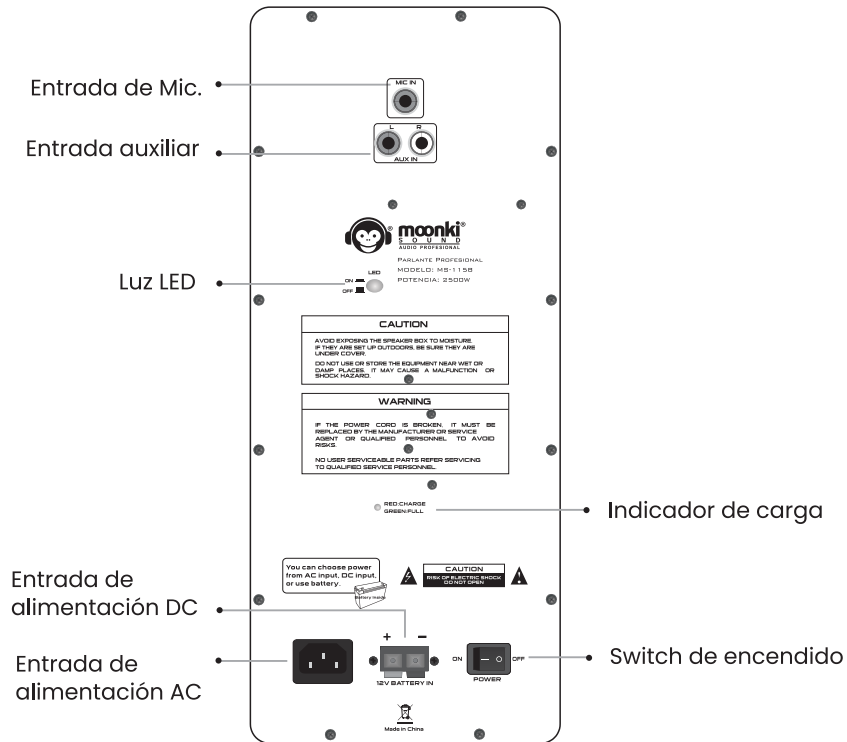

\* Este botón no cumple con ninguna función en las versiones sin USB o tarjeta SD

**Reproducir/Pausar:** Presione para reproducir una canción o para pausarla cuando esta reproduciendo.

**Anterior:** Presione una vez para saltar a la canción anterior, manténgalo para reducir el volumen.

**Siguiente:** Presione una vez para saltar a la canción siguiente, y manténgalo para reducir el volumen.

**Modo:** Seleccione el modo de reproducción, USB, Bluetooth o auxiliar.





## Welcome to yours speaker's instruction guide

### 1. Packing Contents

- 1 x speaker
- 1 x remote control
- 1 x user's guide
- 1 x power cable
- 1 X Tripod

### 2. Specifications

|  |                                   |
|--|-----------------------------------|
| 15" Active speaker box with rechargeable battery             | Tweeter 25mm                      |
| Battery: 12V, 5AH  | Sensitivity: 92dB (+/-3dB)        |
| Woofers: 15" woofer, 30Oz(120mm), 1.5" (38mm) KSV voice coil | Power: 100W                       |
|  | Remote control + Wired microphone |

### 3. Panel Specification

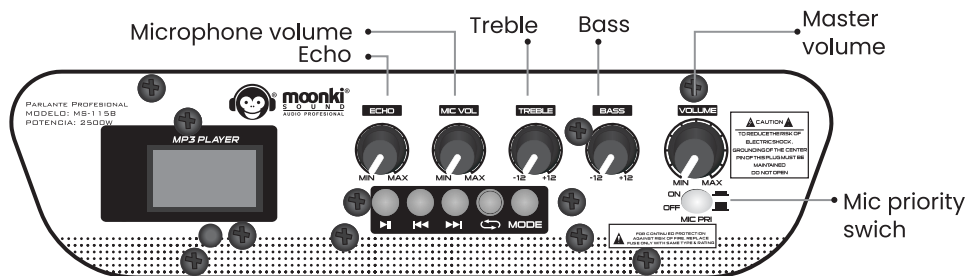

#### **ECHO function:**

It's located on control panel, with eco control. Sing song or talk with eco function will reach good effecton.

#### **Treble / Bass potentiometer:**

Can control the bass, treble of speaker box (line input and mp3 INPUT), also it can control microphone's treble and bass

The manufacturer reserves the right to modify specifications without prior notice.

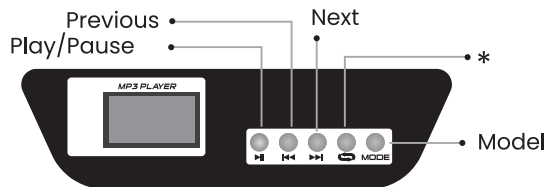
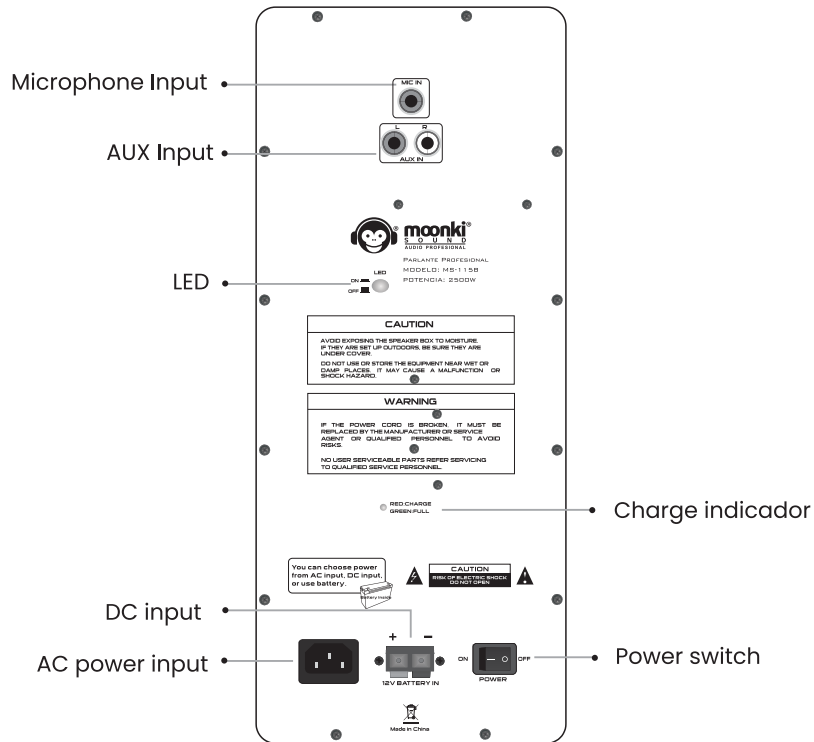

\* This button do not count with any function at all in the speaker version with out USB and SD Card

**Play/Pause:** Press to play a song or pause while playing a song.

**Previous:** Press once to jump previous song/Press and hold to diminish the volume level.

**Next:** Press once tu jump to next song/ press and hold to raise the volume level.

**Model:** Select an operating modality.





## Bem-vindo às instruções do Caixa de som

### 1. Conteúdo da caixa:

- 1 x Caixa de Som
- 1 x Controle remoto
- 1 x Manual do Usuário
- 1 x Cabo de alimentação
- 1 x Cartão de garantia
- 1 x tripé
- 1 x Warranty card

### 2. Especificações

|   |                        |
|---|------------------------|
| Caixa de som ativa com bateria recarregável | Tweeter: 25mm          |
| Woofers de 15"                              | Sensibilidade: 92dB    |
| Bobina KSV de 1,5" - 850g Magneto           | Inclui controle remoto |
| Potência PMPO: 2500W                        | + microfone com cabo   |
| Potência RMS: 100W                          | + tripé                |

### 3. Especificações do Painel

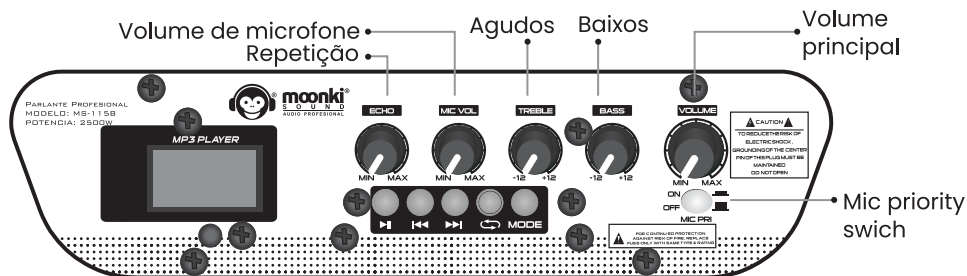

#### Função de repetição:

Este é um efeito de eco. Regular como será marcado o efeito. Este efeito se aplica apenas ao uso do microfone.

#### Agudos/Baixos:

Ajuste a intensidade dos sons graves e agudos para obter um som mais confortável. Serve tanto para a reprodução de MP3 por qualquer meio de reprodução usado quanto para o uso do microfone.

O fabricante reserva-se o direito de modificar especificações sem prévio aviso.

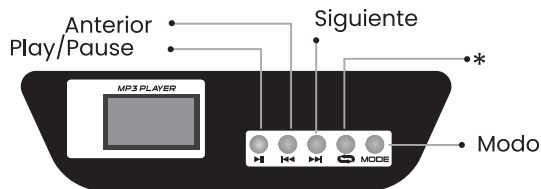
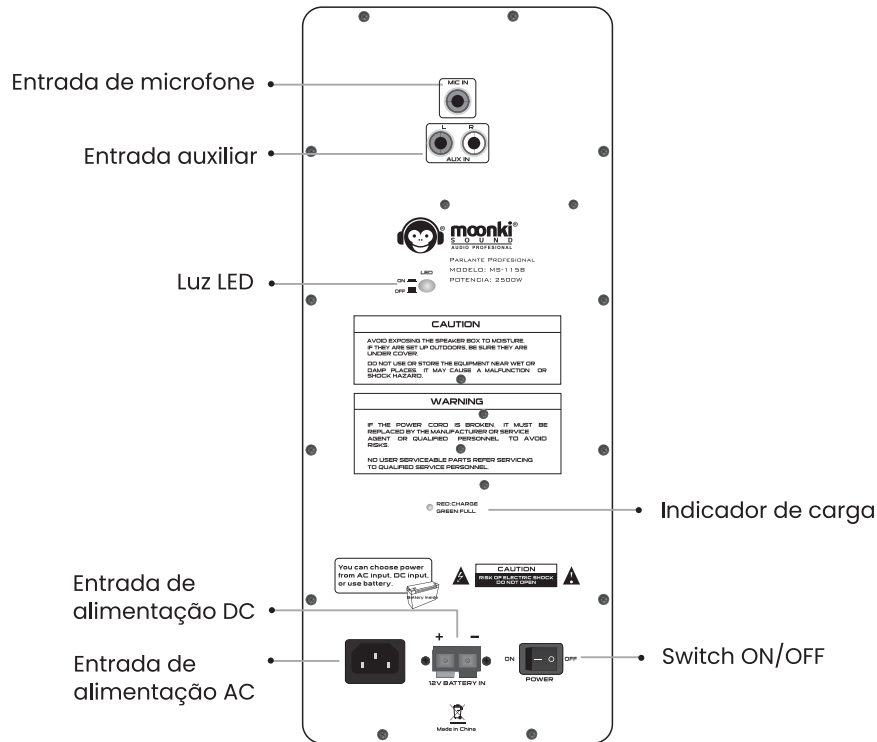

\* Este botón não tem função nas versões sem USB ou cartão SD

**Play/Pause:** Pressione para reproduzir uma música ou para pausar.

**Anterior:** Pressione uma vez para pular para a música anterior, segure-a para reduzir o volume.

**Siguiente:** Pressione uma vez para pular para a próxima música e segure-a para reduzir o volume.

**Modo:** Seleccione o modo de reprodução, USB, Bluetooth ou auxiliar



### Conexión Bluetooth

1. Para emparejar el parlante a un dispositivo bluetooth, presione MODO repetidamente en el display del reproductor hasta seleccionar este modo.
2. Habilite la conexión Bluetooth en su dispositivo.
3. Cuando el dispositivo muestre el parlante en la lista de conexiones, confirme el emparejamiento.

### Connection Bluetooth

1. To pair the speaker with a bluetooth phone or audio device, press "MODE" repeatedly on the MP3 player until select this mode.
2. Put your phone or device to be used in bluetooth device discovery mode.
3. When your phone or device shows the "BLUETOOTH" device, confirm the link.

### Conexão Bluetooth

1. Para emparelhar o alto-falante com um telefone bluetooth ou dispositivo de áudio, pressione "MODE" repetidamente no MP3 player até selecionar este modo.
2. Coloque seu telefone ou dispositivo a ser usado no modo de descoberta de dispositivo bluetooth.
3. Quando seu telefone ou dispositivo mostrar o dispositivo "BLUETOOTH", confirme o link.

### PRECAUCIÓN

Evite exponer el parlante a fuentes de humedad. Si se usa al intemperie, asegúrese que este a buen resguardo.

No use ni almacene este equipo en lugares húmedos, puede ocasionar malfuncionamiento o riesgo de choque eléctrico.

Si el cable de alimentación esta dañado, debe reemplazarse por el fabricante, o un agente abilitado y calificado para evitar riesgos.

Para evitar incendios o riesgo de choque eléctrico, no exponga este equipo a la lluvia o humedad. Limpiar solamente con un paño seco.

### CAUTION

Avoid exposing the speaker box to moisture. If they are set up outdoors, Be Sure they are under cover.

Do not use nor store the equipment near wet or damp places. It may cause a malfunction or shock hazard.

If the power cord is broken, it must be replaced by the manufacturer or service agent or qualified personnel to avoid risks.

To reduce the risk of fire or electric shock, do not expose this equipment to rain or moisture.

Clean only with a soft, dry cloth.



PRECAUCIÓN: ANTES DE USAR ESTE PARLANTE, CARGUE COMPLETAMENTE LA BATERÍA, PARA MEJORAR LA VIDA DE LA MISMA. NO REPRODUZCA EL PARLANTE Y CARGUE LA BATERÍA AL MISMO TIEMPO. ESTO AFECTARÁ LA VIDA DE LA MISMA.



CAUTION: BEFORE USE SPEAKER BOX, PLEASE CHARGE BATTERY FULLY, IT IS BETTER FOR BATTERY LIFE. DON'T PLAY SPEAKER BOX AND CHARGE BATTERY AT THE SAME TIME, OTHERWISE IT WILL AFFECT BATTERY LIFE.



CUIDADO: ANTES DE USAR ESTE ALTIFALANTE, CARREGUE TOTALMENTE A BATERIA PARA MELHORAR A VIDA ÚTIL DA BATERIA. NÃO TOQUE O ALTIFALANTE E CARREGUE A BATERIA AO MESMO TEMPO. ISSO AFETARÁ A VIDA DO MESMO.



MS-115B



This device complies with Part 15 of the FCC Rules. Operation is subject to the following two conditions:

- (1) this device may not cause harmful interference, and
- (2) this device must accept any interference received, including interference that may cause undesired operation

This device should be installed and operated with a minimum distance of 20cm between the antenna and all persons.

This device has been tested and found to comply with the limits for a Class B digital device, pursuant to Part 15 of the FCC Rules. These limits are designed to provide reasonable protection against harmful interference in a residential installation. This device generates, uses and can radiate radio frequency energy and, if not installed and used in accordance with the instructions, may cause harmful interference to radio communications.

However, there is no guarantee that interference will not occur in a particular installation. If this device does cause harmful interference to radio or television reception, which can be determined by turning the device off and on, the user is encouraged to try to correct the interference by one or more of the following measures:

- Reorient or relocate the receiving antenna.
- Increase the separation between the device and receiver.
- Connect the device into an outlet on a circuit different from that to which the receiver is connected.
- Consult the dealer or an experienced radio/TV technician for help

Changes or modifications not expressly approved by the party responsible for compliance could void the user's authority to operate the equipment