

SAMPLE APPROVAL SHEET

SPECIFICATION FOR APPROVAL

Supplier	Shenzhen TaoSOFT Electronics Co. LTD
Model Name	A11 coil
Part Name	A11

DESC	13.5x42-14Ts-0.08*105-20mm-CLB	Rev: A 0	CUST:	
			Fine P/N:	
			CUST P/N:	

一、尺寸 DIMENSION:(mm)

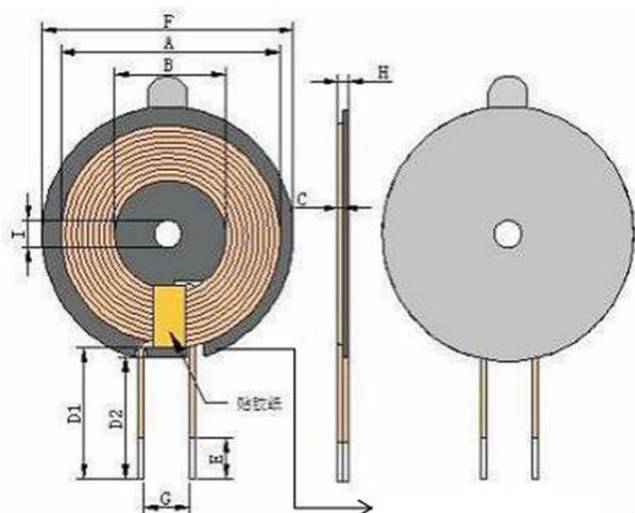

A	42.0±1
B	13.5±0.5
C	0.8+/-0.05
D1	22±1
D2	20±1
E	3±1.5
F	43.5±0.5
G	11.0 ref
H	2.2±0.2 Max
I	5.0 ref

Note:
 1. Coil magnet, magnet size 43.3±0.5mm, inner hole 5.0mm, thickness 0.8+/- 0.5mm, double groove
 2. The winding width at the exit position of the coil is 8mm ±0.5 high temperature adhesive paper.
 3. The circular diameter of the back of the magnet is 43.0 mm(ref), and the inner hole is 7.0 mm(ref) ordinary double-sided glue.

The front is pasted with PVC black film

二、原理图 SCHEMATIC DIAGRAM:



三、绕线参数 Winding Specification:

NO	TERMINAL		WIRE	Turns	Winding Direction
1	S	F	0.08*105P	14Ts	CCW

四、电气特性 ELECTRICAL CHARACTERISTICS:

温度 TEMPERATURE : 25 ± 10 °C, 湿度 RELATIVE HUMIDITY : 65 ± 20%

序号 NO	项目 ITEM	端子 TERMINAL	标准 SPECIFICATION	测试条件 TEST FREQUENCY	测试仪器 TEST EQUIPMENTS
1	IND.	S-F	5.5 uH ±20%	100KHz/ 1.0V	LCZ METER 1062B
2	IND.	S-F	10uH ± 10%	100KHz/ 1.0V	LCZ METER 1062B
3	Q 值	S-F	≤110(ref)	100KHz/ 1.0V	LCZ METER 1062B
4	DCR	S-F	≤70m Ω		LCZ METER 502 B

拟制/日期 PREPARED BY/DATE	审核/日期 CHECKED BY/DATE
冯伯群 2023/12/06	苏燕平 2023/12/06
