

TEST REPORT

Product Name : X1E
Model Number : PF001-E
FCC ID : 2A6J8-PF001E
IC : 28436-PF001E

Prepared for : Shenzhen Tuozhu Technology Co., Ltd.
Address : Room 201, Building A, No. 1 First Qianwan Road, Qianhai
Shengang Cooperation Zone, Shenzhen

Prepared by : EMTEK (SHENZHEN) CO., LTD.
Address : Building 69, Majialong Industry Zone, Nanshan District,
Shenzhen, Guangdong, China

Tel: (0755) 26954280
Fax: (0755) 26954282

Report Number : ENS2306300139W00401R
Date(s) of Tests : July 14, 2023 to August 14, 2023
Date of issue : August 15, 2023

TABLE OF CONTENTS

1	TEST RESULT CERTIFICATION	3
2	EUT TECHNICAL DESCRIPTION	5
3	SUMMARY OF TEST RESULT	6
4	TEST METHODOLOGY	7
4.1	GENERAL DESCRIPTION OF APPLIED STANDARDS	7
4.2	MEASUREMENT EQUIPMENT USED	7
4.3	DESCRIPTION OF TEST MODES	8
5	FACILITIES AND ACCREDITATIONS	9
5.1	FACILITIES	9
5.2	EQUIPMENT	9
5.3	LABORATORY ACCREDITATIONS AND LISTINGS	9
6	TEST SYSTEM UNCERTAINTY	10
7	SETUP OF EQUIPMENT UNDER TEST	11
7.1	RADIO FREQUENCY TEST SETUP 1	11
7.2	RADIO FREQUENCY TEST SETUP 2	11
7.3	CONDUCTED EMISSION TEST SETUP	14
7.4	BLOCK DIAGRAM CONFIGURATION OF TEST SYSTEM	15
7.5	SUPPORT EQUIPMENT	15
8	TEST REQUIREMENTS	16
1.1	ON TIME AND DUTY CYCLE	16
8.1	DTS 6DB BANDWIDTH	21
8.2	DTS 99% BANDWIDTH	26
8.3	MAXIMUM PEAK CONDUCTED OUTPUT POWER	31
8.4	MAXIMUM POWER SPECTRAL DENSITY	37
8.5	UNWANTED EMISSIONS IN NON-RESTRICTED FREQUENCY BANDS	43
8.6	RADIATED SPURIOUS EMISSION	51
8.7	CONDUCTED EMISSION TEST	65
8.8	ANTENNA APPLICATION	68

1 TEST RESULT CERTIFICATION

Applicant : Shenzhen Tuozhu Technology Co., Ltd.
 Address : Room 201, Building A, No. 1 First Qianwan Road, Qianhai Shengang Cooperation Zone, Shenzhen
 Manufacturer : Shenzhen Tuozhu Technology Co., Ltd.
 Address : Room 201, Building A, No. 1 First Qianwan Road, Qianhai Shengang Cooperation Zone, Shenzhen
 EUT : X1E
 Model Name : PF001-E
 Trademark : bambulab

Measurement Procedure Used:

APPLICABLE STANDARDS	
STANDARD	TEST RESULT
FCC 47 CFR Part 2 , Subpart J FCC 47 CFR Part 15, Subpart C	PASS
IC RSS-GEN, Issue 5(04-2018)+A1(03-2019)+A2(02-2021) IC RSS-247 Issue 2(02-2017)	PASS

The above equipment was tested by EMTEK(SHENZHEN) CO., LTD. The test data, data evaluation, test procedures, and equipment configurations shown in this report were made in accordance with the procedures given in ANSI C63.10 (2013) and the energy emitted by the sample EUT tested as described in this report is in compliance with the requirements of FCC Rules Part 2, Part 15.247, IC RSS-247 Issue 2 and IC RSS-GEN, Issue 5.

The test results of this report relate only to the tested sample identified in this report.

Date of Test : July 14, 2023 to August 14, 2023

Prepared by : 
 Una Yu /Editor

Reviewer : 
 Sevin Li /Supervisor

Approve & Authorized Signer : 
 Lisa Wang/Manager



Modified History

Version	Report No.	Revision Date	Summary
V1.0	ENS2306300139W00401R	/	Original Report



2 EUT TECHNICAL DESCRIPTION

Characteristics	Description
Product:	X1E
Model Number:	PF001-E
Sample Number:	2#
IEEE 802.11 WLAN Mode Supported:	802.11b 802.11g 802.11n(20MHz channel bandwidth)
Modulation:	DSSS with DBPSK/DQPSK/CCK for 802.11b; OFDM with BPSK/QPSK/16QAM/64QAM for 802.11g/n;
Operating Frequency Range:	2412-2462MHz for 802.11b/g/n(HT20);
Number of Channels:	11 channels for 802.11b/g/n(HT20);
Transmit Power Max:	17.86 dBm
Antenna Type:	PCB Antenna
Antenna Gain:	5.2 dBi
FVIN	V01.00.00.00
Power Supply:	100-240V~ 5A 50/60Hz
Date of Received	July 13, 2023
Temperature Range	0°C ~ +40°C

Note: for more details, please refer to the User's manual of the EUT.

3 SUMMARY OF TEST RESULT

FCC Part Clause	IC Part Clause	Test Parameter	Verdict	Remark
15.247(a)(2)	RSS-247 5.2(a) RSS-Gen 6.7	Emission Bandwidth	PASS	*
15.247(b)(3)	RSS-247 5.4(d) RSS-Gen 6.12	Maximum Peak Conducted Output Power	PASS	*
15.247(e)	RSS-247 5.2(b) RSS-Gen 6.12	Maximum Power Spectral Density Level	PASS	*
15.247(d)	RSS-247 5.5	Unwanted Emission Into Non-Restricted Frequency Bands	PASS	*
15.247(d)	RSS-247 5.5	Unwanted Emission Into Restricted Frequency Bands (conducted)	PASS	*
15.247(d) 15.209 15.205	RSS-Gen 8.9 RSS-Gen 8.10 RSS-Gen 6.13 RSS-247 3.3 RSS-247 5.5	Radiated Spurious Emission	PASS	
15.207	RSS-Gen 8.8	Conducted Emission Test	PASS	
15.203 15.247(b)	RSS-Gen 6.8 RSS-247 5.4	Antenna Application	PASS	*
NOTE1: N/A (Not Applicable) NOTE2: According to FCC OET KDB 558074, the report use radiated measurements in the restricted frequency bands. In addition, the radiated test is also performed to ensure the emissions emanating from the device cabinet also comply with the applicable limits. NOTE3: Remark * these modules have been tested and comply with RSS requirements, Only retest radiated spurious emission and conducted emission, with all other data referred to the original report ENS2209050063W00302R				

RELATED SUBMITTAL(S) / GRANT(S):

This submittal(s) (test report) is intended for **FCC ID: 2A6J8-PF001E** filing to comply with Section 15.247 of the FCC Part 15, Subpart C Rules.

This submittal(s) (test report) is intended for **IC: 28436-PF001E** filing to comply with RSS-247 Rules.

4 TEST METHODOLOGY

4.1 GENERAL DESCRIPTION OF APPLIED STANDARDS

According to its specifications, the EUT must comply with the requirements of the following standards:

FCC 47 CFR Part 2, Subpart J

FCC 47 CFR Part 15, Subpart C

IC RSS-GEN, Issue 5(04-2018)+A1(03-2019)+A2(02-2021)

IC RSS-247 Issue 2(02-2017)

FCC KDB 558074 D01 15.247 Meas Guidance v05r02

FCC KDB 662911 D01 Multiple Transmitter Output v02r01

4.2 MEASUREMENT EQUIPMENT USED

Conducted Emission Test Equipment

Equipment	Manufacturer	Model No.	Serial No.	Last Cal.	Cal. Interval
Test Receiver	Rohde & Schwarz	ESCI	101384	2023/5/13	1 Year
L.I.S.N.	Rohde & Schwarz	ENV216	101161	2023/5/13	1 Year
L.I.S.N.	Kyoritsu	KNW-407	8-1492-9	2023/5/11	1 Year

For Spurious Emissions Test

Equipment	Manufacturer	Model No.	Serial No.	Last Cal.	Cal. Interval
EMI Test Receiver	Rohde & Schwarz	ESU 26	100154	2023/5/13	1 Year
Pre-Amplifie	Lunar EM	LNA30M3G-25	J10100000070	2023/5/13	1 Year
Bilog Antenna	Schwarzbeck	VULB9163	661	2023/6/2	2 Year
Horn antenna	Schwarzbeck	BBHA9120D	9120D-1177	2023/5/12	2 Year
Pre-Amplifie	SKET	LNPA_0118G-45	SK2019051801	2023/5/10	1 Year
Loop Antenna	Schwarzbeck	FMZB1519	1519-012	2023/5/12	2 Year
Spectrum Analyzer	Rohde & Schwarz	FSV40	100967	2023/5/10	1 Year
Horn antenna	Schwarzbeck	BBHA9120D	9120D-1178	2023/5/10	2 Year
Band reject Filter(50dB)	WI/DE	WRCGV-2400(2400-2485MHz)	2	2023/5/13	1 Year

For other test items:

Equipment	Manufacturer	Model No.	Serial No.	Last Cal.	Cal. Interval
Wideband Radio Communication Tester	R&S	CMW500	171168	2022/11/2	1Year
Frequency Extender	R&S	CMW-Z800A	100430	2022/11/2	1Year
Spectrum Analyzer	R&S	FSV3044	101289	2022/11/2	1Year
Analog Signal Generator	R&S	SMB100A	183237	2022/11/2	1Year
Vector Signal Generator	R&S	SMM100A	101808	2022/11/2	1Year
RF Control Unit(Power Meter)	Tonscend	JS0806-2	22C8060567	2022/11/2	N/A
Temperature&Humidity Chamber	ESPEC	EL-02KA	12107166	2023/5/10	1 Year

4.3 DESCRIPTION OF TEST MODES

The EUT has been tested under its typical operating condition.

The EUT configuration for testing is installed on RF field strength measurement to meet the Commissions requirement and operating in a manner which intends to maximize its emission characteristics in a continuous normal application.

The Transmitter was operated in the normal operating mode. The TX frequency was fixed which was for the purpose of the measurements.

Test of channel included the lowest and middle and highest frequency to perform the test, then record on this report.

Those data rates (802.11b: 1 Mbps; 802.11g: 6 Mbps; 802.11n (HT20): MCS0;) were used for all test.

Pre-defined engineering program for regulatory testing used to control the EUT for staying in continuous transmitting and receiving mode is programmed.

Frequency and Channel list for 802.11 b/g/n(HT20):

Channel	Frequency (MHz)	Channel	Frequency (MHz)	Channel	Frequency (MHz)
1	2412	5	2432	9	2452
2	2417	6	2437	10	2457
3	2422	7	2442	11	2462
4	2427	8	2447		

Test Frequency and Channel for 802.11 b/g/n(HT20):

Lowest Frequency		Middle Frequency		Highest Frequency	
Channel	Frequency (MHz)	Channel	Frequency (MHz)	Channel	Frequency (MHz)
1	2412	6	2437	11	2462

Multi-antenna correlation:

<input type="checkbox"/>	Transmit Signals are Correlated
	Directional gain = $10 \log[(10^{G1/20} + 10^{G2/20} + \dots + 10^{GN/20})^2 / N_{ANT}]$ dBi
<input type="checkbox"/>	All Transmit Signals are Completely Uncorrelated
	Directional gain = $10 \log[(10^{G1/10} + 10^{G2/10} + \dots + 10^{GN/10}) / N_{ANT}]$ dBi

5 FACILITIES AND ACCREDITATIONS

5.1 FACILITIES

All measurement facilities used to collect the measurement data are located at:

EMTEK (Shenzhen) Co., Ltd.

Building 69, Majialong Industry Zone District, Nanshan District, Shenzhen, China

The sites are constructed in conformance with the requirements of ANSI C63.7, ANSI C63.4 and CISPR Publication 22.

5.2 EQUIPMENT

Radiated emissions are measured with one or more of the following types of linearly polarized antennas: tuned dipole, biconical, log periodic, bi-log, and/or ridged waveguide, horn. Spectrum analyzers with preselectors and quasi-peak detectors are used to perform radiated measurements.

Conducted emissions are measured with Line Impedance Stabilization Networks and EMI Test Receivers.

Calibrated wideband preamplifiers, coaxial cables, and coaxial attenuators are also used for making measurements.

All receiving equipment conforms to CISPR Publication 16-1, "Radio Interference Measuring Apparatus and Measurement Methods."

5.3 LABORATORY ACCREDITATIONS AND LISTINGS

Site Description

EMC Lab. : **Accredited by CNAS**
 The Certificate Registration Number is L2291.
 The Laboratory has been assessed and proved to be in compliance with CNAS-CL01 (identical to ISO/IEC 17025:2017)

Accredited by FCC
 Designation Number: CN1204
 Test Firm Registration Number: 882943

Accredited by A2LA
 The Certificate Number is 4321.01.

Accredited by Industry Canada
 The Conformity Assessment Body Identifier is CN0008

Name of Firm : EMTEK (SHENZHEN) CO., LTD.

Site Location : Building 69, Majialong Industry Zone,
 Nanshan District, Shenzhen, Guangdong, China

6 TEST SYSTEM UNCERTAINTY

The following measurement uncertainty levels have been estimated for tests performed on the apparatus:

Test Parameter	Measurement Uncertainty
Radio Frequency	$\pm 1 \times 10^{-5}$
Maximum Peak Output Power Test	$\pm 1.0\text{dB}$
Conducted Emissions Test	$\pm 2.0\text{dB}$
Radiated Emission Test	$\pm 2.0\text{dB}$
Power Density	$\pm 2.0\text{dB}$
Occupied Bandwidth Test	$\pm 1.0\text{dB}$
Band Edge Test	$\pm 3\text{dB}$
All emission, radiated	$\pm 3\text{dB}$
Antenna Port Emission	$\pm 3\text{dB}$
Temperature	$\pm 0.5^\circ\text{C}$
Humidity	$\pm 3\%$

Measurement Uncertainty for a level of Confidence of 95%

7 SETUP OF EQUIPMENT UNDER TEST

7.1 RADIO FREQUENCY TEST SETUP 1

The WLAN component's antenna ports(s) of the EUT are connected to the measurement instrument per an appropriate attenuator. The EUT is controlled by PC/software to emit the specified signals for the purpose of measurements.

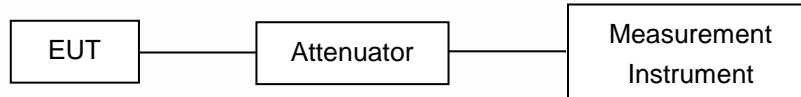

7.2 RADIO FREQUENCY TEST SETUP 2

The test site semi-anechoic chamber has met the requirement of NSA tolerance 4 dB according to the standards: ANSI C63.10. The test distance is 3m. The setup is according to the requirements in Section 13.1.4.1 of ANSI C63.10-2013 and CAN/CSA-CEI/IEC CISPR 22.

The maximal emission value is acquired by adjusting the antenna height, polarisation and turntable azimuth. Normally, the height range of antenna is 1 m to 4 m, the azimuth range of turntable is 0° to 360°, and the receive antenna has two polarizations Vertical (V) and Horizontal (H).

Below 30MHz:

The EUT is placed on a turntable 0.8 meters above the ground in the chamber, 3 meter away from the antenna (loop antenna). The Antenna should be positioned with its plane vertical at the specified distance from the EUT and rotated about its vertical axis for maximum response at each azimuth about the EUT. The center of the loop shall be 1 m above the ground. For certain applications, the loop antenna plane may also need to be positioned horizontally at the specified distance from the EUT.

Above 30MHz:

The EUT is placed on a turntable 0.8 meters above the ground in the chamber, 3 meter away from the antenna. The maximal emission value is acquired by adjusting the antenna height, polarisation and turntable azimuth. Normally, the height range of antenna is 1 m to 4 m, the azimuth range of turntable is 0° to 360°, and the receive antenna has two polarizations Vertical (V) and Horizontal (H).

Above 1GHz:

The EUT is placed on a turntable 1.5 meters above the ground in the chamber, 3 meter away from the antenna. The maximal emission value is acquired by adjusting the antenna height, polarisation and turntable azimuth. Normally, the height range of antenna is 1 m to 4 m, the azimuth range of turntable is 0° to 360°, and the receive antenna has two polarizations Vertical (V) and Horizontal (H).

Measurements shall be taken, using the following steps, at a test site that has been validated using the procedures of ANSI C63.4 or the latest CISPR 16-1-4 for measurements above 1 GHz, so as to simulate a near free-space environment (see RSS-Gen for applicable versions of ANSI and CISPR standards).

(1) Line the ground plane with absorbers between the transmitter and the receive antenna to minimize reflections. The absorbers used should have a minimum-rated attenuation of 20 dB through the measurement frequency range of interest. The absorbers shall be positioned to replicate the layout used when compliance with the applicable acceptability criterion was achieved, as set forth in the aforementioned standards on site validation.

(2) Set the height of the receive antenna to 1.5 m. The receive antenna must be one that was designed and fabricated to operate over the entire frequency range of interest, for example, an appropriate standard gain horn.

(3) The distance between the receive antenna and the radiating source shall be sufficient in order to ensure far-field conditions.

(4) Mount the transmitter at a height of 1.5 m.

(5) Configure the device under test (DUT) to produce the maximum power spectral density as measured while assessing compliance with Section 6.2.2 (i.e. channel frequency, modulation type and data rate). If the DUT is equipped with a detachable antenna and the antenna is intended for remote installation (i.e. tower-mounted), the DUT may be substituted with a suitable signal generator. The level and frequency

settings on the generator shall be set so as to reproduce the maximum power spectral density, measured within a 1 MHz bandwidth, obtained while assessing compliance to Section 6.2.2.

(6) Position the transmitter or the radiating antenna so that elevation pattern measurements can be taken.

(7) Find the 0° reference point in the horizontal plane.

(8) Care should be taken when positioning the receive antenna to avoid cross-polarization. Antennas of known mounting polarization should be assessed with the receive antenna oriented in the same polarity. If the polarization of the transmit antenna is unknown or the transmit antenna can be mounted in either polarization, e.i.r.p. measurements should be performed to find which mounting polarity provides the highest e.i.r.p. value. Testing shall be carried out with the receive antenna and the DUT mounted in each polarity.

(9) The emission shall be centred on the display of the spectrum analyzer with the following settings:

i. If the power spectral density of the DUT was assessed with a peak detector and the antenna cannot be detached from the DUT, the spectrum analyzer shall be set to a peak detector with a resolution bandwidth and video bandwidth of 1 MHz.

ii. If the power spectral density of the DUT was assessed using a sample detector with power averaging and the antenna cannot be detached from the DUT, the spectrum analyzer shall be set to a sample detector, configured to produce 100 power averages and set with a resolution bandwidth, as well as a video bandwidth of 1 MHz.

iii. If the antenna can be detached from the DUT, a continuous wave (CW) signal equal to that of the power spectral density measurement may be used, the spectrum analyzer shall be set to peak detector with a resolution bandwidth and video bandwidth of 1 MHz.

(10) Rotate the turntable 360° recording the field strength at each step. Throughout the main beam of the antenna, the step size shall be kept to a maximum of 1°.

Once outside the main beam of the antenna, the maximum step size shall be as follows, when compared to the requirements of Section 6.2.2:

i. Between 0° and 8°, maximum step size of 2°;

ii. Between 8° and 40°, maximum step size of 4°;

iii. Between 40° and 45°, maximum step size of 1°;

iv. Between 45° and 90°, maximum step size of 5°.

Once the mask reaches 90°, the mask will be inverted and the step size will follow in the same manner as above.

For the purpose of this procedure, the main beam of the antenna is defined as the 3 dB beamwidth.

(11) Convert the measured field strength values in terms of e.i.r.p. density (dBW/1 MHz) using the following equation:

$$\text{e.i.r.p. density (dBW/MHz)} = 10 \log((E \cdot r)^2 / 30)$$

E = field strength in V/m

r = measurement distance in metres

(12) Plot the results against the emission mask with reference to the horizontal plane.

(13) Using the plot, the 0° can be rotated to determine the worst-case installation tilt angle.

(14) Testing shall be performed using the highest gain antenna for every antenna type, if applicable.

(15) Antenna type(s), antenna model number(s), and worst-case tilt angle(s) necessary to remain compliant with the elevation mask requirement set forth in Section 6.2.2(3) of RSS-247 shall be clearly indicated in the user manual.

The following figure is an example of a polar elevation mask measured using the Method 1 reference to dB μ V/m at 3 m.

(a) Radiated Emission Test Set-Up, Frequency Below 30MHz

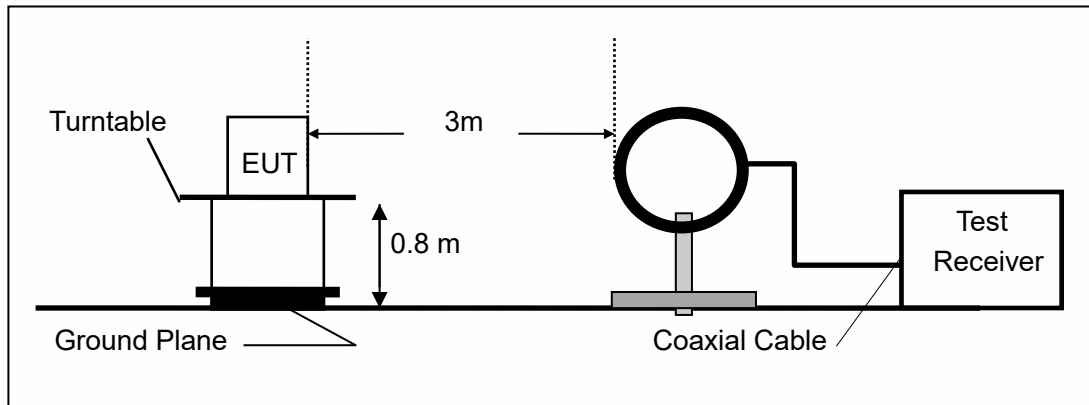

(b) Radiated Emission Test Set-Up, Frequency Below 1000MHz

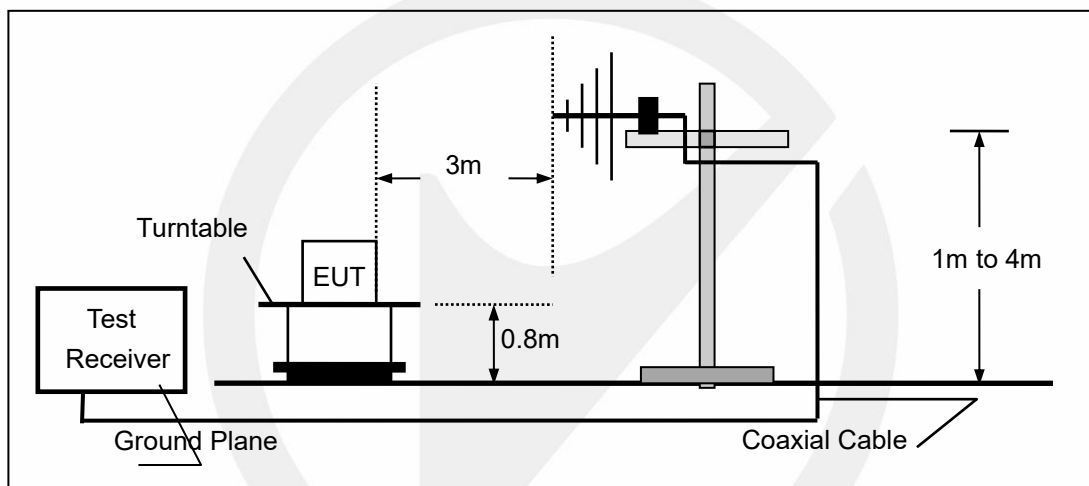

(c) Radiated Emission Test Set-Up, Frequency above 1000MHz

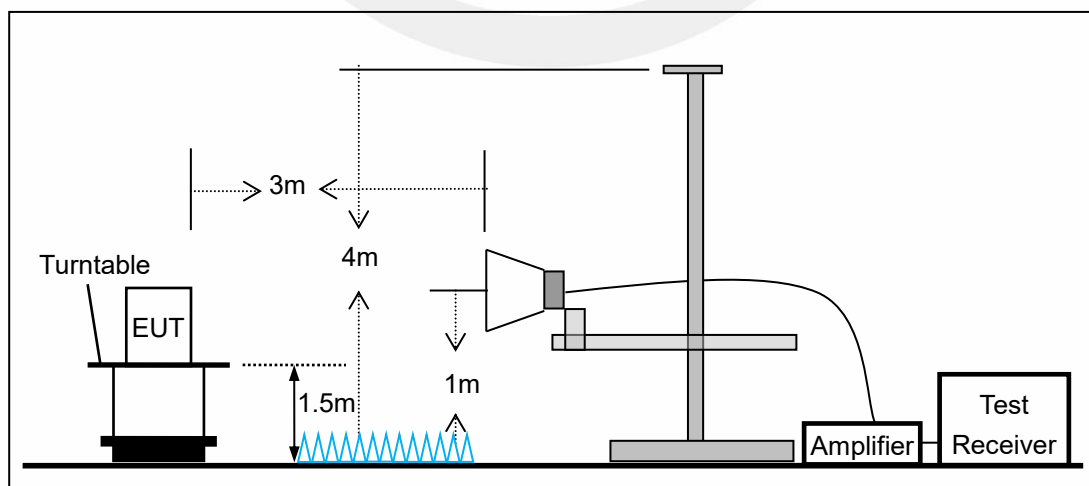

7.3 CONDUCTED EMISSION TEST SETUP

The mains cable of the EUT (maybe per AC/DC Adapter) must be connected to LISN. The LISN shall be placed 0.8 m from the boundary of EUT and bonded to a ground reference plane for LISN mounted on top of the ground reference plane. This distance is between the closest points of the LISN and the EUT. All other units of the EUT and associated equipment shall be at least 0.8m from the LISN.

Ground connections, where required for safety purposes, shall be connected to the reference ground point of the LISN and, where not otherwise provided or specified by the manufacturer, shall be of same length as the mains cable and run parallel to the mains connection at a separation distance of not more than 0.8 m.

According to the requirements in Section 13.1.4.1 of ANSI C63.10-2013 Conducted emissions from the EUT measured in the frequency range between 0.15 MHz and 30 MHz using CISPR Quasi-Peak and average detector mode.

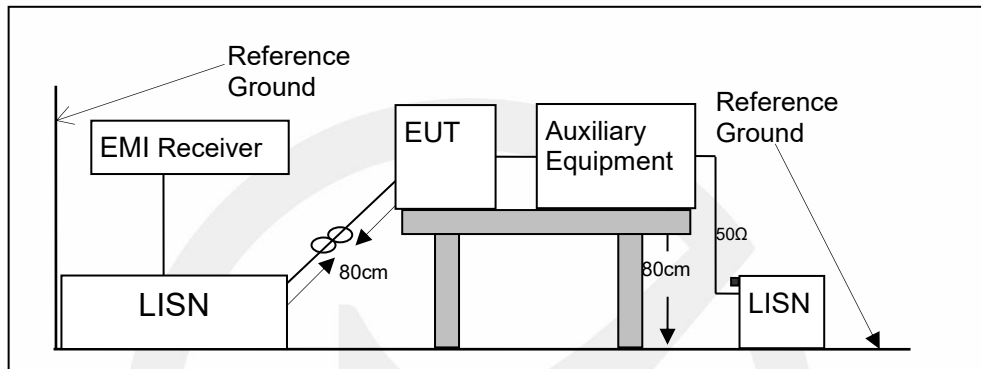

7.4 BLOCK DIAGRAM CONFIGURATION OF TEST SYSTEM

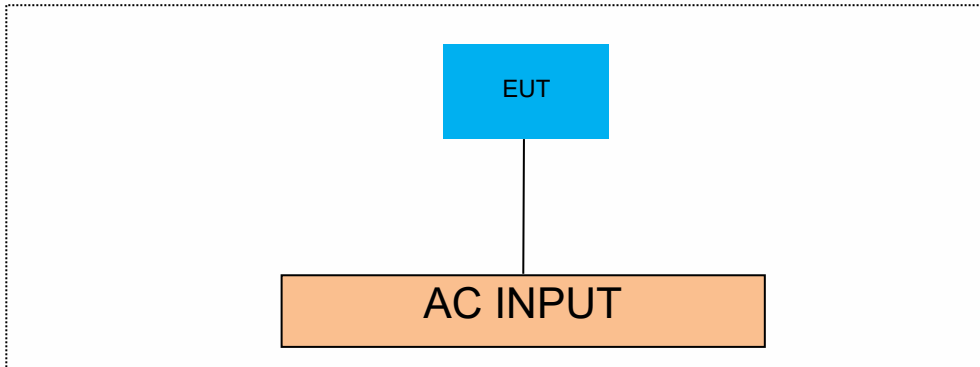

7.5 SUPPORT EQUIPMENT

EUT Cable List and Details			
Cable Description	Length (m)	Shielded/Unshielded	With / Without Ferrite
/	/	/	/

Auxiliary Cable List and Details			
Cable Description	Length (m)	Shielded/Unshielded	With / Without Ferrite
/	/	/	/

Auxiliary Equipment List and Details			
Description	Manufacturer	Model	Serial Number
/	/	/	/

Notes:

1. All the equipment/cables were placed in the worst-case configuration to maximize the emission during the test.
2. Grounding was established in accordance with the manufacturer's requirements and conditions for the intended use.

8 TEST REQUIREMENTS

8.1 ON TIME AND DUTY CYCLE

8.1.1 Applicable Standard

According to 558074 D01 Section 6

8.1.2 Conformance Limit

N/A; for reporting purposes only.

8.1.3 Test Configuration

Test according to clause 7.1 radio frequency test setup.

8.1.4 Test Procedure

The zero-span mode on a spectrum analyzer or EMI receiver, if the response time and spacing between bins on the sweep are sufficient to permit accurate measurements of the on and off times of the transmitted signal. Set the center frequency of the instrument to the center frequency of the transmission. Set RBW \geq EBW if possible; otherwise, set RBW to the largest available value. Set VBW \geq RBW. Set detector = peak or average. The zero-span measurement method shall not be used unless both RBW and VBW are $> 50/T$, where T is the minimum transmission duration over which the transmitter is on and is transmitting at its maximum power control level for the tested mode of operation), and the number of sweep points across duration T exceeds 100. (For example, if VBW and/or RBW are limited to 3 MHz, then the zero-span method of measuring duty cycle shall not be used if $T \leq 16.7$ microseconds.)

8.1.5 Test Results

Temperature:	25°C
Relative Humidity:	45%
ATM Pressure:	1011 mbar

Note: N/A

TestMode	Antenna	Frequency[MHz]	Transmission Duration [ms]	Transmission Period [ms]	Duty Cycle [%]
11B	Ant1	2412	8.42	8.52	98.83
		2437	8.41	8.52	98.71
		2462	8.43	8.52	98.94
11G	Ant1	2412	1.39	1.49	93.29
		2437	1.39	1.50	92.67
		2462	1.39	1.50	92.67
11N20SISO	Ant1	2412	1.31	1.41	92.91
		2437	1.31	1.41	92.91
		2462	1.31	1.40	93.57

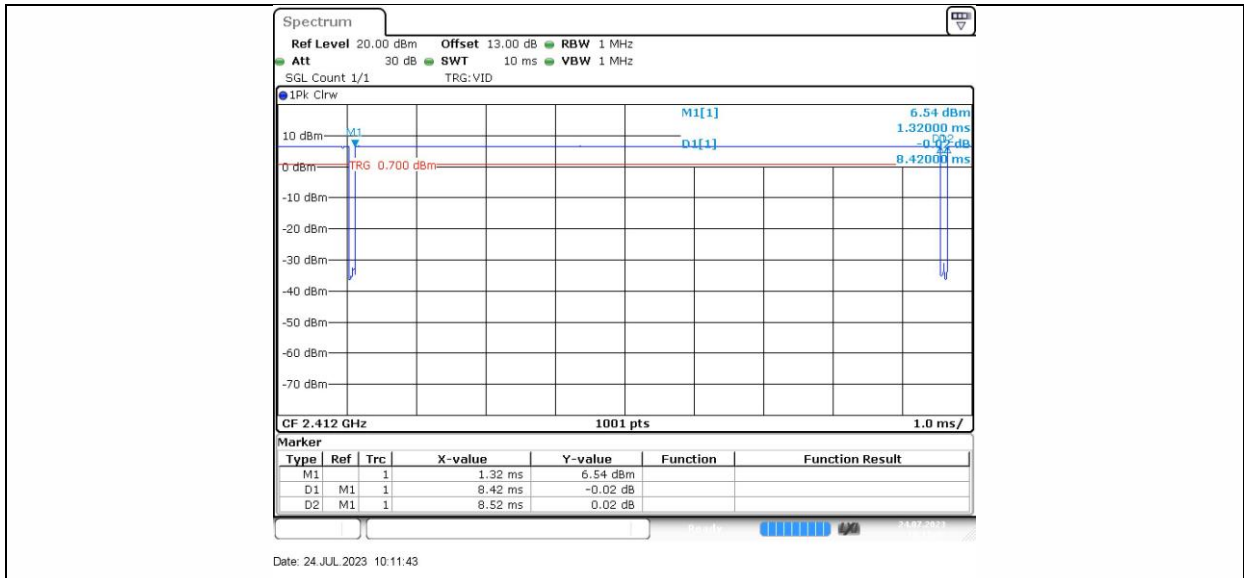

11B Ant1_2412

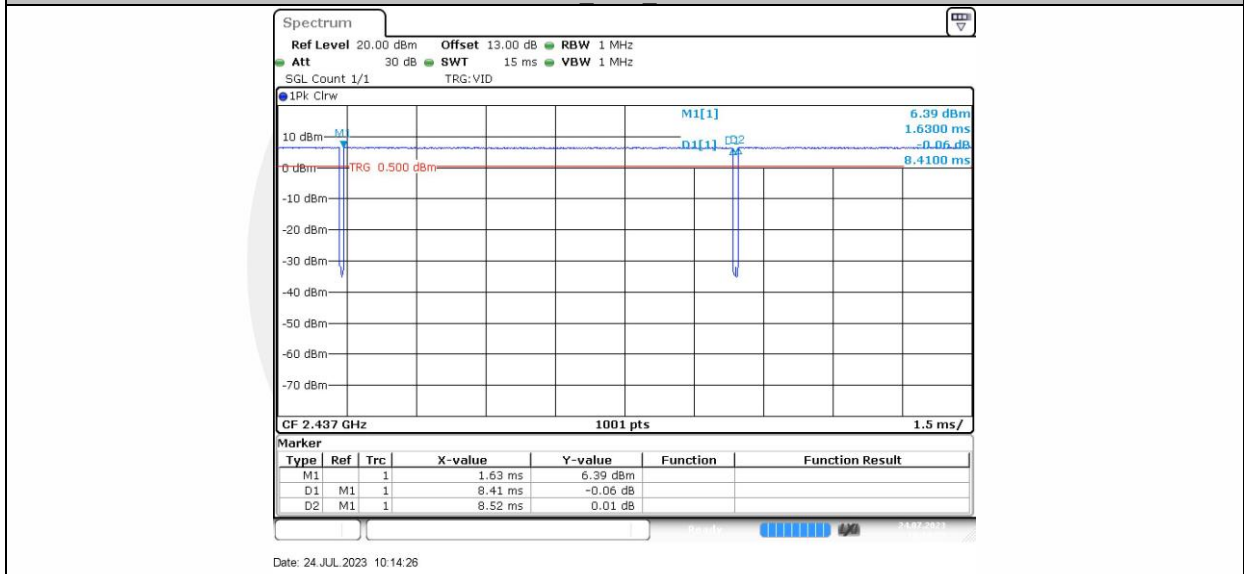

11B Ant1_2437

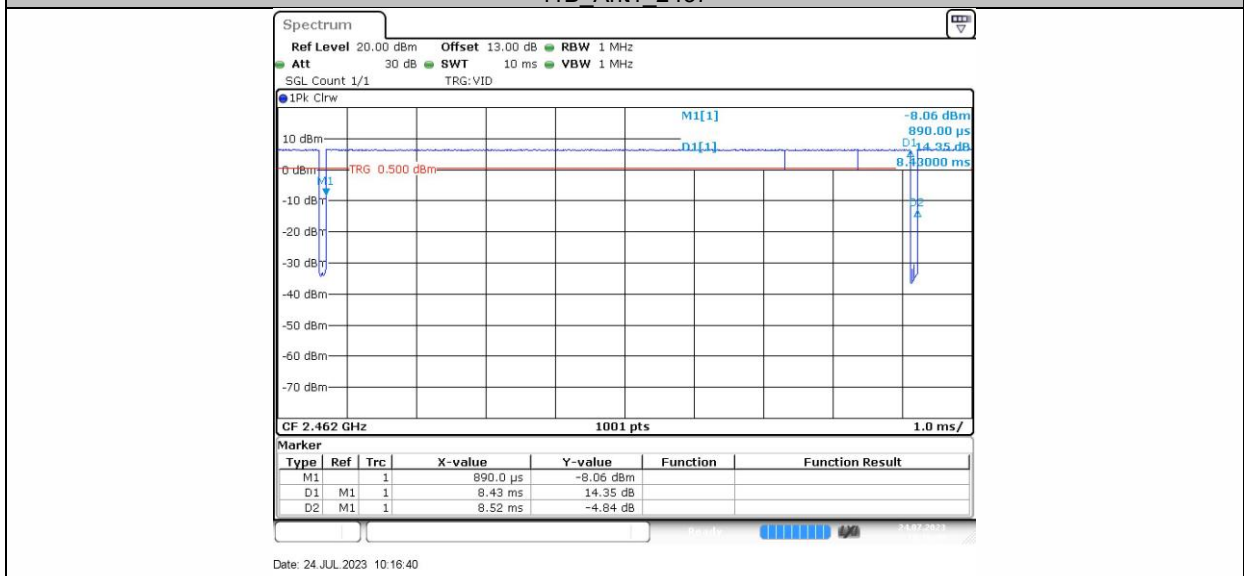



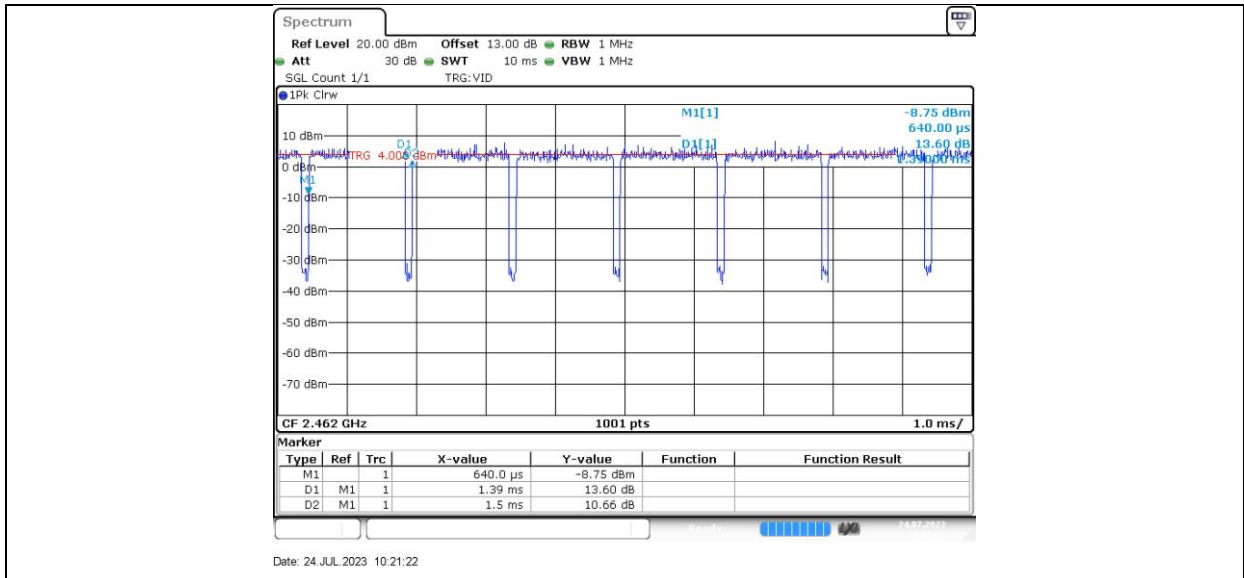

11G Ant1_2462

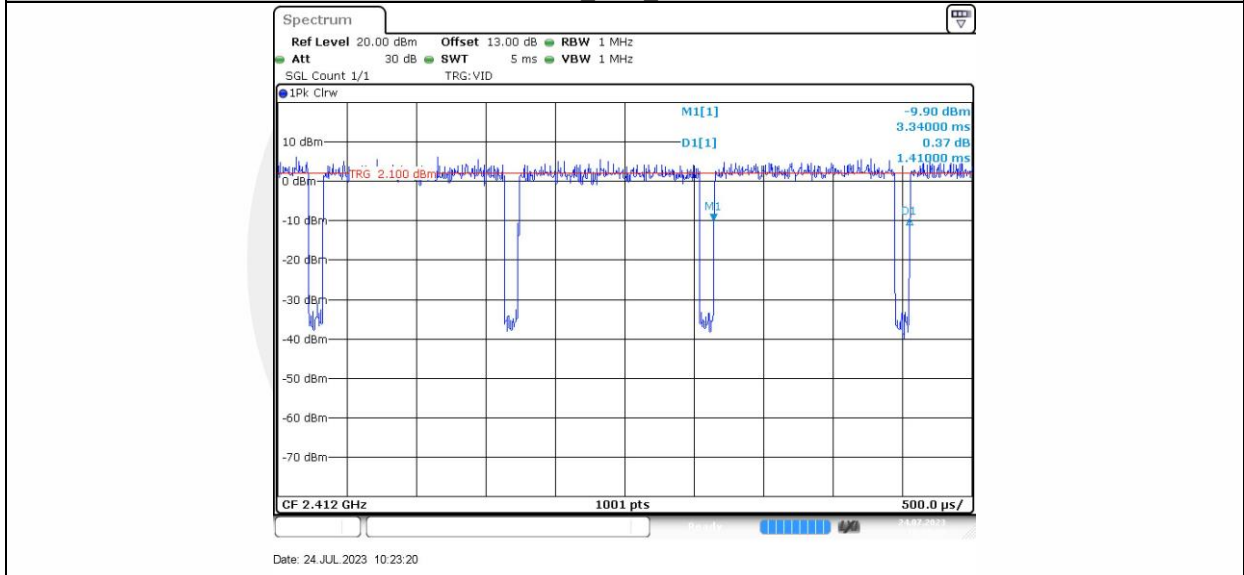

11N20SISO Ant1_2412

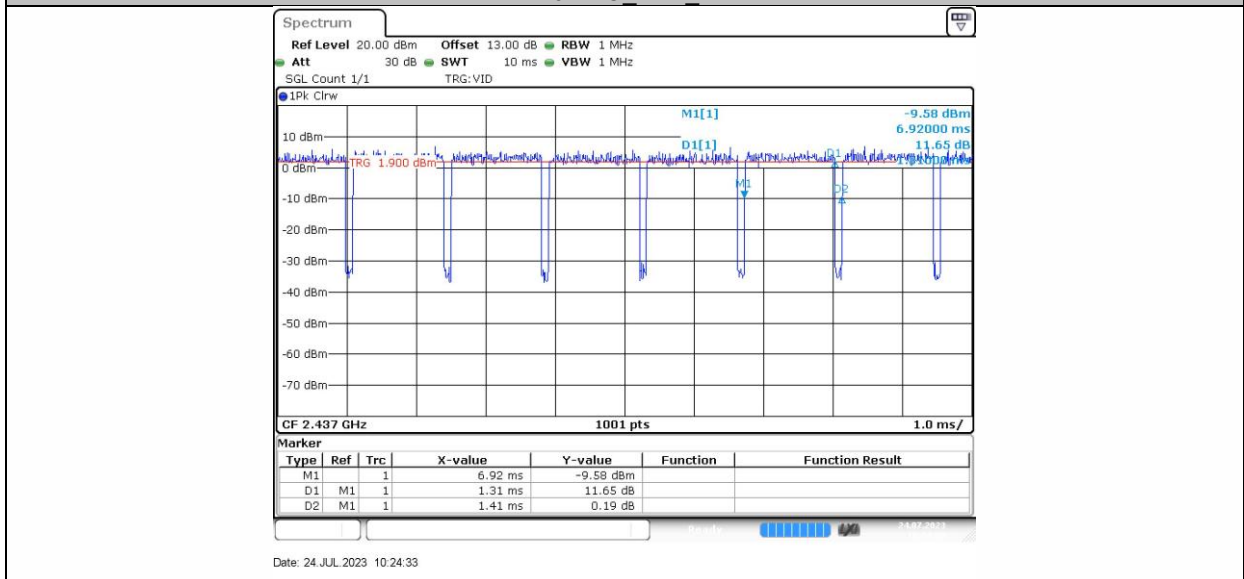

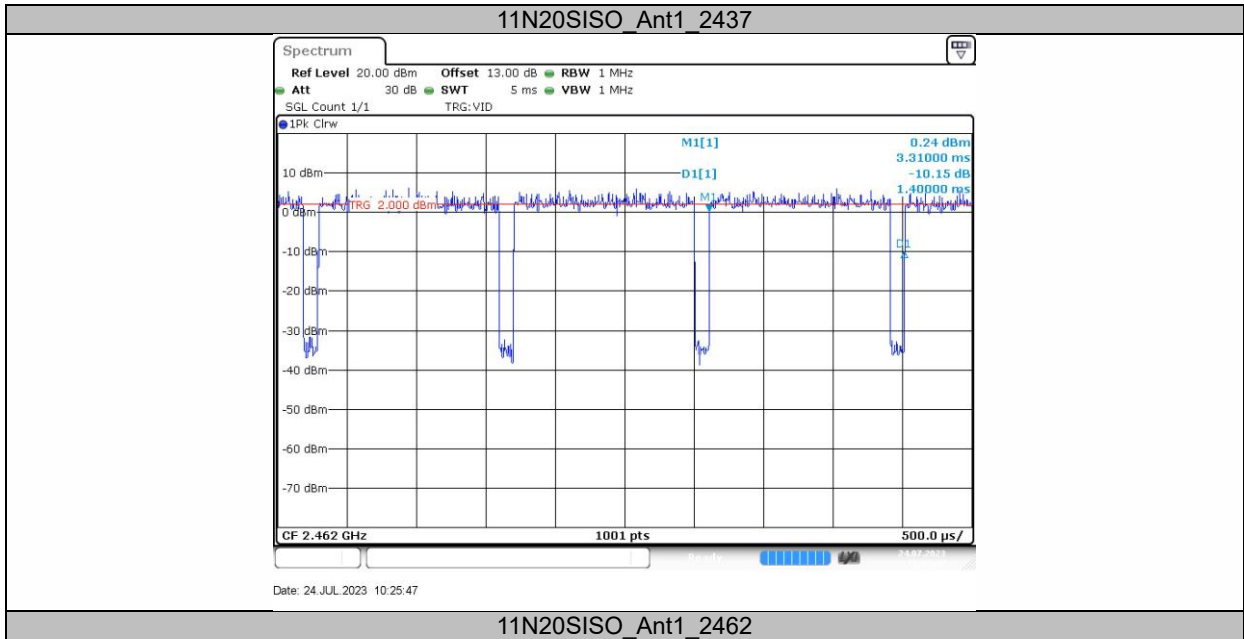

8.2 DTS 6DB BANDWIDTH

8.2.1 Applicable Standard

According to FCC Part15.247 (a)(2)

According to RSS-247 5.2(a)

According to 558074 D01 15.247 Meas Guidance v05r02 Section 8.2

According to ANSI C63.10 Section 11.8

8.2.2 Conformance Limit

The minimum -6 dB bandwidth shall be at least 500 kHz.

8.2.3 Test Configuration

Test according to clause 7.1 radio frequency test setup

8.2.4 Test Procedure

The EUT was operating in WIFI mode and controlled its channel. Printed out the test result from the spectrum by hard copy function.

The RF output of EUT was connected to the spectrum analyzer by RF cable and attenuator. The path loss was compensated to the results for each measurement.

Set to the maximum power setting and enable the EUT transmit continuously

Set RBW = 100 kHz.

Set the video bandwidth (VBW) =300 kHz.

Set Span=2 times OBW

Set Detector = Peak.

Set Trace mode = max hold.

Set Sweep = auto couple.

Allow the trace to stabilize.

Measure the maximum width of the emission that is constrained by the frequencies associated with the two outermost amplitude points (upper and lower frequencies) that are attenuated by 6 dB relative to the maximum level measured in the fundamental emission.

Measure and record the results in the test report.

8.2.5 Test Results

Temperature:	25°C
Relative Humidity:	45%
ATM Pressure:	1011 mbar
Test Engineer:	XXH

Note: N/A

TestMode	Antenna	Frequency[MHz]	DTS BW [MHz]	FL[MHz]	FH[MHz]	Limit[MHz]	Verdict
11B	Ant1	2412	9.04	2407.52	2416.56	0.5	PASS
		2437	8.56	2432.52	2441.08	0.5	PASS
		2462	9.08	2457.48	2466.56	0.5	PASS
11G	Ant1	2412	14.68	2404.92	2419.60	0.5	PASS
		2437	15.12	2429.48	2444.60	0.5	PASS
		2462	15.12	2454.48	2469.60	0.5	PASS
11N20SISO	Ant1	2412	15.08	2404.48	2419.56	0.5	PASS
		2437	15.12	2429.48	2444.60	0.5	PASS
		2462	15.12	2454.48	2469.60	0.5	PASS

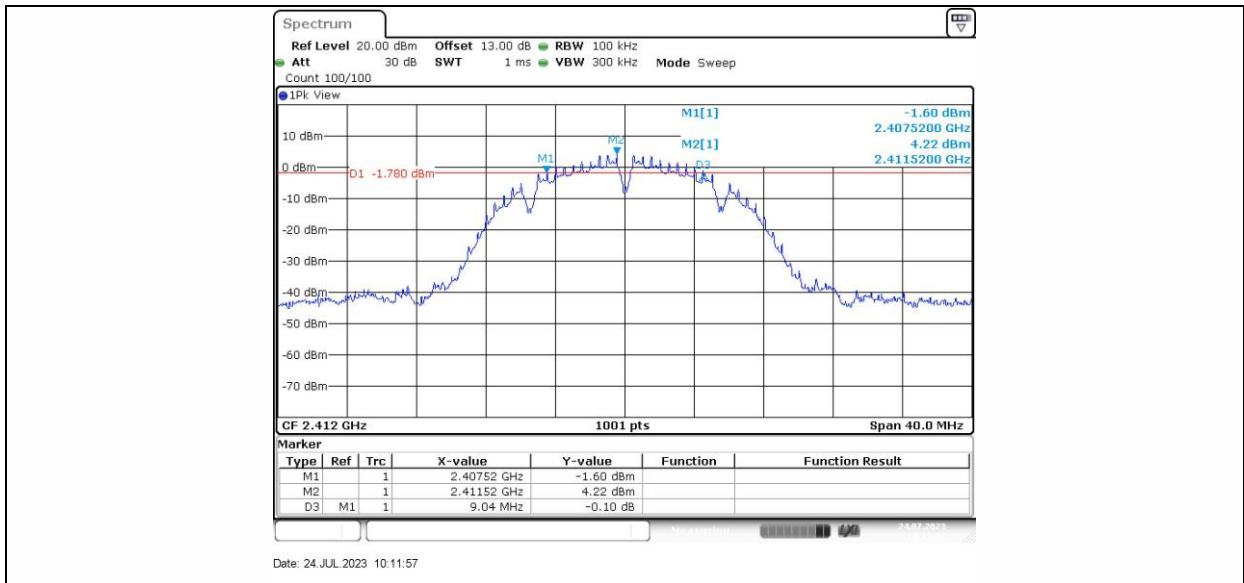

11B_Ant1_2412

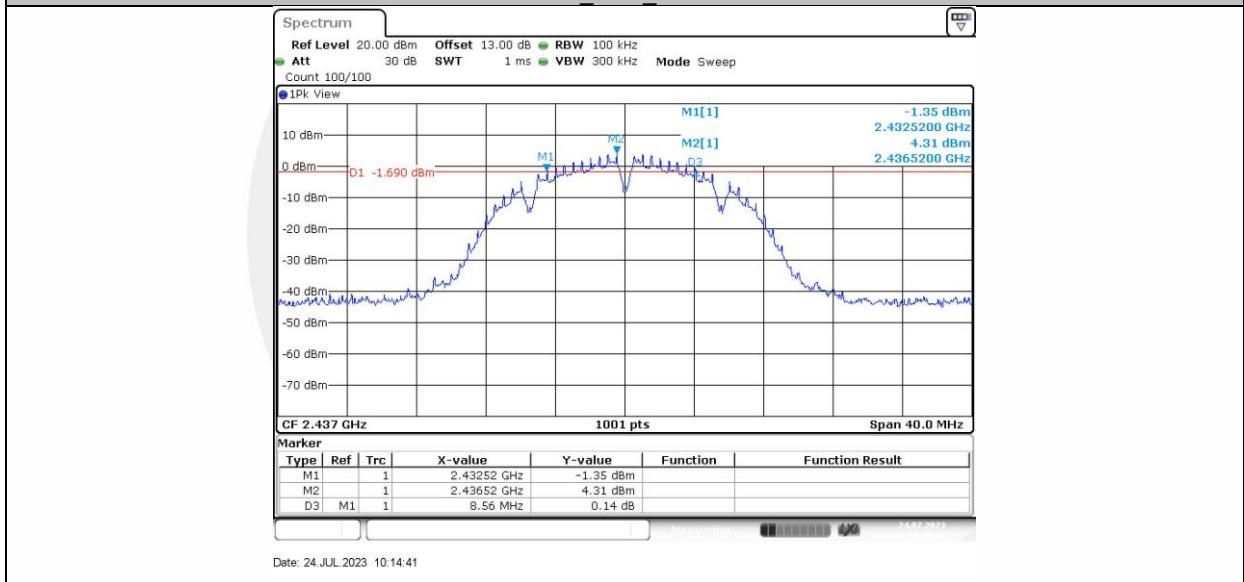

11B_Ant1_2437

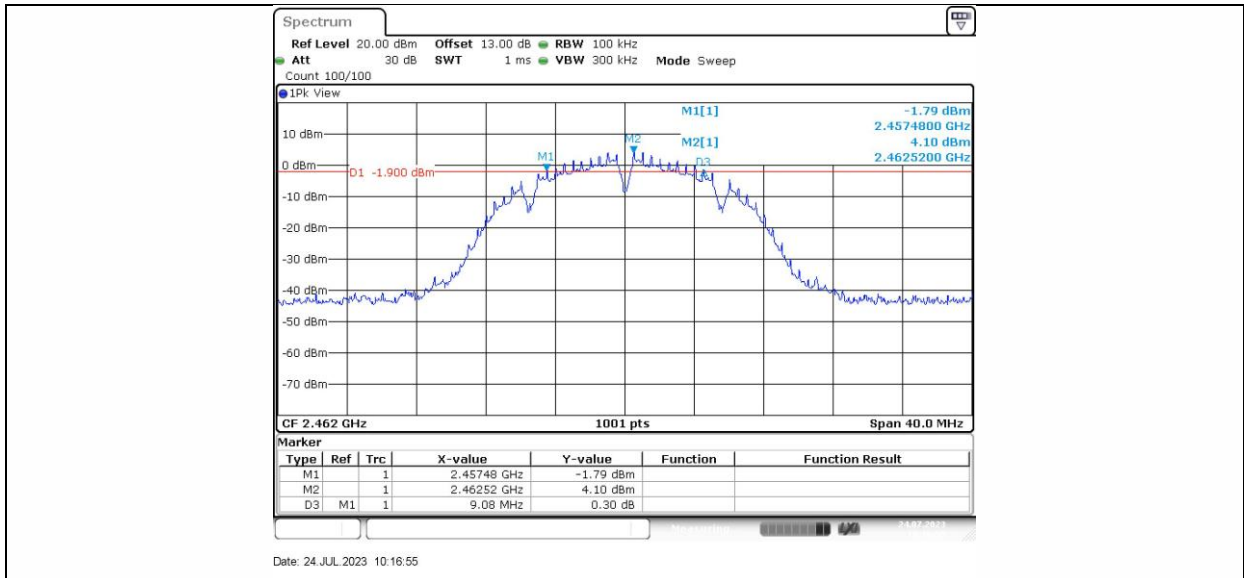

11B Ant1_2462

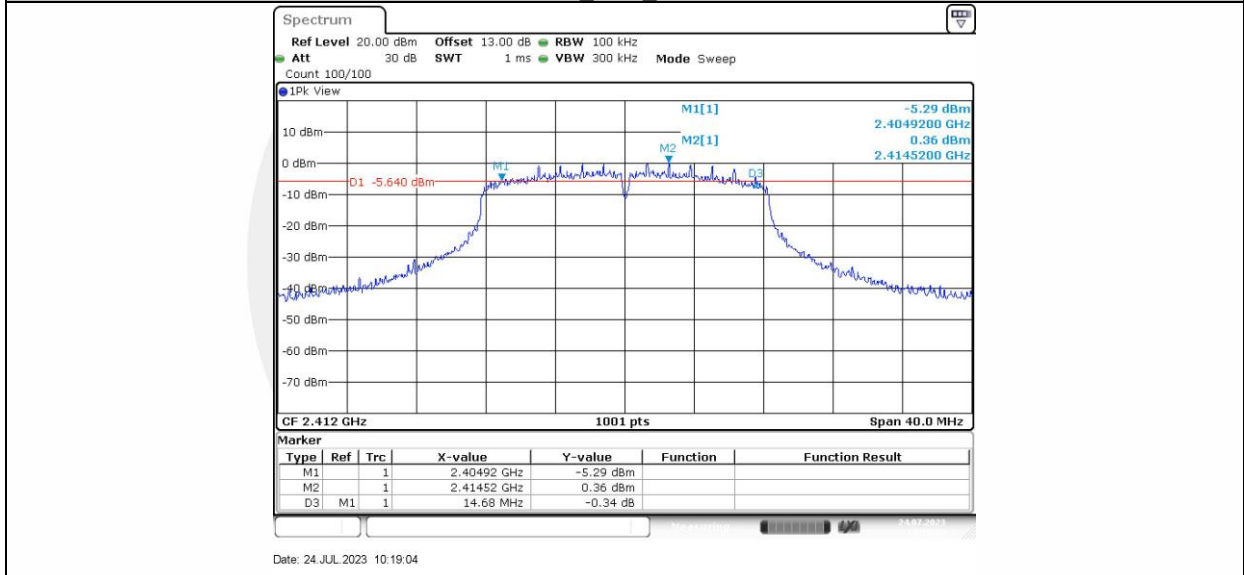

11G Ant1_2412

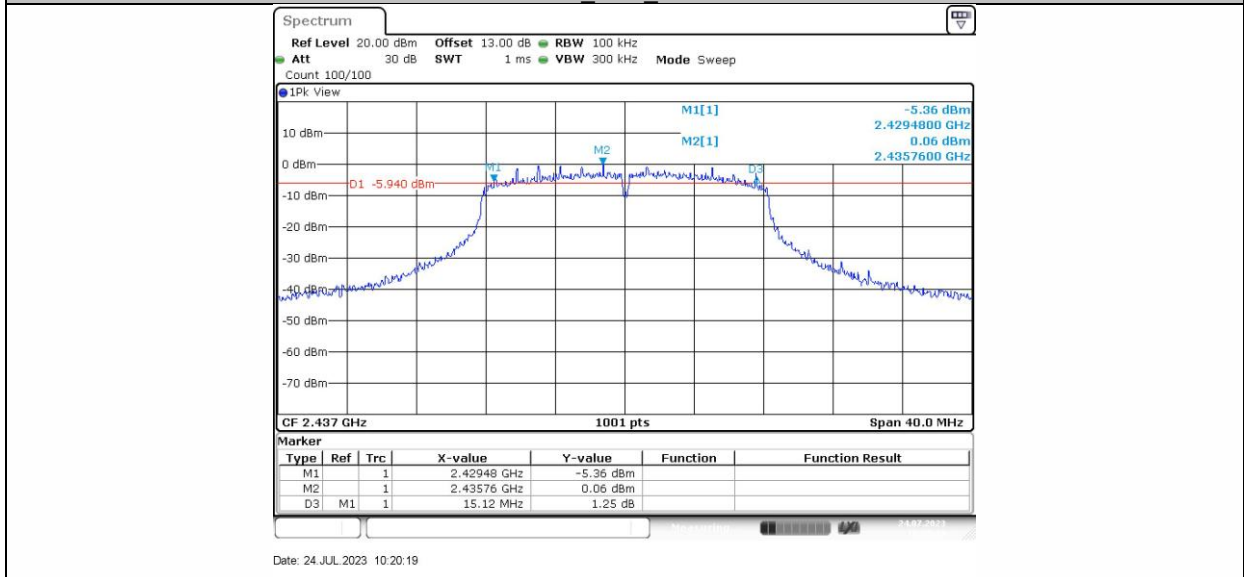

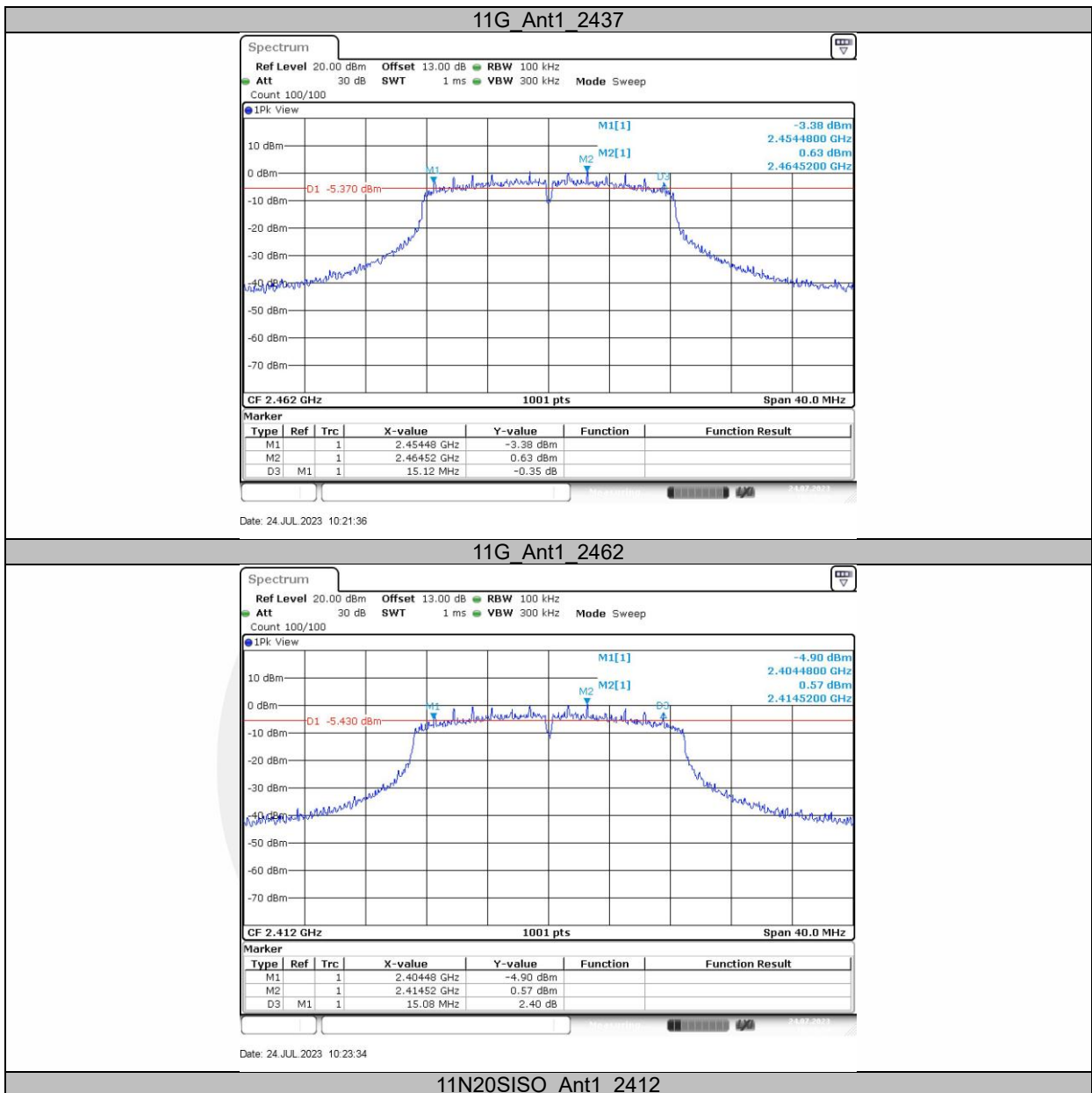

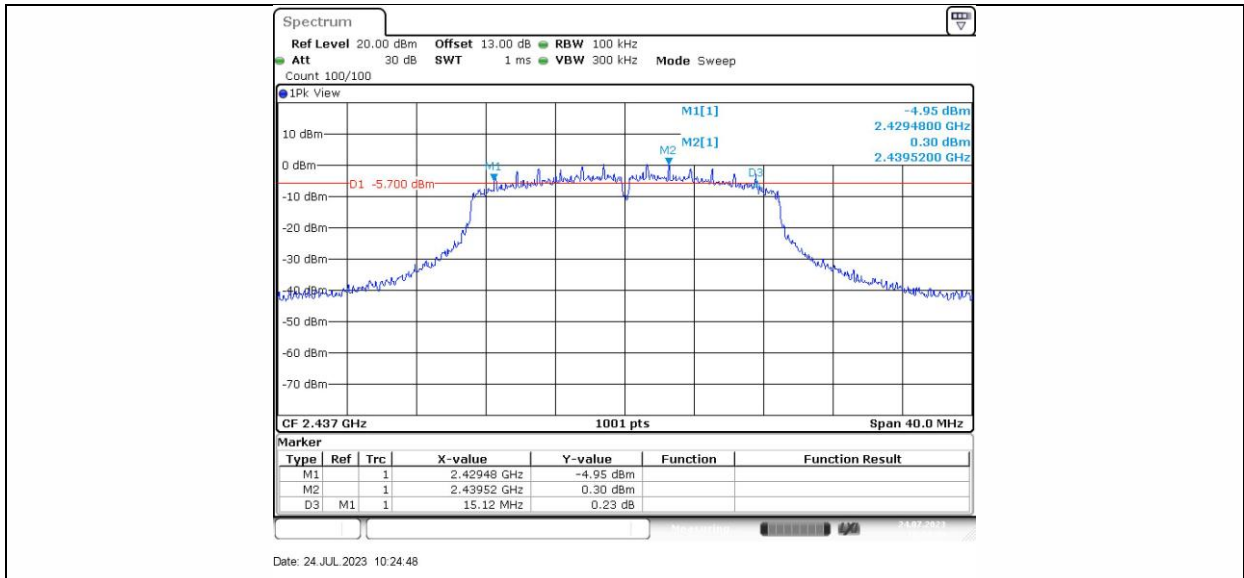

11N20SISO Ant1 2437

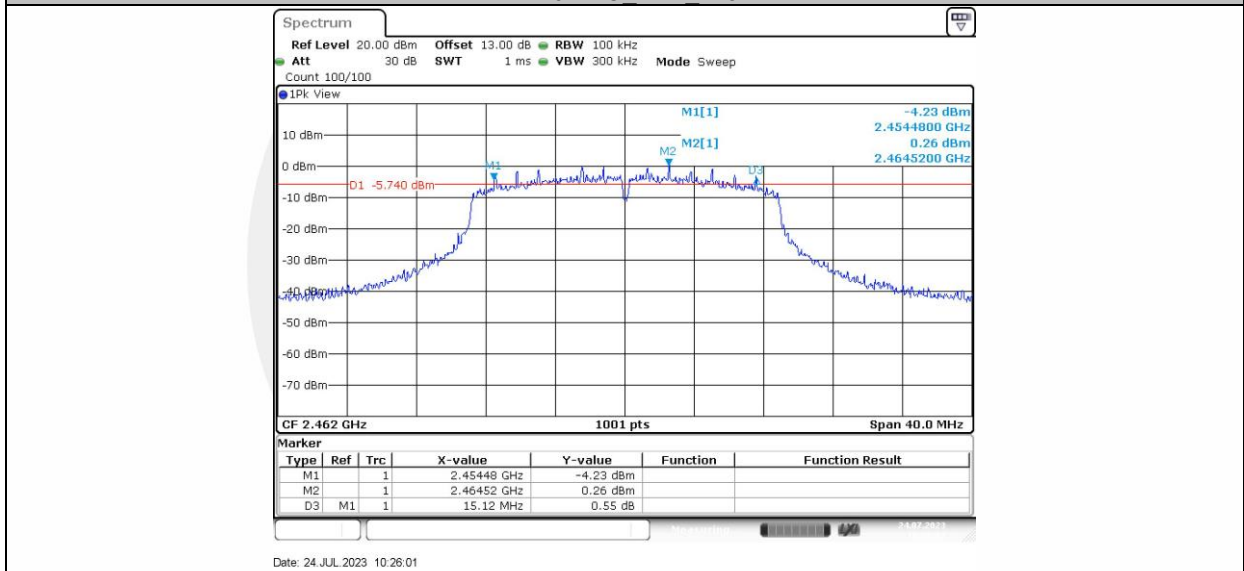

11N20SISO Ant1 2462

8.3 DTS 99% BANDWIDTH

8.3.1 Applicable Standard

According to RSS-Gen 6.7

8.3.2 Test Configuration

Test according to clause 7.1 radio frequency test setup 1

8.3.3 Test Procedure

The EUT was operating in WIFI mode and controlled its channel. Printed out the test result from the spectrum by hard copy function.

The RF output of EUT was connected to the spectrum analyzer by RF cable and attenuator. The path loss was compensated to the results for each measurement.

Set to the maximum power setting and enable the EUT transmit continuously

Set RBW = 1%-5% OBW.

Set the video bandwidth (VBW) $\geq 3 \times RBW$.

Set Span=approximately 2 to 3 times the 6 dB bandwidth.

Set Detector = Peak.

Set Trace mode = max hold.

Set Sweep = auto couple.

Allow the trace to stabilize.

Use the 99 % power bandwidth function of the instrument

Measure the maximum width of the emission.

If this value varies with different modes of operation (e.g., data rate, modulation format, etc.), repeat this test for each variation.

Measure and record the results in the test report.

8.3.4 Test Results

Temperature:	25°C
Relative Humidity:	45%
ATM Pressure:	1011 mbar
Test Engineer:	XXH

Note: N/A

TestMode	Antenna	Channel Frequency[MHz]	OCB [MHz]	FL[MHz]	FH[MHz]	Limit[MHz]	Verdict
11B	Ant1	2412	14.186	2404.9271	2419.1129	---	---
		2437	14.226	2429.9271	2444.1528	---	---
		2462	14.266	2454.8871	2469.1528	---	---
11G	Ant1	2412	16.983	2403.5285	2420.5115	---	---
		2437	16.983	2428.5285	2445.5115	---	---
		2462	17.063	2453.4885	2470.5514	---	---
11N20SISO	Ant1	2412	18.062	2402.9690	2421.0310	---	---
		2437	18.022	2428.0090	2446.0310	---	---
		2462	18.022	2453.0090	2471.0310	---	---

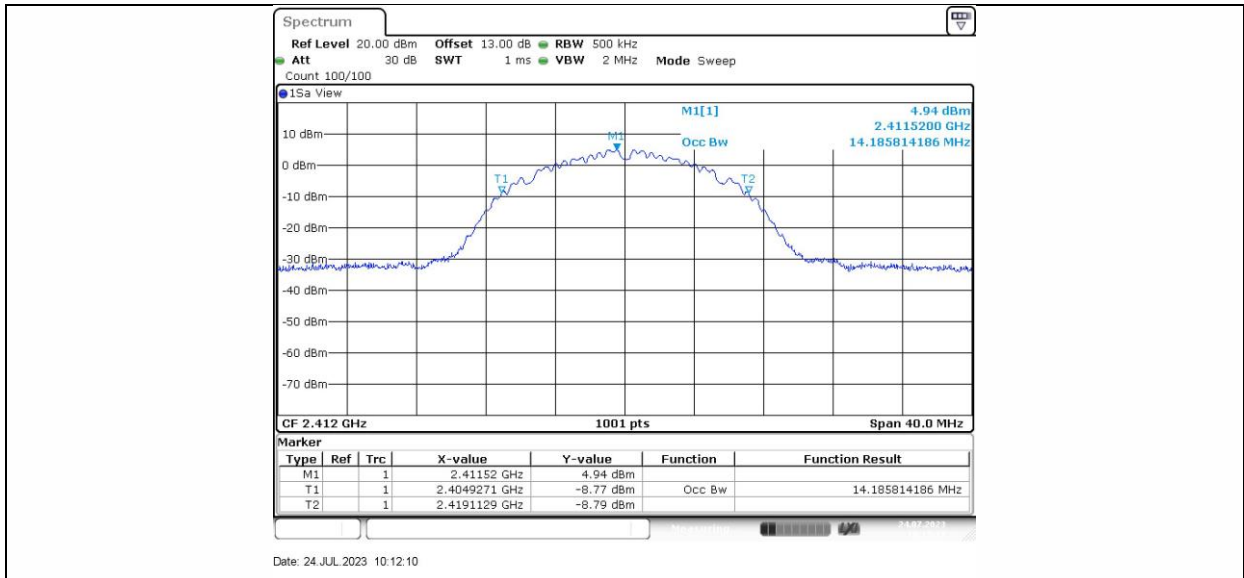

11B Ant1 2412

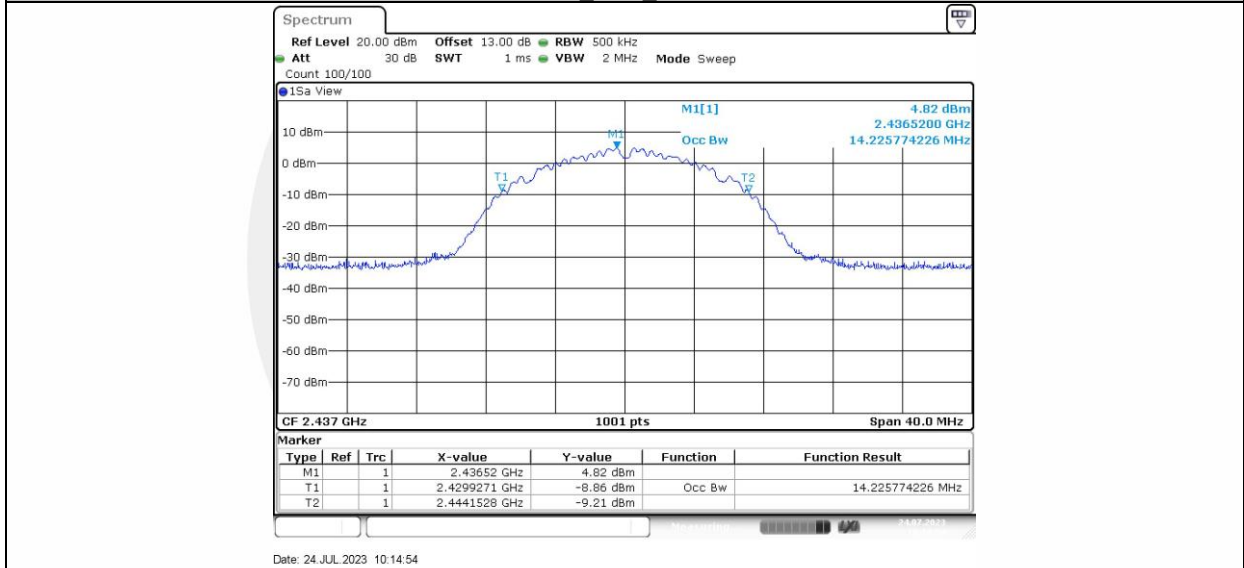

11B Ant1 2437

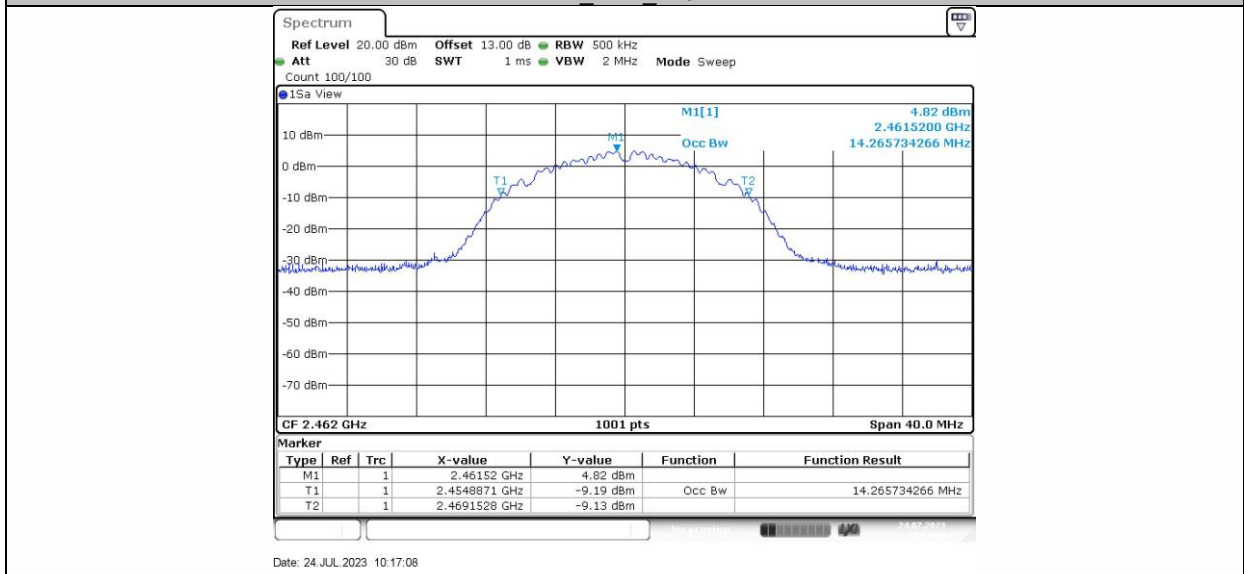

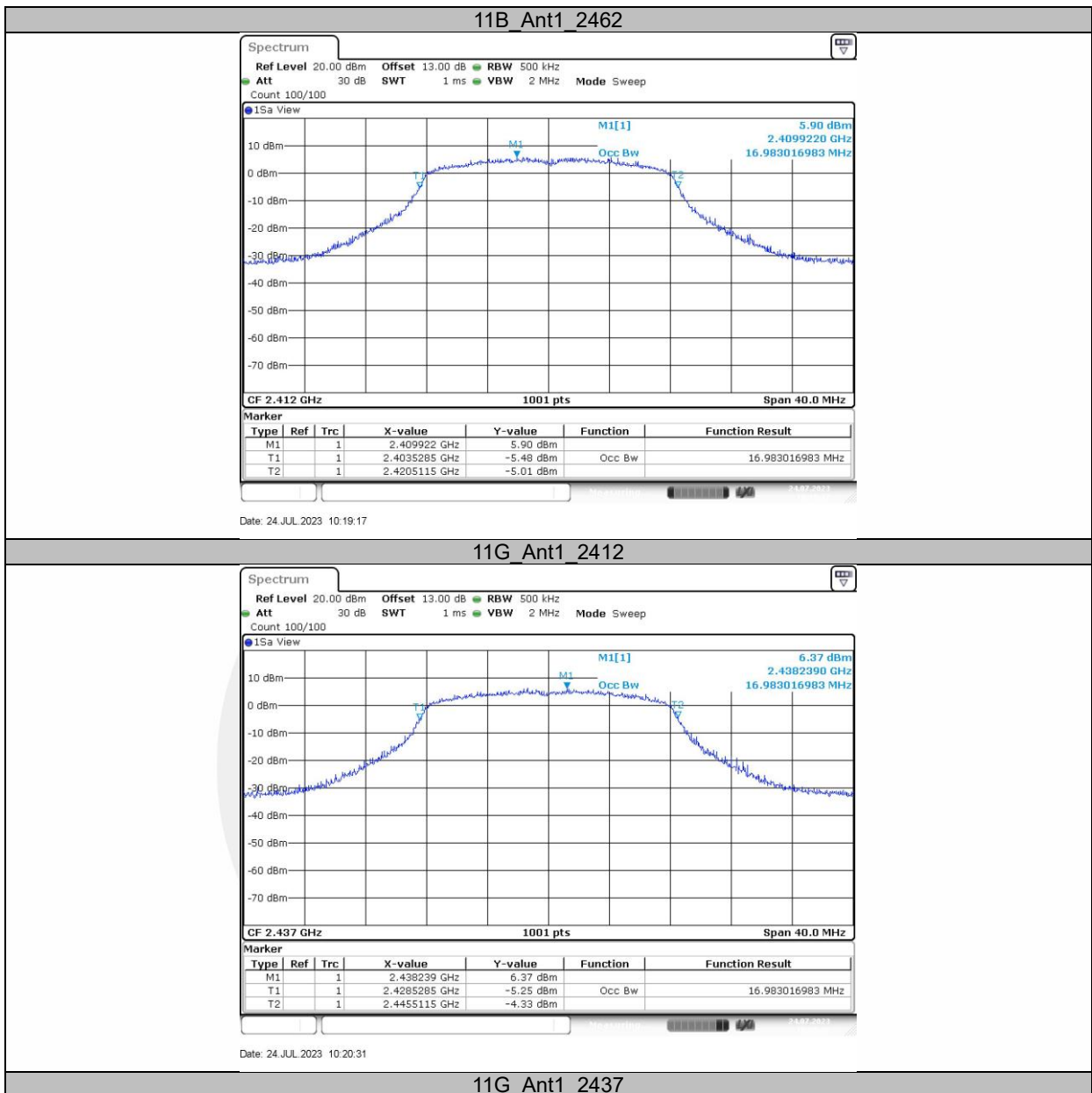

11G_Ant1_2437

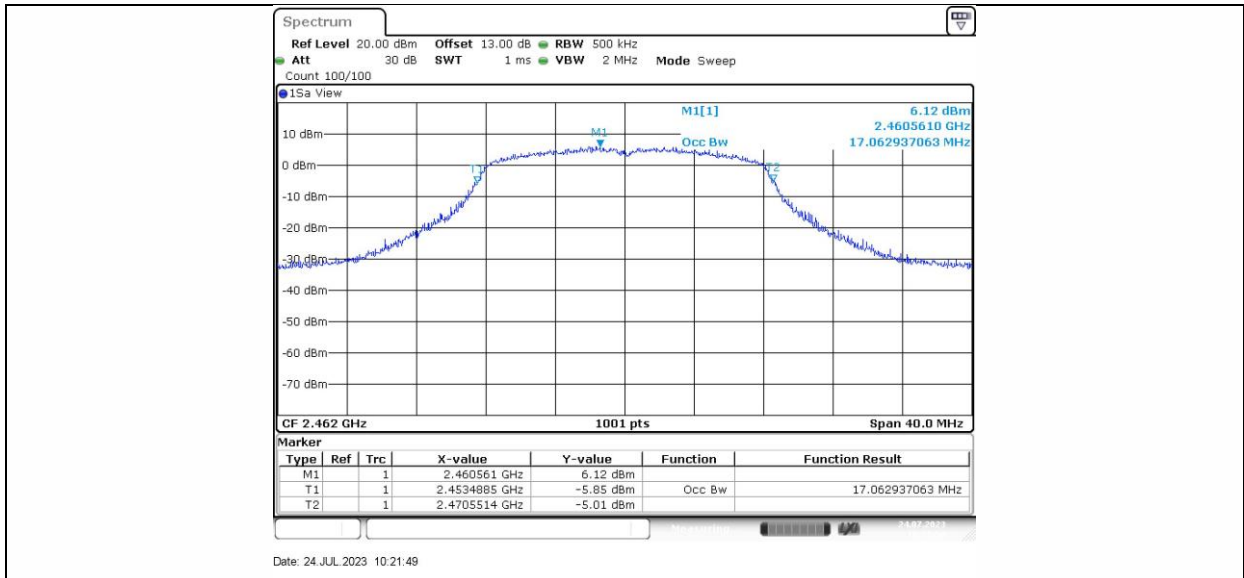

11G Ant1 2462

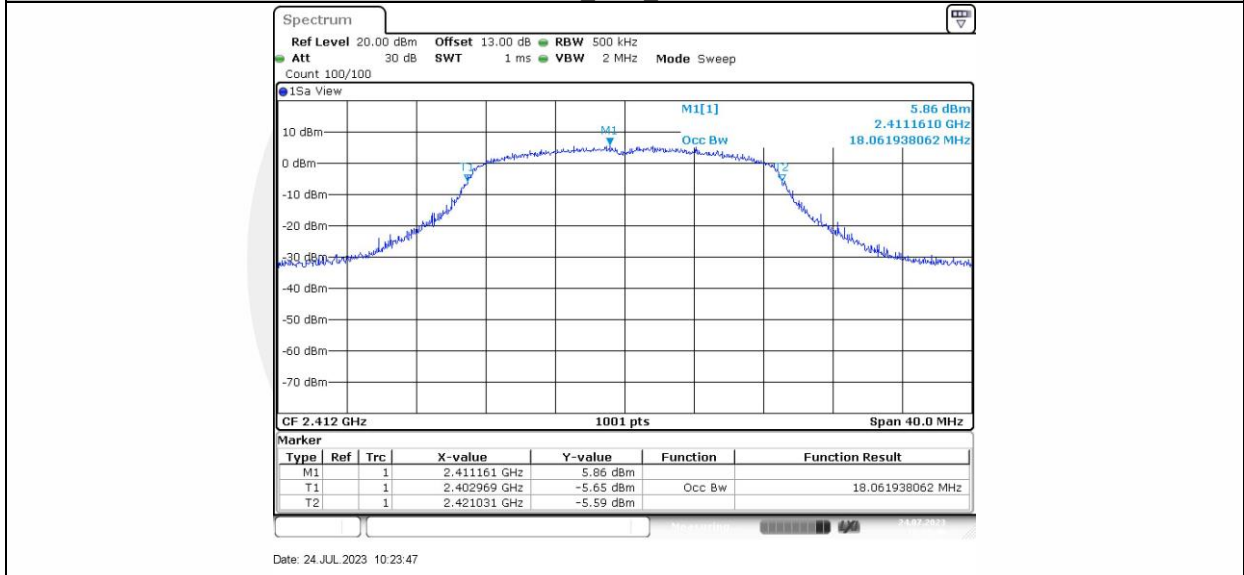

11N20SISO Ant1 2412

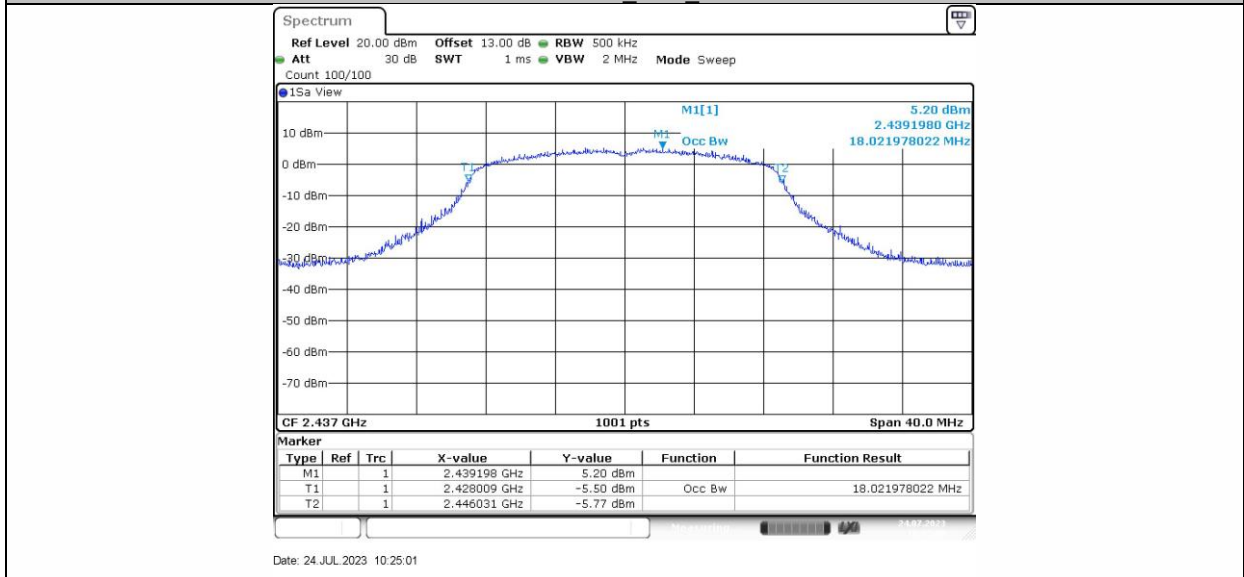



11N20SISO_Ant1_2462

8.4 MAXIMUM PEAK CONDUCTED OUTPUT POWER

8.4.1 Applicable Standard

According to FCC Part 15.247 (b)(3)
 According to RSS-247 5.4(d)
 According to RSS-Gen 6.12
 According to 558074 D01 15.247 Meas Guidance v05r02 Section 8.3.2.2
 According to ANSI C63.10 Section 11.9.2.2.4

8.4.2 Conformance Limit

The maximum conducted output power of the intentional radiator for systems using digital modulation in the 2400 - 2483.5 MHz bands shall not exceed: 1 Watt (30dBm).

8.4.3 Test Configuration

Test according to clause 7.1 radio frequency test setup

8.4.4 Test Procedure

- a) Measure the duty cycle D of the transmitter output signal.
- b) Set span to at least 1.5 times the OBW.
- c) Set RBW = 1% to 5% of the OBW, not to exceed 1 MHz.
- d) Set VBW $\geq [3 \times \text{RBW}]$.
- e) Number of points in sweep $\geq [2 \times \text{span} / \text{RBW}]$. (This gives bin-to-bin spacing $\leq \text{RBW} / 2$, so that narrowband signals are not lost between frequency bins.)
- f) Sweep time = auto.
- g) Detector = RMS (i.e., power averaging), if available. Otherwise, use the sample detector mode.
- h) Do not use sweep triggering. Allow the sweep to “free run.”
- i) Trace average at least 100 traces in power averaging (rms) mode; however, the number of traces to be averaged shall be increased above 100 as needed such that the average accurately represents the true average over the ON and OFF periods of the transmitter.
- j) Compute power by integrating the spectrum across the OBW of the signal using the instrument’s band power measurement function with band limits set equal to the OBW band edges. If the instrument does not have a band power function, then sum the spectrum levels (in power units) at intervals equal to the RBW extending across the entire OBW of the spectrum.
- k) Add $[10 \log (1 / D)]$, where D is the duty cycle, to the measured power to compute the average power during the actual transmission times (because the measurement represents an average over both the ON and OFF times of the transmission). For example, add $[10 \log (1/0.25)] = 6 \text{ dB}$ if the duty cycle is 25%.

■ According to FCC Part 15.247(b)(4):

Conducted output power limit specified in paragraph (b) of this section is based on the use of antennas with directional gains that do not exceed 6 dBi. If transmitting antennas of directional gain greater than 6 dBi are used, the conducted output power from the intentional radiator shall be reduced below the stated values in paragraphs (b)(3) of this section, as appropriate, by the amount in dB that the directional gain of the antenna exceeds 6 dBi.

Note: If antenna Gain exceeds 6 dBi, then Output power Limit = $30 - (\text{Gain} - 6)$

8.4.5 Test Results

Temperature:	25 °C
Relative Humidity:	45%
ATM Pressure:	1011 mbar
Test Engineer:	XXH

Note: N/A

Test Mode	Antenna	Frequency [MHz]	Result [dBm]	Limit [dBm]	Gain [dBi]	EIRP [dBm]	EIRP Limit [dBm]	Verdict
11B	Ant1	2412	12.66	≤30.00	5.20	17.86	≤36.00	PASS
		2437	12.53	≤30.00	5.20	17.73	≤36.00	PASS
		2462	12.54	≤30.00	5.20	17.74	≤36.00	PASS
11G	Ant1	2412	11.26	≤30.00	5.20	16.46	≤36.00	PASS
		2437	11.35	≤30.00	5.20	16.55	≤36.00	PASS
		2462	11.42	≤30.00	5.20	16.62	≤36.00	PASS
11N20SIS O	Ant1	2412	10.78	≤30.00	5.20	15.98	≤36.00	PASS
		2437	10.77	≤30.00	5.20	15.97	≤36.00	PASS
		2462	10.84	≤30.00	5.20	16.04	≤36.00	PASS



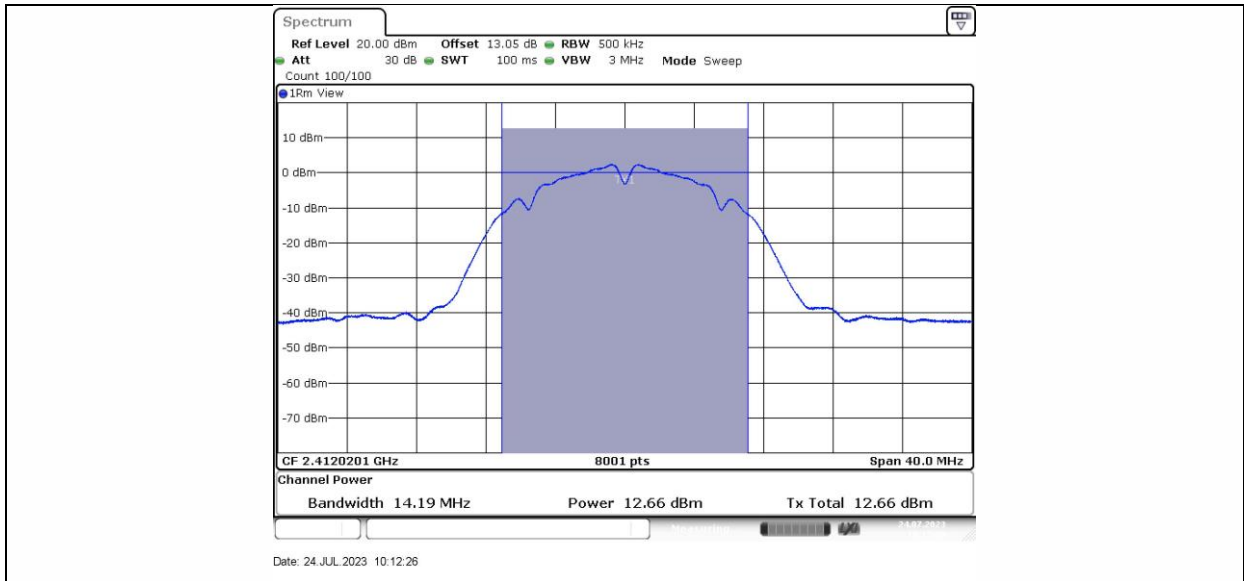

11B_Ant1_2412

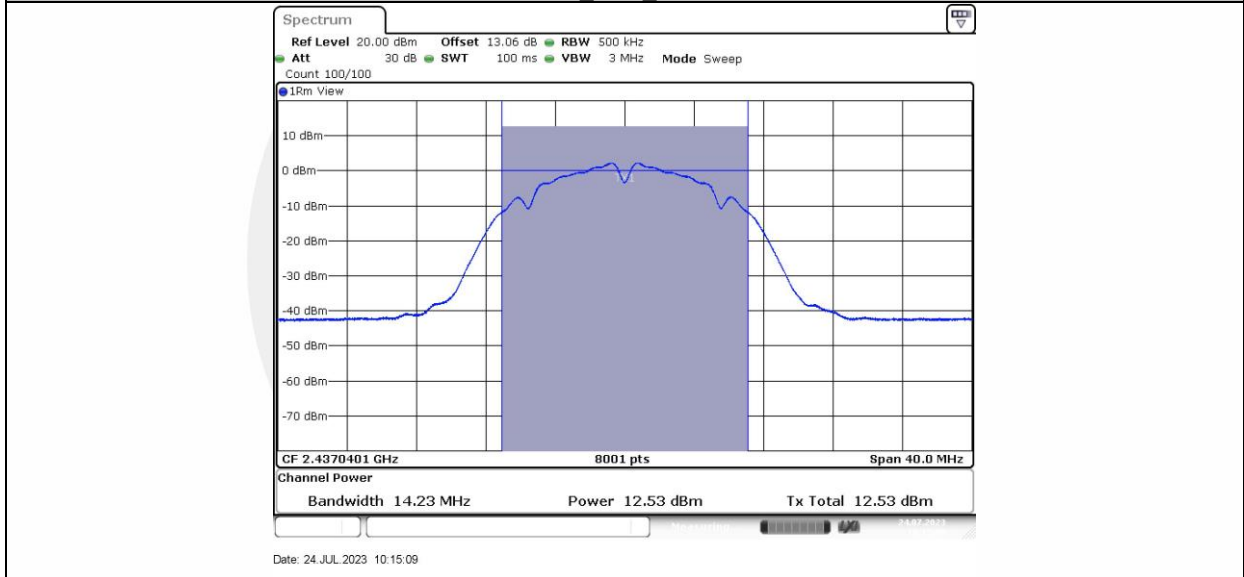

11B_Ant1_2437

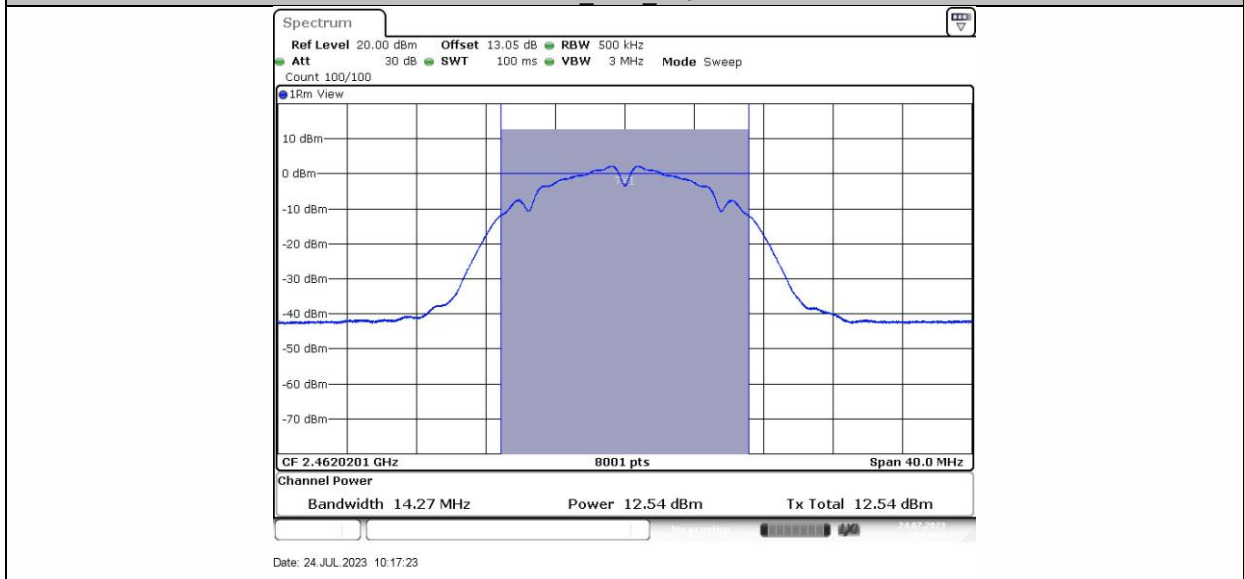

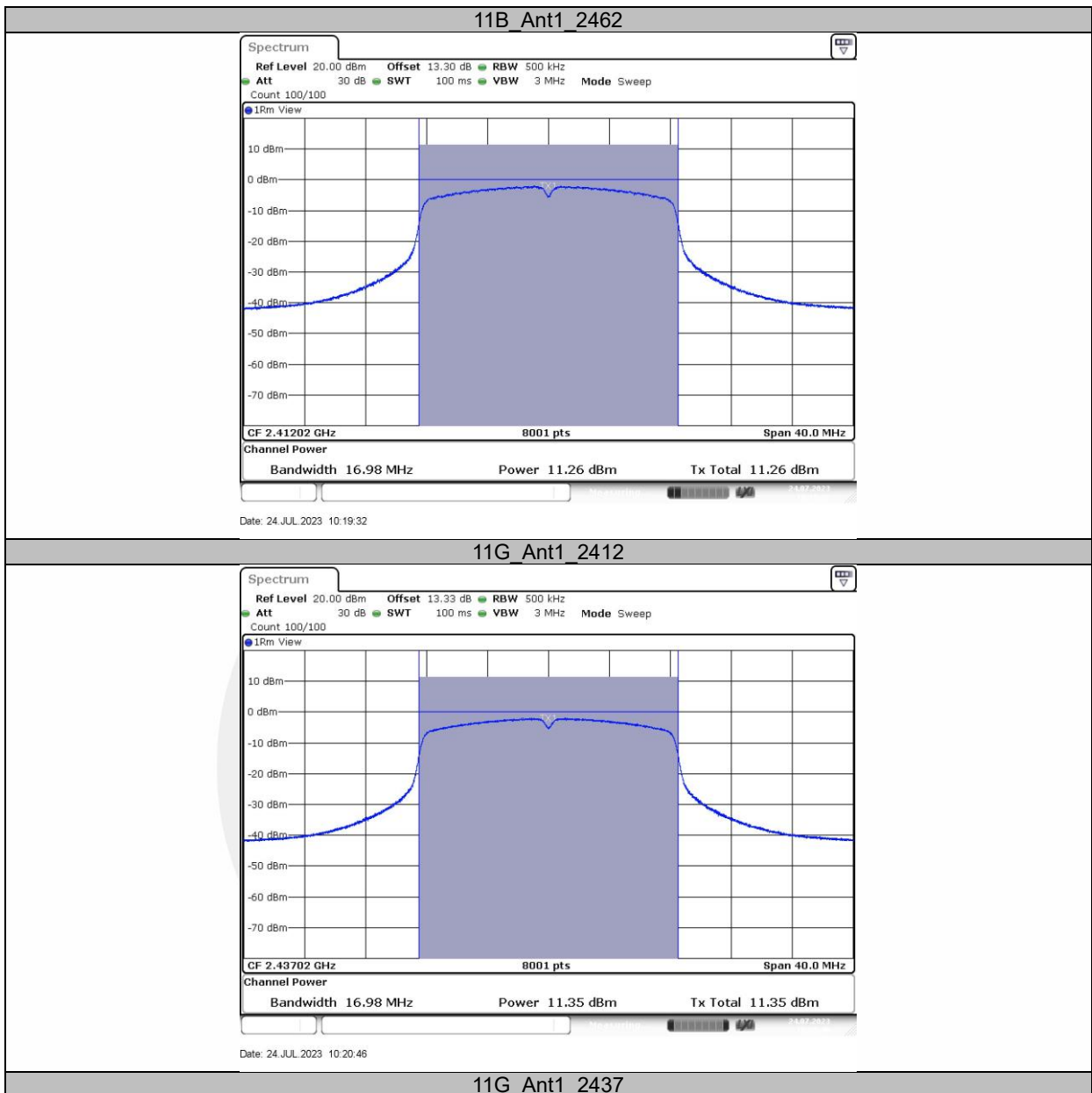

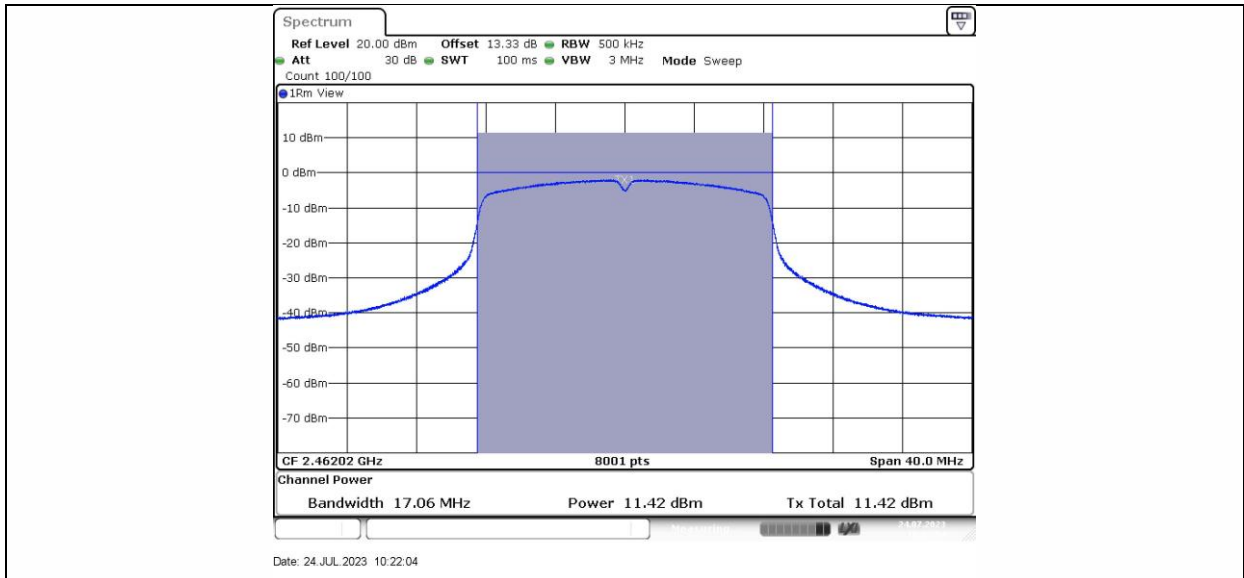

11G Ant1_2462

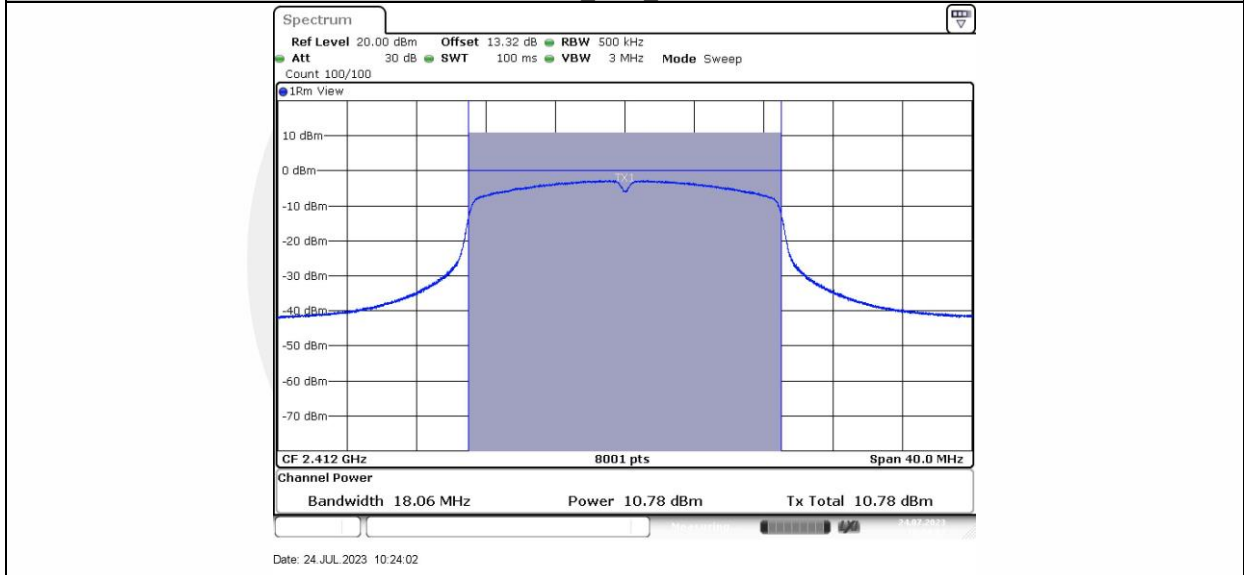

11N20SISO Ant1_2412

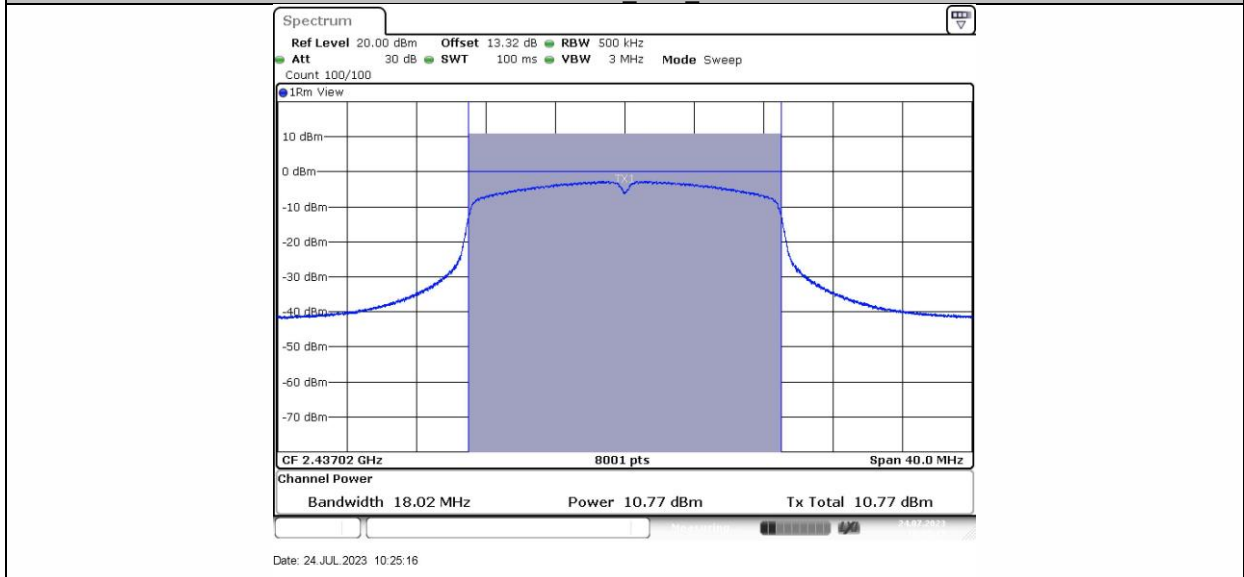

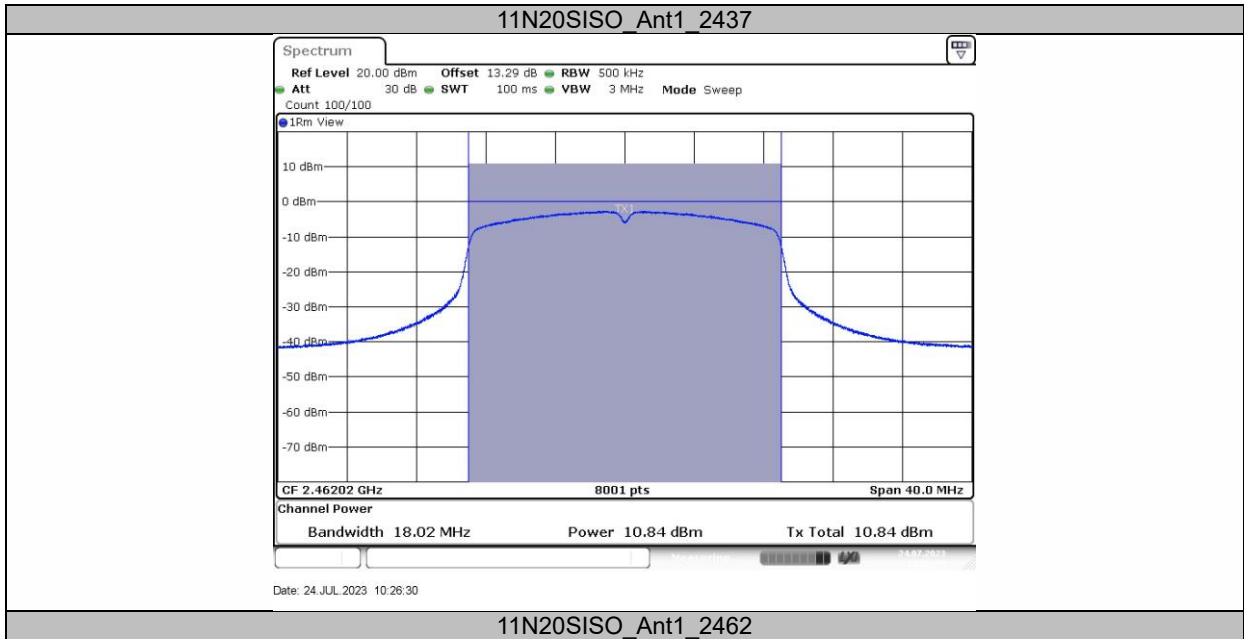

8.5 MAXIMUM POWER SPECTRAL DENSITY

8.5.1 Applicable Standard

According to FCC Part15.247(e)
 According to RSS-247 5.2(b)
 According to RSS-Gen 6.12
 According to 558074 D01 15.247 Meas Guidance v05r02 Section 8.4
 According to ANSI C63.10 Section 11.10.5

8.5.2 Conformance Limit

The transmitter power spectral density conducted from the transmitter to the antenna shall not be greater than 8 dBm in any 3 kHz band during any time interval of continuous transmission. This power spectral density shall be determined in accordance with the provisions of section 5.4(d), (i.e. the power spectral density shall be determined using the same method as is used to determine the conducted output power).

8.5.3 Test Configuration

Test according to clause 7.1 radio frequency test setup

8.5.4 Test Procedure

- a) Measure the duty cycle (D) of the transmitter output signal
- b) Set instrument center frequency to DTS channel center frequency.
- c) Set span to at least 1.5 times the OBW.
- d) Set RBW to: $3 \text{ kHz} \leq \text{RBW} \leq 100 \text{ kHz}$.
- e) Set VBW $\geq [3 \times \text{RBW}]$.
- f) Detector = power averaging (rms) or sample detector (when rms not available).
- g) Ensure that the number of measurement points in the sweep $\geq [2 \times \text{span} / \text{RBW}]$.
- h) Sweep time = auto couple.
- i) Do not use sweep triggering; allow sweep to "free run."
- j) Employ trace averaging (rms) mode over a minimum of 100 traces.
- k) Use the peak marker function to determine the maximum amplitude level.
- l) Add $[10 \log (1 / D)]$, where D is the duty cycle measured in step a), to the measured PSD to compute the average PSD during the actual transmission time.
- m) If measured value exceeds requirement specified by regulatory agency, then reduce RBW (but no less than 3 kHz) and repeat (note that this may require zooming in on the emission of interest and reducing the span to meet the minimum measurement point requirement as the RBW is reduced).

8.5.5 Test Results

Temperature:	25 °C
Relative Humidity:	45%
ATM Pressure:	1011 mbar
Test Engineer:	XXH

Note: N/A

TestMode	Antenna	Frequency[MHz]	Result[dBm/3-100kHz]	Limit[dBm/3kHz]	Verdict
11B	Ant1	2412	-18.77	≤8.00	PASS
		2437	-18.96	≤8.00	PASS
		2462	-18.89	≤8.00	PASS
11G	Ant1	2412	-22.35	≤8.00	PASS
		2437	-22.02	≤8.00	PASS
		2462	-22.48	≤8.00	PASS
11N20SISO	Ant1	2412	-23.4	≤8.00	PASS
		2437	-23.18	≤8.00	PASS
		2462	-23.19	≤8.00	PASS



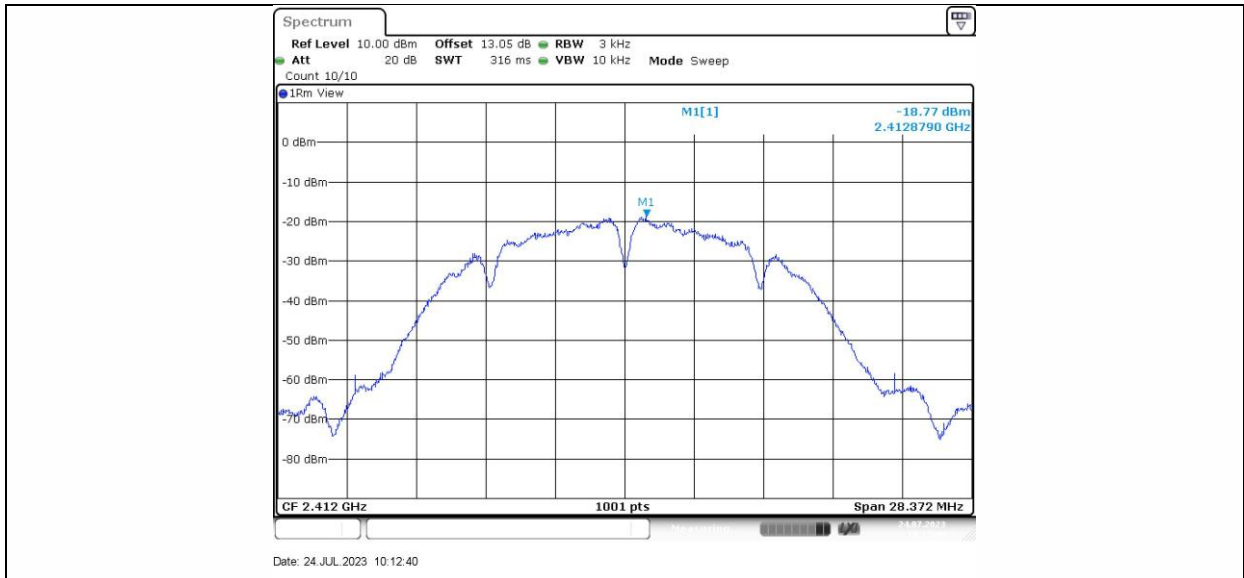

11B_Ant1_2412

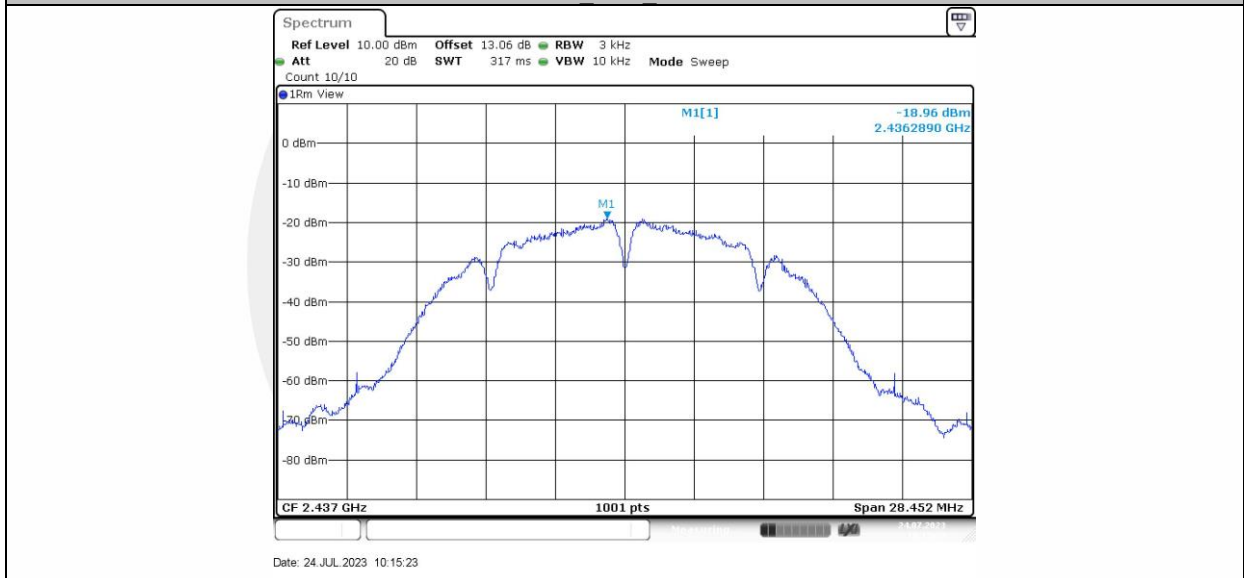

11B_Ant1_2437

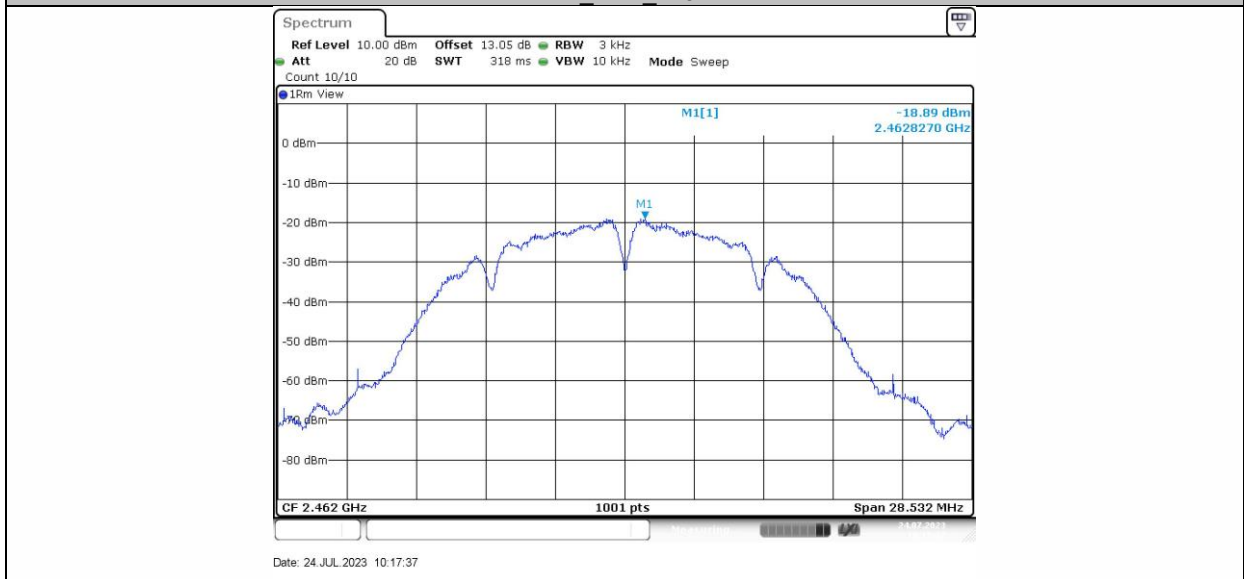

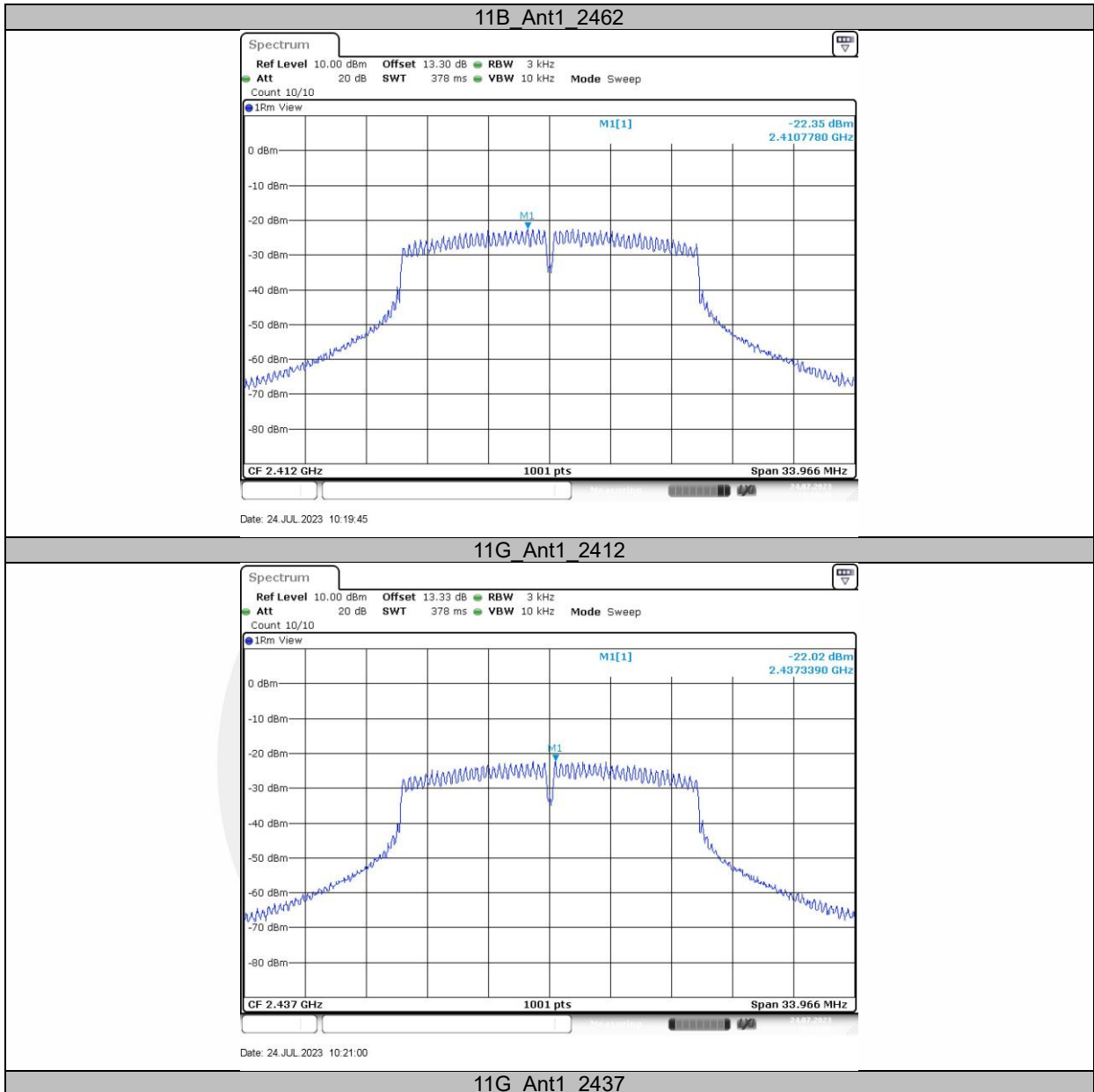

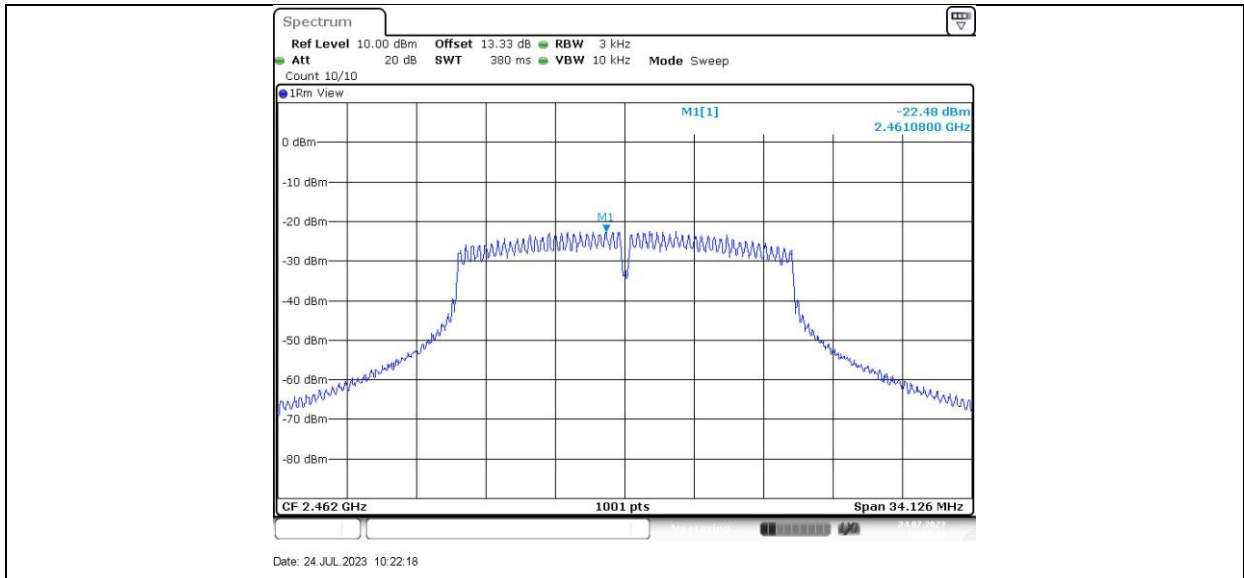

11G Ant1_2462

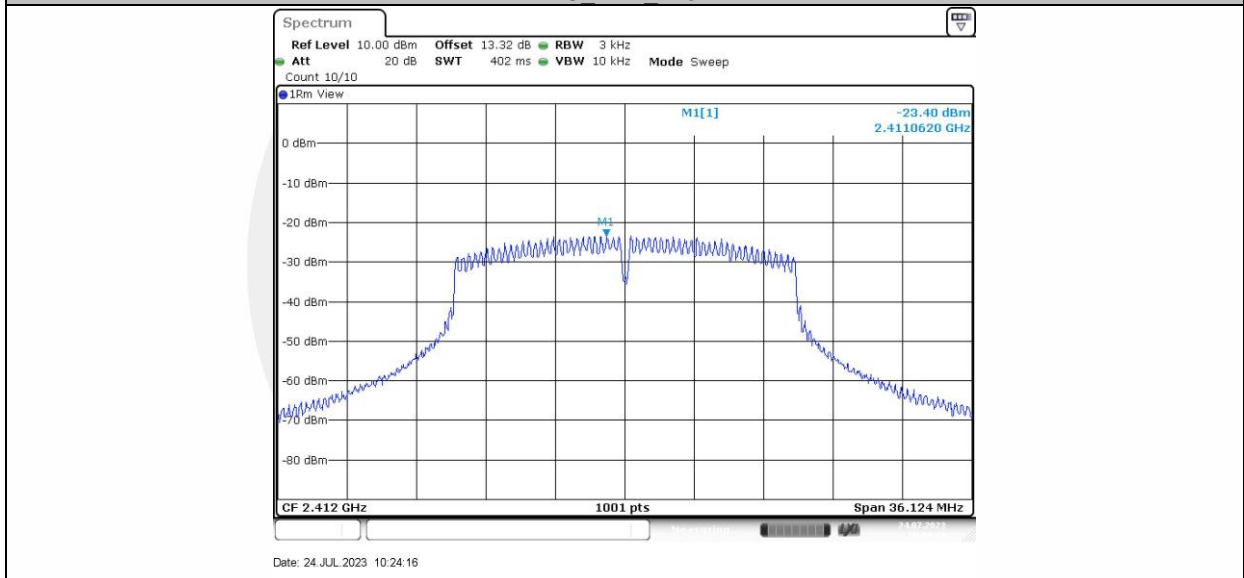

11N20SISO Ant1_2412

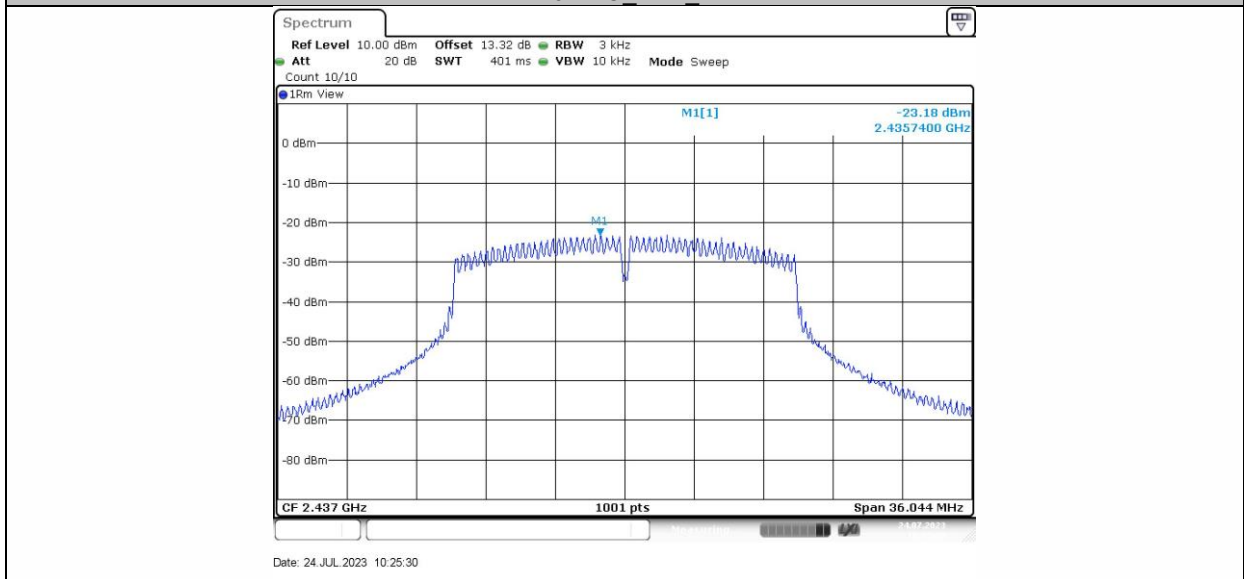



8.6 UNWANTED EMISSIONS IN NON-RESTRICTED FREQUENCY BANDS

8.6.1 Applicable Standard

According to FCC Part 15.247(d)

According to RSS-247 5.5

According to 558074 D01 15.247 Meas Guidance v05r02 Section 8.5

According to ANSI C63.10 Section 11.11

8.6.2 Conformance Limit

According to FCC Part 15.247(d):

In any 100 kHz bandwidth outside the frequency band in which the spread spectrum or digitally modulated device is operating, the RF power that is produced shall be at least 20 dB below that in the 100 kHz bandwidth within the band that contains the highest level of the desired power, based on either an RF conducted or a radiated measurement, provided that the transmitter demonstrates compliance with the peak conducted power limits. If the transmitter complies with the conducted power limits based on the use of root-mean-square averaging over a time interval, as permitted under section 5.4(d), the attenuation required shall be 30 dB instead of 20 dB. Attenuation below the general field strength limits specified in RSS-Gen is not required.

8.6.3 Test Configuration

Test according to clause 7.1 radio frequency test setup

8.6.4 Test Procedure

The transmitter output (antenna port) was connected to the spectrum analyzer

■ Reference level measurement

Establish a reference level by using the following procedure:

Set instrument center frequency to DTS channel center frequency.

Set the span to ≥ 1.5 times the DTS bandwidth.

Set the RBW = 100 kHz.

Set the VBW $\geq 3 \times$ RBW.

Set Detector = peak.

Set Sweep time = auto couple.

Set Trace mode = max hold.

Allow trace to fully stabilize.

Use the peak marker function to determine the maximum PSD level.

Note that the channel found to contain the maximum PSD level can be used to establish the reference level.

■ Band-edge measurement

Use the following spectrum analyzer settings:

Span = wide enough to capture the peak level of the emission operating on the channel closest to the band-edge, as well as any modulation products which fall outside of the authorized band of operation

Set RBW $\geq 1\%$ of the span=100kHz Set VBW $\geq 3 \times$ RBW

Set Sweep = auto Set Detector function = peak Set Trace = max hold

Allow the trace to stabilize. Set the marker on the emission at the bandedge, or on the highest modulation product outside of the band, if this level is greater than that at the bandedge. Enable the marker-delta function, then use the marker-to-peak function to move the marker to the peak of the in-band emission. The marker-delta value now displayed must comply with the limit specified in this Section.

■ Emission level measurement

Set the center frequency and span to encompass frequency range to be measured.

Set the RBW = 100 kHz.

Set the VBW = 300 kHz.

Set Detector = peak

Sweep time = auto couple.

Trace mode = max hold.

Allow trace to fully stabilize.

Use the peak marker function to determine the maximum amplitude level.

Ensure that the amplitude of all unwanted emissions outside of the authorized frequency band (excluding restricted frequency bands) are attenuated by at least the minimum requirements . Report the three highest emissions relative to the limit.

8.6.5 Test Results

Temperature:	25 °C
Relative Humidity:	45%
ATM Pressure:	1011 mbar
Test Engineer:	XXH

Note: N/A

Reference level measurement

TestMode	Antenna	Freq(MHz)	Max.Point[MHz]	Result[dBm]
11B	Ant1	2412	2411.02	4.28
		2437	2438.02	4.07
		2462	2461.51	3.76

Band-edge measurement

Test Mode	Antenna	ChName	Frequency [MHz]	RefLevel [dBm]	Result [dBm]	Limit [dBm]	Verdict
11B	Ant1	Low	2412	4.28	-36.53	≤-25.72	PASS
		High	2462	3.76	-37.43	≤-26.24	PASS

Emission level measurement

TestMode	Antenna	Frequency[MHz]	FreqRange [Mhz]	RefLevel [dBm]	Result [dBm]	Limit [dBm]	Verdict
11B	Ant1	2412	30~1000	4.28	-46.92	≤-25.72	PASS
			1000~26500	4.28	-42.54	≤-25.72	PASS
		2437	30~1000	4.07	-46.61	≤-25.93	PASS
			1000~26500	4.07	-42.67	≤-25.93	PASS
		2462	30~1000	3.76	-46.71	≤-26.24	PASS
			1000~26500	3.76	-42.36	≤-26.24	PASS

Reference level measurement

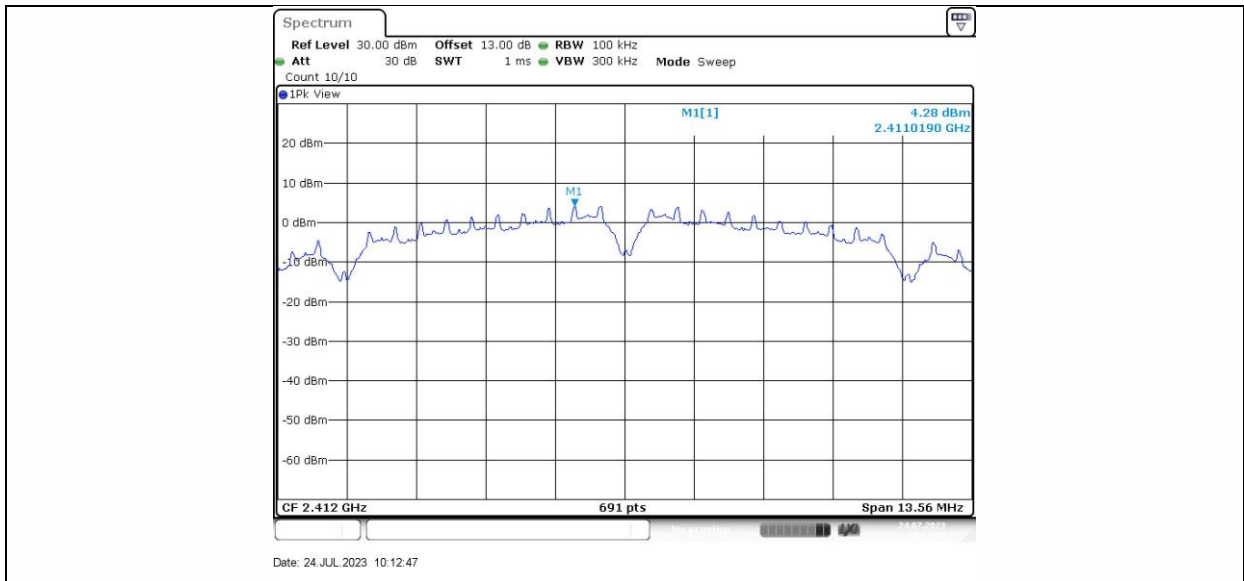

11B_Ant1_2412

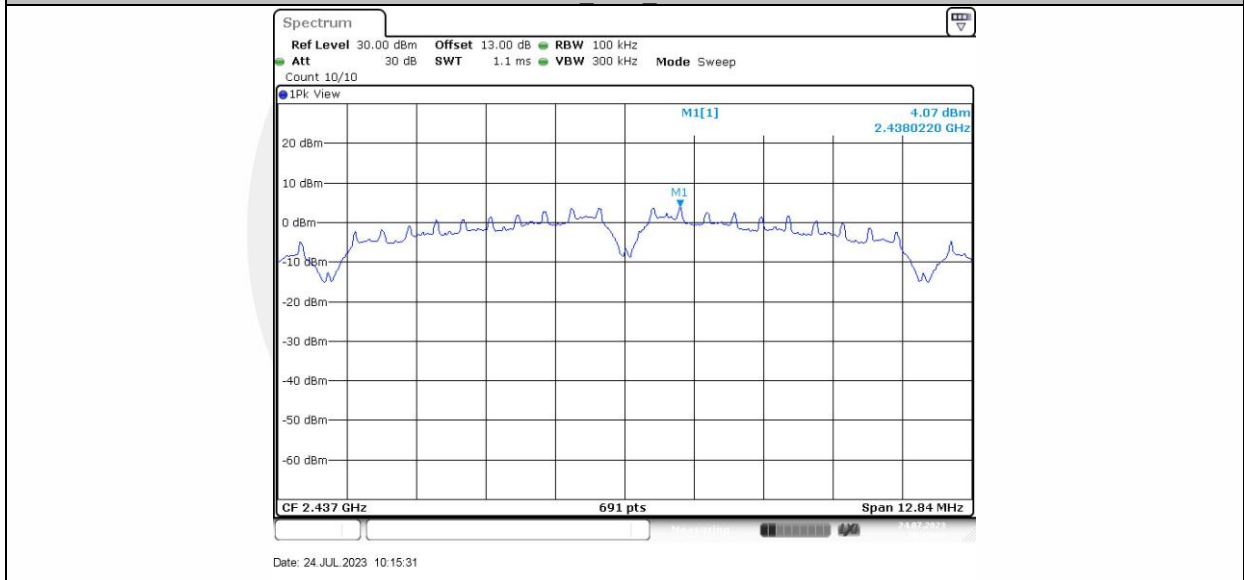

11B_Ant1_2437

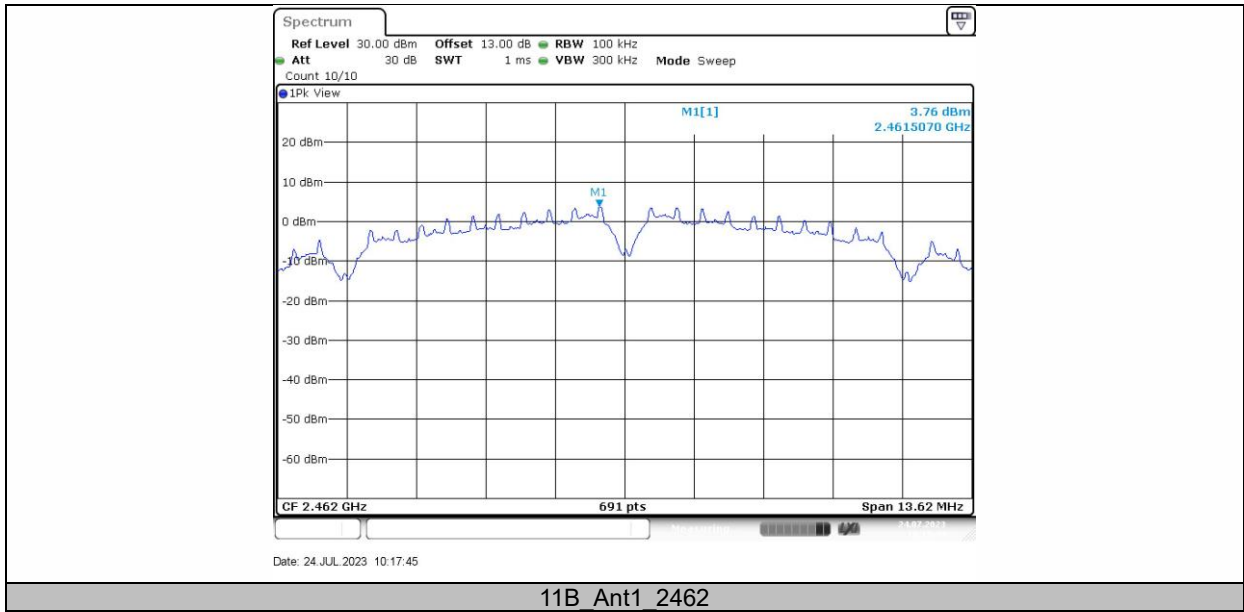

Band-edge measurement

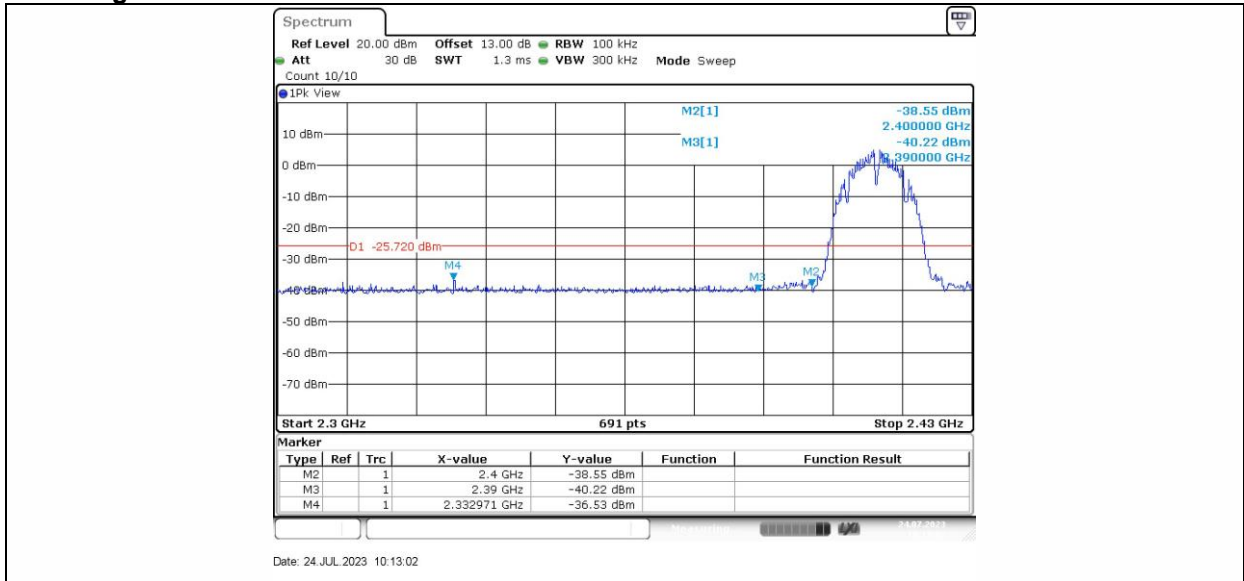

11B Ant1 Low 2412

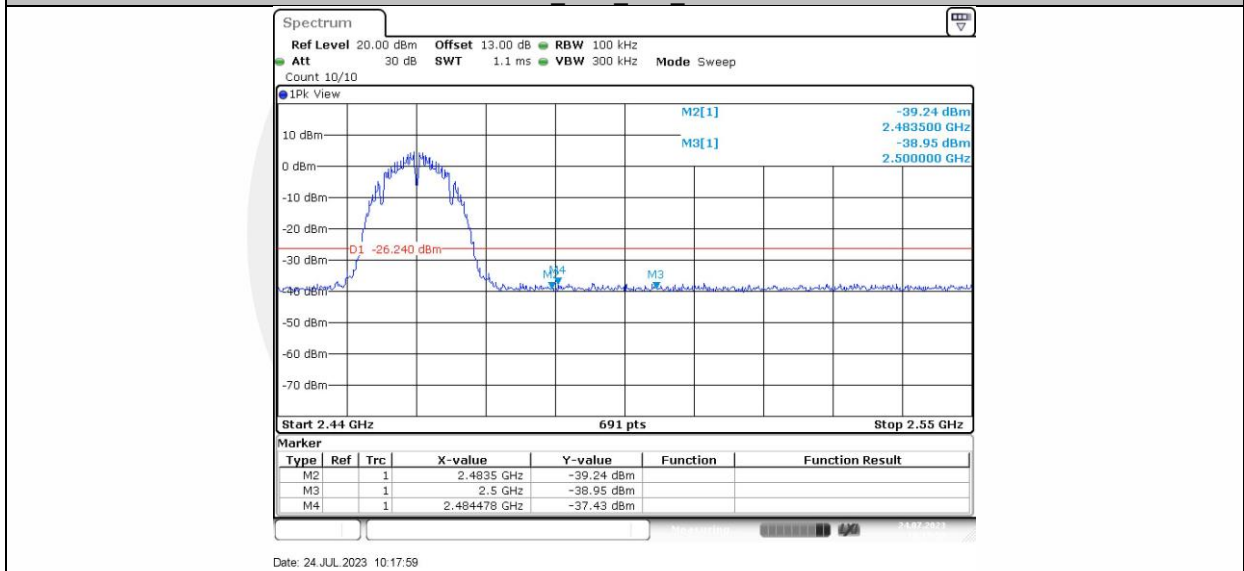

11B Ant1 High 2462

Emission level measurement

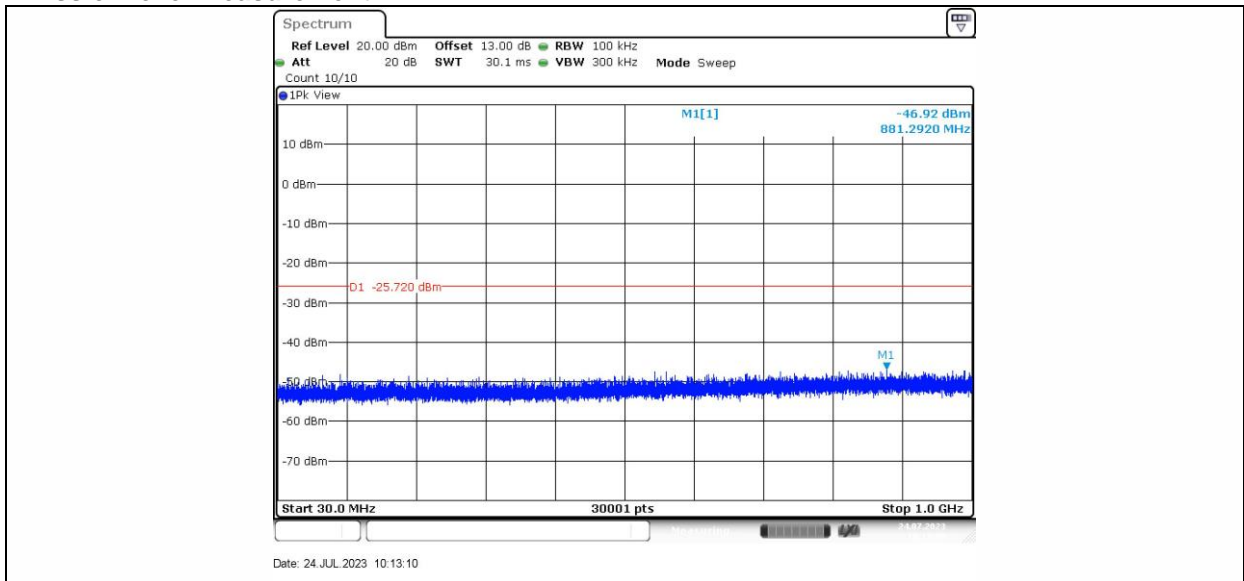

11B_Ant1_2412_30~1000

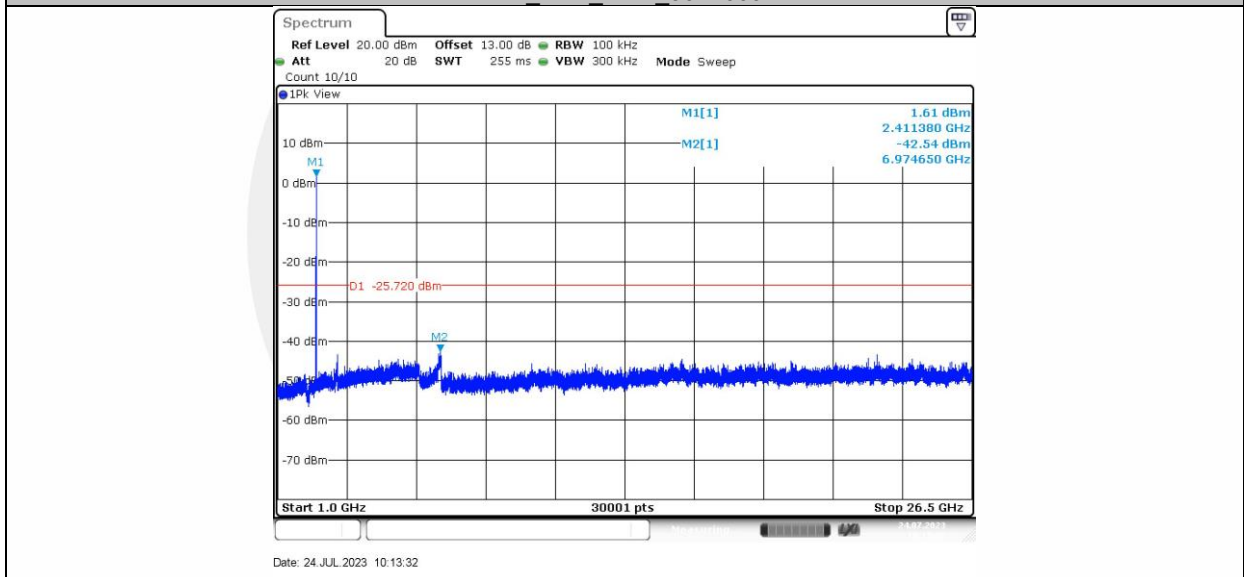

11B_Ant1_2412_1000~26500

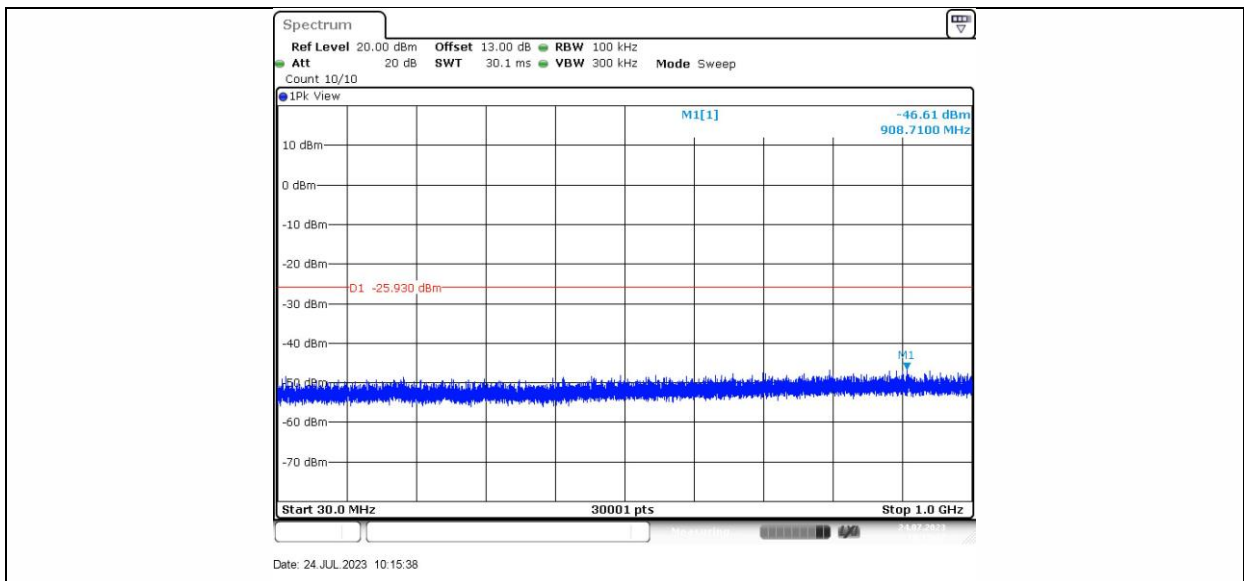

11B Ant1 2437 30~1000

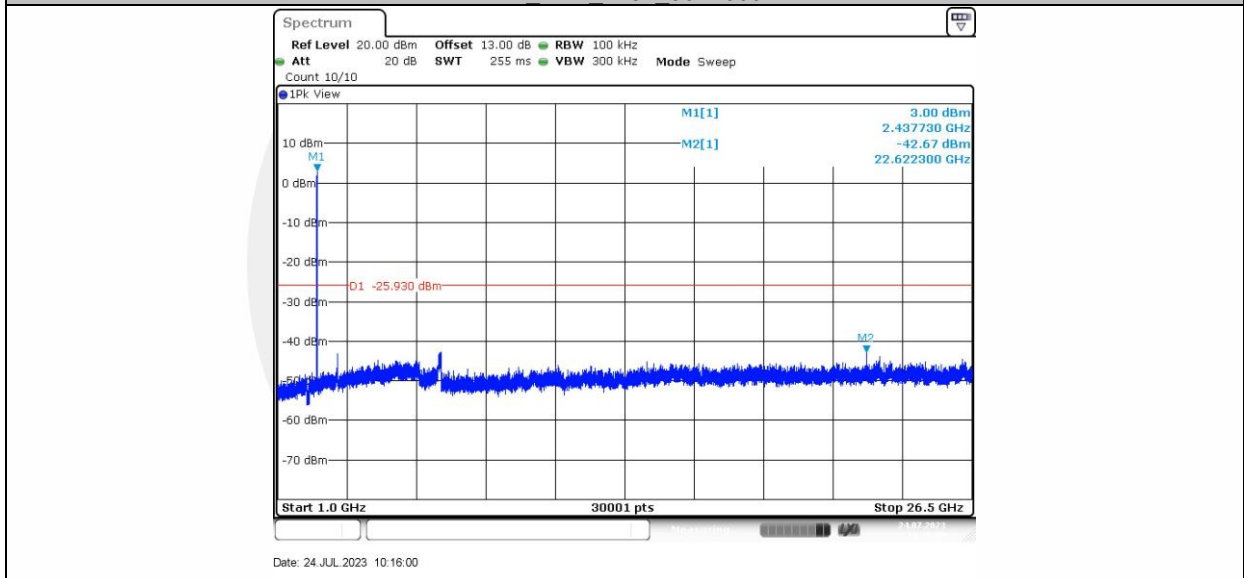

11B Ant1 2437 1000~26500

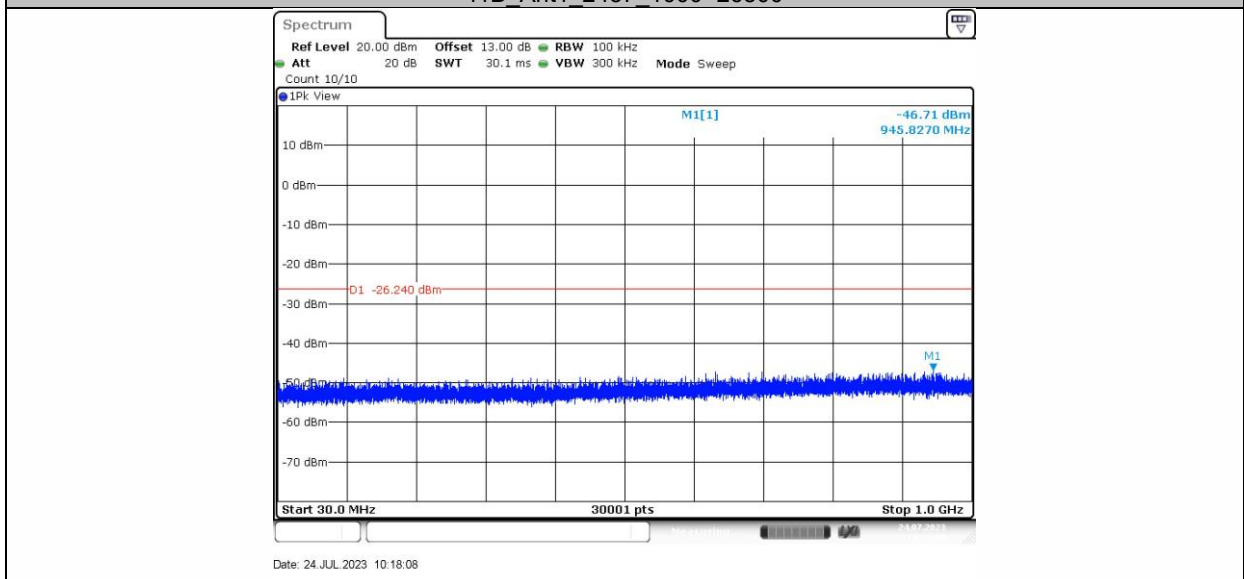

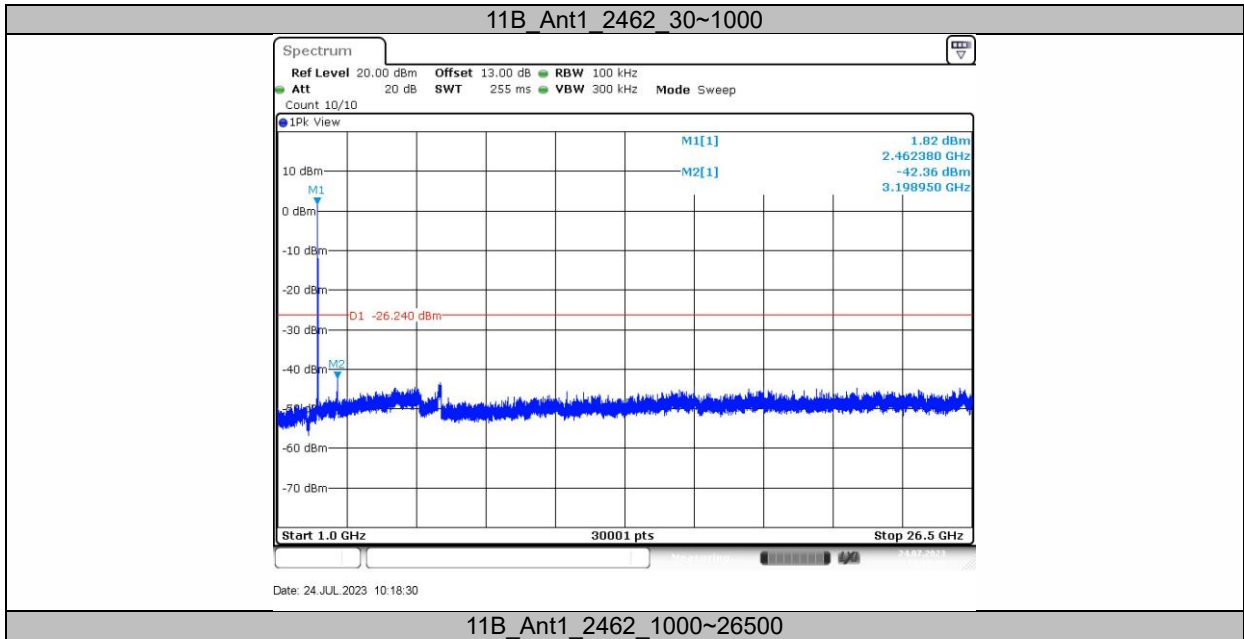

8.7 RADIATED SPURIOUS EMISSION

8.7.1 Applicable Standard

According to FCC Part 15.247(d), 15.205, 15.209
 According to RSS-Gen and RSS-247
 According to 558074 D01 15.247 Meas Guidance v05r02 Section 8.6
 According to ANSI C63.10 Section 11.12

8.7.2 Conformance Limit

According to FCC Part 15.247(d): radiated emissions which fall in the restricted bands, as defined in §15.205(a), must also comply with the radiated emission limits specified in §15.209(a) (see §15.205(c)).
 According to FCC Part 15.205, Restricted bands

MHz	MHz	MHz	GHz
0.090-0.110	16.42-16.423	399.9-410	4.5-5.15
0.495-0.505	16.69475-16.69525	608-614	5.35-5.46
2.1735-2.1905	16.80425-16.80475	960-1240	7.25-7.75
4.125-4.128	25.5-25.67	1300-1427	8.025-8.5
4.17725-4.17775	37.5-38.25	1435-1626.5	9.0-9.2
4.20725-4.20775	73-74.6	1645.5-1646.5	9.3-9.5
6.215-6.218	74.8-75.2	1660-1710	10.6-12.7
6.26775-6.26825	123-138	2200-2300	14.47-14.5
8.291-8.294	149.9-150.05	2310-2390	15.35-16.2
8.362-8.366	156.52475-156.52525	2483.5-2500	17.7-21.4
8.37625-8.38675	156.7-156.9	2690-2900	22.01-23.12
8.41425-8.41475	162.0125-167.17	3260-3267	23.6-24.0
12.29-12.293	167.72-173.2	3332-3339	31.2-31.8
12.51975-12.52025	240-285	3345.8-3358	36.43-36.5
12.57675-12.57725	322-335.4	3600-4400	Above 38.6
13.36-13.41			

According to FCC Part 15.205 the level of any transmitter spurious emission in Restricted bands shall not exceed the level of the emission specified in the following table

Restricted Frequency(MHz)	Field Strength (µV/m)	Field Strength (dBµV/m)	Measurement Distance
0.009-0.490	2400/F(KHz)	20 log (uV/m)	300
0.490-1.705	24000/F(KHz)	20 log (uV/m)	30
1.705-30	30	29.5	30
30-88	100	40	3
88-216	150	43.5	3
216-960	200	46	3
Above 960	500	54	3

8.7.3 Test Configuration

Test according to clause 7.2 radio frequency test setup

8.7.4 Test Procedure

This test is required for any spurious emission that falls in a Restricted Band, as defined in Section 15.205. It must be performed with the highest gain of each type of antenna proposed for use with the EUT. Use the following spectrum analyzer settings:

For Above 1GHz:

The EUT was placed on a turn table which is 1.5m above ground plane.

Maximum procedure was performed on the highest emissions to ensure EUT compliance.

Span = wide enough to fully capture the emission being measured

RBW = 1 MHz

VBW ≥ RBW

Sweep = auto

Detector function = peak

Trace = max hold

For average measurements the resolution bandwidth of spectrum analyzer is 1 MHz with the video bandwidth is $\geq 1/T$ with peak detector.

For Below 1GHz:

The EUT was placed on a turn table which is 0.8m above ground plane.

Maximum procedure was performed on the highest emissions to ensure EUT compliance.

Span = wide enough to fully capture the emission being measured

RBW = 100 kHz for

VBW \geq RBW

Sweep = auto

Detector function = peak

Trace = max hold

For Below 30MHz:

The EUT was placed on a turn table which is 0.8m above ground plane.

Maximum procedure was performed on the highest emissions to ensure EUT compliance.

Span = wide enough to fully capture the emission being measured

RBW = 9kHz

VBW \geq RBW

Sweep = auto

Detector function = peak

Trace = max hold

For Below 150KHz:

The EUT was placed on a turn table which is 0.8m above ground plane.

Maximum procedure was performed on the highest emissions to ensure EUT compliance.

Span = wide enough to fully capture the emission being measured

RBW = 200Hz

VBW \geq RBW

Sweep = auto

Detector function = peak

Trace = max hold

Follow the guidelines in ANSI C63.10 with respect to maximizing the emission by rotating the EUT, measuring the emission while the EUT is situated in three orthogonal planes (if appropriate), adjusting the measurement antenna height and polarization, etc. A pre-amp and a high pass filter are required for this test, in order to provide the measuring system with sufficient sensitivity. Allow the trace to stabilize. The peak reading of the emission, after being corrected by the antenna factor, cable loss, pre-amp gain, etc., is the peak field strength, which must comply with the limit. Submit this data.

8.7.5 Test Results

Temperature:	26° C
Relative Humidity:	54%
ATM Pressure:	1011 mbar
Test Engineer:	XXH

■ Spurious Emission below 30MHz(9KHz to 30MHz)

For Spurious Emission below 30MHz (9KHz to 30MHz), was pre-scanned and the result which was 20dB lower than the limit line per 15.31(o) was not reported.

■ Spurious Emission Above 1GHz(1GHz to 25GHz)

All the antenna(Antenna 1) and modes(802.11b/g/n) have been tested and the worst(Antenna 1, 802.11b) result recorded was report as below:

Test mode: 802.11b Frequency: Channel 1: 2412MHz

Freq. (MHz)	Ant.Pol.	Reading Level (dBuV/m)	Correct Factor (dB/m)	Corrected Reading (dBuV/m)	Limit 3m (dBuV/m)	Margin (dB)	Remark
11375.6	V	57.11	3.47	60.58	74.00	13.42	Peak
14643.7	V	53.46	10.28	63.74	74.00	10.26	Peak
17638.1	V	56.16	14.91	71.07	74.00	2.93	Peak
11375.62	V	43.11	3.47	46.58	54.00	7.42	Avg
14643.75	V	37.56	10.28	47.84	54.00	6.16	Avg
17638.12	V	34.21	14.91	49.12	54.00	4.88	Avg
11505	H	55.79	4.57	60.36	74.00	13.64	Peak
14565	H	54.25	10.15	64.40	74.00	9.60	Peak
17610	H	53.99	15.81	69.80	74.00	4.20	Peak
11505	H	43.55	4.57	48.12	54.00	5.88	Avg
14565	H	37.21	10.15	47.36	54.00	6.64	Avg
17610	H	34.11	15.81	49.92	54.00	4.08	Avg

Note: (1) PeaK RBW = 1 MHz, VBW ≥ 3 × RBW, Detector = Peak;
 (2) Avg RBW = 1 MHz, VBW = 1/T_{on}, Detector = Peak, where: T_{on} is transmit duration;
 (3) Corrected Reading = Reading Level + Correct Factor;
 (4) Correct Factor = Ant_F + Cab_L - Preamp;
 (5) Margin = Limit - Corrected Reading;

Test mode: 802.11b Frequency: Channel 6: 2437MHz

Freq. (MHz)	Ant.Pol.	Reading Level (dBuV/m)	Correct Factor (dB/m)	Corrected Reading (dBuV/m)	Limit 3m (dBuV/m)	Margin (dB)	Remark
11371.875	V	56.96	3.50	60.46	74.00	13.54	Peak
14670	V	54.36	9.70	64.06	74.00	9.94	Peak
17630.625	V	55.8	15.15	70.95	74.00	3.05	Peak
11371.875	V	43.54	3.50	47.04	54.00	6.96	Avg
14670	V	37.11	9.70	46.81	54.00	7.19	Avg
17630.625	V	34.55	15.15	49.70	54.00	4.30	Avg
11521.875	H	56.66	4.21	60.87	74.00	13.13	Peak
14557.5	H	54.39	9.91	64.30	74.00	9.70	Peak
17613.75	H	54.08	15.69	69.77	74.00	4.23	Peak
11521.875	H	43.52	4.21	47.73	54.00	6.27	Avg
14557.5	H	37.58	9.91	47.49	54.00	6.51	Avg
17613.75	H	34.77	15.69	50.46	54.00	3.54	Avg

Note: (1) Peak RBW = 1 MHz, VBW $\geq 3 \times$ RBW, Detector = Peak;
 (2) Avg RBW = 1 MHz, VBW = $1/T_{on}$, Detector = Peak, where: T_{on} is transmit duration;
 (3) Corrected Reading = Reading Level + Correct Factor;
 (4) Correct Factor = Ant_F + Cab_L - Preamp;
 (5) Margin = Limit - Corrected Reading;

Test mode: 802.11b Frequency: Channel 11: 2462MHz

Freq. (MHz)	Ant.Pol.	Reading Level (dBuV/m)	Correct Factor (dB/m)	Corrected Reading (dBuV/m)	Limit 3m (dBuV/m)	Margin (dB)	Remark
11518.125	V	56.04	4.30	60.34	74.00	13.66	Peak
14641.875	V	53.63	10.32	63.95	74.00	10.05	Peak
17608.125	V	54.22	15.87	70.09	74.00	3.91	Peak
11518.125	V	43.66	4.30	47.96	54.00	6.04	Avg
14641.875	V	37.51	10.32	47.83	54.00	6.17	Avg
17608.125	V	34.25	15.87	50.12	54.00	3.88	Avg
11497.5	H	55.4	4.63	60.03	74.00	13.97	Peak
14658.75	H	54.31	9.95	64.26	74.00	9.74	Peak
17613.75	H	53.7	15.69	69.39	74.00	4.61	Peak
11497.5	H	43.11	4.63	47.74	54.00	6.26	Avg
14658.75	H	37.56	9.95	47.51	54.00	6.49	Avg
17613.75	H	34.65	15.69	50.34	54.00	3.66	Avg
Note: (1) Peak RBW = 1 MHz, VBW $\geq 3 \times$ RBW, Detector = Peak; (2) Avg RBW = 1 MHz, VBW = $1/T_{on}$, Detector = Peak, where: T_{on} is transmit duration; (3) Corrected Reading = Reading Level + Correct Factor; (4) Correct Factor = Ant_F + Cab_L - Preamp; (5) Margin = Limit - Corrected Reading;							

■ Spurious Emission in Restricted Band 2310-2390MHz and 2483.5-2500MHz

All the antenna(Antenna 1) and modes(802.11b/g/n) have been tested and the worst(Antenna 1, 802.11b) result recorded was report as below:

Test mode: 802.11b Frequency: Channel 1: 2412MHz

Freq. (MHz)	Ant.Pol.	Reading Level (dBuV/m)	Correct Factor (dB/m)	Corrected Reading (dBuV/m)	Limit 3m (dBuV/m)	Margin (dB)	Remark
2344.02	V	14.13	30.99	45.12	74.00	28.88	peak
2344.02	V	11.55	30.99	42.54	54.00	11.46	AVG
2349.77	H	14.53	30.99	45.52	74.00	28.48	peak
2349.77	H	11.74	30.99	42.73	54.00	11.27	AVG
Note: (1) Peak RBW = 1 MHz, VBW $\geq 3 \times$ RBW, Detector = Peak; (2) Avg RBW = 1 MHz, VBW $\geq 3 \times$ RBW, Detector = RMS; (3) Corrected Reading = Reading Level + Correct Factor; (4) Correct Factor = Ant_F + Cab_L - Preamp; (5) Margin = Limit - Corrected Reading;							

Test mode: 802.11b Frequency: Channel 11: 2462MHz

Freq. (MHz)	Ant.Pol.	Reading Level (dBuV/m)	Correct Factor (dB/m)	Corrected Reading (dBuV/m)	Limit 3m (dBuV/m)	Margin (dB)	Remark
2490.71	V	15.35	30.98	46.33	74.00	27.67	peak
2490.71	V	12.01	30.98	42.99	54.00	11.01	AVG
2487.67	H	16.4	30.98	47.38	74.00	26.62	peak
2487.67	H	11.44	30.98	42.42	54.00	11.58	AVG
Note: (1) Peak RBW = 1 MHz, VBW $\geq 3 \times$ RBW, Detector = Peak; (2) Avg RBW = 1 MHz, VBW = $1/T_{on}$, Detector = Peak, where: T_{on} is transmit duration; (3) Corrected Reading = Reading Level + Correct Factor; (4) Correct Factor = Ant_F + Cab_L - Preamp; (5) Margin = Limit - Corrected Reading;							

Test Model **Spurious Emission in Restricted Band 2310-2390MHz**
802.11b **Channel 1: 2412MHz** **Polarity: H**

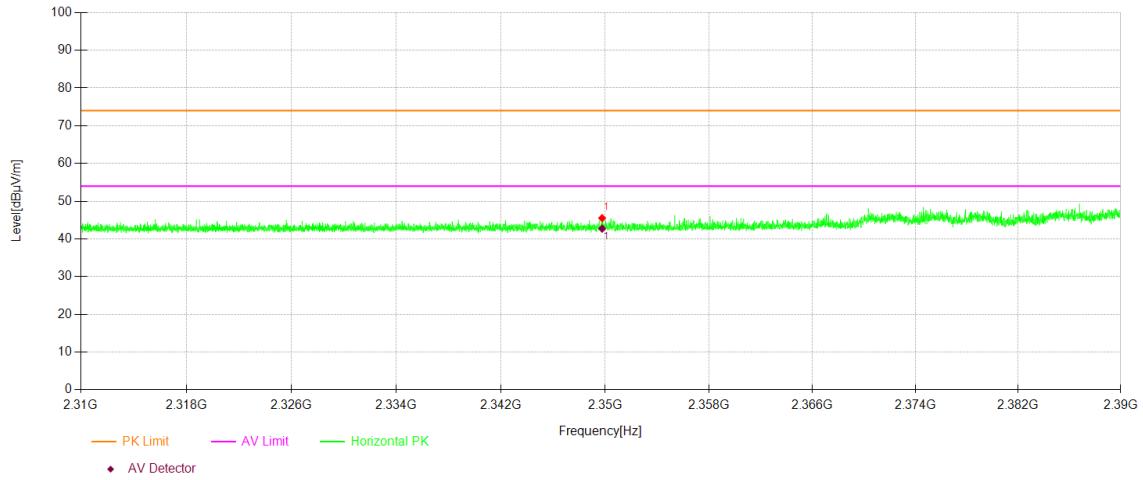

Test Model **Spurious Emission in Restricted Band 2310-2390MHz**
802.11b **Channel 1: 2412MHz** **Polarity: V**

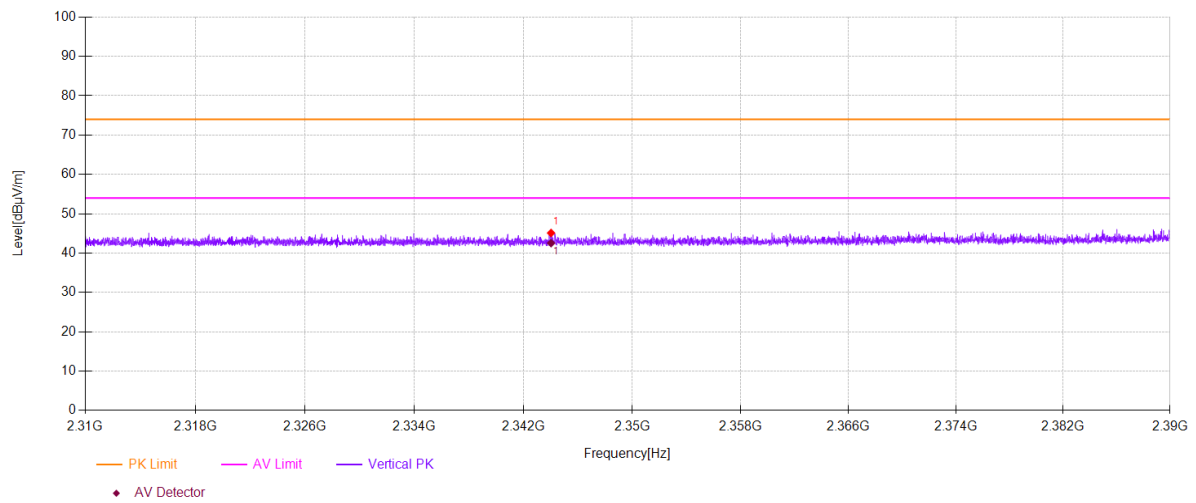

Test Model **Spurious Emission in Restricted Band 2483.5-2500MHz**
802.11b **Channel 11: 2462MHz** **Polarity: H**

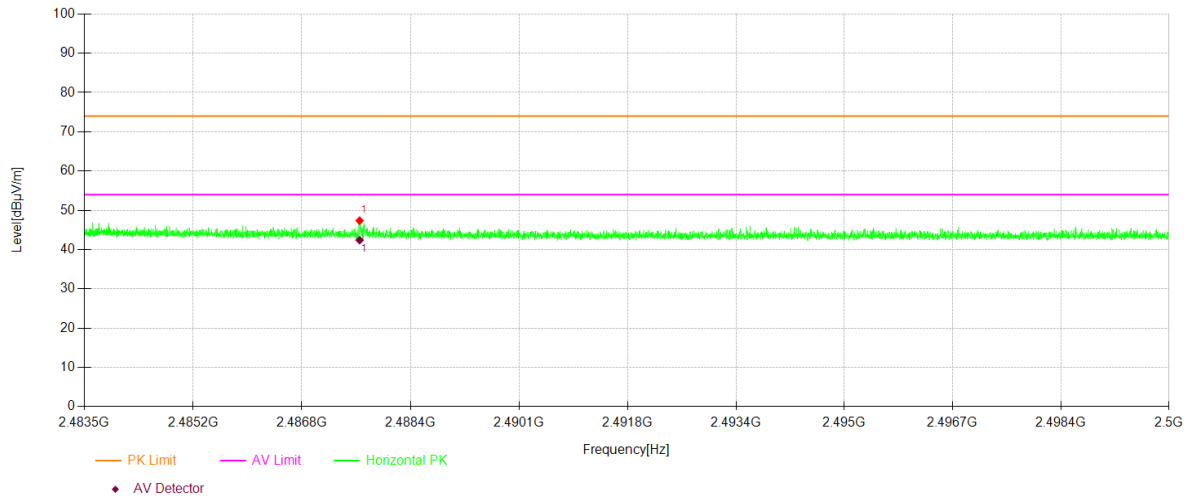

Test Model **Spurious Emission in Restricted Band 2483.5-2500MHz**
802.11b **Channel 11: 2462MHz** **Polarity: V**

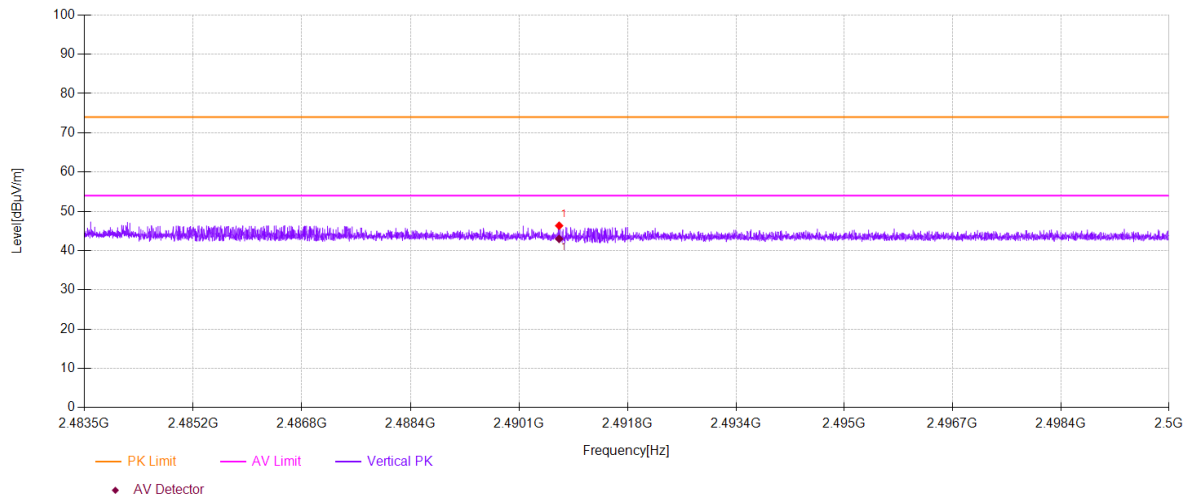

■ Spurious Emission below 1GHz (30MHz to 1GHz)

All the antenna(Antenna 1) and modes(802.11b/g/n) have been tested and the worst(Antenna 1, 802.11b) result recorded was report as below:

2412

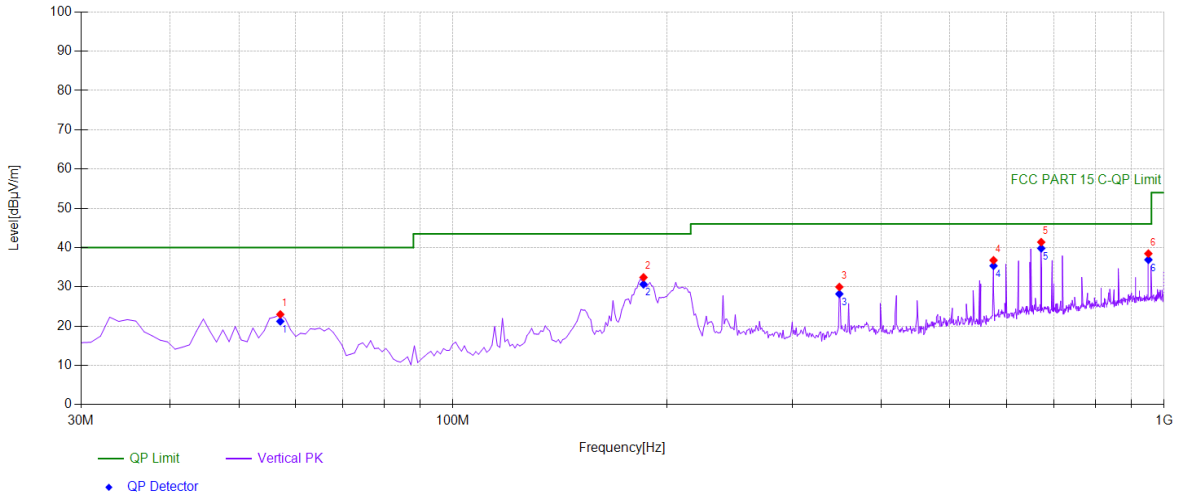

Suspected Data List								
NO.	Freq. [MHz]	Reading [dBµV]	Factor [dB/m]	Level [dBµV/m]	Detector	Limit [dBµV/m]	Margin [dB]	Polarity
1	57.1872	41.15	-18.16	22.99	PK	40.00	17.01	Vertical
2	185.355	50.47	-18.05	32.42	PK	43.50	11.08	Vertical
3	349.449	43.44	-13.47	29.97	PK	46.00	16.03	Vertical
4	575.685	44.30	-7.53	36.77	PK	46.00	9.23	Vertical
5	671.811	47.53	-6.14	41.39	PK	46.00	4.61	Vertical
6	950.480	40.80	-2.33	38.47	PK	46.00	7.53	Vertical

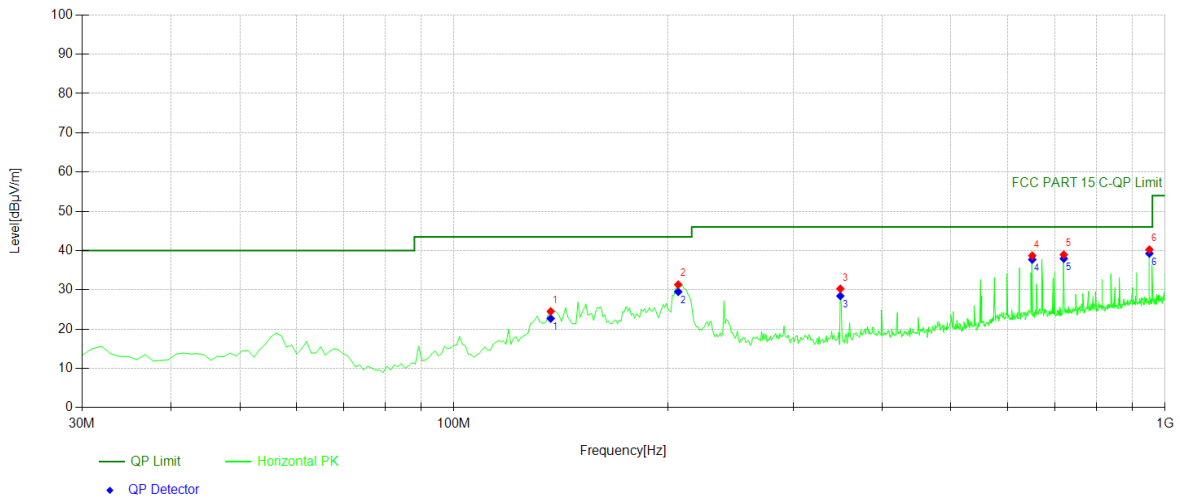

Suspected Data List								
NO.	Freq. [MHz]	Reading [dBµV]	Factor [dB/m]	Level [dBµV/m]	Detector	Limit [dBµV/m]	Margin [dB]	Polarity
1	136.806	44.21	-19.68	24.53	PK	43.50	18.97	Horizontal
2	206.716	48.47	-17.13	31.34	PK	43.50	12.16	Horizontal
3	349.449	43.74	-13.47	30.27	PK	46.00	15.73	Horizontal
4	650.450	44.93	-6.22	38.71	PK	46.00	7.29	Horizontal
5	720.360	44.77	-5.81	38.96	PK	46.00	7.04	Horizontal
6	950.480	42.59	-2.33	40.26	PK	46.00	5.74	Horizontal

2437

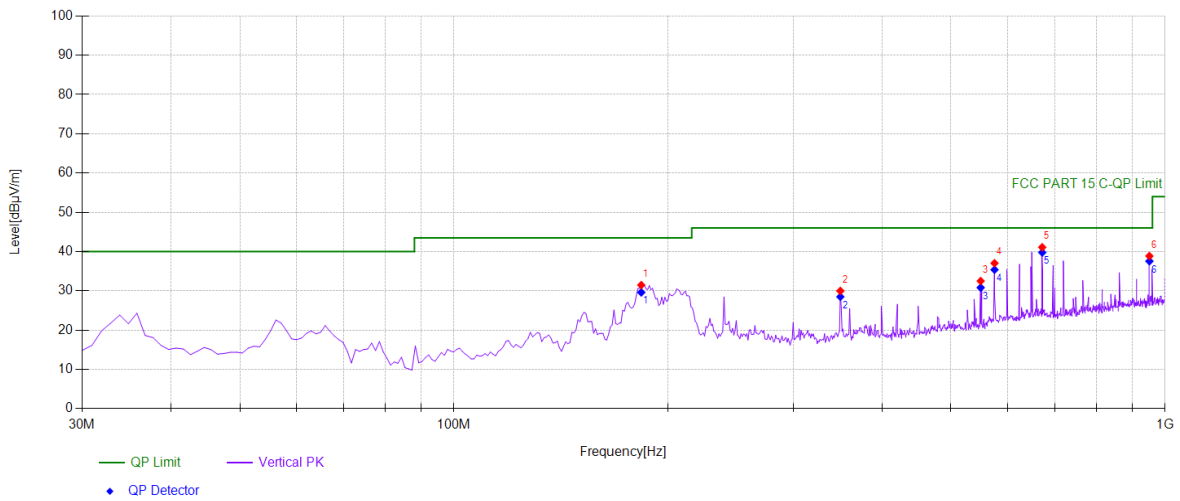

Suspected Data List								
NO.	Freq. [MHz]	Reading [dBµV]	Factor [dB/m]	Level [dBµV/m]	Detector	Limit [dBµV/m]	Margin [dB]	Polarity
1	183.413	49.64	-18.17	31.47	PK	43.50	12.03	Vertical
2	349.449	43.46	-13.47	29.99	PK	46.00	16.01	Vertical
3	550.440	41.70	-9.20	32.50	PK	46.00	13.50	Vertical
4	575.685	44.58	-7.53	37.05	PK	46.00	8.95	Vertical
5	671.811	47.24	-6.14	41.10	PK	46.00	4.90	Vertical
6	950.480	41.20	-2.33	38.87	PK	46.00	7.13	Vertical

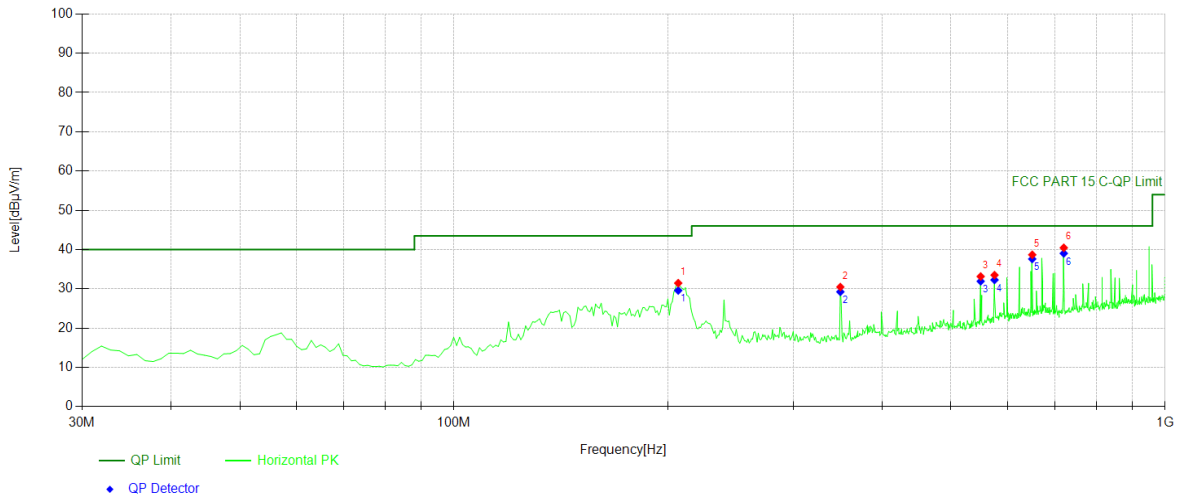

Suspected Data List								
NO.	Freq. [MHz]	Reading [dBµV]	Factor [dB/m]	Level [dBµV/m]	Detector	Limit [dBµV/m]	Margin [dB]	Polarity
1	206.716	48.59	-17.13	31.46	PK	43.50	12.04	Horizontal
2	349.449	43.95	-13.47	30.48	PK	46.00	15.52	Horizontal
3	550.440	42.35	-9.20	33.15	PK	46.00	12.85	Horizontal
4	575.685	41.04	-7.53	33.51	PK	46.00	12.49	Horizontal
5	650.450	44.90	-6.22	38.68	PK	46.00	7.32	Horizontal
6	720.360	46.28	-5.81	40.47	PK	46.00	5.53	Horizontal

2480

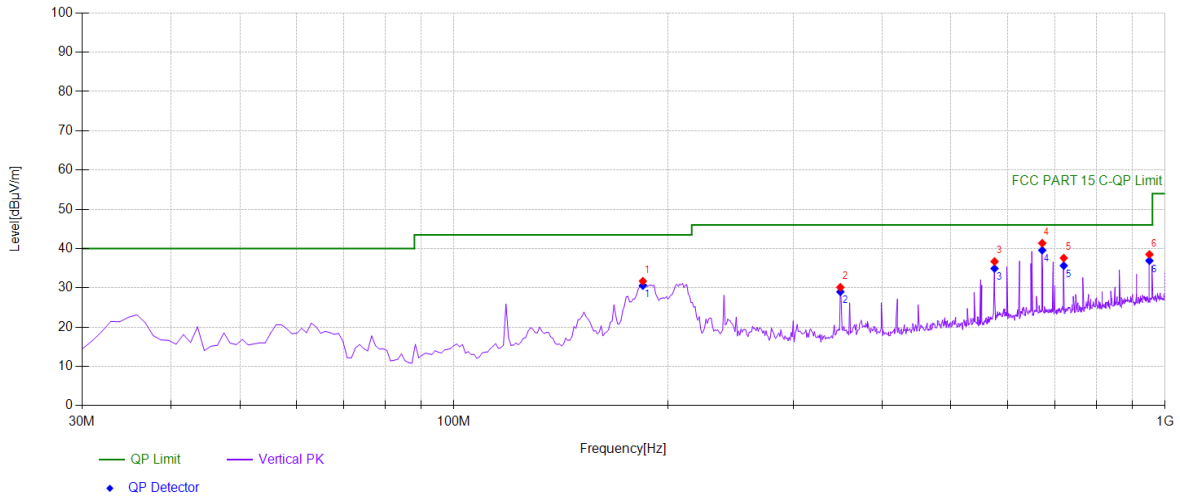

Suspected Data List								
NO.	Freq. [MHz]	Reading [dBµV]	Factor [dB/m]	Level [dBµV/m]	Detector	Limit [dBµV/m]	Margin [dB]	Polarity
1	184.384	49.83	-18.11	31.72	PK	43.50	11.78	Vertical
2	349.449	43.61	-13.47	30.14	PK	46.00	15.86	Vertical
3	575.685	44.25	-7.53	36.72	PK	46.00	9.28	Vertical
4	671.811	47.52	-6.14	41.38	PK	46.00	4.62	Vertical
5	720.360	43.41	-5.81	37.60	PK	46.00	8.40	Vertical
6	950.480	40.84	-2.33	38.51	PK	46.00	7.49	Vertical

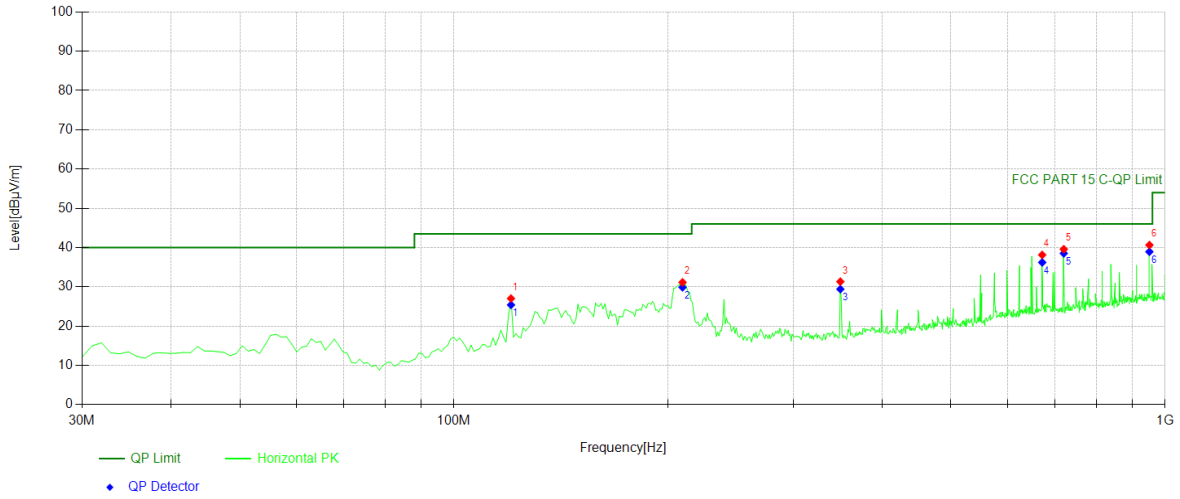

Suspected Data List

NO.	Freq. [MHz]	Reading [dBµV]	Factor [dB/m]	Level [dBµV/m]	Detector	Limit [dBµV/m]	Margin [dB]	Polarity
1	120.300	44.99	-17.95	27.04	PK	43.50	16.46	Horizontal
2	209.629	48.29	-17.13	31.16	PK	43.50	12.34	Horizontal
3	349.449	44.80	-13.47	31.33	PK	46.00	14.67	Horizontal
4	671.811	44.28	-6.14	38.14	PK	46.00	7.86	Horizontal
5	720.360	45.40	-5.81	39.59	PK	46.00	6.41	Horizontal
6	950.480	42.98	-2.33	40.65	PK	46.00	5.35	Horizontal

8.8 CONDUCTED EMISSION TEST

8.8.1 Applicable Standard

According to FCC Part 15.207(a)

According to RSS-Gen 8.8

8.8.2 Conformance Limit

Frequency(MHz)	Conducted Emission Limit	
	Quasi-peak	Average
0.15-0.5	66-56	56-46
0.5-5.0	56	46
5.0-30.0	60	50

Note: 1. The lower limit shall apply at the transition frequencies
 2. The limit decreases in line with the logarithm of the frequency in the range of 0.15 to 0.50MHz.

8.8.3 Test Configuration

Test according to clause 7.3 conducted emission test setup

8.8.4 Test Procedure

The EUT was placed on a table which is 0.8m above ground plane.
 Maximum procedure was performed on the highest emissions to ensure EUT compliance.
 Repeat above procedures until all frequency measured were complete.

8.8.5 Test Results

Pass

The AC120V &240V voltage have been tested, and the worst result recorded was report as below:

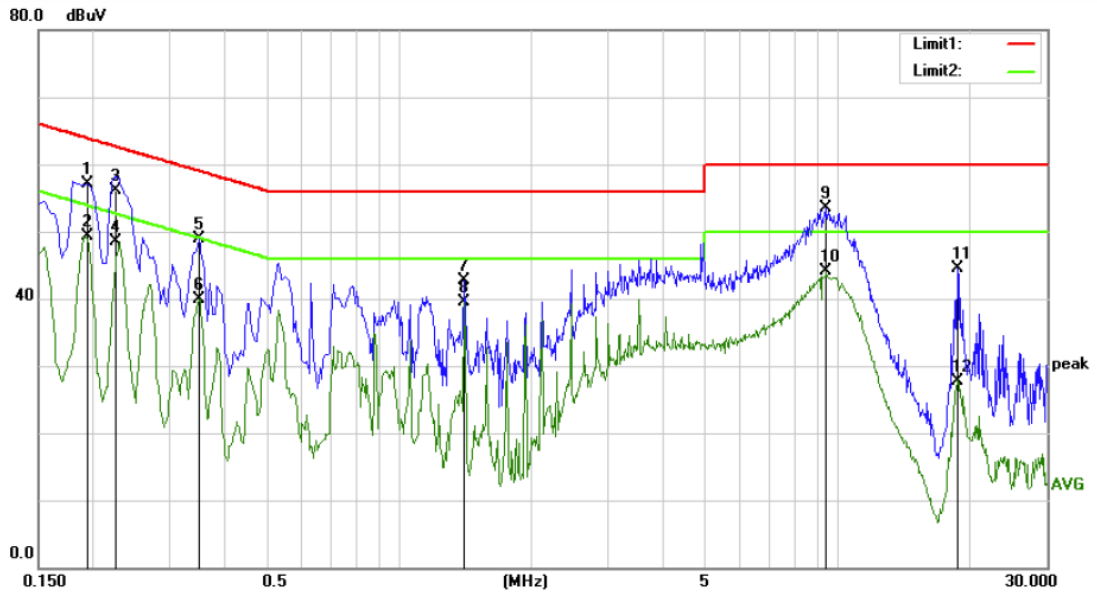

Site Conduction #1 Phase: **N** Temperature: 21.9
 Limit: (CE)FCC PART 15 class B_QP Power: AC 120V/60Hz Humidity: 58 %
 Mode: WIFI
 Note:

No.	Mk.	Freq.	Reading Level	Correct Factor	Measurement	Limit	Over	Detector	Comment
		MHz	dBuV	dB	dBuV	dBuV	dB		
1		0.1950	47.01	10.04	57.05	63.82	-6.77	QP	
2		0.1950	39.23	10.04	49.27	53.82	-4.55	AVG	
3		0.2250	46.12	10.08	56.20	62.63	-6.43	QP	
4	*	0.2250	38.39	10.08	48.47	52.63	-4.16	AVG	
5		0.3500	38.96	9.93	48.89	58.96	-10.07	QP	
6		0.3500	30.03	9.93	39.96	48.96	-9.00	AVG	
7		1.4100	32.89	9.79	42.68	56.00	-13.32	QP	
8		1.4100	29.81	9.79	39.60	46.00	-6.40	AVG	
9		9.4050	43.41	10.03	53.44	60.00	-6.56	QP	
10		9.4050	33.98	10.03	44.01	50.00	-5.99	AVG	
11		18.7300	34.31	10.25	44.56	60.00	-15.44	QP	
12		18.7300	17.55	10.25	27.80	50.00	-22.20	AVG	

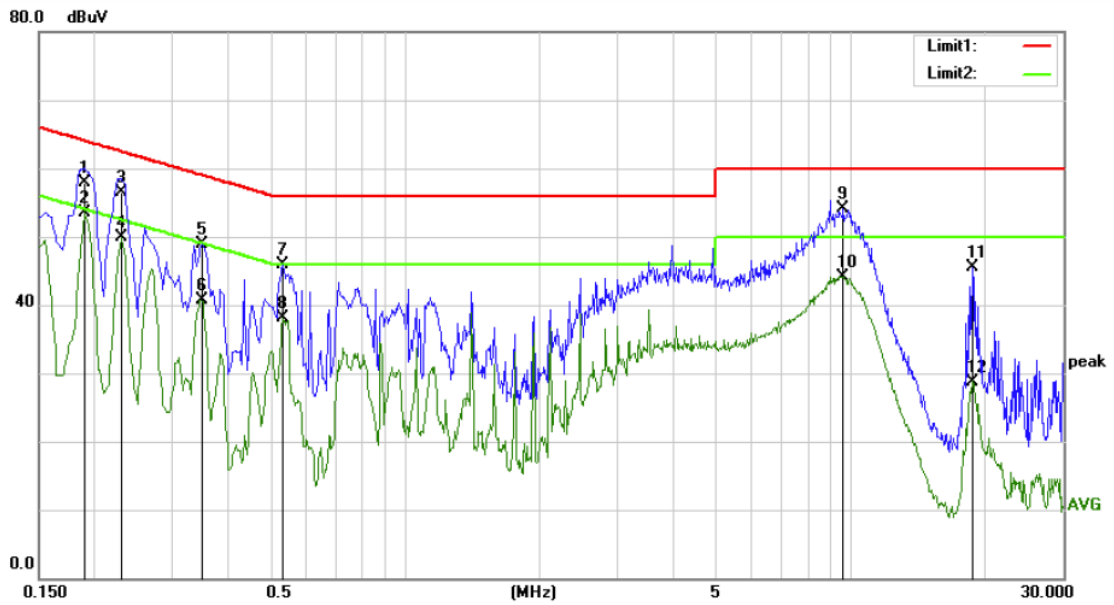

Site Conduction #1 Phase: **L1** Temperature: 21.9
 Limit: (CE)FCC PART 15 class B_QP Power: AC 120V/60Hz Humidity: 58 %
 Mode: WIFI
 Note:

No.	Mk.	Freq. MHz	Reading Level dBuV	Correct Factor dB	Measure- ment dBuV	Limit		Detector	Comment
						dBuV	dB		
1		0.1900	48.02	9.98	58.00	64.04	-6.04	QP	
2	*	0.1900	43.43	9.98	53.41	54.04	-0.63	AVG	
3		0.2300	46.42	10.08	56.50	62.45	-5.95	QP	
4		0.2300	39.91	10.08	49.99	52.45	-2.46	AVG	
5		0.3500	38.90	9.93	48.83	58.96	-10.13	QP	
6		0.3500	30.82	9.93	40.75	48.96	-8.21	AVG	
7		0.5300	36.16	9.67	45.83	56.00	-10.17	QP	
8		0.5300	28.46	9.67	38.13	46.00	-7.87	AVG	
9		9.6050	44.08	10.03	54.11	60.00	-5.89	QP	
10		9.6050	34.16	10.03	44.19	50.00	-5.81	AVG	
11		18.7300	35.24	10.25	45.49	60.00	-14.51	QP	
12		18.7300	18.55	10.25	28.80	50.00	-21.20	AVG	

8.9 ANTENNA APPLICATION

8.9.1 Antenna Requirement

Standard	Requirement
FCC CRF Part 15.203	An intentional radiator shall be designed to ensure that no antenna other than that furnished by the responsible party shall be used with the device. The use of a permanently attached antenna or of an antenna that uses a unique coupling to the intentional radiator shall be considered sufficient to comply with the provisions of this section. The manufacturer may design the unit so that a broken antenna can be replaced by the user, but the use of a standard antenna jack or electrical connector is prohibited.
FCC 47 CFR Part 15.247 (b)	If transmitting antennas of directional gain greater than 6dBi are used, the power shall be reduced by the amount in dB that the directional gain of the antenna exceeds 6dBi.
RSS-Gen Section 6.8	The applicant for equipment certification shall provide a list of all antenna types that may be used with the transmitter, where applicable (i.e. for transmitters with detachable antenna), indicating the maximum permissible antenna gain (in dBi) and the required impedance for each antenna. The test report shall demonstrate the compliance of the transmitter with the limit for maximum equivalent isotropically radiated power (e.i.r.p.) specified in the applicable RSS, when the transmitter is equipped with any antenna type, selected from this list.
RSS-247 Section 5.4	If the transmitter employs an antenna system that emits multiple directional beams, but does not emit multiple directional beams simultaneously, the total output power conducted to the array or arrays that comprise the device (i.e. the sum of the power supplied to all antennas, antenna elements, staves, etc., and summed across all carriers or frequency channels) shall not exceed the applicable output power limit. However, the total conducted output power shall be reduced by 1 dB below the specified limits for each 3 dB that the directional gain of the antenna/antenna array exceeds 6 dBi. The directional antenna gain shall be computed as the sum of 10 log (number of array elements or staves) plus the directional gain of the element or stave having the highest gain.

8.9.2 Result

PASS.

- Note:
- Antenna use a permanently attached antenna which is not replaceable.
 - Not using a standard antenna jack or electrical connector for antenna replacement
 - The antenna has to be professionally installed (please provide method of installation)

Please refer to the attached document Internal Photos to show the antenna connector.

----- END OF REPORT -----