

Shenzhen silver dragon Tengfei Electronics Co., LTD
深圳市银龙腾飞电子有限公司

客户/Client 高易电子

料号/NO

产品型号 Model NO 丝包 线圈 Silk covered coil 43.5*5.3*1.0H-6.3UH

客户料号 Silk covered coil

工程编号 Project number

日期/Date 2023-12--6

本公司工程部/Engineering Department of our compan	
修改内容/Modify content	认可日期/date

编制/Prepared

审核/Checked

认可/Approved

客户认可回签 The customer accepts the countersign		
工程/ENGINEERING	认可/QC	认可日期/date

一、 线圈工艺/ Coil technology

NO	绕组 winding	线规 Wire gauge	匝数 Number of turns	绕线方向 Winding direction	备注 remark
1	N1	2UEW-B-0.08*105P	10TS	CCW	
2					

二. 电气性能/FEATURES:

1.测试条件 (Test conditions) : 25°C,65%RH@1KHz/0.25V

1.1 电感量 (Inductance)

1.11 Individual coil
 L0A (单独线圈) =5.0uH ± 10%

1.12 Coil + diskette
 L0A(线圈+磁片)=6.3uH ± 10%

1.2 Q value
 Q 值=70MIN

1.3 直流电阻 (DCR) : 55mΩ MAX

1.4 工作温度(Operating Temperature): -25°C ~85°C

2.测试仪器(Test instrument) : L:创达 1068+1310;DCR:502BC;SIZE:Callipers

3.材料清单/Bill of materials

NO	项目/item	材料/Materials
1	WIRE	φ 0.08*105p 2UEW-1.1mm
2	FERRITE	43.5*5.3*1.0H Single hole double slot ferrite hard magnetic
3	GLUE	白胶 White glue
4	SOLDER	XCD-907B
5	Adhesive	普通背胶 Common adhesive
6	High temperature adhesive	
7		
8		

三. 电路图/CIRCUIT DIAGRAM



单位unit : MM

四. 外形图/OUTSIDE DIAGRA

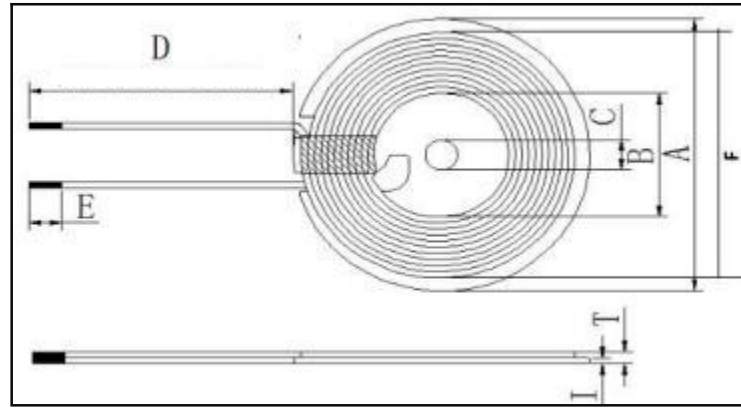

标准	A	B	C	D	E	F	I	T
STD	43.5	20.5±0.5	5.30±0.2	25±2	2.5±1	42.±0.5	1.0±0.2	2.6Max

单位unit: MM

五. 包装/PACKAGE

5.1 包装图片 Packing pictures:

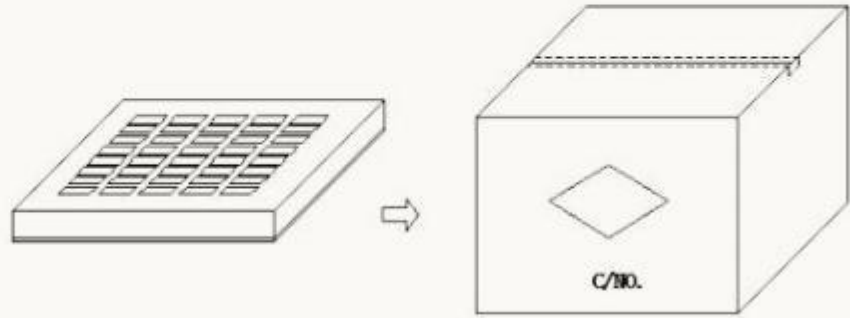

5.2 包装数量及规格 Packing Quantity:

项目 Item	数量 Quantity	材料规格 Material
盒 Box	350 Pcs	345*330*50 mm
箱 Big Carton	1440 Pcs	360*340*280 mm

六、贮存和使用条件 Storage and Use condition

6.1 贮存条件 Storage condition

6.1.1 建议贮存条件：温度 $-25^{\circ}\text{C} \sim 85^{\circ}\text{C}$ ，湿度 70% (Max.)

Recommended keeping conditions: $-25^{\circ}\text{C} \sim 85^{\circ}\text{C}$, 70%RH (Max.)

6.1.2 贮存期限：自生产之日起六个月内

Storage life : Within the limits of six months from being produced.

6.2 使用条件 Use condition

使用条件限制：温度 $-25^{\circ}\text{C} \sim 85^{\circ}\text{C}$ ，湿度 $\leq 90\%$

Use condition limit: $T=-25^{\circ}\text{C} \sim 85^{\circ}\text{C}$, $\text{RH} \leq 90\%$.