

1、Dimensions(unit:mm)

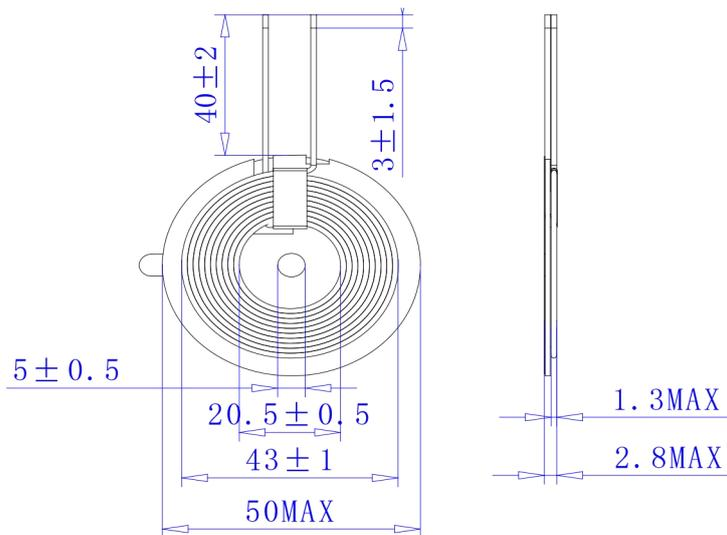

2、Electrical performance

Project	Standard	Test condition	Test instrument	remarks
inductance	$3.6 \pm 10\%$	100KHZ,1V	TH2817B+	Coil type
Inductance 1	$6.3 \pm 10\%$	100KHZ,1V	TH2817B+	Measuring type with magnetic sheet
Resistance(DCR)	45mΩMAX	@25°C	AT516	
Q value	70MIN	100KHZ,1V	TH2817B+	

Appearance requirements:

- 1) The shape and size of products shall be strictly controlled
- 2) The product surface is free of oil, impurities, burrs, etc
- 3) Materials cannot be changed without customer's confirmation
- 4) The product must meet Rosh requirements