

C20Pro

Watch client download

Scan the QR code below to download and install the watch client.

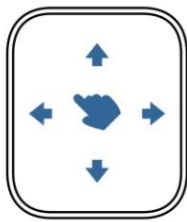

Sliding horizontal line menu style Jiu Gongge menu style Honeycomb menu style

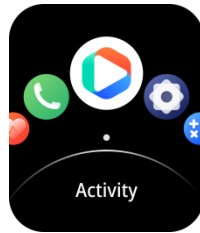

Flat Menu Style Rudder Menu Style Full Moon Menu Style New Moon Menu Style

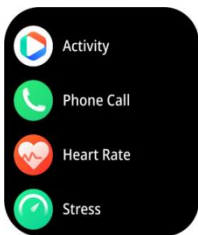

List menu style

Full touch

Slide down into the control center, slide up to check the message, slide left into the main function interface, and slide right into the express center;

button

POWER key

Press short: turn on/off/return to the dial interface.

Long press: on/off

SPORT key

Press short: to highlight the screen/enter the main menu/return to the previous interface.

Press: to enter sports mode.

Watch charging and activation

It can be activated by charging before using the watch for the first time;

The magnetic charger used is attached to the metal contact on the back of the watch, and the other end of the charging cable is connected to the 5V1A USB charging head or computer USB interface.

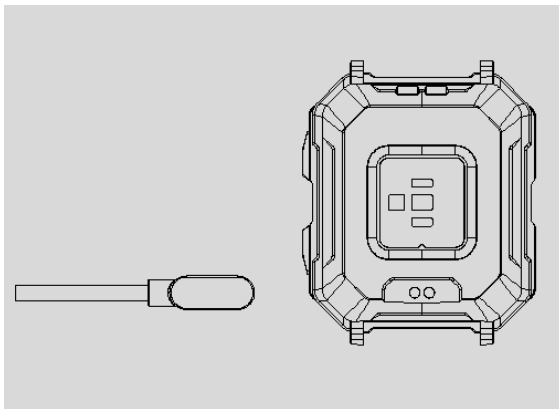

Connect the watch

Open the mobile client to set personal information.



Switch to the device page and click (Add Device)



Click your device in the list of scanned devices.



Complete binding

Go to Watch-Settings-About, check the MAC address of the bracelet, and you can determine your device by the MAC address in the device list;

After the watch is successfully bound, every time the client is opened in the future, the watch will automatically connect with the mobile phone, and the data can be synchronized by pulling down the client data page.



Dial setting

Press and hold the dial interface for 1.5 seconds to switch the dials of different styles in the watch;

After the Bluetooth connection is successful, you can enter APP- Dial Selection-Custom Dial;

After the Bluetooth connection is successful, you can go to APP- Dial Selection-More Dial Selection.

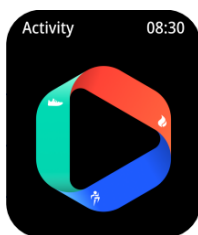

Daily data

You can record the total number of steps in the day, the number of walking steps, calories, exercise duration and other data in each period of the day.

More detailed data can be viewed in the mobile APP;



Sleep monitoring

You can record and display the total sleep duration and the duration of deep sleep and shallow sleep.

More detailed information analysis data records can be viewed on the mobile APP;

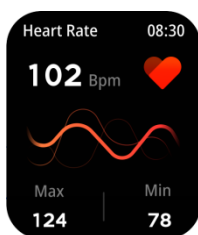

Heart rate monitoring

Before monitoring the heart rate, first make sure that the watch is properly worn on the wrist (the best position is one finger wide above the wrist bone). For the heart rate detection, it is required to wear it tightly so as to avoid light leakage, and then enter the heart rate detection. During the detection process, the wrist is required to remain stationary, and the dynamic heart rate value will be displayed after a few seconds.

Enter the heart rate icon interface to measure the current heart rate value;

Display the current value of the heart rate interface and the heart rate status of each period of the day;

More detailed information analysis and data records can be viewed on the APP side;



take exercise

Click on the exercise interface to enter the exercise interface, which supports walking, running, riding, skipping, badminton, basketball, football, swimming, climbing, tennis, football, golf, yoga, fitness and dancing.

More detailed information analysis and data records can be viewed on the mobile APP;



blood pressure

Before blood pressure monitoring, first make sure that the watch is properly worn on the wrist (the best position is one finger wide above the wrist bone). For blood pressure testing, it is required to wear it tightly to avoid light leakage, and then enter the blood pressure testing. During the testing process, the wrist is required to keep still and wait for the blood pressure value to be displayed.

Enter the blood pressure icon interface to measure the current blood pressure value and the measured data of the last seven times;

More detailed information analysis and data records can be viewed on the APP side;

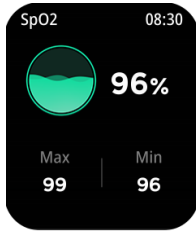

Blood oxygen

Before blood oxygen monitoring, first make sure that the watch is properly worn on the wrist (the best position is one finger wide above the wrist bone). Blood oxygen testing requires that the watch be worn tightly to avoid light leakage and cannot be effectively detected. Then, enter the blood oxygen testing. During the testing process, the wrist is required to keep still and wait for the blood oxygen value to be displayed.

Enter the blood oxygen icon interface to measure the current blood oxygen value;

Display the current value of blood oxygen interface and the measurement data of the last seven times;

More detailed information analysis and data records can be viewed on the APP side;



weather

The weather interface will display the current weather temperature and slide up to display the weather information of the next six days;

The weather information needs to be connected to the APP to get data. If the connection is opened for a long time, the weather information will not be updated;

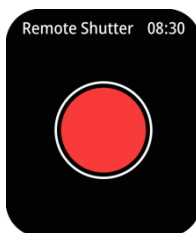

camera

After connecting the mobile APP, the watch can control the mobile phone camera to take pictures;

After turning on the camera on the mobile phone, press and hold on the watch camera control page to trigger the camera shutter of the mobile phone;



Music control

After connecting the mobile APP, the watch can control the music player of the mobile phone; When the mobile phone plays music, you can use the watch to control the mobile phone to play/pause the previous song, the next song and adjust the volume.

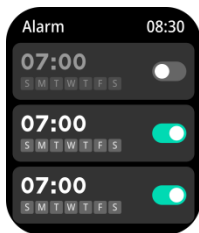

alarm clock

The alarm clock of the watch can be set on the APP side and the watch side, and up to 8 alarms can be set.

After the set time arrives, the watch will display the alarm clock icon and vibrate;

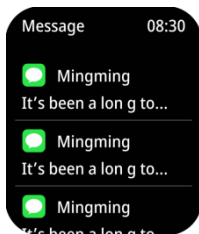

Message push

The watch can receive and display the notification push and incoming call reminder on the mobile phone, and can refuse the call. The push option switch is set in the APP terminal.

The watch message page can store the last 5 message records;



Other functions

Other functions of the watch include:

Breathing exercise, pressure detection, stopwatch, alarm clock, timer, do not disturb mode, power-saving mode, brightness, vibration, factory settings, restart, shutdown, APP download QR code, etc.

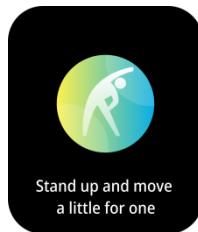

Sedentary reminder

After connecting the APP, turn on the sedentary reminder;

After sitting for 1 hour, the watch will prompt you to get up and walk;

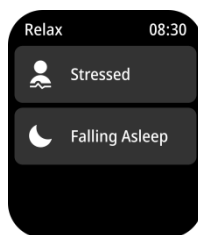

relax

You can choose decompression and sleep aid modes, and adjust your breathing rate by following UI animation to achieve the effect of decompression and sleep aid.

Frequently asked questions and answers

Why can't you wear a watch to take a hot bath?

When bathing, the temperature is relatively high, which will produce a lot of water vapor;

Why can't the bracelet receive the message push?

Android phone settings:

1. Confirm that the message push switch is turned on on the mobile APP;
2. Confirm that the message can be displayed normally on the notification bar of the mobile phone, and the watch message is pushed by obtaining the message of the notification bar of the mobile phone; If there is no message in the notification bar of the mobile phone, the watch will not be able to receive push;

(You need to find the notification settings in the mobile phone settings, and turn on the notification switches of WeChat, QQ, phone, SMS and mobile client)

3. Open the watch's accessibility settings.

(Find the auxiliary function in the phone settings, and open the customer auxiliary function)

settings on the watch side)

Apple mobile phone set

1. Confirm that the message push switch is turned on at the mobile client;
 2. Confirm that the mobile phone message can be displayed normally in the notification bar;
- (You need to find the notification settings in the mobile phone settings, and turn on the notification switches of WeChat, QQ, phone, SMS and mobile client)

FCC Warning: This equipment has been tested and found to comply with the limits for a Class B digital device, pursuant to part 15 of the FCC Rules. These limits are designed to provide reasonable protection against harmful interference in a residential installation. This equipment generates, uses and can radiate radio frequency energy and, if not installed and used in accordance with the instructions, may cause harmful interference to radio communications. However, there is no guarantee that interference will not occur in a particular installation. If this equipment does cause harmful interference to radio or television reception, which can be determined by turning the equipment off and on, the user is encouraged to try to correct the interference by one or more of the following measures:

- Reorient or relocate the receiving antenna.
- Increase the separation between the equipment and receiver.
- Connect the equipment into an outlet on a circuit different from that to which the receiver is connected.
- Consult the dealer or an experienced radio/TV technician for help.

Caution: Any changes or modifications to this device not explicitly approved by manufacturer could void your authority to operate this equipment.

This device complies with part 15 of the FCC Rules. Operation is subject to the following two conditions: (1) This device may not cause harmful interference, and (2) this device must accept any interference received, including interference that may cause undesired operation.

The device has been evaluated to meet general RF exposure requirement. The device can be used in portable exposure condition without restriction.