



FCC TEST REPORT

FCC ID:2A66J-Y10

Report Number : ZKT-2205243463E

Date of Test May. 25, 2022 to May. 31, 2022

Date of issue : May. 31, 2022

Total number of pages 20

Test Result : PASS

Testing Laboratory..... : **Shenzhen ZKT Technology Co., Ltd.**

Address : 1/F, No. 101, Building B, No. 6, Tangwei Community Industrial Avenue, Fuhai Street, Bao'an District, Shenzhen, China

Applicant's name : **YINUOLINK CO.,LTD**

Address : 301,Bldg 6, Gaoxinjian Industrial Park, Fuyuan 1st Road, Heping, Fuhai, Bao'an, Shenzhen, China

Manufacturer's name : **YINUOLINK CO.,LTD**

Address : 301,Bldg 6, Gaoxinjian Industrial Park, Fuyuan 1st Road, Heping, Fuhai, Bao'an, Shenzhen, China

Test specification:

Standard..... : FCC CFR Title 47 Part 15 Subpart B

Test procedure..... : /

Non-standard test method : N/A

Test Report Form No. : TRF-EL-107_V0

Test Report Form(s) Originator : ZKT Testing

Master TRF : Dated: 2020-01-06

This device described above has been tested by ZKT, and the test results show that the equipment under test (EUT) is in compliance with the FCC requirements. And it is applicable only to the tested sample identified in the report.

This report shall not be reproduced except in full, without the written approval of ZKT, this document may be altered or revised by ZKT, personal only, and shall be noted in the revision of the document.

Product name : **AX5400 Triple Band WiFi 6E PCIe Adapter**

Trademark : **YINUO-LINK[®]**

Model/Type reference : Y10

Ratings..... : Input: DC 12V



Testing procedure and testing location:

Testing Laboratory.....: **Shenzhen ZKT Technology Co., Ltd.**

Address.....: 1/F, No. 101, Building B, No. 6, Tangwei Community Industrial Avenue, Fuhai Street, Bao'an District, Shenzhen, China

Tested by (name + signature): **Alen He**

Reviewer (name + signature).....: **Joe Liu**

Approved (name + signature): **Lake Xie**



TABLE OF CONTENTS

1. VERSION	4
2. TEST SUMMARY	5
2.1 TEST FACILITY	6
2.2 MEASUREMENT UNCERTAINTY	6
3. GENERAL INFORMATION	7
3.1 GENERAL DESCRIPTION OF EUT	7
3.2 Test mode	7
3.3 Block Diagram of EUT Configuration	7
3.4 Test Conditions	7
3.5 Description Of Support Units (Conducted Mode)	8
3.6 EQUIPMENTS LIST FOR ALL TEST ITEMS	8
4. CONDUCTED EMISSION TEST	10
4.1 CONDUCTED EMISSION MEASUREMENT	10
4.1.1 POWER LINE CONDUCTED EMISSION Limits	10
4.1.2 TEST PROCEDURE	10
4.1.3 DEVIATION FROM TEST STANDARD	10
4.1.4 TEST SETUP	11
4.1.5 EUT OPERATING CONDITIONS	11
4.1.6 Test Result	12
5. RADIATED EMISSION MEASUREMENT	14
5.1 Radiated Emission Limits	14
5.2 Anechoic Chamber Test Setup Diagram	14
5.3 Test Procedure	15
5.4 DEVIATION FROM TEST STANDARD	15
5.5 Test Result	16
6. TEST SETUP PHOTO	20
7. EUT CONSTRUCTIONAL DETAILS	20



1. VERSION

Report No.	Version	Description	Approved
ZKT-2205243463E	Rev.01	Initial issue of report	May. 31, 2022



2. TEST SUMMARY

Test Item	Section in CFR 47	Result
AC Power Line Conducted Emission	15.107	Pass
Radiated Emission	15.109	Pass

NOTE:

(1) "N/A" denotes test is not applicable in this Test Report



2.1 TEST FACILITY

Shenzhen ZKT Technology Co., Ltd.
Add. : 1/F, No. 101, Building B, No. 6, Tangwei Community Industrial Avenue, Fuhai Street,
Bao'an District, Shenzhen, China

FCC Test Firm Registration Number: 692225
Designation Number: CN1299
IC Registered No.: 27033

2.2 MEASUREMENT UNCERTAINTY

The reported uncertainty of measurement $y \pm U$, where expanded uncertainty U is based on a standard uncertainty multiplied by a coverage factor of $k=2$, providing a level of confidence of approximately 95 %.

No.	Item	Uncertainty
1	3m chamber Radiated spurious emission(9KHz-30MHz)	U=4.5dB
2	3m chamber Radiated spurious emission(30MHz-1GHz)	U=4.8dB
3	3m chamber Radiated spurious emission(1GHz-6GHz)	U=4.9dB
4	3m chamber Radiated spurious emission(6GHz-40GHz)	U=5.0dB
5	Conducted disturbance	U=3.2dB
6	RF Band Edge	U=1.68dB
7	RF power conducted	U=1.86dB
8	RF conducted Spurious Emission	U=2.2dB
9	RF Occupied Bandwidth	U=1.8dB
10	RF Power Spectral Density	U=1.75dB
11	humidity uncertainty	U=5.3%
12	Temperature uncertainty	U=0.59°C



3. GENERAL INFORMATION

3.1 GENERAL DESCRIPTION OF EUT

Product Name:	AX5400 Triple Band WiFi 6E PCIe Adapter				
Model No.:	Y10				
Model Difference:	N/A				
Serial No.:	N/A				
Hardware version:	H1.0				
Software version:	S1.0				
Operation frequency:	BT: 2402-2480MHz BLE: 2402-2480MHz 2.4GWIFI: 2412-2472MHz 2422-2462MHz 5GWIFI: 5180-5250MHz 5250-5320MHz 5500-5720MHz 5720-5825MHz				
Antenna Type:	Dipole Antenna				
Antenna gain:	2.4GHz	5.2GHz	5.3GHz	5.6GHz	5.8GHz
	2.89dBi	2.92dBi	3.19dBi	4.41dBi	4.22dBi
Power supply:	Input: DC 12V				

3.2 Test mode

The EUT Link WiFi network communication.

3.3 Block Diagram of EUT Configuration

Conducted Emission

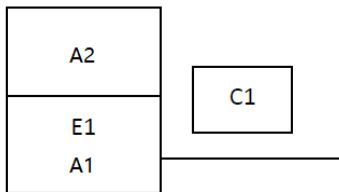

Radiated Emission

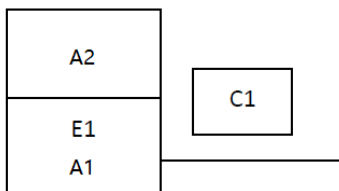

3.4 Test Conditions

Temperature: 23~26°C

Relative Humidity: 54~63 %



3.5 Description Of Support Units (Conducted Mode)

The EUT has been tested as an independent unit together with other necessary accessories or support units. The following support units or accessories were used to form a representative test configuration during the tests.

Item	Equipment	Mfr/Brand	Model/Type No.	Series No.	Note
E1	AX5400 Triple Band WiFi 6E PCIe Adapter	TINUO-LINK [®]	Y10	N/A	EUT
A1	Computer	ACER	DL01	N/A	Auxiliary
A2	LED Momitor	ACER	DL02	N/A	Auxiliary

Item	Shielded Type	Ferrite Core	Length	Note
C1	NO	NO	1.2M	AC cable unshielded

Note:

- (1) The support equipment was authorized by Declaration of Confirmation.
- (2) For detachable type I/O cable should be specified the length in cm in 『Length』 column.
- (3) “YES” is means “shielded” “with core”; “NO” is means “unshielded” “without core”.

3.6 EQUIPMENTS LIST FOR ALL TEST ITEMS



Radiation Test equipment

Item	Equipment	Manufacturer	Type No.	Serial No.	Last calibration	Calibrated until
1	Spectrum Analyzer (9kHz-26.5GHz)	KEYSIGHT	9020A	MY45109572	Sep. 22, 2021	Sep. 21, 2022
2	Spectrum Analyzer (1GHz-40GHz)	Agilent	E4446A	100363	Sep. 22, 2021	Sep. 21, 2022
3	Test Receiver (9kHz-7GHz)	R&S	ESC17	101169	Sep. 22, 2021	Sep. 21, 2022
4	Bilog Antenna (30MHz-1400MHz)	Schwarzbeck	VULB9168	00877	Sep. 22, 2021	Sep. 21, 2022
5	Horn Antenna (1GHz-18GHz)	SCHWARZBECK	BBHA9120D	1541	Sep. 22, 2021	Sep. 21, 2022
6	Horn Antenna (18GHz-40GHz)	A.H. System	SAS-574	588	Sep. 22, 2021	Sep. 21, 2022
7	Amplifier (30-1000MHz)	EM Electronics	EM330 Amplifier	N/A	Sep. 22, 2021	Sep. 21, 2022
8	Amplifier (1GHz-40GHz)	QUANJUDA	DLE-161	097	Sep. 22, 2021	Sep. 21, 2022
9	Loop Antenna (9kHz-30MHz)	SCHWARZBECK	FMZB1519B	014	Sep. 22, 2021	Sep. 21, 2022
10	RF cables1 (9kHz-30MHz)	N/A	9kHz-30MHz	N/A	Sep. 22, 2021	Sep. 21, 2022
11	RF cables2 (30MHz-1GHz)	N/A	30MHz-1GHz	N/A	Sep. 22, 2021	Sep. 21, 2022
12	RF cables3 (1GHz-40GHz)	N/A	1GHz-40GHz	N/A	Sep. 22, 2021	Sep. 21, 2022
13	CMW500 Test	R&S	CMW500	106504	Sep. 22, 2021	Sep. 21, 2022
14	ESG Signal Generator	Agilent	E4421B	GB40051203	Sep. 22, 2021	Sep. 21, 2022
15	Signal Generator	Agilent	N5182A	MY47420215	Sep. 22, 2021	Sep. 21, 2022
16	D.C. Power Supply	LongWei	TPR-6405D	\	\	\
17	Software	Frad	EZ-EMC	FA-03A2 RE	\	\

Conduction Test equipment

Item	Kind of Equipment	Manufacturer	Type No.	Serial No.	Last calibration	Calibrated until
1	LISN	R&S	ENV216	101471	Sep. 22, 2021	Sep. 21, 2022
2	LISN	CYBERTEK	EM5040A	E1850400149	Sep. 22, 2021	Sep. 21, 2022
3	Test Cable	N/A	C01	N/A	Sep. 22, 2021	Sep. 21, 2022
4	Test Cable	N/A	C02	N/A	Sep. 22, 2021	Sep. 21, 2022
5	EMI Test Receiver	R&S	ESRP3	101946	Sep. 22, 2021	Sep. 21, 2022
6	Absorbing Clamp	DZ	ZN23201	N/A	Sep. 22, 2021	Sep. 21, 2022



4. CONDUCTED EMISSION TEST

4.1 CONDUCTED EMISSION MEASUREMENT

Test Requirement:	FCC Part15 C Section 15.107
Test Method:	ANSI C63.4:2014
Test Frequency Range:	150KHz to 30MHz
Receiver setup:	RBW=9KHz, VBW=30KHz, Sweep time=auto

4.1.1 POWER LINE CONDUCTED EMISSION Limits

FREQUENCY (MHz)	Limit (dBuV)		Standard
	Quas -peak	Average	
0.15 -0.5	66 - 56 *	56 - 46 *	FCC
0.50 -5.0	56.00	46.00	FCC
5.0 -30.0	60.00	50.00	FCC

Note:

(1) *Decreases with the logarithm of the frequency.

4.1.2 TEST PROCEDURE

- The EUT was placed 0.8 meters from the horizontal ground plane with EUT being connected to the power mains through a line impedance stabilization network (LISN). All other support equipments powered from additional LISN(s). The LISN provide 50 Ohm/ 50uH of coupling impedance for the measuring instrument.
- Interconnecting cables that hang closer than 40 cm to the ground plane shall be folded back and forth in the center forming a bundle 30 to 40 cm long.
- I/O cables that are not connected to a peripheral shall be bundled in the center. The end of the cable may be terminated, if required, using the correct terminating impedance. The overall length shall not exceed 1 m.
- LISN at least 80 cm from nearest part of EUT chassis.
- For the actual test configuration, please refer to the related Item –EUT Test Photos.

4.1.3 DEVIATION FROM TEST STANDARD

No deviation



4.1.4 TEST SETUP

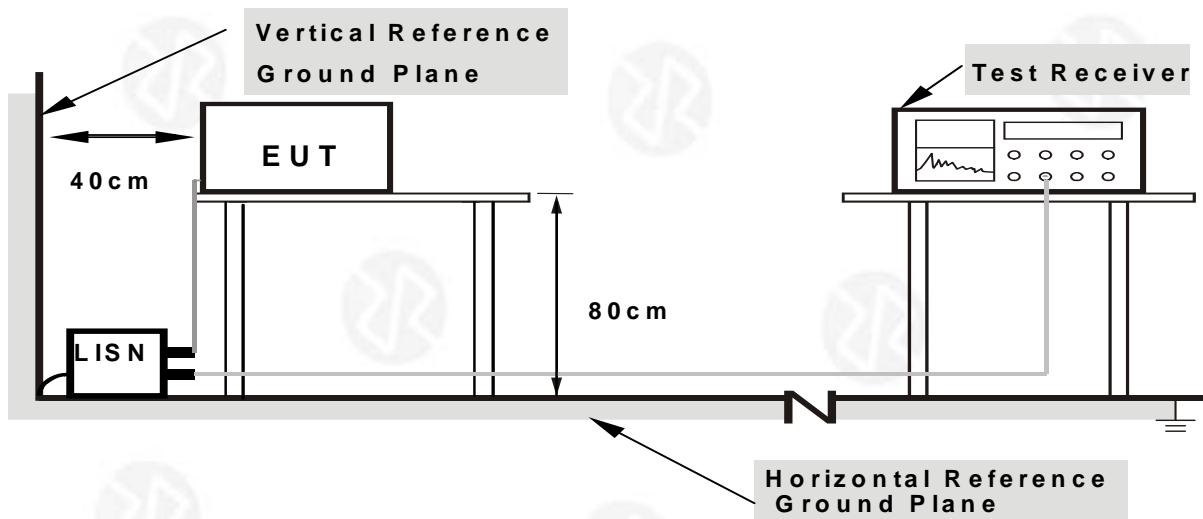

- Note:**
- 1.Support units were connected to second LISN.
 - 2.Both of LISNs (AMN) are 80 cm from EUT and at least 80 cm from other units and other metal planes

4.1.5 EUT OPERATING CONDITIONS

The EUT was configured for testing in a typical fashion (as a customer would normally use it). The EUT has been programmed to continuously transmit during test. This operating condition was tested and used to collect the included data.



4.1.6 Test Result

Temperature:	26°C	Relative Humidity:	54%
Pressure:	101kPa	Phase :	L
Test Voltage :	AC 120V/60Hz		

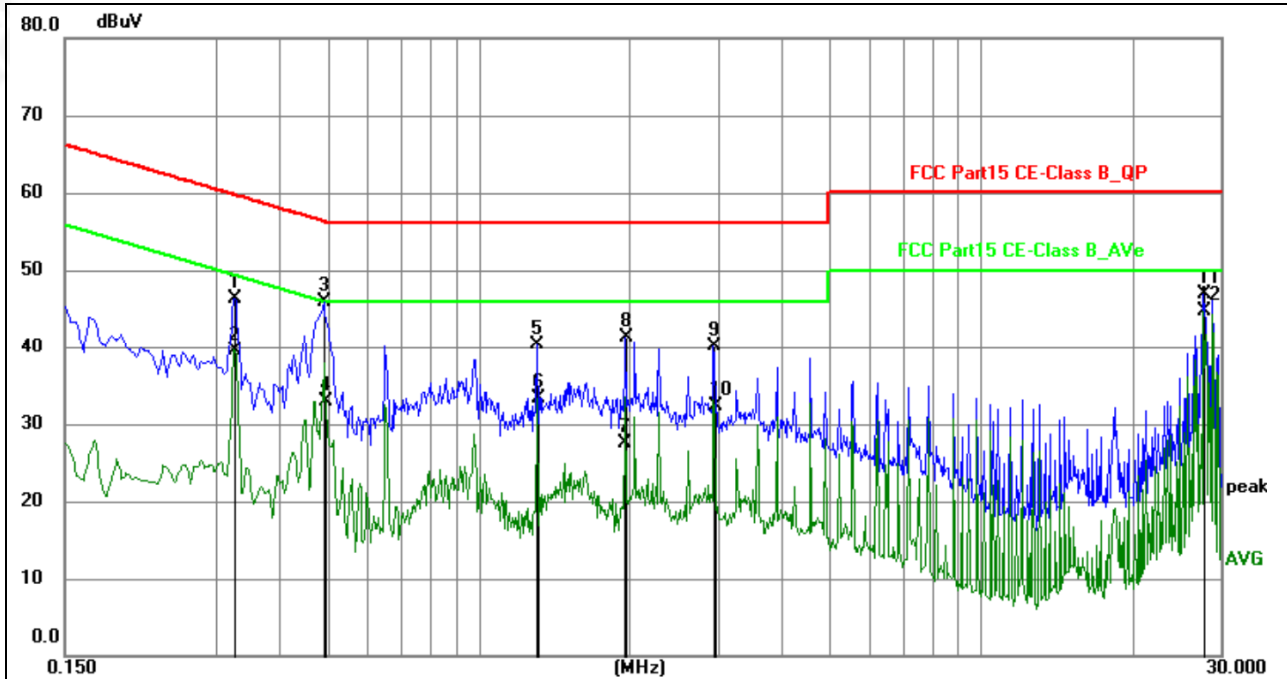

No.	Frequency (MHz)	Reading (dBuV)	Factor (dB)	Level (dBuV)	Limit (dBuV)	Margin (dB)	Detector	P/F	Remark
1	0.3255	34.90	11.34	46.24	59.57	-13.33	QP	P	
2	0.3268	28.22	11.34	39.56	49.53	-9.97	AVG	P	
3	0.4920	35.32	10.58	45.90	56.13	-10.23	QP	P	
4	0.4967	22.29	10.56	32.85	46.06	-13.21	AVG	P	
5	1.3065	30.01	10.36	40.37	56.00	-15.63	QP	P	
6	1.3110	22.99	10.36	33.35	46.00	-12.65	AVG	P	
7	1.9590	17.28	10.20	27.48	46.00	-18.52	AVG	P	
8	1.9635	31.13	10.20	41.33	56.00	-14.67	QP	P	
9	2.9445	30.16	9.95	40.11	56.00	-15.89	QP	P	
10	2.9490	22.28	9.95	32.23	46.00	-13.77	AVG	P	
11	27.8205	36.98	9.94	46.92	60.00	-13.08	QP	P	
12	27.8205	34.83	9.94	44.77	50.00	-5.23	AVG	P	

Notes:

1. An initial pre-scan was performed on the line and neutral lines with peak detector.
2. Quasi-Peak and Average measurement were performed at the frequencies with maximized peak emission.
3. Measurement Level = Reading level + Correct Factor



Temperature:	26°C	Relative Humidity:	54%
Pressure:	101kPa	Phase :	N
Test Voltage :	AC 120V/60Hz		

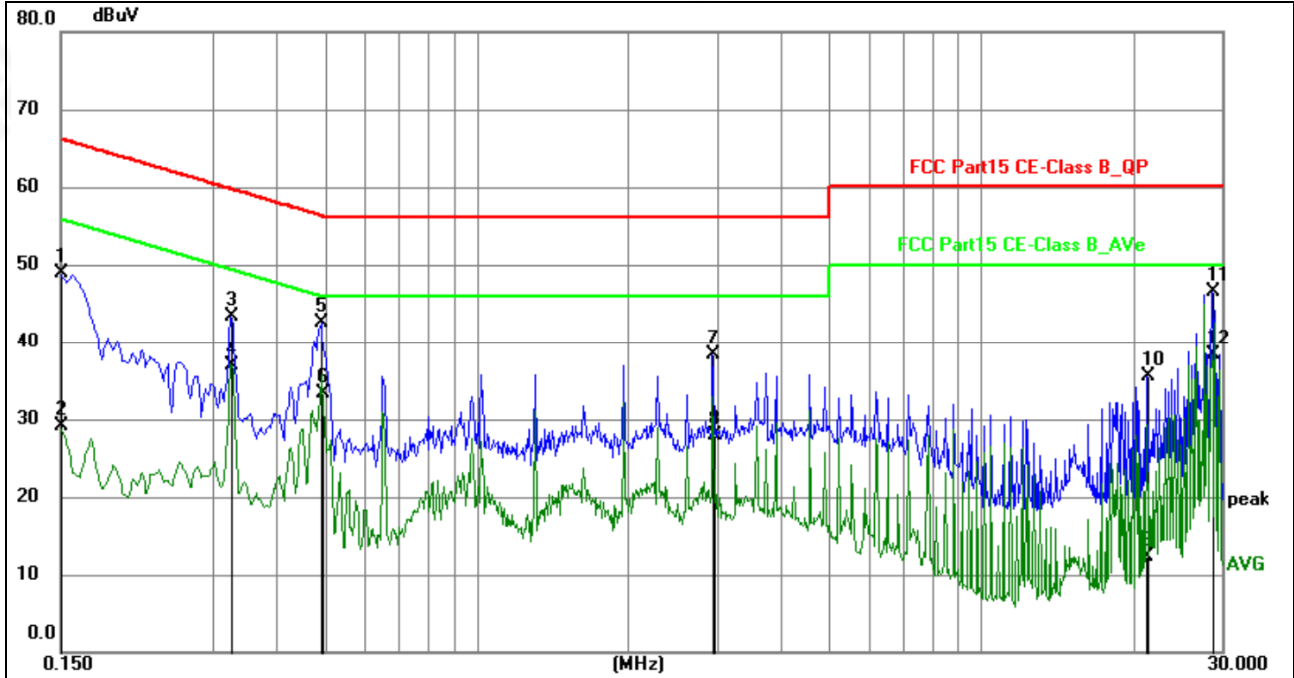

No.	Frequency (MHz)	Reading (dBuV)	Factor (dB)	Level (dBuV)	Limit (dBuV)	Margin (dB)	Detector	P/F	Remark
1	0.1500	35.89	13.01	48.90	66.00	-17.10	QP	P	
2	0.1500	16.08	13.01	29.09	56.00	-26.91	AVG	P	
3	0.3255	32.04	11.34	43.38	59.57	-16.19	QP	P	
4	0.3268	25.63	11.34	36.97	49.53	-12.56	AVG	P	
5	0.4920	31.98	10.58	42.56	56.13	-13.57	QP	P	
6	0.4965	22.84	10.56	33.40	46.06	-12.66	AVG	P	
7	2.9445	28.36	9.95	38.31	56.00	-17.69	QP	P	
8	2.9490	18.00	9.95	27.95	46.00	-18.05	AVG	P	
9	21.2595	2.48	9.87	12.35	50.00	-37.65	AVG	P	
10	21.2685	25.72	9.87	35.59	60.00	-24.41	QP	P	
11	28.6530	36.54	9.95	46.49	60.00	-13.51	QP	P	
12	28.6530	28.37	9.95	38.32	50.00	-11.68	AVG	P	

Notes:

1. An initial pre-scan was performed on the line and neutral lines with peak detector.
2. Quasi-Peak and Average measurement were performed at the frequencies with maximized peak emission.
3. Measurement Level = Reading level + Correct Factor



5. RADIATED EMISSION MEASUREMENT

Test Requirement:	FCC Part15 C Section 15.109				
Test Method:	ANSI C63.4:2014				
Test Frequency Range:	30MHz to 40GHz				
Test site:	Measurement Distance: 3m				
Receiver setup:	Frequency	Detector	RBW	VBW	Value
	9KHz-150KHz	Quasi-peak	200Hz	600Hz	Quasi-peak
	150KHz-30MHz	Quasi-peak	9KHz	30KHz	Quasi-peak
	30MHz-1GHz	Quasi-peak	100KHz	300KHz	Quasi-peak
	Above 1GHz	Peak	1MHz	3MHz	Peak
		Peak	1MHz	10Hz	Average

5.1 Radiated Emission Limits

Limits for frequency Above 30MHz

Frequency	Limit (dBuV/m @3m)	Remark
30MHz-88MHz	40.00	Quasi-peak Value
88MHz-216MHz	43.50	Quasi-peak Value
216MHz-960MHz	46.00	Quasi-peak Value
960MHz-1GHz	54.00	Quasi-peak Value
Above 1GHz	54.00	Average Value
	74.00	Peak Value

5.2 Anechoic Chamber Test Setup Diagram



(A) Radiated Emission Test-Up Frequency 30MHz~1GHz

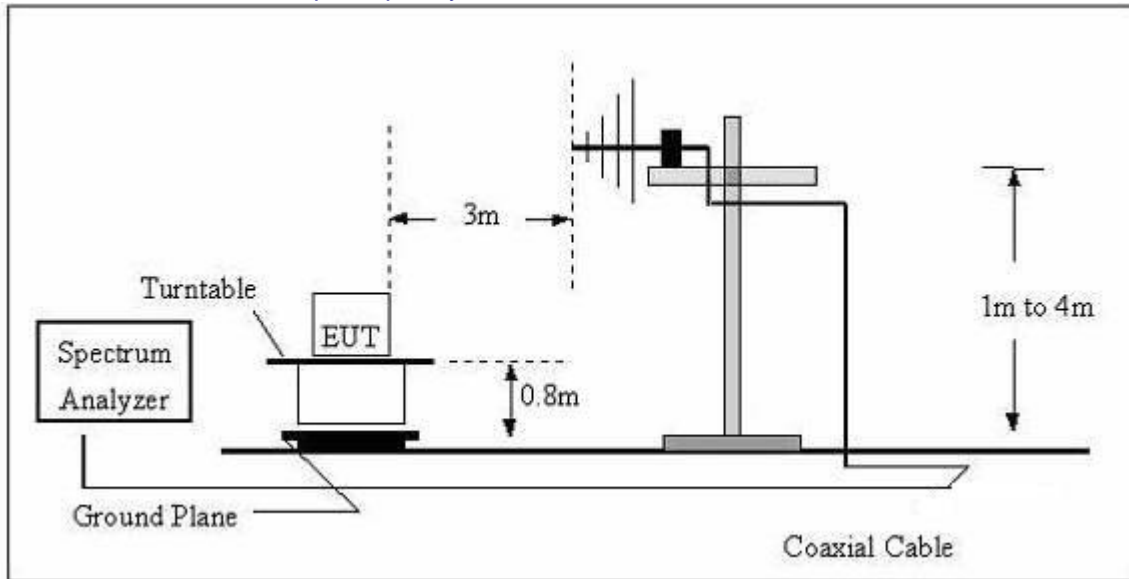

(B) Radiated Emission Test-Up Frequency Above 1GHz

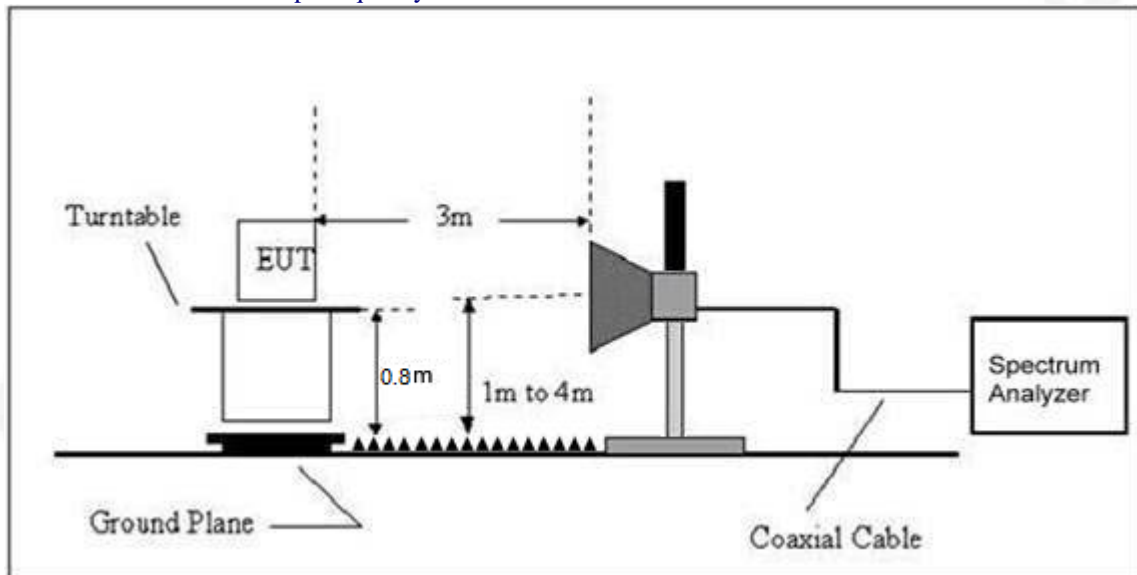

The radiated emission tests were performed in the 3 meters chamber test site, using the setup accordance with the ANSI C63.4-2014. The specification used was the FCC 15.109 limits.

5.3 Test Procedure

The EUT is placed on a turn table which is 0.8 meter above ground. The turn table can rotate 360 degrees to determine the position of the maximum emission level. The EUT is set 3 meters away from the receiving antenna which is mounted on a antenna tower. The antenna can move up and down between 1 to 4 meters to find out the maximum emission level. Broadband antenna (calibrated by dipole antenna) are used as a receiving antenna. Both horizontal and vertical polarization of the antenna are set on measurement.

5.4 DEVIATION FROM TEST STANDARD

No deviation



5.5 Test Result

30MHz-1GHz

Temperature:	26°C	Relative Humidity:	54%
Pressure:	101 kPa	Polarization:	Horizontal
Test Voltage:	AC 120V/60Hz		

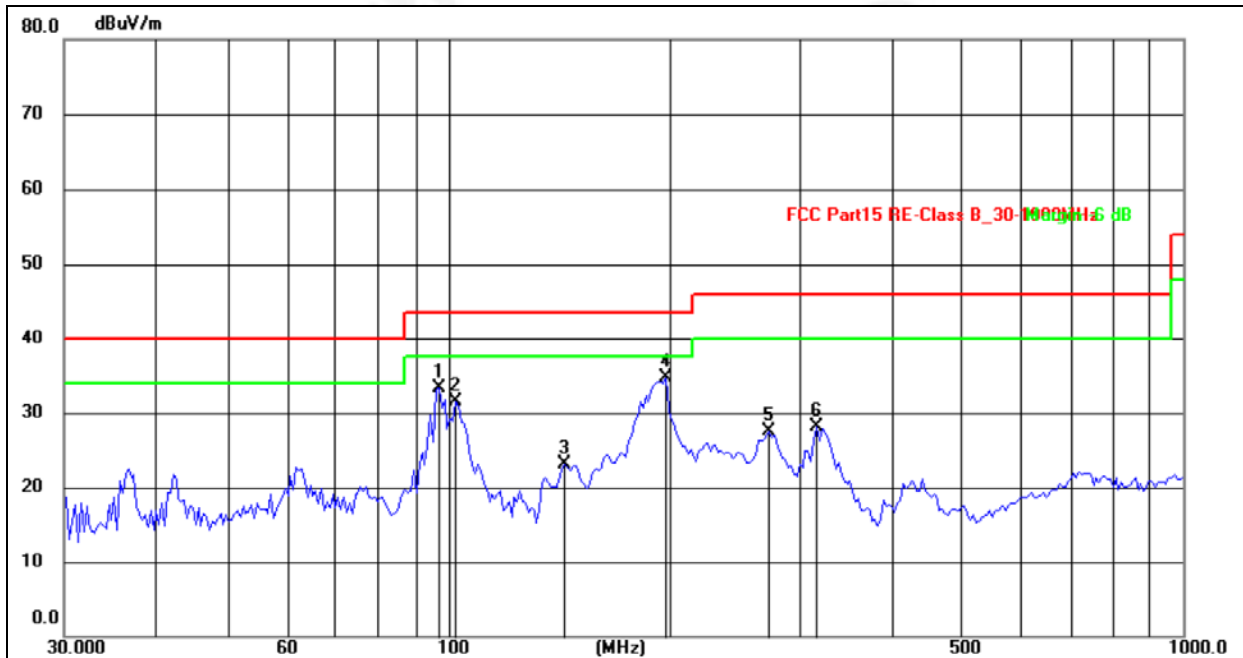

No.	Frequency (MHz)	Reading (dBuV)	Factor (dB/m)	Level (dBuV/m)	Limit (dBuV/m)	Margin (dB)	Detector
1	97.1148	53.23	-19.93	33.30	43.50	-10.20	QP
2	102.3596	51.20	-19.70	31.50	43.50	-12.00	QP
3	144.0819	40.32	-17.23	23.09	43.50	-20.41	QP
4	197.5461	54.37	-19.65	34.72	43.50	-8.78	QP
5	273.2340	43.96	-16.48	27.48	46.00	-18.52	QP
6	317.1445	47.09	-18.92	28.17	46.00	-17.83	QP



Temperature:	26°C	Relative Humidity:	54%
Pressure:	101kPa	Polarization:	Vertical
Test Voltage:	AC 120V/60Hz		

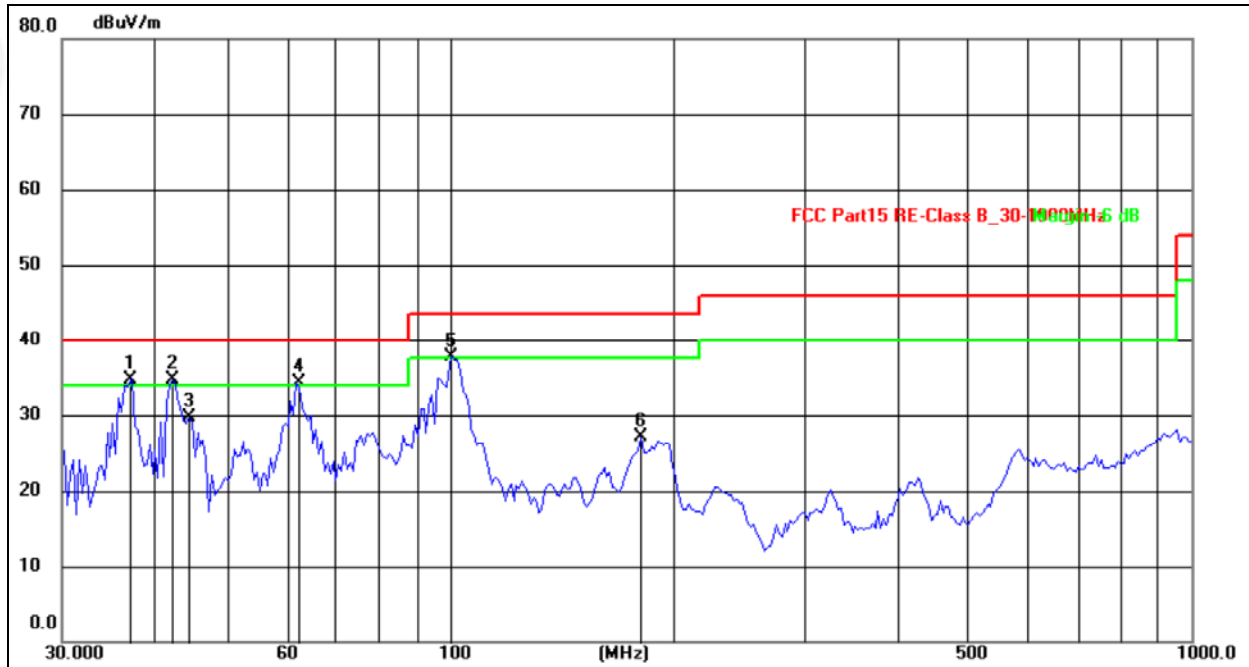

No.	Frequency (MHz)	Reading (dBuV)	Factor (dB/m)	Level (dBuV/m)	Limit (dBuV/m)	Margin (dB)	Detector
1	37.0248	52.01	-17.31	34.70	40.00	-5.30	QP
2	42.2281	51.66	-16.96	34.70	40.00	-5.30	QP
3	44.5087	46.78	-17.06	29.72	40.00	-10.28	QP
4	62.1039	52.74	-18.53	34.21	40.00	-5.79	QP
5	100.5806	58.97	-21.23	37.74	43.50	-5.76	QP
6	180.9658	47.88	-20.69	27.19	43.50	-16.31	QP

Remarks:

1. Final Level = Receiver Read level + Antenna Factor + Cable Loss – Preamplifier Factor
2. The emission levels of other frequencies are very lower than the limit and not show in test report.



Above 1GHz

Temperature:	26°C	Relative Humidity:	54%
Pressure:	101 kPa	Polarization:	Horizontal
Test Voltage:	AC 120V/60Hz		

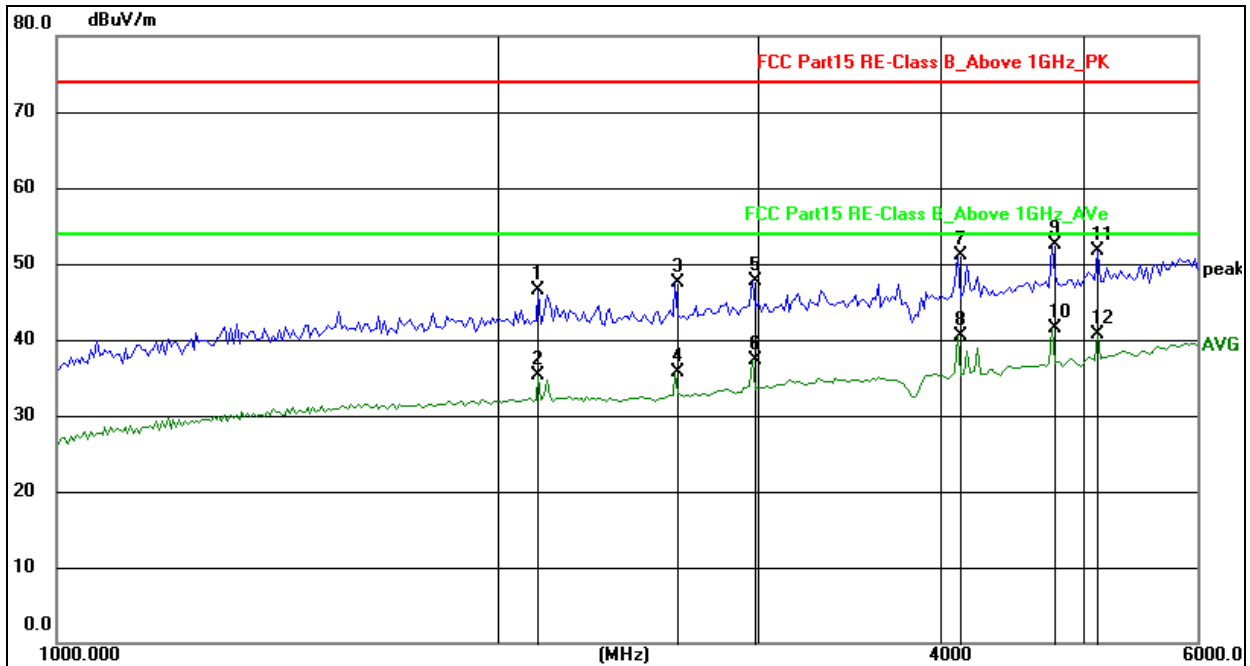

No.	Frequency (MHz)	Reading (dBuV)	Factor (dB/m)	Level (dBuV/m)	Limit (dBuV/m)	Margin (dB)	Detector
1	2131.910	46.82	-0.33	46.49	74.00	-27.51	QP
2	2131.910	35.72	-0.33	35.39	54.00	-18.61	AVG
3	2643.304	47.11	0.48	47.59	74.00	-26.41	QP
4	2643.304	35.14	0.48	35.62	54.00	-18.38	AVG
5	2983.131	46.70	1.02	47.72	74.00	-26.28	QP
6	2983.131	36.22	1.02	37.24	54.00	-16.76	AVG
7	4118.504	48.33	2.81	51.14	74.00	-22.86	QP
8	4118.504	37.69	2.81	40.50	54.00	-13.50	AVG
9	4774.600	48.66	3.85	52.51	74.00	-21.49	QP
10	4774.600	37.70	3.85	41.55	54.00	-12.45	AVG
11	5129.358	47.32	4.41	51.73	74.00	-22.27	QP
12	5129.358	36.33	4.41	40.74	54.00	-13.26	AVG



Temperature:	26°C	Relative Humidity:	54%
Pressure:	101kPa	Polarization:	Vertical
Test Voltage:	AC 120V/60Hz		

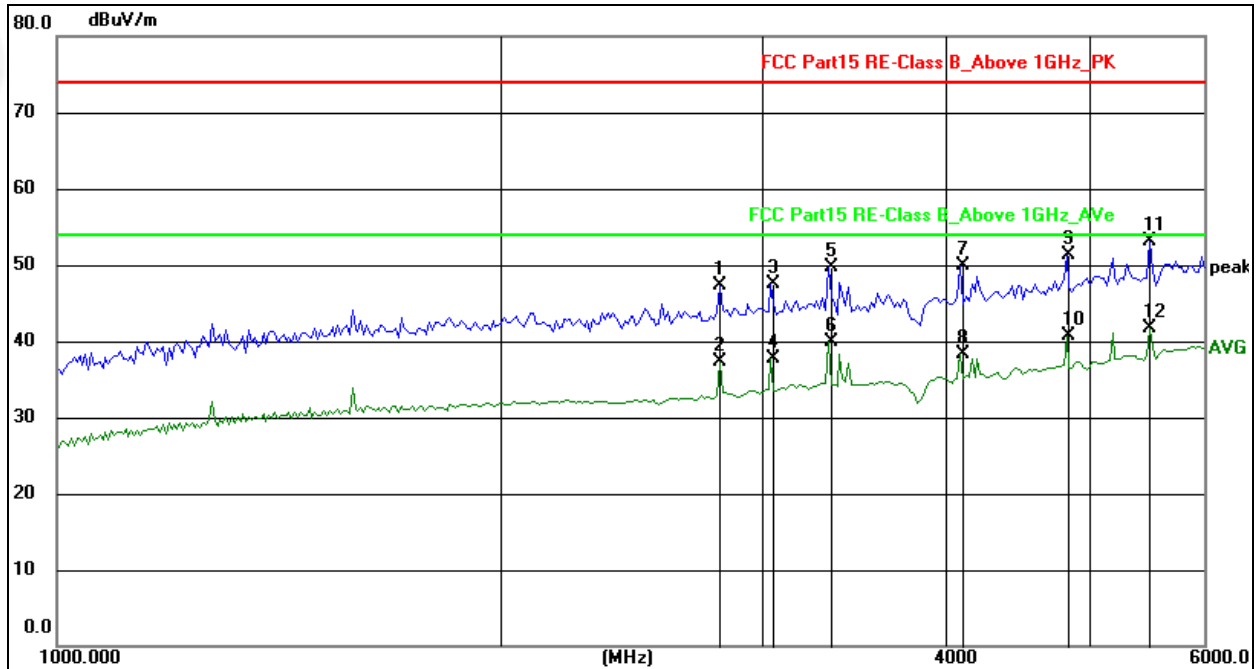

No.	Frequency (MHz)	Reading (dBuV)	Factor (dB/m)	Level (dBuV/m)	Limit (dBuV/m)	Margin (dB)	Detector
1	2814.377	46.50	0.75	47.25	74.00	-26.75	QP
2	2814.377	36.52	0.75	37.27	54.00	-16.73	AVG
3	3050.698	46.43	1.13	47.56	74.00	-26.44	QP
4	3050.698	36.58	1.13	37.71	54.00	-16.29	AVG
5	3336.620	48.07	1.58	49.65	74.00	-24.35	QP
6	3336.620	38.38	1.58	39.96	54.00	-14.04	AVG
7	4100.097	47.21	2.78	49.99	74.00	-24.01	QP
8	4100.097	35.61	2.78	38.39	54.00	-15.61	AVG
9	4839.195	47.32	3.95	51.27	74.00	-22.73	QP
10	4839.195	36.66	3.95	40.61	54.00	-13.39	AVG
11	5510.475	48.18	5.00	53.18	74.00	-20.82	QP
12	5510.475	36.67	5.00	41.67	54.00	-12.33	AVG

Remarks:

1. Final Level = Receiver Read level + Antenna Factor + Cable Loss – Preamplifier Factor
2. The emission levels of other frequencies are very lower than the limit and not show in test report.
3. The emission from 6GHz to 40GHz was pre-tested and found the result was 20dB lower than the limit, and the test result no need to reported.



6. TEST SETUP PHOTO

Reference to the appendix I for details.

7. EUT CONSTRUCTIONAL DETAILS

Reference to the appendix II for details.

***** END OF REPORT *****