

东莞市金赞智能科技有限公司

DONGGUAN KIMCHEN INDUSTRY INTL LIMITED



DONGGUAN KIMCHEN INDUSTRY INTL LIMITED

SPECIFICATION FOR APPROVAL

Shenzhen Utopia-Originality Technology Co., Ltd

CUSTOMER: _____

520-W0020-0003

CUST P/N: _____

K C P/N: _____

15.4*21*0.08*24P*12TS*15mm

D E S E : _____

2023. 3. 14

D A T E : _____

A. 0

VERSION : _____

ACCEPTANCE STAMP

PREPARED BY	MERCHANDISER	ENGINEER CHECKED BY	PRODUCTION CHECKDED BY	APPROVED BY
Yunfan Wang				

Address: No2 Xisha Road Shijie Guangdong 523290 Guangdong China

FileNo: KC-JZ-09-008

东莞市金赞智能科技有限公司

DONGGUAN KIMCHEN INDUSTRY INTL LIMITED

Specification

CUST P/N

KC P/N

20.5*40*0.08*24P*2P*10TS*80

Version Change History

Reversion	Before Change	DESCRIPTION(Content Or Reason For Change)	Date	Reviser
A.0	--	Initial Release	2023/3/10	Yunfan Wang

PREPARED BY

ENGINEER CHECKED BY

PRODUCTION CHECKED BY

Yunfan Wang

胡志军

王赞

Address: No2 Xisha Road Shijie Guangdong 523290 Guangdong China

FileNo: KC-JZ-09-008

东莞市金赞智能科技有限公司

DONGGUAN KIMCHEN INDUSTRY INTL LIMITED

			CUST P/N		
Specification			KC P/N	20.5*40*0.08*24P*2P*10TS*80	

1. OVERALL DIMENSIONS OF PRODUCTS):

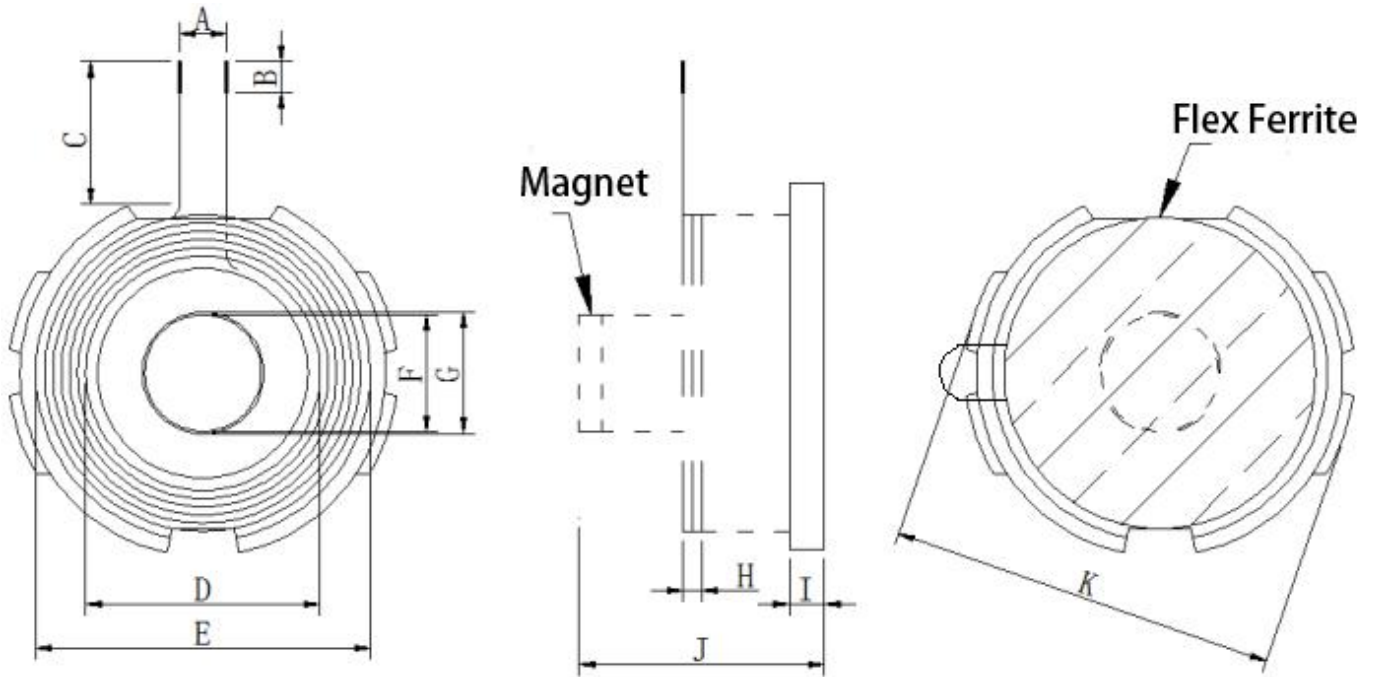

Unit:mm

A	B	C	D	E	F	G	H	I	J	K
2±1	2±1	15±1	15.4±0.5	21MAX	7.5MAX	7.8±0.5	1.12±0.1	2.25MAX	3.0MAX	25±0.5

Turns	Wire Diameter	Winding Direction	Lead wire Intersect Yes/Not	Coil Positive/Reversely Paste
12	0.08*24 strand Litz Wire	counter-clockwise	Yes	Reversely pasted

PREPARED BY	ENGINEER CHECKED BY	PRODUCTION CHECKED BY
Yunfan Wang	胡志军	王运凡

Address: No2 Xisha Road Shijie Guangdong 523290 Guangdong China

FileNo: KC-JZ-09-008

东莞市金赞智能科技有限公司

DONGGUAN KIMCHEN INDUSTRY INTL LIMITED

Specification	CUST P/N	
	KC P/N	20.5*40*0.08*24P*2P*10TS*80

2. ELECTRICAL CHARACTERISTICS :

TEMPERATURE: 25 ± 10°C, RELATIVE HUMIDITY: 65 ± 10%

NO.	ITEM	TERMINAL	INDUCTANCE	TEST FREQUENCY	TEST EQUIPMENTS
1	IND	S-F	Coil 3.9 uH ± 10%	1kHz/V	LCZ METER 1062
2	IND	S-F	Coil+Ferrite 6.4uH ± 10%	1kHz/V	LCZ METER 1062

3. BILL OF MATERIALS :

NO.	Material name	Description	Material Code	Vendor code
1	Wire	0.08*24 strand Litz wire	JX-2U-F-0009	HY
2	Hard Ferrite	G25*7.8*2.25H (Groove: 5.2*2.0H Groove: 8.5*2.0H)	GCP-Y-0003	HNLC
3	Flex Ferrite	20*0.3H	GCP-T-00026	LZ
4	3M Tape	19*0.05H		
5	Galvanized Magnet	N48 7.5*2.2H GS3200	E7202W	YYC

PREPARED BY

ENGINEER CHECKED BY

PRODUCTION CHECKED BY

Yunfan Wang

胡志军

王云帆

Address: No2 Xisha Road Shijie Guangdong 523290 Guangdong China

File No: KC-JZ-09-008