

**SPECIFICATION FOR APPROVAL**

CUSTOMER:	USA W-DODD INC
CUST P/N:	W28
FINE P/N:	<b>G50-6.5uH 0.07*100P*10TS</b>
DESC:	<b>Φ 50MMX5.0MMX0.8MM</b>
DATE:	<b>2023/07/01</b>
Version:	<b>A.0</b>

Manufacturer : Shenzhen Songdao Technology Co., Ltd

Factory address: Floor 8, Building 2, Sanjia High tech Industrial Park, 123 Junfa  
Third Road, Dongkeng Town, Dongguan City

TEL: 13728755750

E-mail: 506388681@QQ.com



# SPECIFICATION

DESC	Φ 20.5x41-6.5uH-0.07x100-28mm	Rev: A.0	CUST:	<b>XXX</b>
			CUST P/N:	

1. DIMENSION:(mm)

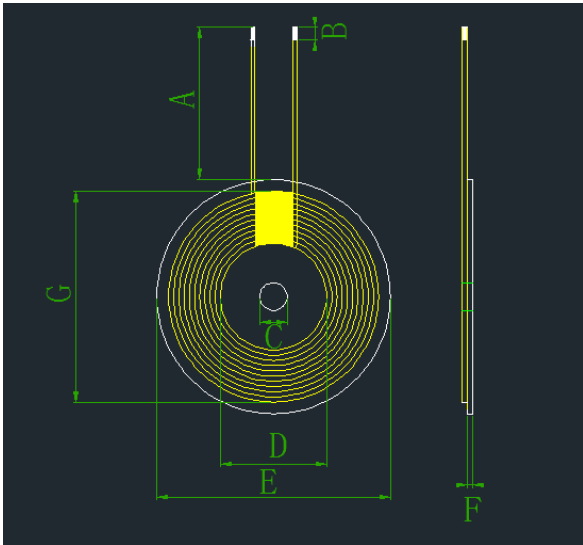

A	28.0±2
B	4±2
C	5.3±0.5
D	20.5±0.5
E	50±0.5
F	0.8±0.2
G	41.0±0.5

50±0.5mm, 5.3mm, 0.8  
±0.2mm

2. SCHEMATIC DIAGRAM:

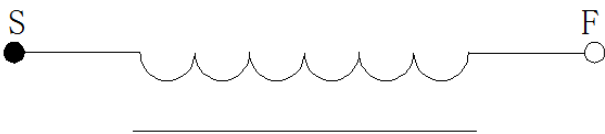

3. Winding Specification:

NO.	TERMINAL	WIRE	Turns	Winding Direction
1	S F	0.07*100P	10Ts	CCW

4. ELECTRICAL CHARACTERISTICS:

TEMPERATURE:25±10℃, RELATIVE HUMIDITY:65±20%

NO.	ITEM	TERMINAL	SPECIFICATIO N	TEST FREQUENCY	TEST EQUIPMENTS
1	IND.	S-F	3.8uH ±20%	100KHz/0.25V	LCZ METER 1062B
2	IND.	S-F	6.5uH ±10%	100KHz/0.25V	LCZ METER 1062B
3	DCR	S-F	≤58mΩ	100KHz/0.25V	LCZ METER 502B
4	Q	S-F	≥50	100KHz/0.25V	LCZ METER 502B

PREPARED BY/DATE

CHECKED BY/DATE

2023/07/01	2023/07/01
------------	------------